34 V Constant-Current LED Driver Controller

NO.EA-365-160510

OUTLINE

The R1580N is a 34-V constant-current LED driver controller. Internally, this device consists of a linear dimming controller using a PWM input signal, a thermal shutdown circuit (TSD), and an undervoltage lockout circuit (UVLO) in addition to the basic constant-current control circuits. A flicker-free wide-dimming constant-current LED driver can be configured by only adding an Nch MOSFET, a current sensing resistor and capacitors to the R1580N. The FET to control current flow is placed externally, so that the R1580N will not give any influence on the current range capable of dealing with. The R1580N is linear dimmable with using a PWM signal on the DIM pin. The R1580N is capable of performing a constant-current control corresponding to the different PWM duty cycles. The R1580N002A is linear dimmable as low as 0.5% PWM duty cycle and the R1580N001A/R1580N003A is linear dimmable as low as 1% PWM duty cycle. Unlike other LED drivers with PWM dimming, the R1580N can provide a smooth flicker-free dimming operation using linear dimming. The R1580N is offered in a small 6-pin SOT-23-6 package.

FEATURES

R1580N001A/ R1580N002A/ R1580N003A

- Input Voltage Range (Max. Rating): 3.6 V to 34.0 V (36.0 V)
- Operating Temperature Range: -40°C to 85°C
- Line Regulation: Typ. 0.01%/V
- Thermal Shutdown Protection
- Linear Dimmable Using a PWM Signal
- Package: SOT-23-6

R1580N001A (Comparator Input, 1.0% PWM Duty)

- Max. SOURCE Pin Voltage Accuracy (100% PWM Duty): Typ. 400 mV \pm 8 mV
- Min. SOURCE Pin Voltage Accuracy (1.0% PWM Duty): Typ. 4 mV \pm 2 mV
- Supply Current: Typ. 320 μ A, Standby Current: Typ. 140 μ A

R1580N002A (Comparator Input, 0.5% PWM Duty)

- Max. SOURCE Pin Voltage Accuracy (100% PWM Duty): Typ. 800 mV \pm 16 mV
- Min. SOURCE Pin Voltage Accuracy (0.5% PWM Duty): Typ. 4 mV \pm 2 mV
- Supply Current: Typ. 320 μ A, Standby Current: Typ. 140 μ A

R1580N003A (Inverter Input, 1.0% PWM Duty)

- Max. SOURCE Pin Voltage Accuracy (100% PWM Duty): Typ. 400 mV \pm 8 mV
- Min. SOURCE Pin Voltage Accuracy (1.0% PWM Duty): Typ. 4 mV \pm 2 mV
- Supply Current: Typ. 320 μ A, Standby Current: Typ. 28 μ A

APPLICATIONS

- General LED Lighting: Down-lights, Base-lights, Ceiling Lights, Exterior Lights
- Industrial LED Lighting: Image Recognition Devices
- Stage Lighting and Signage
- Sports Facility Lighting
- Ultraviolet (UV) and Infrared (IR) Irradiation Devices
- Scanners and Handy Terminals
- Amusement Machines
- Other Electronic Devices

R1580N

NO.EA-365-160510

SELECTION GUIDE

The interface of the DIM pin and the voltage level of the ISET pin are user-selectable options.

Selection Guide

Product Name	Package	Quantity per Reel	Pb Free	Halogen Free
R1580NxxxA-TR-FE	SOT-23-6	3,000 pcs	Yes	Yes

xxx: Specify the interface of the DIM pin and the voltage level of the ISET pin.

001: ISET Pin Voltage = 0.4 V, DIM Pin Interface = Comparator Input,
High Accuracy PWM Signal Threshold Voltage

002: ISET Pin Voltage = 0.8 V, DIM Pin Interface = Comparator Input,
High Accuracy PWM Signal Threshold Voltage

003: ISET Pin Voltage = 0.4 V, DIM Pin Interface = Inverter Input

BLOCK DIAGRAMS

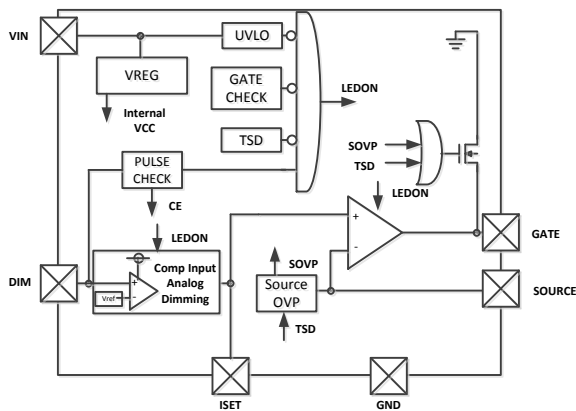

R1580N001A, R1580N002A Block Diagram

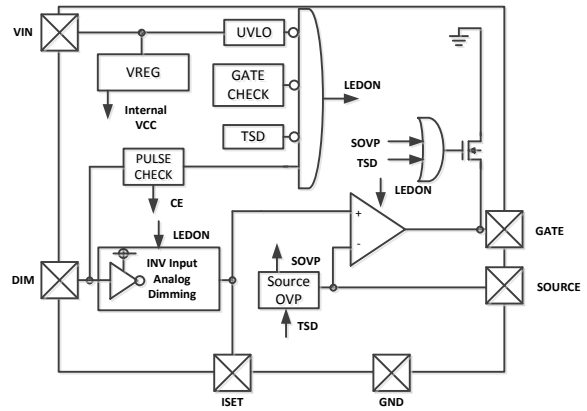

R1580N003A Block Diagram

PIN DESCRIPTIONS

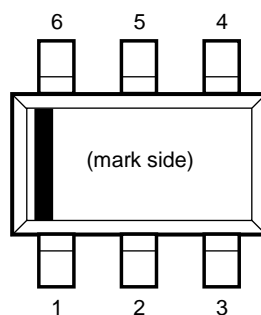

SOT-23-6 Pin Configuration

SOT-23-6 Pin Description

Pin No.	Pin Name	Description
1	ISET	Current Setting Pin
2	SOURCE	Nch MOSFET Source Input Pin
3	GATE	Nch MOSFET Gate Output Pin
4	VIN	Power Supply Voltage Pin
5	GND	Ground Pin
6	DIM	PWM Signal Input Pin

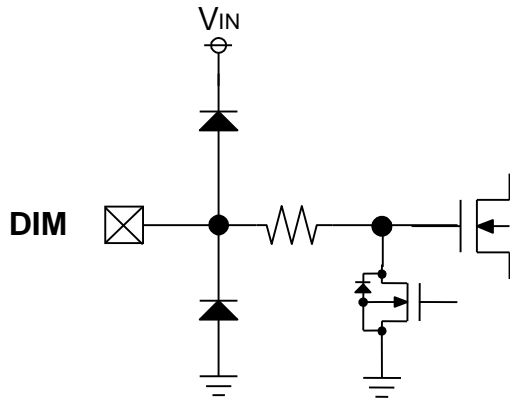
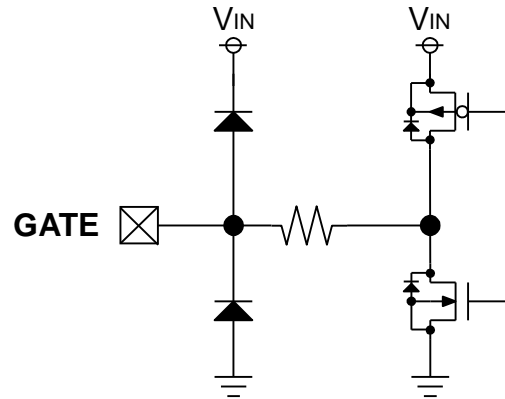
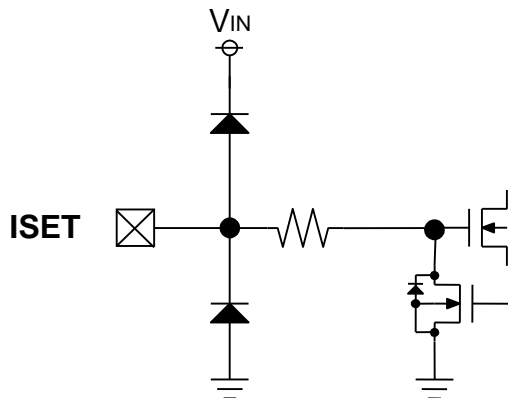
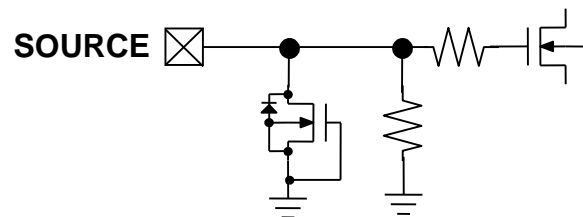
Equivalent Circuits of Individual Pins**Equivalent Circuit for DIM Pin****Equivalent Circuit for GATE Pin****Equivalent Circuit for ISET Pin****Equivalent Circuit for SOURCE Pin**

An ESD diode is connected between the DIM pin and the V_{IN} pin, the GATE pin and the V_{IN} pin, and the ISET pin and the V_{IN} pin. If a voltage is applied to the individual pin while the V_{IN} pin is open, the voltage will flow into the V_{IN} pin via the ESD protection diode and cause an unintended operation of device. To prevent this, apply a voltage to the V_{IN} pin.

ABSOLUTE MAXIMUM RATINGS

Absolute Maximum Ratings

Symbol	Parameter	Rating	Unit
V _{IN}	VIN Pin Voltage	-0.3 to 36	V
V _{DIM}	DIM Pin Voltage	-0.3 to V _{IN} + 0.3	V
V _{ISET}	ISET Pin Voltage	-0.3 to V _{IN} + 0.3	V
V _{SOURCE}	SOURCE Pin Voltage	-0.3 to 6.5	V
V _{GATE}	GATE Pin Voltage	-0.3 to V _{IN} + 0.3	V
I _{DIM}	DIM Pin Current	20	mA
P _D	Power Dissipation (Standard Land Pattern) ⁽¹⁾	420	mW
T _j	Junction Temperature Range	-40 to 125	°C
T _{stg}	Storage Temperature Range	-55 to 125	°C

ABSOLUTE MAXIMUM RATINGS

Electronic and mechanical stress momentarily exceeded absolute maximum ratings may cause the permanent damages and may degrade the life time and safety for both device and system using the device in the field. The functional operation at or over these absolute maximum ratings are not assured.

RECOMMENDED OPERATING CONDITIONS

Recommended Operating Conditions

Symbol	Parameter	Rating	Unit
V _{IN}	Operating Input Voltage	3.6 to 34	V
T _a	Operating Temperature Range	-40 to 85	°C

RECOMMENDED OPERATING CONDITIONS

All of electronic equipment should be designed that the mounted semiconductor devices operate within the recommended operating conditions. The semiconductor devices cannot operate normally over the recommended operating conditions, even if when they are used over such conditions by momentary electronic noise or surge. And the semiconductor devices may receive serious damage when they continue to operate over the recommended operating conditions.

⁽¹⁾ Refer to *POWER DISSIPATION* for detailed information.

R1580N

NO.EA-365-160510

ELECTRICAL CHARACTERISTICS

PWM Frequency = 1 kHz, PWM Duty = 100%, unless otherwise noted.

The specifications surrounded by are guaranteed by design engineering at $-40^{\circ}\text{C} \leq T_a \leq 85^{\circ}\text{C}$.

R1580N Electrical Characteristics

($T_a = 25^{\circ}\text{C}$)

Symbol	Parameter	Test Conditions/ Comments	Min.	Typ.	Max.	Unit
Istandby	Standby Current (001, 002)	$V_{IN} = 34\text{ V}, V_{DIM} = 0\text{ V}$		140	200	μA
	Standby Current (003)	$V_{IN} = 34\text{ V}, V_{DIM} = 0\text{ V}$		28	50	μA
I _{SS}	Supply Current	$V_{IN} = 34\text{ V}, V_{DIM} = 34\text{ V}$		320	500	μA
V _{UVLO1}	UVLO Detector Threshold Voltage	V _{IN} Falling	2.8	3.0		V
V _{UVLO2}		V _{IN} Rising		V _{UVLO1} +0.15	3.3	V
R _{GATEDOWN}	GATE Pin Pull-down Resistance	$V_{DIM} = 0\text{ V}$		20		k Ω
R _{SOURCEDOWN}	SOURCE Pin Pull-down Resistance	$V_{DIM} = 0\text{ V}$		4		k Ω
R _{ISSETDOWN}	ISET Pin Pull-down Resistance	$V_{DIM} = 0\text{ V}$		13		k Ω
t _{LEDONDLY}	LEDON Delay Time	$V_{IN} = 15\text{ V}$	5	20	30	msec
f _{DIMMIN}	Min. PWM Signal Input Frequency	$V_{IN} = 15\text{ V}$			500	Hz
t _{MINON}	Min. PWM Signal ON Time	$V_{IN} = 15\text{ V}$		100		nsec
I _{GATEH}	GATE Pin "High" Output Current	PWM Duty = 100%, $V_{GATE} = 4\text{ V}, V_{SOURCE} = 0\text{ V}$	40	80	160	μA
I _{GATEL}	GATE Pin "Low" Output Current (001, 003)	PWM Duty = 100%, $V_{GATE} = 4\text{ V}, V_{SOURCE} = 0.5\text{ V}$		1		mA
	GATE Pin "Low" Output Current (002)	PWM Duty = 100%, $V_{GATE} = 4\text{ V}, V_{SOURCE} = 0.9\text{ V}$		1		mA
V _{SOURCEMAX}	Max. SOURCE Pin Voltage Accuracy (001, 003)	PWM Duty = 100%, $R_{SET} = \text{Open}$	392	400	408	mV
	Max. SOURCE Pin Voltage Accuracy (002)	PWM Duty = 100%, $R_{SET} = \text{Open}$	784	800	816	mV
V _{SOURCEMIN}	Min. SOURCE Pin Voltage Accuracy (001, 003)	PWM Duty = 1.0%, $R_{SET} = \text{Open}, T_a = 25^{\circ}\text{C}$	2.0	4.0	6.0	mV
		PWM Duty = 1.0%, $R_{SET} = \text{Open}$	1.5	4.0	6.5	mV
	Min. SOURCE Pin Voltage Accuracy (002)	PWM Duty = 0.5%, $R_{SET} = \text{Open}, T_a = 25^{\circ}\text{C}$	2.0	4.0	6.0	mV
		PWM Duty = 0.5%, $R_{SET} = \text{Open}$	1.5	4.0	6.5	mV

All parameters are tested under the pulse load condition ($T_j \approx T_a = 25^{\circ}\text{C}$) except SOURCE Pin Voltage Temperature Coefficient.

ELECTRICAL CHARACTERISTICS (continued)

PWM Frequency = 1 kHz, PWM Duty = 100%, unless otherwise noted.

The specifications surrounded by are guaranteed by design engineering at $-40^{\circ}\text{C} \leq T_a \leq 85^{\circ}\text{C}$.

R1580N Electrical Characteristics

($T_a = 25^{\circ}\text{C}$)

Symbol	Parameter	Test Conditions/ Comments	Min.	Typ.	Max.	Unit
$\Delta V_{\text{SOURCE}} / \Delta T_a$	SOURCE Pin Voltage Temperature Coefficient	$V_{\text{IN}} = 15 \text{ V}$, PWM Duty = 100%		±100		ppm / $^{\circ}\text{C}$
$\Delta V_{\text{SOURCE}} / \Delta V_{\text{IN}}$	SOURCE Pin Voltage Line Regulation	PWM Duty = 100%, $R_{\text{SET}} = \text{Open}$		0.01		%/V
R_{INSET}	ISET Pin Internal Resistance		291	300	309	k Ω
I_{DIM}	DIM Pin Pull-down Current (001, 002)	$V_{\text{DIM}} = 34 \text{ V}$		1.0	2.0	μA
R_{DIM}	DIM Pin Pull-down Resistance (003)	$V_{\text{DIM}} = 2 \text{ V}$	200	600	1200	k Ω
V_{THDIMH}	PWM Signal Threshold Voltage (001, 002)	$V_{\text{IN}} = 15 \text{ V}$, DIM Rising		1.2	1.3	V
V_{THDIML}		$V_{\text{IN}} = 15 \text{ V}$, DIM Falling	1.0	1.1		V
V_{THDIMH}	PWM Signal Threshold Voltage (003)	$V_{\text{IN}} = 15 \text{ V}$, DIM Rising			1.2	V
V_{THDIML}		$V_{\text{IN}} = 15 \text{ V}$, DIM Falling	0.4			V
V_{SOVP1}	SOURCE Pin Overvoltage Protection Threshold Voltage (001, 003)	$V_{\text{IN}} = 15 \text{ V}$, Rising	0.56	0.63	0.70	V
V_{SOVP2}		$V_{\text{IN}} = 15 \text{ V}$, Falling	0.51	0.58	0.65	V
V_{SOVP1}	SOURCE Pin Overvoltage Protection Threshold Voltage (002)	$V_{\text{IN}} = 15 \text{ V}$, Rising	1.23	1.3	1.37	V
V_{SOVP2}		$V_{\text{IN}} = 15 \text{ V}$, Falling	1.13	1.2	1.27	V
T_{TSD}	Thermal Shutdown Threshold Temperature	Ta Rising		160		$^{\circ}\text{C}$
T_{TSR}		Ta Falling		140		$^{\circ}\text{C}$

All parameters are tested under the pulse load condition ($T_j \approx T_a = 25^{\circ}\text{C}$) except SOURCE Pin Voltage Temperature Coefficient.

THEORY OF OPERATION

Under Voltage Lockout (UVLO)

The UVLO turns the output of the GATE pin low which means the Nch MOSFET is turned off, in the event of the input voltage (V_{IN}) dropping below the UVLO threshold voltage, falling (V_{UVLO1}), so that the whole system will go into the reset state.

Short Circuit Detection between the GATE Pin and the DRAIN Pin

The short circuit detection monitors the GATE pin voltage whether it drops close to 1 V at start-up by the connection of a pull-down resistor. If there's an event of short circuit between the DRAIN pin and the SOURCE pin, the GATE pin voltage will not drop close to 1 V due to the continuous output of the DRAIN pin voltage. As a result, the device will not be able to move to the sequence of making the LED current (I_{LED}) flow. Once the short circuit is released, the device will move to the sequence of making a set LED current (I_{LEDSET}) flow.

Overvoltage Protection for Source Pin (Source OVP)

The SOURCE pin voltage (V_{SOURCE}) of the R1580N001A/ R1580N003A is controlled to be less than 0.7 V by the GATE pin of Nch MOSFET, and V_{SOURCE} of the R1580N002A is controlled to be less than 1.4 V. If V_{SOURCE} exceeds the SOURCE pin OVP threshold voltage, rising (V_{SOVP1}), the device assumes that the external voltage is applied, so it moves to the protection sequence. During the protection sequence, the device turns the output of the GATE pin low which means the Nch MOSFET is turned off.

If V_{SOURCE} falls below the SOURCE pin OVP threshold voltage, falling (V_{SOVP2}), the device assumes that the overvoltage conditions is removed and restarts the regulation of Nch MOSFET. In the event of short circuit between the DRAIN pin and the SOURCE pin or the DRAIN pin and GATE pin of Nch MOSFET, V_{SOURCE} rises even if the output of the GATE pin is low. As a result, the current continuously flows into the current sensing resistor (R_{SNS}). If the short circuit current exceeds the rated current of LED, connect a current fuse to the LED array in series.

Thermal Shutdown

The thermal shutdown turns the output of the GATE pin low which means the Nch MOSFET is turned off if the junction temperature exceeds the thermal shutdown threshold temperature, rising (T_{TSD}). Once the junction temperature falls below the thermal shutdown threshold temperature, falling (T_{TSD}), the device goes into the reset state and restarts the regulation of Nch MOSFET.

Timing Chart of PWM Signal

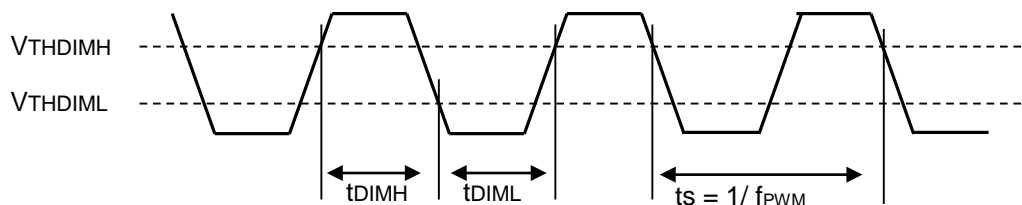

Timing Chart of PWM Signal

The R1580N recognizes that a high signal is sent to the DIM pin during the period of time which starts when the DIM pin voltage (V_{DIM}) exceeds the PWM signal threshold voltage, rising (V_{THDIMH}), and ends when V_{DIM} falls below the PWM signal threshold voltage, falling (V_{THDIML}). On the contrary, the R1580N recognizes that a low signal is sent to the DIM pin during the period of time which starts when V_{DIM} falls below V_{THDIML} , and ends when V_{DIM} exceeds V_{THDIMH} .

When V_{DIM} exceeds V_{THDIMH} , the R1580N starts the operation. After the device start-up, the DIM pin pulse judging circuit starts the operation. The LEDON signal becomes high if the DIM pin pulse is sent for more than the LEDON delay time ($t_{LEDONDLY} = \text{Typ. } 20 \text{ msec}$) with one of the following conditions:

1. $t_{DIML} \leq 10 \mu\text{sec}$ & $t_{DIMH} \geq t_{MINON}$ when 100% LED dimming control, $V_{DIM} = \text{fixed at high}$.
2. PWM Frequency (f_{PWM}) $\geq 500 \text{ Hz}$ & $t_{DIMH} \geq t_{MINON}$

When the LEDON signal becomes high, the ISET pin voltage (V_{ISET}) gradually goes up along with the SOURCE pin voltage (V_{SOURCE}). After the PWM signal response time (t_{DIMDLY}), the LED current (I_{LED}) becomes $\pm 5\%$ of a set LED current (I_{LEDSET}). The R1580N goes into standby state and turns the LEDs off by inputting a low signal to the DIM pin.

R1580N

NO.EA-365-160510

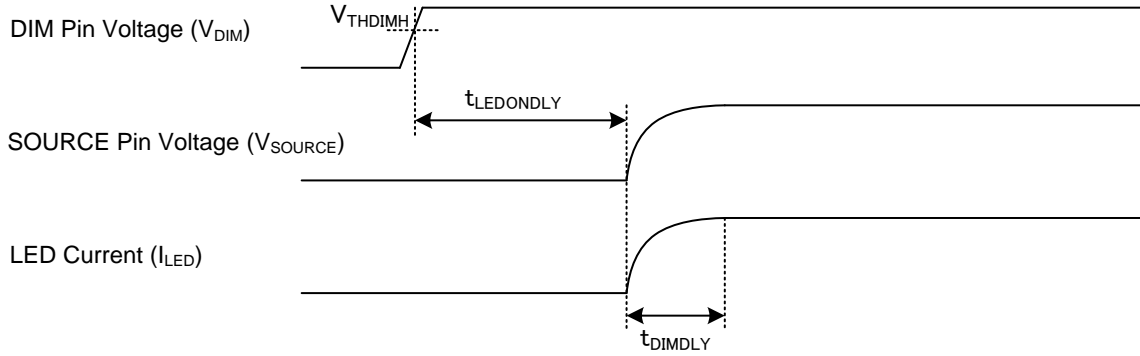
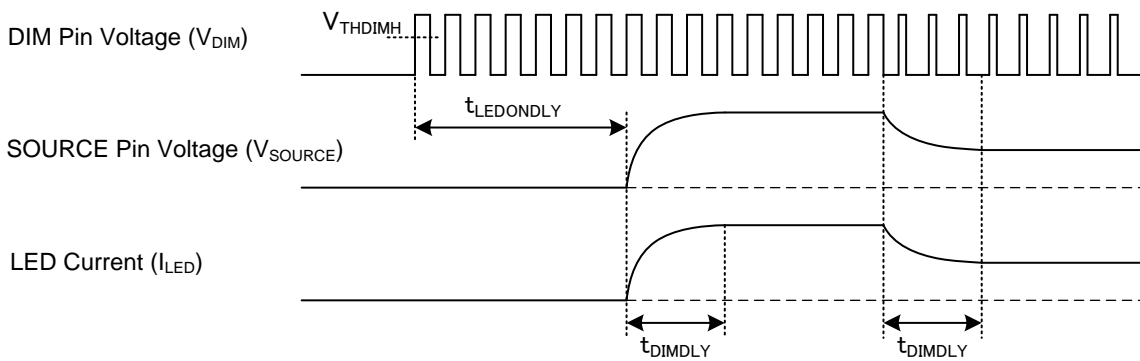
1. $V_{DIM} = H$, PWM Duty $\approx 100\%$, Refer to *Timing Chart of PWM Signal*2. $V_{DIM} = \text{Pulse}$, PWM Frequency ($f_{PWM} \geq 500 \text{ Hz}$) & $t_{DIMH} \geq t_{MINON}$ **PWM Signal Response Time (t_{DIMDLY})**

The PWM signal response time (t_{DIMDLY}) can be calculated as follows using the LED current setting resistor (R_{SET}) and the capacitor (C_{SET}).

Rset \neq OPEN:

$$2.5 \times (C_{SET} \times (R_{SET} \times R_{INSET}) / (R_{SET} + R_{INSET})) \leq t_{DIMDLY} [\text{sec}] \leq 3.5 \times (C_{SET} \times (R_{SET} \times R_{INSET}) / (R_{SET} + R_{INSET}))$$

Rset = OPEN:

$$2.5 \times C_{SET} \times R_{INSET} \leq t_{DIMDLY} [\text{sec}] \leq 3.5 \times C_{SET} \times R_{INSET}$$

APPLICATION INFORMATION

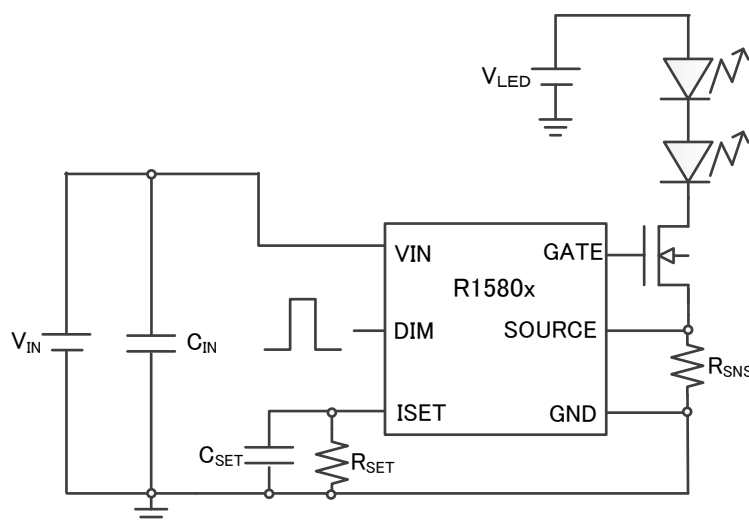

R1580NxxxA Typical Application Circuit

Recommended Components

Symbol	Description
C _{IN}	Bypass Capacitor, 0.1 μF or more, 50 V Rated Voltage, C1608JB1H104K080AA, TDK
C _{SET}	Capacitor, 0.01 μF or more ⁽¹⁾ , 6.3 V Rate Voltage
R _{SET}	LED Current Setting Resistor
R _{SNS}	Current Sensing Resistor

⁽¹⁾ The recommended value for the capacitor can be changed depending on the PWM frequency.

R1580N

NO.EA-365-160510

LED Current Setting at 100% PWM Duty Cycle

The LED current (I_{LED}) at PWM duty = 100 % can be programmed by placing a current setting resistor (R_{SET}) between the ISET pin and GND, and a current sensing resistor (R_{SNS}) between the SOURCE pin and GND. When using R_{SET} , note that the variation in the ISET internal resistance (R_{INSET}) influences the LED current accuracy. The set LED current (I_{LEDSET}) can be calculated as follows:

R1580N001A/ R1580N003A

Rset \neq OPEN:

$$I_{LEDSET} = 0.4 / R_{SNS} \times R_{SET} / (R_{INSET} + R_{SET})$$

Rset = OPEN:

$$I_{LEDSET} = 0.4 / R_{SNS}$$

R1580N002A

Rset \neq OPEN:

$$I_{LEDSET} = 0.8 / R_{SNS} \times R_{SET} / (R_{INSET} + R_{SET})$$

Rset = OPEN:

$$I_{LEDSET} = 0.8 / R_{SNS}$$

For example, with the R1580N001A, if R_{SET} is open and $R_{SNS} = 1 \Omega$, the R_{SNS} current at PWM Duty = 100% will be set to 400 mA. When using R_{SET} , it should be 100 k Ω or more.

LED Dimming Control

I_{LED} can be controlled using a PWM signal on the DIM pin. I_{LED} can be calculated by using a duty cycle of PWM signal in high state (Hduty) as follows:

$$I_{LED} = Hduty \times I_{LEDSET}$$

Hduty should be determined so as to achieve that the pulse width of PWM frequency (f_{PWM}) in high state is more than the minimum on time of PWM input (t_{MINON}).

$$Hduty / f_{PWM} \geq t_{MINON}$$

PWM Frequency

The PWM frequency (f_{PWM}) on the DIM pin should be set in the range of 500 Hz to 100 kHz. Placing a capacitor (C_{SET}) and a current setting resistor (R_{SET}) between the ISET pin and GND can attenuate the PWM frequency components in the LED current (I_{LED}). The optimum time constant (τ) varies with f_{PWM} . The optimum time constant (τ) can be calculated as follows using C_{SET} and R_{SET} :

$$\tau RC [\text{sec}] = (C_{SET} \times (R_{SET} \times R_{INSET}) / (R_{SET} + R_{INSET})) \geq 30 [\text{sec}] / f_{PWM} [\text{Hz}]$$

$$C_{SET} [\mu\text{F}] \geq 30 [\text{sec}] / f_{PWM} [\text{Hz}] \times 10^6 \times (R_{SET} [\Omega] + R_{INSET}) / (R_{SET} [\Omega] \times R_{INSET}) \geq 10 [\text{nF}]$$

For example, if R_{SET} is open and $f_{PWM} = 1$ kHz, C_{SET} can be calculated as follows:

$$C_{SET} [\mu\text{F}] \geq 30 [\text{sec}] / 1000 \times 10^6 \times 1 / 300 \text{ k} = 0.1 [\mu\text{F}] \geq 10 [\text{nF}]$$

Thus, C_{SET} should be set to 0.1 μF or more. It is important to place C_{SET} between the ISET pin and GND to attenuate f_{PWM} .

As mentioned in *LED Dimming Control*, Hduty should be determined on the condition that the pulse width of PWM frequency (f_{PWM}) in high state is more than the min. PWM signal on time (t_{MINON}). It is necessary that f_{PWM} be increased so that Hduty of the required brightness becomes more than t_{MINON} . Also, it is necessary that f_{PWM} be decreased if the high-accuracy dimming in low brightness is required.

Capacitor Selection

A 0.1- μF or more bypass capacitor (C_{IN}) should be placed between the VIN pin and GND with shortest-distance wiring.

DIM Pin Voltage

The ESD protection diode for the VIN pin is connected to the DIM pin. If the DIM pin voltage (V_{DIM}) becomes higher than the VIN voltage (V_{IN}), a large current will flow from the DIM pin to the VIN pin. To prevent this, it is recommended that a resistor be connected to the DIM pin. The resistor connected to the DIM pin filters the voltage waveform of the DIM pin and creates the rounding waveform. As a result, I_{LED} will be deviated from the calculated value. If the deviation of I_{LED} is not in an allowable range, remove the resistor for the DIM pin and make the input voltage lower than V_{IN} , or place a 100- Ω or more resistor (R_{IN}) between the VIN pin and the primary power source and suppress the current flowing into the DIM pin lower than 20 mA.

R1580N

NO.EA-365-160510

Rated Voltage for Nch MOSFET

Select an Nch MOSFET with low drain cut-off current to prevent the LEDs to emit light during standby state. The GATE pin voltage (V_{GATE}) may go up to the maximum VIN pin voltage (V_{IN}) level. To prevent the destruction of Nch MOSFET due to V_{IN} becoming higher than the VGS absolute maximum rating of Nch MOSFET, connect a zener diode between the GATE pin and GND.

In the event of the LED current (I_{LED}) becoming 0 mA while the LED anode voltage is becoming maximum, the DRAIN pin voltage of Nch MOSFET instantaneously goes up close to the LED anode voltage. To prevent the destruction of Nch MOSFET due to the LED anode voltage becoming higher than the VDS absolute maximum rating of Nch MOSFET, connect a zener diode between the DRAIN pin of Nch MOSFET and GND. Select an Nch MOSFET that can operate within the rated voltage.

Thermal Design for Nch MOSFET

The heat loss can be influenced by a power loss associated with the potential difference between the DRAIN pin and the SOURCE pin (V_{DS}) and I_{LED} . The power loss in Nch MOSFET (P_{FET}) can be calculated as follows:

$$P_{FET} [W] = V_{DS} \times I_{LED}$$

Select an Nch MOSFET that can operate within the rated power. It is recommended that an Nch MOSFET satisfying the following conditions be selected:

$$T_j_FET \geq \theta_{ja_FET} \times P_{FET} + T_a$$

Minimum DRAIN Pin Voltage for Nch MOSFET

The minimum DRAIN pin voltage of Nch MOSFET (V_{DRAIN}) can be calculated as follows using the On resistance of Nch MOSFET (R_{ON}) and the maximum SOURCE pin voltage (V_{SMAX}):

$$V_{DRAIN} [V] \geq R_{ON} \times I_{LED} + V_{SMAX}$$

$$V_{SMAX} = V_{SOURCEMAX} \times R_{SET} / (R_{SET} + R_{INSET})$$

Current Sense Resistor Selection

A current sensing resistor (R_{SNS}) should be placed between the SOURCE pin of Nch MOSFET and GND of the device with shortest-distance wiring. To reduce the influence of the wiring resistance on the accuracy of LED current, make the wiring as wide as possible.

Choose an appropriate value for R_{SNS} that best fits the application. The power loss generated by R_{SNS} (P_{SNS}) can be calculated as follows. To suppress P_{SNS} , place a current setting resistor (R_{SET}) which reduces the maximum SOURCE pin voltage.

R1580N001A/ R1580N003A

Rset ≠ OPEN:

$$P_{SNS} [W] = \{0.4 \times R_{SET} / (R_{SET} + R_{INSET})\}^2 / R_{SNS}$$

Rset = OPEN:

$$P_{SNS} [W] = (0.4)^2 / R_{SNS}$$

R1580N002A

Rset ≠ OPEN:

$$P_{SNS} [W] = \{0.8 \times R_{SET} / (R_{SET} + R_{INSET})\}^2 / R_{SNS}$$

Rset = OPEN:

$$P_{SNS} [W] = (0.8)^2 / R_{SNS}$$

TYPICAL PERFORMANCE CHARACTERISTICS

Note: Typical Characteristics are intended to be used as reference data; they are not guaranteed.

Standby Current vs. Ambient Temp.

R1580N001A, 003A, $V_{IN} = 34\text{ V}$, $V_{DIM} = 0\text{ V}$

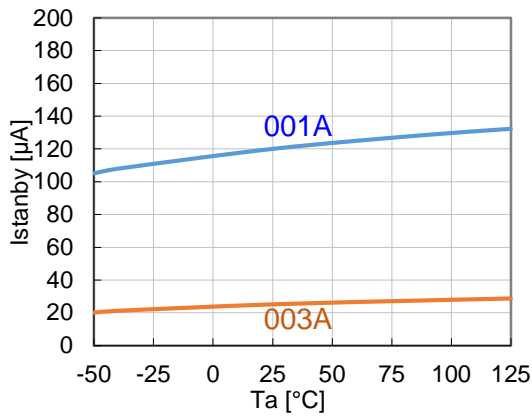

Supply Current vs. Ambient Temp.

R1580N001A, $V_{IN} = 34\text{ V}$, $V_{DIM} = 34\text{ V}$

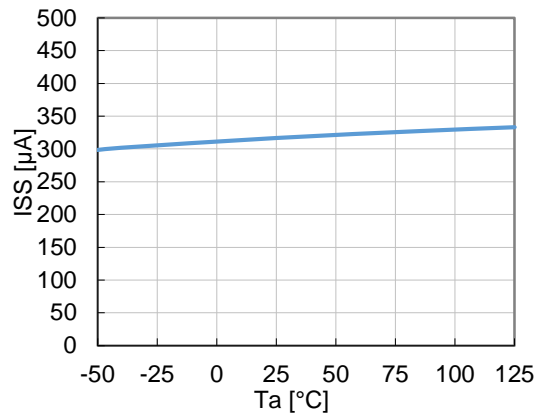

Max. SOURCE Pin Voltage vs. Ambient Temp.

R1580N001A, PWM Duty = 100%, $R_{SET} = \text{OPEN}$

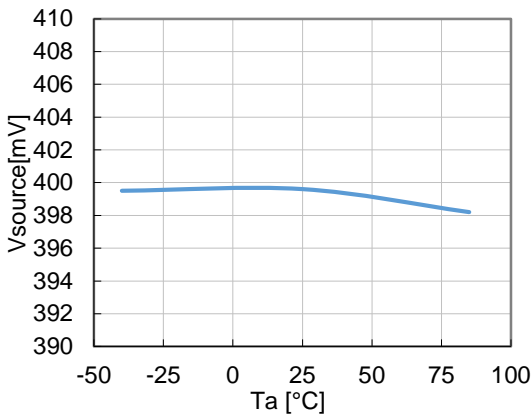

Max. SOURCE Pin Voltage vs. Ambient Temp.

R1580N002A, PWM Duty = 100%, $R_{SET} = \text{OPEN}$

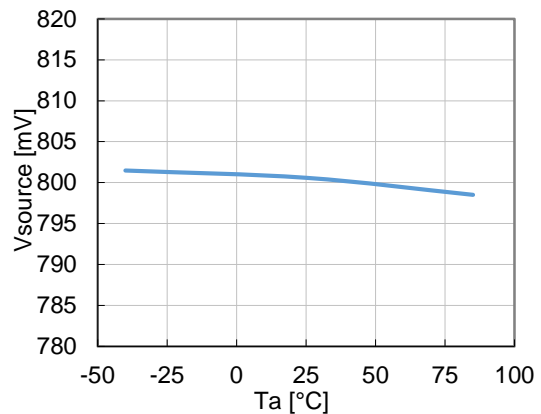

Min. SOURCE Pin Voltage vs. Ambient Temp.

R1580N001A, PWM Duty = 1.0%, $R_{SET} = \text{OPEN}$

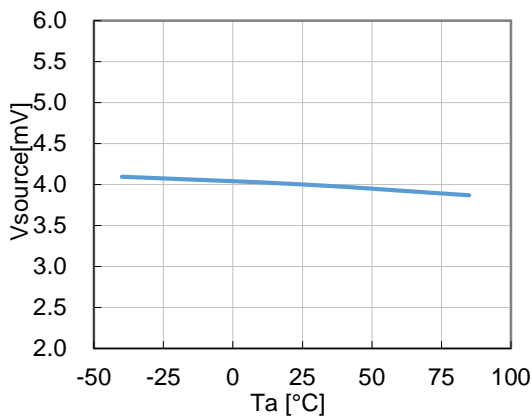

Min. SOURCE Pin Voltage vs. Ambient Temp.

R1580N002A, PWM Duty = 0.5%, $R_{SET} = \text{OPEN}$

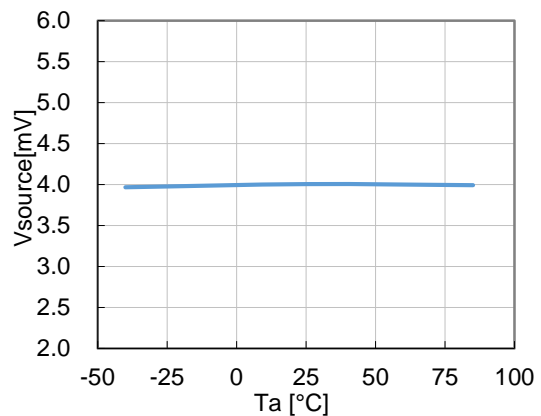

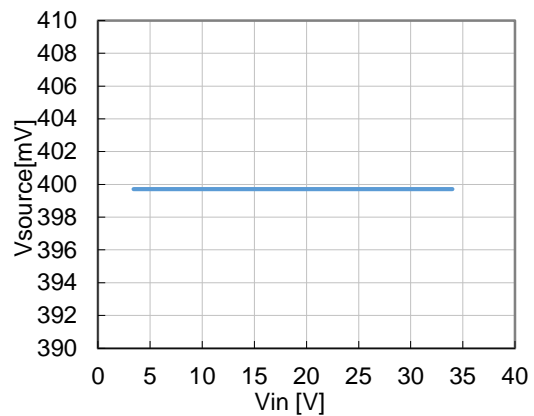
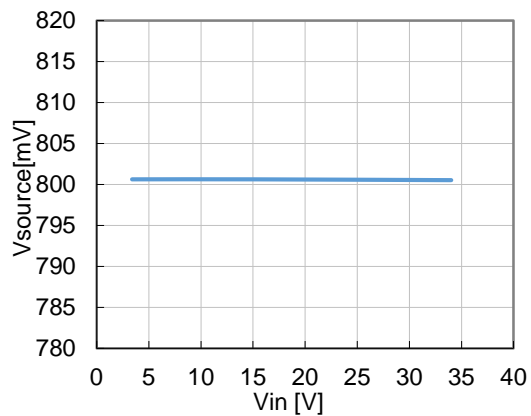
Max. SOURCE Pin Voltage vs. Input VoltageR1580N001A, PWM Duty = 100%, R_{SET} = OPEN**Max. SOURCE Pin Voltage vs. Input Voltage**R1580N002A, PWM Duty = 100%, R_{SET} = OPEN

The power dissipation of the package is dependent on PCB material, layout, and environmental conditions. The following conditions are used in this measurement.

Measurement Conditions

	Standard Test Land Pattern
Environment	Mounting on Board (Wind Velocity = 0 m/s)
Board Material	Glass Cloth Epoxy Plastic (Double-Sided Board)
Board Dimensions	40 mm x 40 mm x 1.6 mm
Copper Ratio	Top Side: Approx. 50% Bottom Side: Approx. 50%
Through-holes	φ 0.5 mm x 44 pcs

Measurement Result

(Ta = 25°C, Tjmax = 125°C)

	JEDEC STD.51-7 Test Land Pattern	Free Air
Power Dissipation	420 mW	250 mW
Thermal Resistance	$\theta_{ja} = (125 - 25^\circ\text{C}) / 0.42 \text{ W} = 238^\circ\text{C/W}$	400°C/W

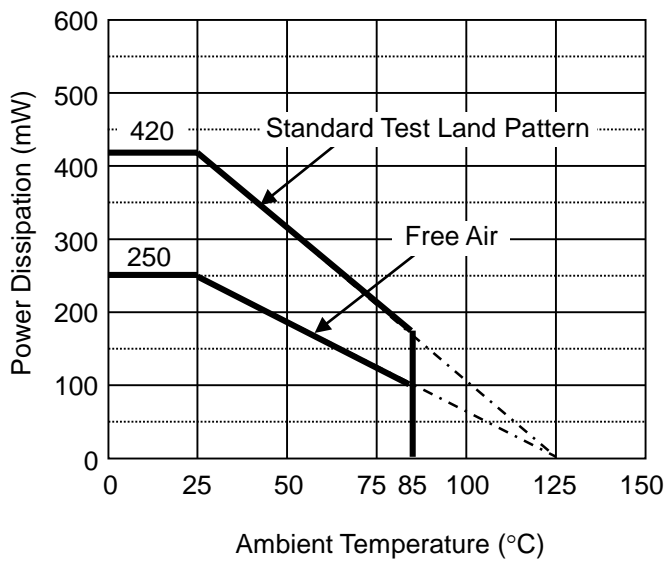

Power Dissipation vs. Ambient Temperature

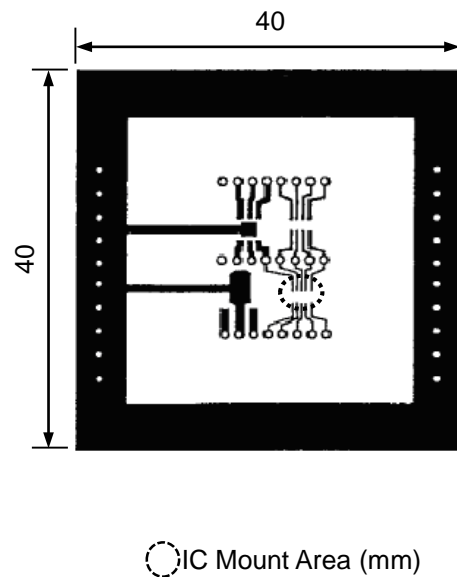

Measurement Board Pattern

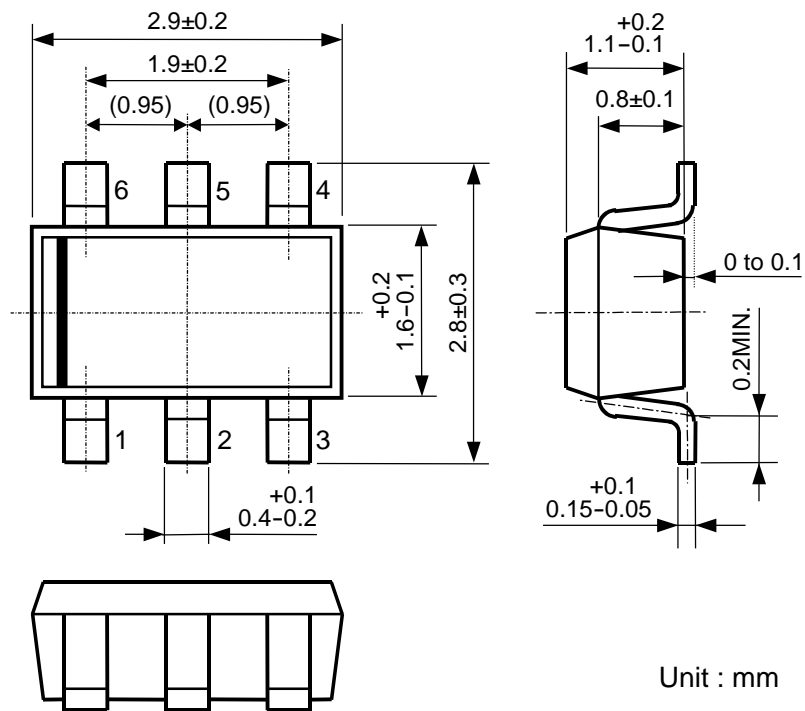

SOT-23-6 Package Dimensions



1. The products and the product specifications described in this document are subject to change or discontinuation of production without notice for reasons such as improvement. Therefore, before deciding to use the products, please refer to Ricoh sales representatives for the latest information thereon.
2. The materials in this document may not be copied or otherwise reproduced in whole or in part without prior written consent of Ricoh.
3. Please be sure to take any necessary formalities under relevant laws or regulations before exporting or otherwise taking out of your country the products or the technical information described herein.
4. The technical information described in this document shows typical characteristics of and example application circuits for the products. The release of such information is not to be construed as a warranty of or a grant of license under Ricoh's or any third party's intellectual property rights or any other rights.
5. The products listed in this document are intended and designed for use as general electronic components in standard applications (office equipment, telecommunication equipment, measuring instruments, consumer electronic products, amusement equipment etc.). Those customers intending to use a product in an application requiring extreme quality and reliability, for example, in a highly specific application where the failure or misoperation of the product could result in human injury or death (aircraft, spacevehicle, nuclear reactor control system, traffic control system, automotive and transportation equipment, combustion equipment, safety devices, life support system etc.) should first contact us.
6. We are making our continuous effort to improve the quality and reliability of our products, but semiconductor products are likely to fail with certain probability. In order to prevent any injury to persons or damages to property resulting from such failure, customers should be careful enough to incorporate safety measures in their design, such as redundancy feature, fire containment feature and fail-safe feature. We do not assume any liability or responsibility for any loss or damage arising from misuse or inappropriate use of the products.
7. Anti-radiation design is not implemented in the products described in this document.
8. Please contact Ricoh sales representatives should you have any questions or comments concerning the products or the technical information.



Ricoh is committed to reducing the environmental loading materials in electrical devices with a view to contributing to the protection of human health and the environment.

Ricoh has been providing RoHS compliant products since April 1, 2006 and Halogen-free products since April 1, 2012.

RICOH RICOH ELECTRONIC DEVICES CO., LTD.

<http://www.e-devices.ricoh.co.jp/en/>

Sales & Support Offices

RICOH ELECTRONIC DEVICES CO., LTD.

Higashi-Shinagawa Office (International Sales)
3-32-3, Higashi-Shinagawa, Shinagawa-ku, Tokyo 140-8655, Japan
Phone: +81-3-5479-2857 Fax: +81-3-5479-0502

RICOH EUROPE (NETHERLANDS) B.V.

Semiconductor Support Centre
Prof. W.H. Keesomlaan 1, 1183 DJ Amstelveen, The Netherlands
Phone: +31-20-5474-309

RICOH INTERNATIONAL B.V. - German Branch

Semiconductor Sales and Support Centre
Oberrather Strasse 6, 40472 Düsseldorf, Germany
Phone: +49-211-6546-0

RICOH ELECTRONIC DEVICES KOREA CO., LTD.

3F, Haesung Bldg, 504, Teheran-ro, Gangnam-gu, Seoul, 135-725, Korea
Phone: +82-2-2135-5700 Fax: +82-2-2051-5713

RICOH ELECTRONIC DEVICES SHANGHAI CO., LTD.

Room 403, No.2 Building, No.690 Bibo Road, Pu Dong New District, Shanghai 201203, People's Republic of China
Phone: +86-21-5027-3200 Fax: +86-21-5027-3299

RICOH ELECTRONIC DEVICES CO., LTD.

Taipei office
Room 109, 10F-1, No.51, Hengyang Rd., Taipei City, Taiwan (R.O.C.)
Phone: +886-2-2313-1621/1622 Fax: +886-2-2313-1623

Mouser Electronics

Authorized Distributor

Click to View Pricing, Inventory, Delivery & Lifecycle Information:

[Ricoh Electronics:](#)

[R1580N001A-TR-FE](#) [R1580N002A-TR-FE](#) [R1580N003A-TR-FE](#)

Компания «Life Electronics» занимается поставками электронных компонентов импортного и отечественного производства от производителей и со складов крупных дистрибьюторов Европы, Америки и Азии.

С конца 2013 года компания активно расширяет линейку поставок компонентов по направлению коаксиальный кабель, кварцевые генераторы и конденсаторы (керамические, пленочные, электролитические), за счёт заключения дистрибьюторских договоров

Мы предлагаем:

- Конкурентоспособные цены и скидки постоянным клиентам.
- Специальные условия для постоянных клиентов.
- Подбор аналогов.
- Поставку компонентов в любых объемах, удовлетворяющих вашим потребностям.
- Приемлемые сроки поставки, возможна ускоренная поставка.
- Доставку товара в любую точку России и стран СНГ.
- Комплексную поставку.
- Работу по проектам и поставку образцов.
- Формирование склада под заказчика.
- Сертификаты соответствия на поставляемую продукцию (по желанию клиента).
- Тестирование поставляемой продукции.
- Поставку компонентов, требующих военную и космическую приемку.
- Входной контроль качества.
- Наличие сертификата ISO.

В составе нашей компании организован Конструкторский отдел, призванный помогать разработчикам, и инженерам.

Конструкторский отдел помогает осуществить:

- Регистрацию проекта у производителя компонентов.
- Техническую поддержку проекта.
- Защиту от снятия компонента с производства.
- Оценку стоимости проекта по компонентам.
- Изготовление тестовой платы монтаж и пусконаладочные работы.



Тел: +7 (812) 336 43 04 (многоканальный)

Email: org@lifeelectronics.ru