

EPCOS Sample Kit 2012

SMD NTC Thermistors

for LED Applications

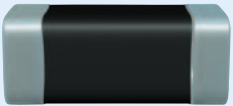

Why thermal sensing?

Today's LED system designers face the challenge of reducing costs whilst satisfying the increasing demands for high lumen efficiency and long lifetime requirements.

The efficiency of LEDs depends very much on the LED junction temperature. Temperature extremes must be avoided, as these lead to faster power degradation, flux reduction, color shift, shortened life time, and even fatal damage to the LED. For maximum efficiency, the LED temperature must be controlled at its specific optimum. The LED temperature is finally an essential indicator of lumen efficiency and the thermal sensor is a key component in the control circuit.

Benefits of thermal sensing with SMD NTC thermistors

SMD NTC thermistors can be used as an integral part of the LED module and can easily be integrated in the assembly process. Small size, good thermal contact to the PCB and negligible self warming make SMD NTC thermistors very sensitive and accurate sensors.

If an SMD NTC is integrated into an LED module, any deviation from the optimum operating temperature of the LED will cause a significant resistance change of the NTC. This will change the current flow through the SMD NTC thermistor and hence change the voltage drop across it. This change can be read by the comparator of the LED driver to adjust the LED driving current which will reduce the power dissipation in the LED increasing its' life-time.

Features

- Highly accurate temperature sensing with low resistance tolerance down to $\pm 1\%$
- High temperature capability up to $+125\text{ }^{\circ}\text{C}$ standard and $+150\text{ }^{\circ}\text{C}$ automotive
- Excellent long-term aging stability in high-temperature environments
- Nickel barrier termination and lead-free solderability
- Automotive product range AEC-Q200 qualified
- Resistance values $10\text{ k}\Omega$ up to $470\text{ k}\Omega$
- Small EIA case sizes 0402 and 0603
- PSpice library available



Important information: Some parts of this publication contain statements about the suitability of our products for certain areas of application. These statements are based on our knowledge of typical requirements that are often placed on our products. We expressly point out that these statements cannot be regarded as binding statements about the suitability of our products for a particular customer application. It is incumbent on the customer to check and decide whether a product is suitable for use in a particular application. This publication is only a brief product survey which may be changed from time to time. Our products are described in detail in our data sheets. The *Important notes* (www.epcos.com/ImportantNotes) and the product-specific *Cautions and warnings* must be observed. All relevant information is available through our sales offices.

Components



Automotive LED illumination (T_{op} -40 ... +150 °C)

B57232 V5103F360	B57251 V5103J060	B57332 V5103F360	B57332 V5103J360	B57352 V5103J060	B57352 V5223J060	B57352 V5473J060	B57352 V5104F360	B57352 V5104J360
---------------------	---------------------	---------------------	---------------------	---------------------	---------------------	---------------------	---------------------	---------------------



General LED illumination (T_{op} -40 ... +125 °C)

B57230 V2103F260	B57261 V2223J060	B57221 V2473J060	B57330 V2103F260	B57321 V2103J60	B57371 V2223J60	B57371 V2473J60	B57374 V2104F60	B57371 V2474J60
---------------------	---------------------	---------------------	---------------------	--------------------	--------------------	--------------------	--------------------	--------------------

Electrical specifications and ordering codes

Temperature range (min/max) [°C]	R ₂₅ [kΩ]	ΔR _R %	B _{25/50} [K]	B _{25/85} [K]	B _{25/100} [K]	Ordering code
EIA case size 0402 – automotive LED illumination						
-40 ... + 150	10	±1	3380	3435	3455 ±1%	B57232V5103F360
-40 ... + 150	10	±5	3380	3435	3455 ±1%	B57232V5103J360
-40 ... + 150	10	±5	3940	3980	4000 ±3%	B57251V5103J060
EIA case size 0603 – automotive LED illumination						
-40 ... + 150	10	±1	3380	3435	3455 ±1%	B57332V5103F360
-40 ... + 150	10	±5	3380	3435	3455 ±1%	B57332V5103J360
-40 ... + 150	10	±3	4386	4455	4480 ±3%	B57352V5103H060
-40 ... + 150	10	±5	4386	4455	4480 ±3%	B57352V5103J060
-40 ... + 150	22	±3	4386	4455	4480 ±3%	B57352V5223H060
-40 ... + 150	22	±5	4386	4455	4480 ±3%	B57352V5223J060
-40 ... + 150	47	±3	4386	4455	4480 ±3%	B57352V5473H060
-40 ... + 150	47	±5	4386	4455	4480 ±3%	B57352V5473J060
-40 ... + 150	100	±1	4386	4455	4480 ±1%	B57352V5104F360
-40 ... + 150	100	±5	4386	4455	4480 ±1%	B57352V5104J360
EIA case size 0402 – general LED illumination						
-40 ... + 125	10	±1	3380	3435	3455 ±1%	B57230V2103F260
-40 ... + 125	10	±5	3380	3435	3455 ±1%	B57230V2103J260
-40 ... + 125	10	±5	3940	3980	4000 ±3%	B57221V2103J060
-40 ... + 125	22	±5	4473	4548	4575 ±3%	B57261V2223J060
-40 ... + 125	47	±5	3940	3980	4000 ±3%	B57221V2473J060
EIA case size 0603 – general LED illumination						
-40 ... + 125	10	±1	3380	3435	3455 ±1%	B57330V2103F260
-40 ... + 125	10	±5	3380	3435	3455 ±1%	B57330V2103J260
-40 ... + 125	10	±3	3940	3980	4000 ±3%	B57321V2103H060
-40 ... + 125	10	±5	3940	3980	4000 ±3%	B57321V2103J060
-40 ... + 125	22	±3	4386	4455	4480 ±3%	B57371V2223H060
-40 ... + 125	22	±5	4386	4455	4480 ±3%	B57371V2223J060
-40 ... + 125	47	±3	4386	4455	4480 ±3%	B57371V2473H060
-40 ... + 125	47	±5	4386	4455	4480 ±3%	B57371V2473J060
-40 ... + 125	100	±1	4386	4455	4480 ±1%	B57374V2104F060
-40 ... + 125	100	±5	4386	4455	4480 ±1%	B57374V2104J060
-40 ... + 125	470	±3	4386	4455	4480 ±3%	B57371V2474H060
-40 ... + 125	470	±5	4386	4455	4480 ±3%	B57371V2474J060

The table is a selection of recommended types.

Special tolerances at selected working temperature can be offered upon request.

See enclosed CD-ROM for data sheets and further details.

Application examples for SMD NTC thermistors

Characteristics

R (T) characteristics

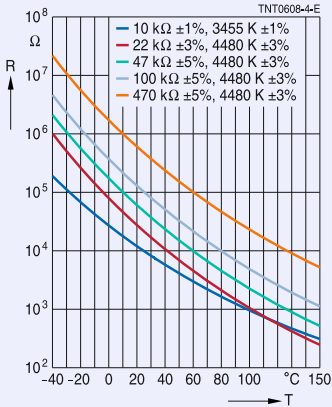

Temperature sensing accuracy

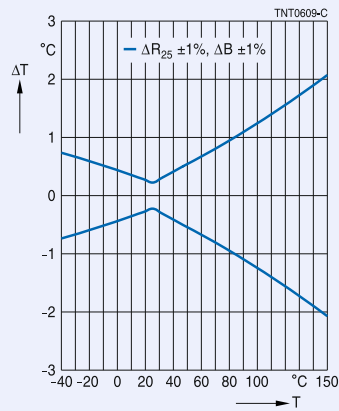

A web-based R/T curve calculation tool is available at <http://www.epcos.com/designtools/ntc/index.html>

Application examples

Simplified circuit example: LED module

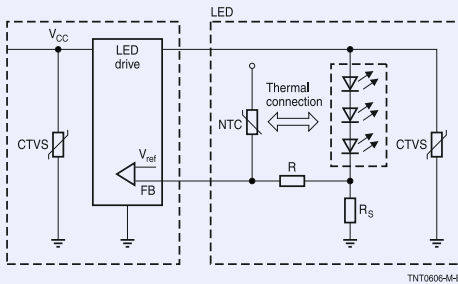

- LED modules for indoor and outdoor illumination
- LED retrofit bulbs and tubes
- LED for consumer and entertainment applications
- LED automotive lighting
- LED industrial applications

Simplified circuit example: RGB backlight

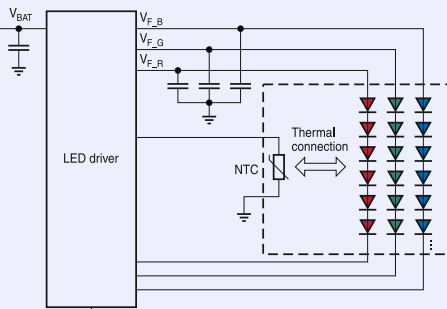

CTVS is a ceramic transient voltage suppressor for the ESD protection of LEDs. More information about CTVS for LED applications is available upon request.

Компания «Life Electronics» занимается поставками электронных компонентов импортного и отечественного производства от производителей и со складов крупных дистрибьюторов Европы, Америки и Азии.

С конца 2013 года компания активно расширяет линейку поставок компонентов по направлению коаксиальный кабель, кварцевые генераторы и конденсаторы (керамические, пленочные, электролитические), за счёт заключения дистрибьюторских договоров

Мы предлагаем:

- Конкуренспособные цены и скидки постоянным клиентам.
- Специальные условия для постоянных клиентов.
- Подбор аналогов.
- Поставку компонентов в любых объемах, удовлетворяющих вашим потребностям.
- Приемлемые сроки поставки, возможна ускоренная поставка.
- Доставку товара в любую точку России и стран СНГ.
- Комплексную поставку.
- Работу по проектам и поставку образцов.
- Формирование склада под заказчика.
- Сертификаты соответствия на поставляемую продукцию (по желанию клиента).
- Тестирование поставляемой продукции.
- Поставку компонентов, требующих военную и космическую приемку.
- Входной контроль качества.
- Наличие сертификата ISO.

В составе нашей компании организован Конструкторский отдел, призванный помогать разработчикам, и инженерам.

Конструкторский отдел помогает осуществить:

- Регистрацию проекта у производителя компонентов.
- Техническую поддержку проекта.
- Защиту от снятия компонента с производства.
- Оценку стоимости проекта по компонентам.
- Изготовление тестовой платы монтаж и пусконаладочные работы.



Тел: +7 (812) 336 43 04 (многоканальный)

Email: org@lifeelectronics.ru