

# PLC-OS.../SEN

## PLC INTERFACE With Solid-State Relay, Sensor Version

### INTERFACE

Data Sheet  
103152\_en\_01

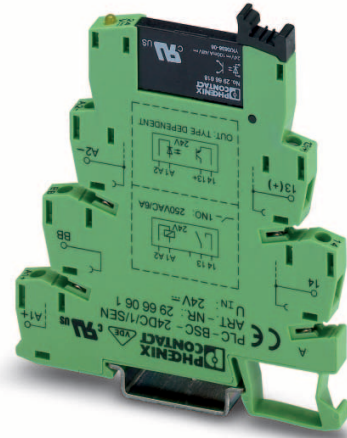

© PHOENIX CONTACT - 03/2008

## 1 Description

In applications as the interface between the PLC and sensors (e.g., proximity switches, limit switches or auxiliary contacts), as a rule only one N/O contact is required. In this case, the **PLC-OS.../SEN** input module can be used, which is specially optimized for these applications and consists of a 6.2 mm basic terminal block and plug-in miniature solid-state relay with screw or spring-cage connection.

### 1.1 No Need for Power Terminal Blocks

Unlike conventional input relays, all sensor connections, including the supply voltage for the sensors and switches, are connected directly to the PLC INTERFACE module. The PLC-OS.../SEN can thus be used directly as a terminal strip with integrated interface function for the incoming sensor cables, without the need for additional modular terminal blocks (see also INTERFACE catalog).

- Elimination of the need for modular terminal blocks for the sensor/switch supply, signal, and sensor ground
- Space savings of around 80%
- Time saving of around 60%
- Reduction in wiring due to plug-in bridges

### 1.2 Optimum Use of Plug-In Bridges

The PLC INTERFACE module achieves maximum efficiency with the user-friendly FBST plug-in bridge system. The PLC-OS.../SEN makes effective use of the bridging options for the power supply for sensors/switches, for the supply/sensor ground at the A2 connection, and for the common supply potential of the PLC at connection 13. Especially effective here are the 500 mm long color-insulated continuous plug-in bridges that can easily be cut to the required length and quickly inserted in the bridge shafts. They eliminate the need for complicated and time-consuming loop bridges – the reduction in wiring by eliminating the need for modular terminal blocks and the use of all bridging options is around 60%.

### 1.3 Additional Advantages

- Switching power of up to 24 V DC/3 A, depending on the type
- IP67-protected fully encapsulated optical electronics
- Available with input or power solid-state relays as an option
- Integrated input circuit
- Solid-state relay can be replaced using an engagement lever
- Wear-resistant switching
- Resistant to vibrations and shocks
- Inflammability class V0 according to UL94





Make sure you always use the latest documentation.  
It can be downloaded at [www.download.phoenixcontact.com](http://www.download.phoenixcontact.com).  
A conversion table is available on the Internet at  
[www.download.phoenixcontact.com/general/7000\\_en\\_00.pdf](http://www.download.phoenixcontact.com/general/7000_en_00.pdf).



This data sheet is valid for all products listed on the following page:

## 2 Ordering Data

### PLC INTERFACE With Solid-State Relay, Sensor Version

Description	Type	Order No.	Pcs./Pck.	
PLC INTERFACE, comprising PLC-BSC...SEN basic terminal block and plug-in solid-state relay (see INTERFACE catalog), with screw connection, for mounting on 	24 V DC	PLCOSC- 24DC/48DC/100/SEN	2966773	10
	120 V AC/110 V DC	PLCOSC-120UC/48DC/100/SEN	2966799	10
	230 V AC/220 V DC <sup>1</sup>	PLCOSC-230UC/48DC/100/SEN	2966809	10
PLC INTERFACE, comprising PLC-BSP...SEN basic terminal block and plug-in solid-state relay (see INTERFACE catalog), with spring-cage connection, for mounting on 	24 V DC	PLCOSP- 24DC/48DC/100/SEN	2967578	10
	120 V AC/110 V DC	PLCOSP-120UC/48DC/100/SEN	2967581	10
	230 V AC/220 V DC <sup>1</sup>	PLCOSP-230UC/48DC/100/SEN	2967594	10

<sup>1</sup> The PLC-ATP BK insulating plate must be installed for voltages greater than 250 V (L1, L2, L3) between the same terminal points on adjacent modules (see "Accessories"). FBST 8-PLC... or FBST 500... is then used for potential bridging.



With the 120 V and 230 V modules, an OPT-60DC/... 60 V solid-state relay is normally used due to the input circuit integrated in the basic terminal block.  
For the protection of input and output, inductive loads must be dampened with an effective protective circuit.

### Accessories

Description	Type	Order No.	Pcs./Pck.
Insulating plate	PLC-ATP BK	2966841	25



The PLC-ATP BK insulating plate should be used in the following cases: always fit at the start and end of a PLC terminal strip for voltages greater than 250 V (L1, L2, L3) between the same terminal points on adjacent modules (FBST 8-PLC... or FBST 500... can be used for potential bridging) and for safe isolation between adjacent modules.

For additional accessories such as power terminal blocks and plug-in bridges, please refer to the INTERFACE catalog or [www.phoenixcontact.com](http://www.phoenixcontact.com).

## 3 Technical Data

Input Data	...24DC...	...120UC...	...230UC...
Nominal input voltage	24 V DC	120 V AC/110 V DC	230 V AC/220 V DC
Permissible range (with reference to $U_N$ )	0.8 ... 1.2 x $U_N$	0.8 ... 1.1 x $U_N$	
Switching level			
1 signal ("H")	0.8 x $U_N$	0.8 x $U_N$	
0 signal ("L")	0.4 x $U_N$	0.3 x $U_N$	
Typical input current at $U_N$	8 mA	4 mA	
Typical response time at $U_N$	20 $\mu$ s	6 ms	3 ms
Typical release time at $U_N$	300 $\mu$ s	10 ms	5 ms
Transmission frequency $f_{limit}$	300 Hz	10 Hz	
Input circuit	Yellow LED, protection against polarity reversal, free-wheeling diode	Yellow LED, bridge rectifier	

Output Data	
Maximum switching voltage	48 V DC
Minimum switching voltage	3 V DC
Limiting continuous current	100 mA
Output configuration	2-wire floating
Output circuit	Protection against polarity reversal, surge protection
Voltage drop at maximum limiting continuous current	$\leq 1$ V

**General Data**

Impulse voltage withstand level	2.5 kV, 50 Hz, 1 min.
Ambient temperature range	
Operation	-25°C ... 60°C (230 V type 20°C ... 55°C)
Storage/transport	-40°C ... 85°C
Nominal operating mode	100% operating factor
Inflammability class according to UL 94 (housing)	V0
Standards/specifications <sup>1</sup>	IEC 60664, IEC 60664 A, DIN VDE 0110 (basic insulation)
Pollution degree	2
Surge voltage category	III
Mounting position	Any
Mounting	Can be aligned without spacing
Conductor cross-section	
Solid, with screw connection	0.14 mm <sup>2</sup> ... 2.5 mm <sup>2</sup> (26 - 14 AWG)
Stranded, with screw connection	0.14 mm <sup>2</sup> ... 1.5 mm <sup>2</sup> (26 - 14 AWG)
Solid, with spring-cage connection	0.2 mm <sup>2</sup> ... 2.5 mm <sup>2</sup> (24 - 14 AWG)
Stranded, with spring-cage connection	0.2 mm <sup>2</sup> ... 1.5 mm <sup>2</sup> (24 - 14 AWG)
Stripping length	
Screw connection	10 mm
Spring-cage connection	8 mm
Dimensions (W x H x D)	6.2 mm x 94 mm x 80 mm
Housing material	Polyamide PA, green

<sup>1</sup> The PLC-ATP BK insulating plate must be installed for safe isolation between adjacent modules (see "Accessories"). FBST 8-PLC... or FBST 500... is then used for potential bridging.

**Tests/Approvals**

CE	CE
UL	UL <sup>1</sup> c, UL <sup>1</sup> US
GL	GL

**4 Block Diagram**

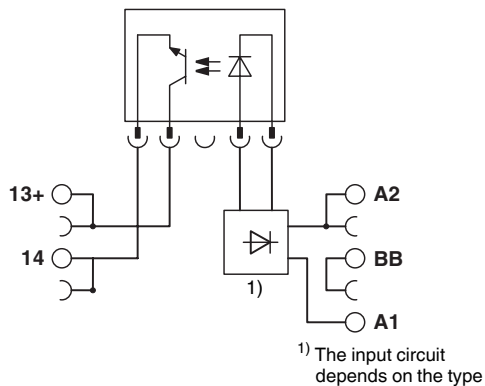

**5 Derating Curve**

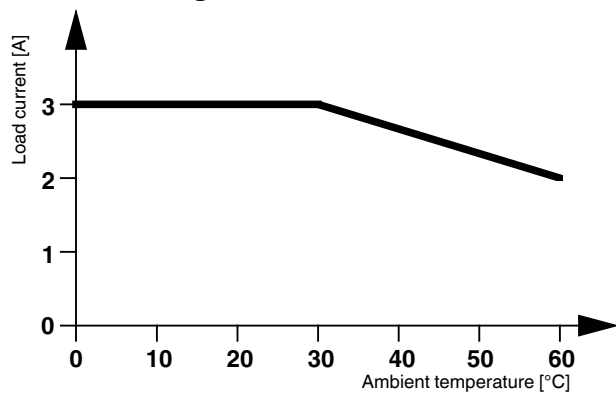

Компания «Life Electronics» занимается поставками электронных компонентов импортного и отечественного производства от производителей и со складов крупных дистрибьюторов Европы, Америки и Азии.

С конца 2013 года компания активно расширяет линейку поставок компонентов по направлению коаксиальный кабель, кварцевые генераторы и конденсаторы (керамические, пленочные, электролитические), за счёт заключения дистрибьюторских договоров

Мы предлагаем:

- Конкурентоспособные цены и скидки постоянным клиентам.
- Специальные условия для постоянных клиентов.
- Подбор аналогов.
- Поставку компонентов в любых объемах, удовлетворяющих вашим потребностям.
- Приемлемые сроки поставки, возможна ускоренная поставка.
- Доставку товара в любую точку России и стран СНГ.
- Комплексную поставку.
- Работу по проектам и поставку образцов.
- Формирование склада под заказчика.
- Сертификаты соответствия на поставляемую продукцию (по желанию клиента).
- Тестирование поставляемой продукции.
- Поставку компонентов, требующих военную и космическую приемку.
- Входной контроль качества.
- Наличие сертификата ISO.

В составе нашей компании организован Конструкторский отдел, призванный помогать разработчикам, и инженерам.

Конструкторский отдел помогает осуществить:

- Регистрацию проекта у производителя компонентов.
- Техническую поддержку проекта.
- Защиту от снятия компонента с производства.
- Оценку стоимости проекта по компонентам.
- Изготовление тестовой платы монтаж и пусконаладочные работы.



Тел: +7 (812) 336 43 04 (многоканальный)  
Email: [org@lifeelectronics.ru](mailto:org@lifeelectronics.ru)