



Main

Range of product	OsiSense XU
Series name	Application food and beverage
Electronic sensor type	Photo-electric sensor
Sensor name	XU2
Sensor design	Cylindrical M18
Detection system	Thru beam
Material	Stainless steel
Line of sight type	90° lateral
Type of output signal	Discrete
Supply circuit type	DC
Wiring technique	3-wire
Discrete output type	NPN
Discrete output function	1 NO or 1 NC programmable
Electrical connection	Cable
Cable length	6.56 ft (2 m)
Product specific application	-
Emission	Infrared thru beam
[Sn] nominal sensing distance	49.21 ft (15 m) thru beam

Complementary

Enclosure material	Stainless steel : 304 CU
Lens material	PMMA
Maximum sensing distance	65.62 ft (20 m)
Output type	Solid state
Add on output	Without
Add on input	Breaking test + programming
Cable composition	4 x 0.34 mm ²
Wire insulation material	PvR
Cable outer diameter	0.17 in (4.2 mm)
Status LED	1 LED (green) supply on 1 LED (yellow) output state
[Us] rated supply voltage	12...24 V DC with reverse polarity protection
Supply voltage limits	10...30 V DC
Switching capacity in mA	<= 100 mA (overload and short-circuit protection)
Switching frequency	<= 500 Hz
Voltage drop	<= 1.5 V (closed state)
Current consumption	<= 50 mA (no-load)
Delay first up	<= 15 ms
Delay response	<= 1 ms
Delay recovery	<= 1 ms
Setting-up	Without sensitivity adjustment
Diameter	0.71 in (18 mm)
Length	3.07 in (78 mm)
Product weight	0.6 lb(US) (0.27 kg)
Kit composition	Transmitter + receiver

Environment

product certifications	CE
------------------------	----

CSA
UL

ambient air temperature for operation	-13...131 °F (-25...55 °C)
ambient air temperature for storage	-40...158 °F (-40...70 °C)
vibration resistance	25 gn, amplitude = +/- 1.5 mm (f = 10...55 Hz) conforming to IEC 60068-2-6
shock resistance	30 gn (duration = 11 ms) conforming to IEC 60068-2-27
IP degree of protection	IP67 conforming to IEC 60529

Offer Sustainability

Not Green Premium product	Not Green Premium product
Will be Compliant on 3Q2013	Will be Compliant on 3Q2013 Will be Compliant on 3Q2013
Available	Available
Available	Available
WARNING: This product can expose you to chemicals including:	WARNING: This product can expose you to chemicals including:
Diisononyl phthalate (DINP), which is known to the State of California to cause cancer, and	Diisononyl phthalate (DINP), which is known to the State of California to cause cancer, and
Di-isodecyl phthalate (DIDP), which is known to the State of California to cause birth defects or other reproductive harm.	Di-isodecyl phthalate (DIDP), which is known to the State of California to cause birth defects or other reproductive harm.
For more information go to www.p65warnings.ca.gov	For more information go to www.p65warnings.ca.gov

Contractual warranty

Warranty period	18 months
-----------------	-----------

Dimensions

Transmitter's Dimensions

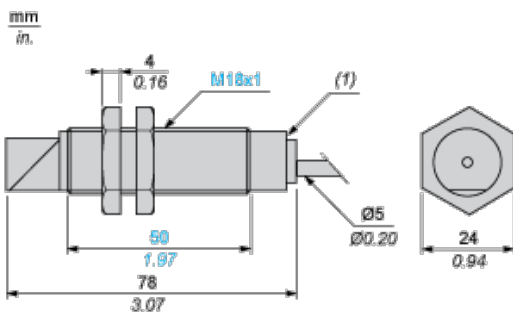

(1) LED

Receiver's Dimensions

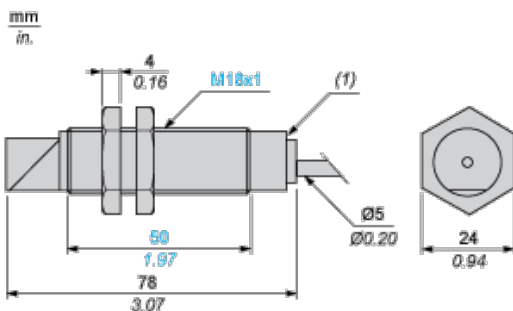

(1) LED

Mounting and Clearance

Fixing nut tightening torque: < 15 N.m

Connector tightening torque: 2 N.m

Wiring Schemes

Transmitter

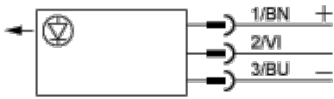

BN : Brown

VI : Violet (beam break input)

BU : Blue

3-wire, NPN NO or NC Programmable Function

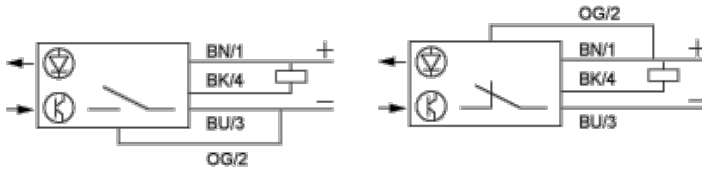

BN : Brown

BK : Black (out / output)

BU : Blue

OG : Orange (program)

Wiring Schemes

Beam Break Input on Thru-beam Transmitter

Beam made

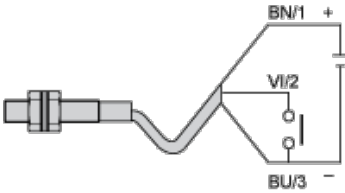

BN : Brown

VI : Violet (beam break input)

BU : Blue

Beam broken

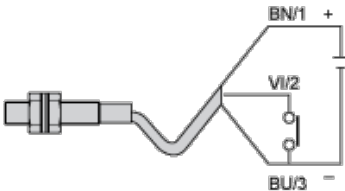

BN : Brown

VI : Violet (beam break input)

BU : Blue

Detection Curves

Thru-beam System

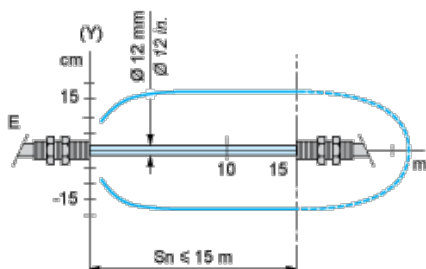

(y) \varnothing of beam

Excess Gain Curves (Ambient Temperature: + 25° C)

Thru-beam System

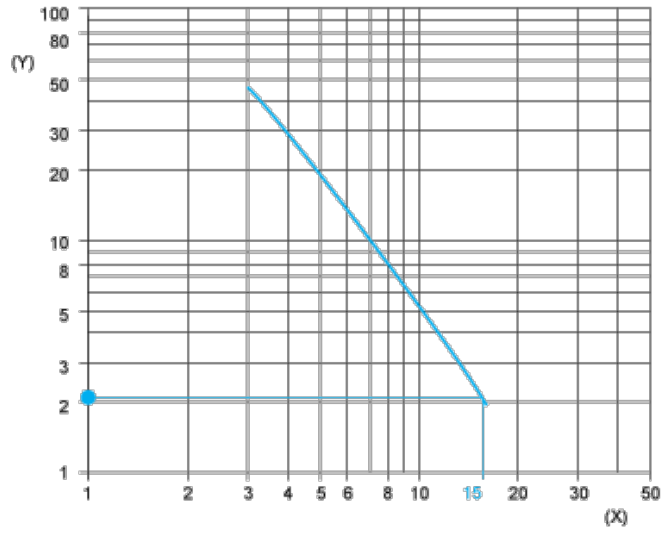

(y) Gain

(x) Distance (m)

Компания «Life Electronics» занимается поставками электронных компонентов импортного и отечественного производства от производителей и со складов крупных дистрибьюторов Европы, Америки и Азии.

С конца 2013 года компания активно расширяет линейку поставок компонентов по направлению коаксиальный кабель, кварцевые генераторы и конденсаторы (керамические, пленочные, электролитические), за счёт заключения дистрибьюторских договоров

Мы предлагаем:

- Конкурентоспособные цены и скидки постоянным клиентам.
- Специальные условия для постоянных клиентов.
- Подбор аналогов.
- Поставку компонентов в любых объемах, удовлетворяющих вашим потребностям.
- Приемлемые сроки поставки, возможна ускоренная поставка.
- Доставку товара в любую точку России и стран СНГ.
- Комплексную поставку.
- Работу по проектам и поставку образцов.
- Формирование склада под заказчика.
- Сертификаты соответствия на поставляемую продукцию (по желанию клиента).
- Тестирование поставляемой продукции.
- Поставку компонентов, требующих военную и космическую приемку.
- Входной контроль качества.
- Наличие сертификата ISO.

В составе нашей компании организован Конструкторский отдел, призванный помогать разработчикам, и инженерам.

Конструкторский отдел помогает осуществить:

- Регистрацию проекта у производителя компонентов.
- Техническую поддержку проекта.
- Защиту от снятия компонента с производства.
- Оценку стоимости проекта по компонентам.
- Изготовление тестовой платы монтаж и пусконаладочные работы.



Тел: +7 (812) 336 43 04 (многоканальный)

Email: org@lifeelectronics.ru