

DESCRIPTION

Demonstration circuit 773 is a synchronous buck-boost 1MHz Luxeon III white LED driver featuring the LTC3441 and LTC2050. The board is optimized for 3.9V LED forward voltage output at 1000mA load current and a single lithium-ion input voltage range of 3V to 4.2V. With its high frequency, synchronous buck-boost internal power switches, low quiescent current, 1MHz switching frequency and thermally enhanced package, the LTC3441 is a very versatile and powerful IC for driving Luxeon III LEDs that require both step-up and step-down capability from lithium-ion supplies used in very compact hand-held solutions.

The LTC3441 1MHz switching frequency allows all of the components to be small, surface mount devices. The current-mode control topology creates fast transient response and good loop stability with a minimum number of external components. The LED pushbutton is used to manually turn on the LED. The $\overline{\text{SHDN}}$ terminal can be used to program pulses of light from an external source for certain flash applications. The DIM terminal can be used to program the LED for dimmer operation than 1A LED current using a external PWM signal. The

optional MODE/SYNC terminal can be used to synchronize the LTC3441 clock with an external clock.

The LTC2050 is used to control a constant LED current at the output with the minimum amount of power dissipation in the sense resistor. The five-pin LTC2050IS5 is used for minimum components and minimum pins, but the LTC2050IS6 with a shutdown pin can be used for extremely low quiescent current. [1]

The LTC3441 and LTC2050 datasheets give complete descriptions of the parts including operation and applications information. The datasheets must be read in conjunction with this Quick Start Guide for demonstration circuit 773. The LTC3441 is assembled in a small 10-pin thermally enhanced package with exposed pad. Lumileds' LXHL-PW09 Luxeon III LED emitter has an exposed pad slug for thermal enhancement. Proper board layout is essential for maximum thermal performance. The LXHL-PW09 datasheet is found on Lumileds website www.lumileds.com.

Design files for this circuit board are available. Call the LTC factory.

Table 1. Typical Performance Summary ($T_A = 25^\circ\text{C}$)

PARAMETER	CONDITION	VALUE
Input Voltage Range		3–4.2V
LED OFF Input Current [1]	$V_{IN} = 3.6\text{V}$, U2 LTC2050IS6 w/ Shutdown [1]	1.4 μA
	$V_{IN} = 3.6\text{V}$, U2 LTC2050IS5 w/out Shutdown [1]	1.08mA
V_{LED}	$V_{IN} = 3\text{V}$ to 4.2V, LED ON, $I_{LED} = 1000\text{mA}$	3.9V
I_{LED}	$V_{IN} = 3\text{V}$ to 4.2V, LED ON	1000mA
LED Ripple Current	$V_{IN} = 3.6\text{V}$, LED ON, $I_{OUT} = 1000\text{mA}$	25mA _{PK-PK}
Switching Frequency	$V_{IN} = 3\text{V}$ to 4.2V, LED ON	1MHz
Efficiency	$V_{IN} = 3.6\text{V}$, $I_{LED} = 1000\text{mA}$, LED ON	84%
LED Brightness	$V_{IN} = 3.6\text{V}$, $I_{LED} = 1000\text{mA}$, LED ON	80LM

NOTE: [1] Replace LTC2050IS5 with LTC2050IS6 for low quiescent current during LED OFF. Tie $\overline{\text{SHDN}}$ pin of LTC2050IS6 to $\overline{\text{SHDN}}$ pin of LTC3441. DC773A is stuffed with LTC2050IS5 without a shutdown pin.

QUICK START PROCEDURE

Demonstration circuit 773 is easy to set up to evaluate the performance of the LTC3441 & LTC2050. Refer to Figure 1 for proper measurement equipment setup and follow the procedure below:

NOTE: Make sure that the input voltage does not exceed 4.2V.

NOTE: The shutdown function, dim function, and sync function are optional and their terminals can be left floating (disconnected) if not being used.

1. Connect the power supply (with power off), load, and meters as shown in Figure 1.
2. After all connections are made, turn on input power and verify that the LED turns on when the LED ON button is depressed.

NOTE: If the LED is not bright or not on, make sure that the current limit on the supply is not set too low.

3. Once the operation of the LED is established, adjust the supply within the operating range and observe the LED brightness, LED ripple, efficiency and other parameters.

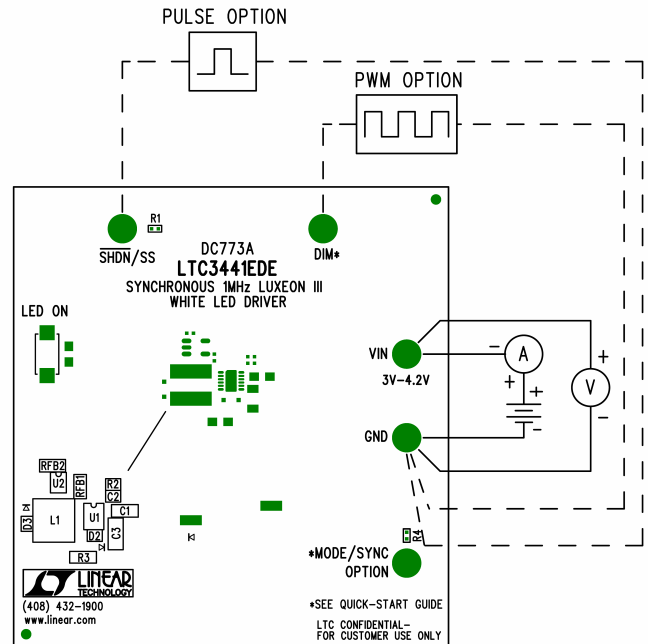

Figure 1. Proper Measurement Equipment Setup

OPTIONAL FUNCTIONS

SHUTDOWN / SOFT-START

The LED ON pushbutton is used to manually demonstrate how bright the LXHL-PW09 LED is with 1000mA of LED current. However, for some flash applications, a timed pulse is required. The SHDN terminal is used to attach an external pulsed source to drive the LED at 1000mA without pressing the LED ON pushbutton.

Please see the LTC3441 datasheet for the soft-start function and its implementation using the SHDN/SS terminal.

DIM

Demonstration Circuit 773 has a DIM terminal for dimming the LED. Typically the LED provides 80LM with 1A constant current. However, for less current, the DIM function may be used by switching in a lower resistance in the feedback path. Figure 2 demonstrates where to add the parallel dimming resistor. For 50% dimming,

QUICK START GUIDE FOR DEMONSTRATION CIRCUIT 773

SYNCHRONOUS 1MHZ LUXEON III WHITE LED DRIVER

use a 10.0k resistor for RDIM. The scale of LED current versus the parallel impedance of RFB1 and RDIM is fairly proportional.

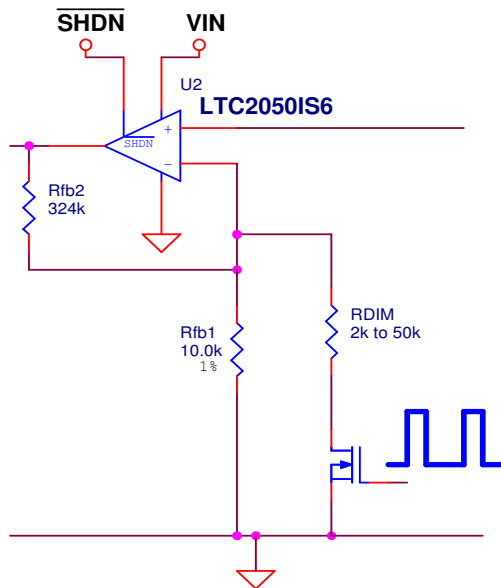

Figure 2. Implementation of the DIM function for lower LED current.

MODE / SYNCHRONIZATION OPTION

Burst mode is not used for the high current LED driver since the two states of the driver are high load current and shutdown. The Mode/Sync pin is tied to ground through the pads of R4 on the PCB. For use of the Mode/Sync functions, this connection to ground must be cut with an Exacto knife (cut the trace connected pins 1 and 2 of R4). Once the trace has been cut, the Mode/Sync pin can be reconnected to ground using a zero ohm resistor in R4 to disable its function.

The board can be externally synchronized between 1.15MHz and 1.7MHz using a synchronization signal twice the frequency of the desired switching frequency in the range of 2.3MHz to 3.4MHz. Please see the LTC3441 datasheet for details. For external synchronization, the connection to ground from the Mode/Sync pin must be severed as described above and R4 must be left unstuffed.

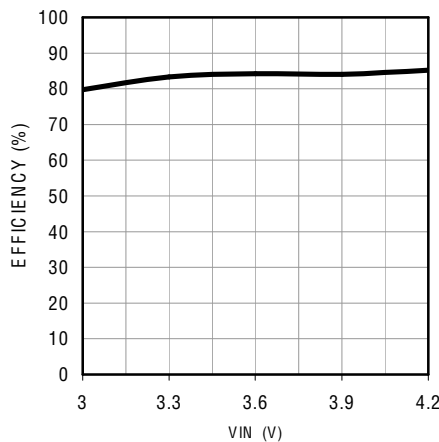

Figure 3. DC773 Typical Efficiency ($T_A = 25^\circ\text{C}$)

QUICK START GUIDE FOR DEMONSTRATION CIRCUIT 773

SYNCHRONOUS 1MHZ LUXEON III WHITE LED DRIVER

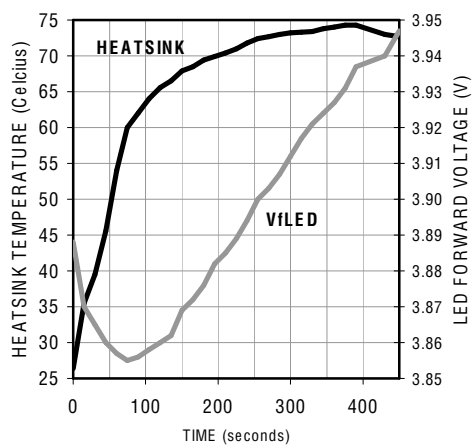

Figure 4. DC773 LED Forward Voltage Increases as Heatsink Temperature Increases.

QUICK START GUIDE FOR DEMONSTRATION CIRCUIT 773

SYNCHRONOUS 1MHZ LUXEON III WHITE LED DRIVER

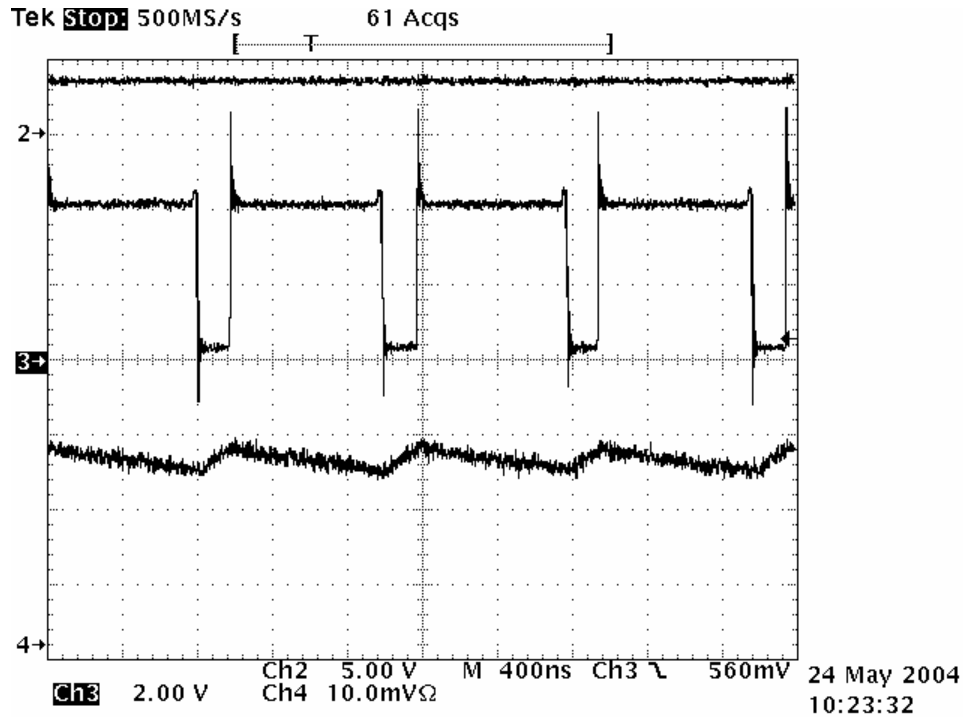

Figure 5. DC773 Switch Waveforms and Inductor Current at 3.6V_{IN}
(I_{LED} = 1000mA, V_{IN} = 3.6V, T_A = 25°C) CH2 is V_{SW1}, CH3 is V_{SW2}, CH4 is inductor current 500mA/10mVΩ

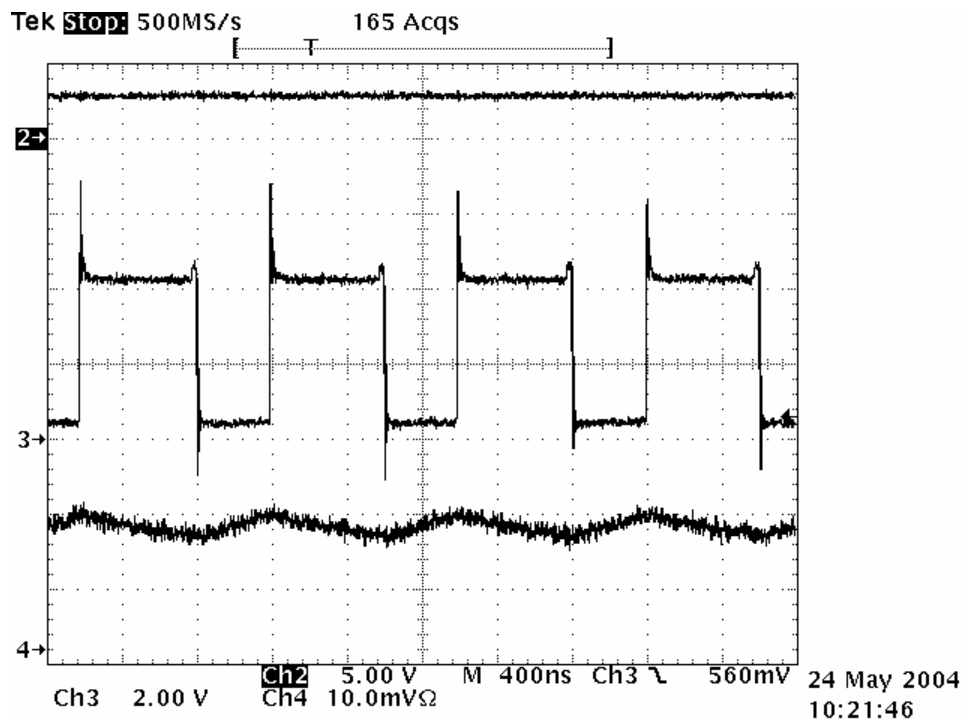

Figure 6. DC773 Switch Waveforms and Inductor Current at 3.0V_{IN} (I_{LED} = 1000mA, V_{IN} = 3.0V, T_A = 25°C)
CH2 is V_{SW1}, CH3 is V_{SW2}, CH4 is inductor current 1000mA/10mVΩ

QUICK START GUIDE FOR DEMONSTRATION CIRCUIT 773

SYNCHRONOUS 1MHZ LUXEON III WHITE LED DRIVER

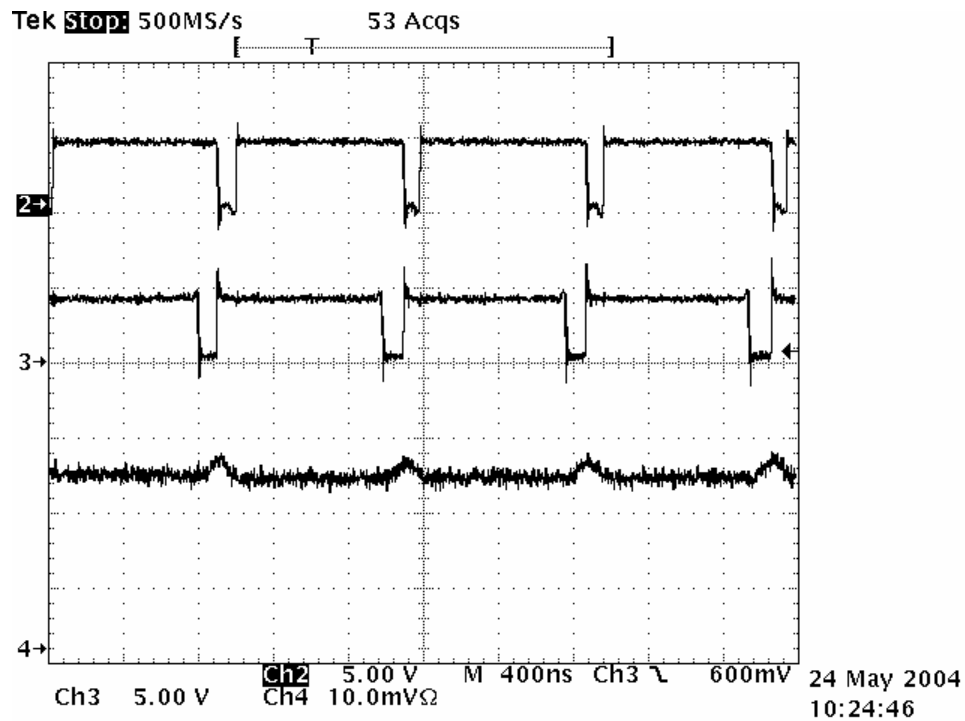

Figure 7. DC773 Switch Waveforms and Inductor Current at $4.2V_{IN}$ ($I_{LED} = 1000mA$, $V_{IN} = 4.2V$, $T_A = 25^\circ C$)
CH2 is V_{SW1} , CH3 is V_{SW2} , CH4 is inductor current 500mA/10mVΩ

QUICK START GUIDE FOR DEMONSTRATION CIRCUIT 773

SYNCHRONOUS 1MHZ LUXEON III WHITE LED DRIVER

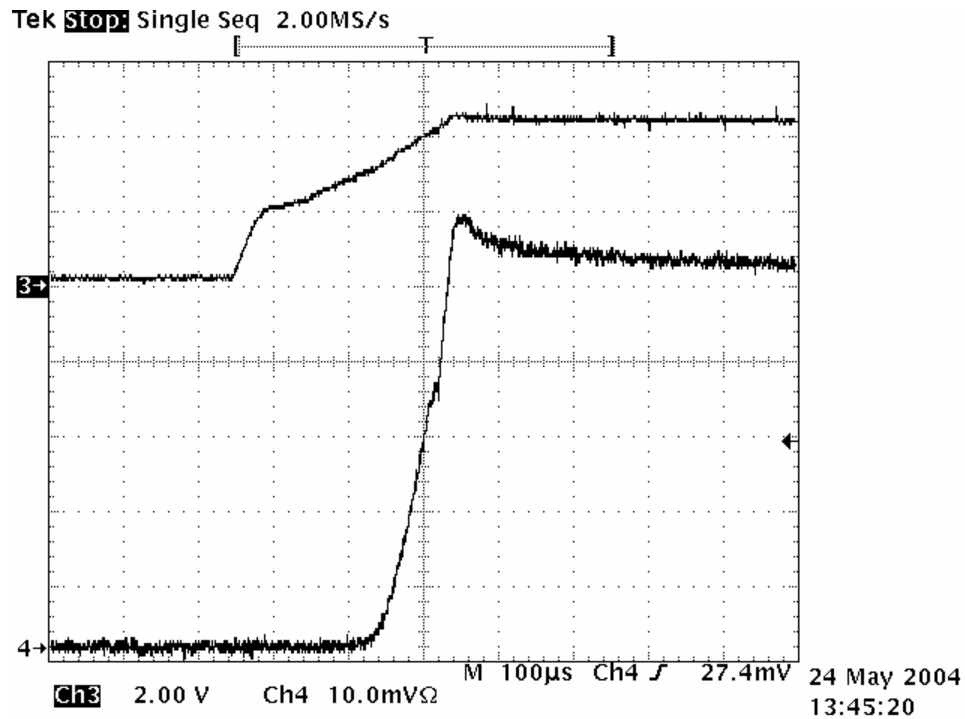

Figure 8. DC773 Turn-On Transient
($I_{LED} = 0\text{mA}$ to 1000mA , $V_{IN} = 3.6\text{V}$, $T_A = 25^\circ\text{C}$) CH3 is V_{LED} , CH4 is $I_{LED} 200\text{mA}/10\text{mV}\Omega$

QUICK START GUIDE FOR DEMONSTRATION CIRCUIT 773

SYNCHRONOUS 1MHZ LUXEON III WHITE LED DRIVER

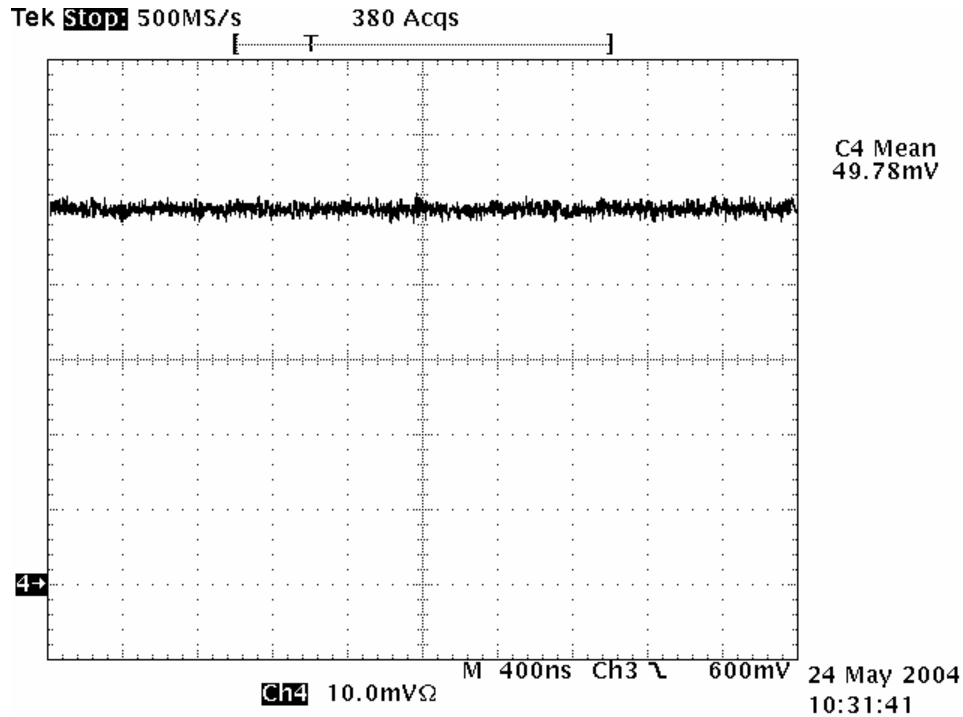

Figure 9. DC773 Constant Low-Ripple LED Current ($I_{LED} = 1000\text{mA}$, $V_{IN} = 3.6\text{V}$, $T_A = 25^\circ\text{C}$) CH4 is I_{LED} 200mA/10mVΩ

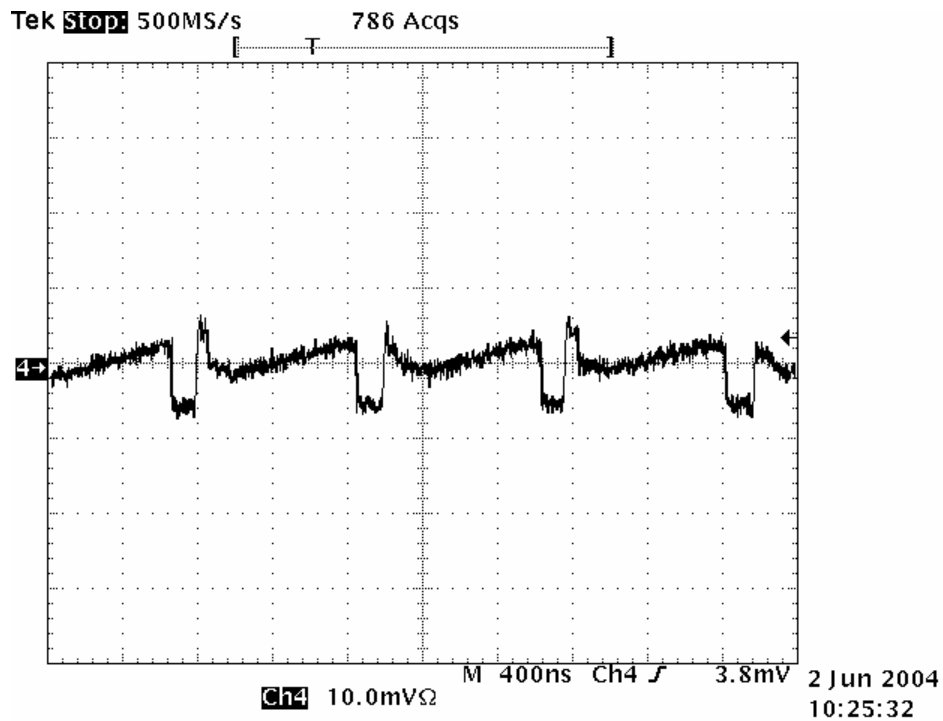
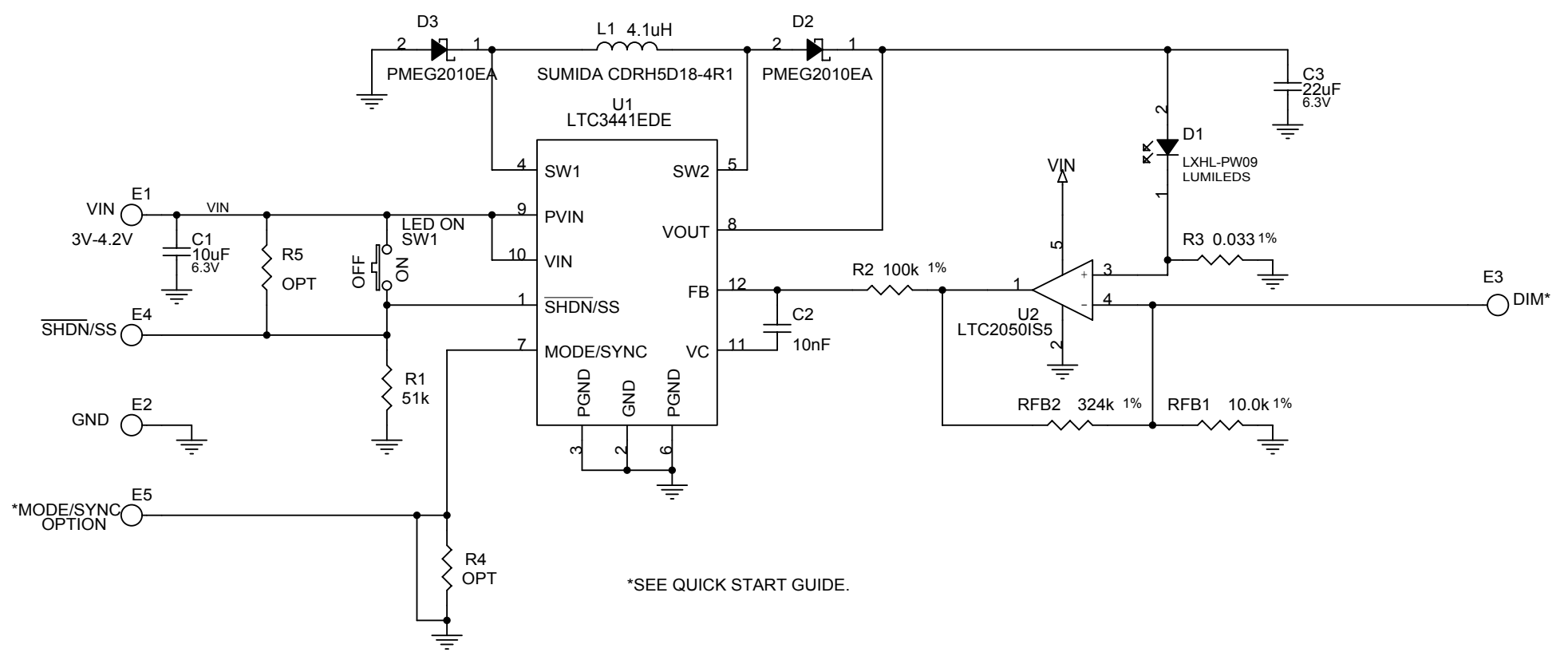

Figure 10. DC773 Constant Low-Ripple LED Current ($I_{LED} = 1000\text{mA}$, $V_{IN} = 3.6\text{V}$, $T_A = 25^\circ\text{C}$) CH4 is I_{LED} (AC) 20mA/10mVΩ

This circuit is proprietary to Linear Technology and supplied for use with Linear Technology parts.
Customer Notice Linear Technology has made a best effort to design a circuit that meets customer-supplied specifications; however, it remains the customers responsibility to verify proper and reliable operation in the actual application, Component substitution and printed circuit board layout may significantly affect circuit performance or reliability. Contact Linear Applications Engineering for assistance.

REVISION HISTORY				
ECO	REV	DESCRIPTION	DATE	APPROVED
	2	PROD	03/23/04	



*SEE QUICK START GUIDE.

CONTRACT NO.	
APPROVALS	DATE
DRAWN MEI	03/23/04
CHECKED	
APPROVED	
ENGINEER	
DESIGNER	
Monday, April 26, 2004	

1630 McCarthy Blvd.
 Milpitas, CA 95035
 Phone: (408)432-1900
 Fax: (408)434-0507

TITLE			
SCH, LTC3441EDE, SYNCHRONOUS 1MHz LUXEON III WHITE LED DRIVER			
SIZE	CAGE CODE	DWG NO	REV
		DC773A	2
SCALE:	FILENAME: 773A-2.DSN	SHEET 1	OF 1

<i>Item</i>	<i>Qty</i>	<i>Ref</i>	<i>Desc</i>	<i>Manufacturer's Part Number</i>
1	1	C1	CAP, X5R 10uF 6.3V 20% 0805	TDK C2012X5R0J106M
2	1	C2	CAP, X7R 10nF 16V 10% 0402	AVX 0402YC103KAT
3	1	C3	CAP, X5R 22uF 6.3V 20% 1206	TAIYO YUDEN JMK316BJ226ML-T
4	1	D1	LED, WHITE, LUXEON III EMITTER	LUMILEDS LXHL-PW09
5	2	D2,D3	DIODE, SCHOTTKY BARRIER	PHILIPS PMEG2010EA
6	4	E1,E2,E3,E4	TURRETS	MILL-MAX-2501-2
7	0	R4,E5	DO NOT STUFF	OPTION
8	1	L1	INDUCTOR, 4.1uH	SUMIDA CDRH5D18-4R1
9	1	RFB1	RES, 10.0K OHMS 1% 1/16W 0402	AAC CR05-1002FM
10	1	RFB2	RES, 324K OHMS 1% 1/16W 0402	AAC CR05-3243FM
11	1	R1	RES, 51K OHMS 5% 1/16W 0402	AAC CR05-513JM
12	1	R2	RES, 100K OHMS 1% 1/16W 0402	AAC CR05-1003FM
13	1	R3	RES, 0.033 OHMS 1% 1/16W 0805	THIN-FILM RL1220TR033F
14	1	SW1	SWITCH, MOMENTARY, PUSH BUTTON	PANASONIC EVQ PJS 05K
15	1	U1	IC, LTC3441EDE	LINEAR TECH. LTC3441EDE
16	1	U2	IC, LTC2050IS5	LINEAR TECH. LTC2050IS5
17	A/R		EPOXY, DP-190 3M GRAY 1.7FL.OZ. KIT WITH 1:1 PLUNGER	3M 021200-22647
18	1		APPLICATOR, EPX PLUS II 3M 50mL	3M 021200-50004
19	1		NOZZLE, EPX PUS II MIX NOZZLE 50mL	3M VB 02100-50009

Компания «Life Electronics» занимается поставками электронных компонентов импортного и отечественного производства от производителей и со складов крупных дистрибьюторов Европы, Америки и Азии.

С конца 2013 года компания активно расширяет линейку поставок компонентов по направлению коаксиальный кабель, кварцевые генераторы и конденсаторы (керамические, пленочные, электролитические), за счёт заключения дистрибьюторских договоров

Мы предлагаем:

- Конкурентоспособные цены и скидки постоянным клиентам.
- Специальные условия для постоянных клиентов.
- Подбор аналогов.
- Поставку компонентов в любых объемах, удовлетворяющих вашим потребностям.
- Приемлемые сроки поставки, возможна ускоренная поставка.
- Доставку товара в любую точку России и стран СНГ.
- Комплексную поставку.
- Работу по проектам и поставку образцов.
- Формирование склада под заказчика.
- Сертификаты соответствия на поставляемую продукцию (по желанию клиента).
- Тестирование поставляемой продукции.
- Поставку компонентов, требующих военную и космическую приемку.
- Входной контроль качества.
- Наличие сертификата ISO.

В составе нашей компании организован Конструкторский отдел, призванный помогать разработчикам, и инженерам.

Конструкторский отдел помогает осуществить:

- Регистрацию проекта у производителя компонентов.
- Техническую поддержку проекта.
- Защиту от снятия компонента с производства.
- Оценку стоимости проекта по компонентам.
- Изготовление тестовой платы монтаж и пусконаладочные работы.



Тел: +7 (812) 336 43 04 (многоканальный)

Email: org@lifeelectronics.ru