

SMA Connectors

Product Facts

- Performance to 12.4 GHz and beyond
- Available in various base metal options, including stainless steel, brass and zinc diecast
- Uses industry standard crimp tools and processes
- Available with corrosion resistant, non-magnetic White Bronze plating
- Meets all performance requirements for MIL-C-39012.



Tyco Electronics offers a complete line of SMA connectors designed for performance to 18 GHz to satisfy the growing demand for SMA connectors in the wireless communications industry. The SMA product line offers stainless steel bodies, as well as non-ferrous metals. Various plating options are available, including Gold and White Bronze. The SMA interface is fully compatible with Mil-C-39012.

While still offering various options on military (QPL) approved connectors, Tyco Electronics has developed a complete offering tailored to the commercial Communications industry. This includes 3 piece flexible cable products for popular RG 316, 142 and RD

316 cable utilizing industry standard HEX crimps.

The SMA series meets the performance, quality and application requirements of the commercial marketplace. This includes White Bronze plating, a unique finish developed by Tyco Electronics to address the performance needs of the telecommunications market. This plating is highly resistant to wear, and contains no ferrous metals, thus displaying excellent inter-modulation characteristics.

To satisfy the broad range of commercial applications, SMA connectors are available in a broad range of standard configurations including; straight and right-angle cable applied plugs, bulkhead cable jacks, two and four hole

flange mount panel jacks, straight and right-angle pcb mount jacks and various between and in series adapters. Numerous packaging and testing options are also available to meet specific system criteria as well.

Additionally, standard military approved (QPL) interfaces are offered as well. Including connectors for semi-rigid cable and micro strip applications.

The 3 Piece SMA offering is designed especially for applications in cellular infrastructure where InterModulation Products (IMP) must be minimized. By limiting non-linearities within the connectors, IMP is reduced and increased channel capacity can be offered.

Between Series Adapters

For SMA Between Series Adapters, see pages 251-260.

SMA Connectors (Continued)

Specifications

MIL-C-39012 Applicable Paragraph		
General		
Material	3.3	Steel corrosion resistant per ASTM-A-582 and ASTM-A-484, Type 303. Beryllium copper per ASTM-B-196. PTFE Fluorocarbon per ASTM-D-1710.
Finish	3.3.1	Center contacts shall be gold plated to a min. thickness of .00127 [.00005] in accordance with MIL-G-45204, ASTM-B-488. All other metal parts shall be finished as to provide a connector which meets the corrosion requirements.
Design	3.4	The design shall be such that the outline shown in this catalog and the interface dimensions of MIL-STD-348A are met.
Electrical		
Insulation Resistance	3.11	The insulation resistance shall not be less than 10,000 megohms.
Corona Level	3.22	Refer to applicable military slash sheet, product drawing or spec.
Dielectric Withstanding Voltage	3.17	Refer to applicable military slash sheet, product drawing or spec.
RF High Potential	3.23	Refer to applicable military slash sheet, product drawing or spec.
Contact Resistance	3.16	Refer to applicable military slash sheet, product drawing or spec.
VSWR	3.14	Refer to applicable military slash sheet, product drawing or spec. Frequency range dependent on cable used.
RF Leakage	3.26	Refer to applicable military slash sheet, product drawing or spec.
Insertion Loss	3.27	Refer to applicable military slash sheet, product drawing or spec. Frequency range dependent on cable used.
Mechanical		
Force to Engage	3.5.1	The torque required to engage and disengage shall not exceed 2 in.-lbs. The longitudinal force is not applicable.
Coupling Nut Retention	3.25	60 lbs. min. Applicable for plug connectors only.
Coupling Proof Torque	3.6	15 in.-lbs. min. Applicable for plug connectors only.
Cable Retention	3.24	Refer to applicable military slash sheet or consult factory.
Mating Characteristics	3.7	Applicable to jack connectors only. Reference MIL-STD-348A for dimensions; oversize test pin .953 [.0375] min. dia., .76 - 1.14 [.030-.045] deep, insertion force 3 lbs. max. with .940 [.0370] min. dia. pin, withdrawal force 1 oz. min. with .902 [.0355] max. dia. pin.
Connector Durability	3.15	The connector to be tested and its mating connector shall be subjected to 500 insertion and withdrawal cycles at 12 cycles per minute max. The connector shall show no evidence of mechanical failure and shall meet the mating characteristic requirements.
Recommended Mating Torque	—	7 to 10 in.-lbs.
Environmental		
Vibration	3.18	Specification MIL-STD-202, method 204, test condition D
Shock	3.19	Specification MIL-STD-202, method 213, test condition I
Thermal Shock	3.20	Refer to applicable military slash sheet or consult factory.
Corrosion (Salt Spray)	3.13	Specification MIL-STD-202, method 101, test condition B.
Moisture Resistance	3.21	Specification MIL-STD-202, method 106. No measurements at high humidity. Insulation resistance shall be at least 200 megohms within 5 minutes of removal from humidity.

SMA Connectors (Continued)
Electrical

Connector Type	Cable	Frequency Max. (GHz)	VSWR x (fGHz)	Contact Resistance (milliohms max.)		Insulation Resistance (megohms min.)	Dielectric Withstanding Voltage (Volts RMS)	Corona Extinction Voltage at 70,000 Ft. (V RMS min.)	RF Transmission Loss	RF High Potential at 5 MHz (V RMS)	RF Leakage (dB min.)
				Center Contact	Outer Contact						
Straight Cable Plug without Contact	RG 402 (3.58 [.141])	Note 1	1.02 + .005	N/A	2.0	10,000	N/A	250	N/A	670	-(90-fGHz)
	RG 405 (2.16 [.085])	18.0	1.05 + .005	2.0	2.0	10,000	1000	250	.03 \sqrt{f} (GHz)	670	-(90-fGHz)
Straight Cable Plugs & Jacks Solder Attachment	RG 402 (3.58 [.141])	18.0	1.05 + .005	2.0	2.0	10,000	1500	375	.03 \sqrt{f} (GHz)	1000	-(90-fGHz)
	3.58 [.141] Microporous	18.0	1.05 + .005	2.0	2.0	10,000	1500	375	.03 \sqrt{f} (GHz)	1000	-(90-fGHz)
	RG 401 (6.35 [.250])	18.0	1.07 + .007	2.0	2.0	10,000	1500	375	.03 \sqrt{f} (GHz)	1000	-(90-fGHz)
	RG 174, 188, 316	Note 1	1.15 + .01	2.0	2.0	10,000	750	190	.06 \sqrt{f} (GHz)	500	-(60-fGHz)
Straight Cable Plugs & Jacks Solder Clamp Attachment	RG 55, 58, 141, 142, 223, 303, 400	Note 1	1.10 + .005	2.0	2.0	10,000	1000	250	.06 \sqrt{f} (GHz)	670	-(60-fGHz)
	RG 405 (2.16 [.085])	12.4	1.10 + .015	2.0	2.0	10,000	1000	250	.03 \sqrt{f} (GHz)	670	-(90-fGHz)
Straight Cable Plugs & Jacks Solder Clamp Attachment	RG 402 (3.58 [.141])	12.4	1.07 + .01	2.0	2.0	10,000	1500	375	.03 \sqrt{f} (GHz)	1000	-(90-fGHz)
	RG 55, 58, 141, 142, 223, 400	Note 1	1.10 + .005	2.0	2.0	10,000	1000	250	.06 \sqrt{f} (GHz)	670	-(60-fGHz)
Straight Cable Plugs & Jacks Clamp Attachment	RG 174, 188, 316	Note 1	1.15 + .01	2.0	2.0	10,000	750	190	.06 \sqrt{f} (GHz)	500	-(60-fGHz)
	RG 180, 195	Note 1	—	2.0	2.0	10,000	750	190	—	500	-(60-fGHz)
	RG 55, 142, 223, 400	Note 1	1.10 + .005	2.0	2.0	10,000	1000	250	.06 \sqrt{f} (GHz)	670	-(60-fGHz)
Straight Cable Plugs & Jacks Crimp Attachment	RG 58, 141, 303	Note 1	1.10 + .005	2.0	2.0	10,000	1000	250	.06 \sqrt{f} (GHz)	670	-(60-fGHz)
	RG 174, 188, 316	Note 1	1.15 + .01	2.0	2.0	10,000	750	190	.06 \sqrt{f} (GHz)	500	-(60-fGHz)
	RG 180, 195	Note 1	—	2.0	2.0	10,000	750	190	—	500	-(60-fGHz)
	RG 178, 196	Note 1	1.2 + .02	2.0	2.0	10,000	500	125	.06 \sqrt{f} (GHz)	335	-(60-fGHz)
Straight Cable Plugs & Jacks Compression Clamp Attachment	RG 401 (6.35 [.250])	18.0	1.07 + .01	2.0	2.0	10,000	1500	375	.05 \sqrt{f} (GHz)	1000	-70 dB min.
	6.35 [.250] Microporous	18.0	1.07 + .01	2.0	2.0	10,000	1500	375	.05 \sqrt{f} (GHz)	1000	-70 dB min.
	6.35 [.250] 3 Spline	18.0	1.07 + .01	2.0	2.0	10,000	1500	375	.05 \sqrt{f} (GHz)	1000	-70 dB min.
	6.35 [.250] 5 Spline	18.0	1.07 + .01	2.0	2.0	10,000	1500	375	.05 \sqrt{f} (GHz)	1000	-70 dB min.
Right-Angle Cable Plugs Solder Attachment	RG 405 (2.16 [.085])	12.4	1.18 + .015	2.0	2.0	10,000	1000	250	.04 \sqrt{f} (GHz)	670	-(90-fGHz)
	RG 405 (2.16 [.085])	18.0	1.18 + .015	2.0	2.0	10,000	1000	250	.04 \sqrt{f} (GHz)	670	-(90-fGHz)
	RG 402 (3.58 [.141])	12.4	1.15 + .015	2.0	2.0	10,000	1500	325	.04 \sqrt{f} (GHz)	1000	-(90-fGHz)
	RG 402 (3.58 [.141])	18.0	1.10 + .010	2.0	2.0	10,000	1500	250	.05 \sqrt{f} (GHz)	1000	-(90-fGHz)
	RG 55, 58, 141, 142, 223, 303, 400	Note 1	1.15 + .01	2.0	2.0	10,000	1000	250	.07 \sqrt{f} (GHz)	670	-(60-fGHz)
	RG 174, 188, 316	Note 1	1.15 + .02	2.0	2.0	10,000	750	190	.07 \sqrt{f} (GHz)	500	-(60-fGHz)
Right-Angle Cable Plugs Crimp Attachment	RG 55, 142, 223, 400	Note 1	1.15 + .02	2.0	2.0	10,000	1000	250	.07 \sqrt{f} (GHz)	670	-(60-fGHz)
	RG 58, 141, 303	Note 1	1.15 + .02	2.0	2.0	10,000	1000	250	.07 \sqrt{f} (GHz)	670	-(60-fGHz)
	RG 174, 188, 316	Note 1	1.18 + .02	2.0	2.0	10,000	750	190	.07 \sqrt{f} (GHz)	500	-(60-fGHz)
	RG 180, 195	Note 1	—	2.0	2.0	10,000	750	190	—	500	-(60-fGHz)
Right-Angle Cable Plugs Clamp Attachment	RG 178, 196	Note 1	1.25 + .025	2.0	2.0	10,000	500	125	.07 \sqrt{f} (GHz)	335	-(60-fGHz)
	RG 55, 58, 141, 142, 223, 303	Note 1	1.10 + .005	2.0	2.0	10,000	1000	250	.08 \sqrt{f} (GHz)	670	-(60-fGHz)
	RG 174, 188, 316	Note 1	1.15 + .01	2.0	2.0	10,000	750	190	.08 \sqrt{f} (GHz)	500	-(60-fGHz)
Flange Mount Plugs & Jacks Panel or Bulkhead Mount	RG 180, 195	Note 1	—	2.0	2.0	10,000	750	190	—	500	-(60-fGHz)
	Non-Captured	18.0	1.03 + .004	2.0	2.0	10,000	1000	250	.03 \sqrt{f} (GHz)	670	-(100-fGHz)
	Epoxy Captured	18.0	1.05 + .005	2.0	2.0	10,000	1000	250	.03 \sqrt{f} (GHz)	670	-(60-fGHz)
	Mechanical Capture	18.0	1.04 + .004	2.0	2.0	10,000	1000	250	.03 \sqrt{f} (GHz)	670	-(100-fGHz)
Bulkhead Feedthrough Jacks	Field Replaceable Hermetic Launchers	18.0	1.04 + .006	2.0	2.0	10,000	1000	250	.04 \sqrt{f} (GHz)	670	-(100-fGHz)
	Epoxy Captured	18.0	1.07 + .010	2.0	2.0	10,000	1000	250	.04 \sqrt{f} (GHz)	670	-(60-fGHz)
Right-Angle Flange Mount Jacks	Mechanical Capture	18.0	1.07 + .010	2.0	2.0	10,000	1000	250	.04 \sqrt{f} (GHz)	670	-(100-fGHz)
	N/A	18.0	1.07 + .015	2.0	2.0	10,000	1000	250	.08 \sqrt{f} (GHz)	670	-(90-fGHz)
Printed Circuit Board Mount Straight Terminal	N/A	12.4	1.15 + .015	2.0	2.0	10,000	1000	250	.08 \sqrt{f} (GHz)	670	-(90-fGHz)
	N/A	18.0	N/A	2.0	2.0	10,000	1000	250	N/A	670	N/A
Right-Angle Printed Circuit	N/A	12.4	N/A	2.0	2.0	10,000	1000	250	N/A	670	N/A
End Launch Stripline Circuit	N/A	18.0	1.05 + .005	2.0	2.0	10,000	1000	250	.03 \sqrt{f} (GHz)	670	-(60-fGHz)
Surface Launch Stripline Circuit	N/A	18.0	1.05 + .005	2.0	2.0	10,000	1000	250	.03 \sqrt{f} (GHz)	670	-(60-fGHz)
Right-Angle Surface Launch Stripline Circuit	N/A	12.4	1.15 + .015	2.0	2.0	10,000	1000	250	.08 \sqrt{f} (GHz)	670	-(60-fGHz)
	N/A	18.0	1.07 + .015	2.0	2.0	10,000	1000	250	.08 \sqrt{f} (GHz)	670	-(60-fGHz)

1. Maximum operating frequency of cable per MIL-C-17.
2. Specifications do not apply to hermetic or compression crimp connectors.
3. For Brass SMA: Frequency Range DC-6GHz, Impedance 50 Ohms, Insulation Resistance.

SMA Connectors (Continued)

Interface Mating Dimensions

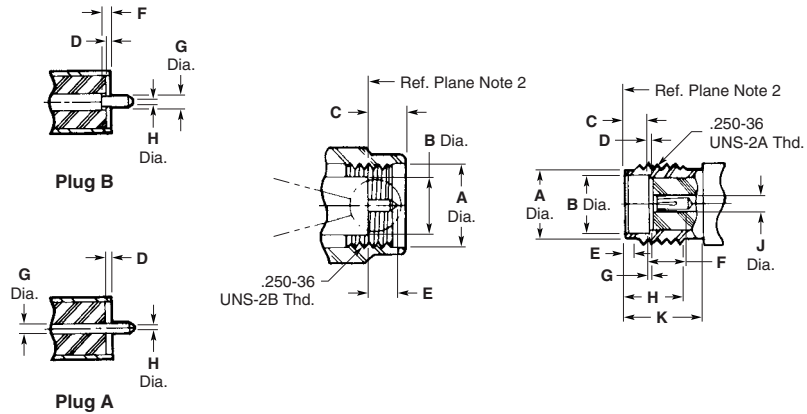

Plug

Dimension	Minimum	Maximum
A	6.35 .250	—
B	—	4.59 .1808
C	—	3.43 .135
D	0.00 .000	0.25 .010
E	—	2.54 .100
F	0.00 .000	0.25 .010
G	0.90 .0355	0.94 .037
H	0.00 .000	0.38 .015

Jack

Dimension	Minimum	Maximum
A	5.28 .208	5.49 .216
B	4.60 .181	—
C	1.91 .075	1.98 .078
D	0.00 .000	0.25 .010
E	0.38 .015	1.43 .045
F	2.92 .115	—
G	0.00 .000	0.25 .010
H	4.32 .170	—
J	1.24 .049	1.30 .051
K	5.54 .218	—

Notes:

1. ID to meet VSWR and contact resistance when mated with 0.51 +.025/-.013 [.036 +.0010/-.0005] Dia. Pin.
2. When fully engaged, the two reference planes must coincide with metal to metal contact.
3. Metric equivalents (to the nearest 0.01mm) are given for general information only.

SMA Connectors (Continued)
Flexible Cable

Straight Cable Plug, Solder

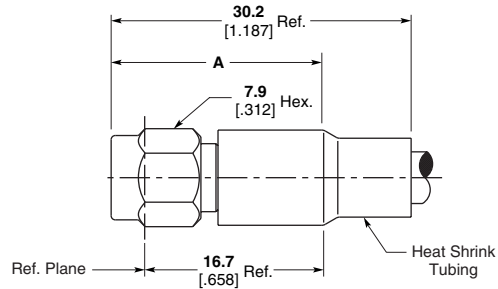

Cable Type RG/U	Body Material & Finish	Contact Captivation	Contact Attachment	Dimension A	Instruction Sheet	Part No.
55, 58, 141, 142, 223, 303, 400	Stainless, Gold ¹	No	Solder	19.7 .775	408-4821	1051638-1
174, 188, 316	Stainless, Gold ¹	No	Solder	17.5 .690	408-4756	1051644-1

¹Coupling nut is passivated stainless steel.

Straight Cable Jack, Solder

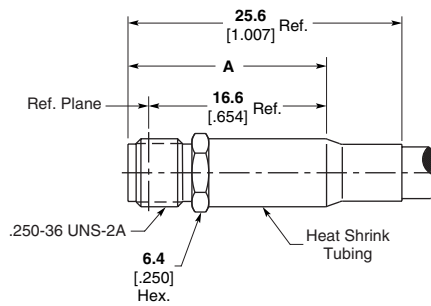

Cable Type RG/U	Body Material & Finish	Contact Captivation	Contact Attachment	Dimension A	Instruction Sheet	Part No.
55, 58, 141, 142, 223, 303, 400	Stainless, Gold	No	Solder	18.5 .730	408-4820	1051852-1

Bulkhead Cable Jack, Solder

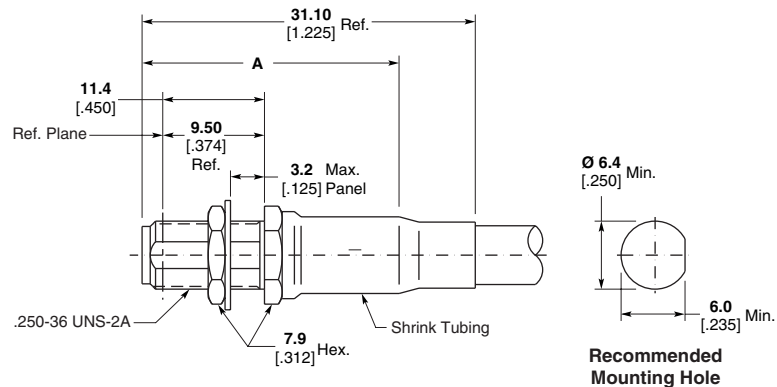

Cable Type RG/U	Body Material & Finish	Contact Captivation	Contact Attachment	Dimension A	Instruction Sheet	Part No.
RG 55, 58, 141, 142, 300	Stainless, Gold	No	Solder	24.0 .945	408-4817	1051861-1
174, 188, 316	Stainless, Gold	No	Solder	21.0 .825	408-4817	1051942-1

Note: Part Numbers are RoHS compliant except: ♦ Indicates non-RoHS compliant.

SMA Connectors (Continued)
Flexible Cable (Continued)

Right-Angle Cable Plug, Solder

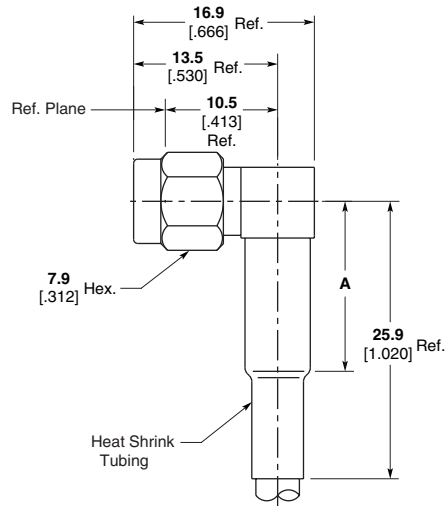

Cable Type RG/U	Body Material & Finish	Contact Captivation	Contact Attachment	Dimension A	Instruction Sheet	Part No.
55, 58, 141, 142, 223, 303, 400	Stainless, Gold ¹	Yes	Solder	16.0 .630	408-4816	1052063-1
174, 188, 316	Stainless, Gold ¹	Yes	Solder	11.2 .440	408-4815	1052067-1

¹Coupling nut is passivated stainless steel.

Straight Cable Plug, Clamp

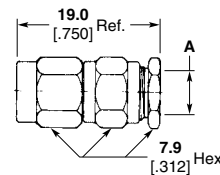

Cable Type RG/U	Body Material & Finish	Contact Captivation	Contact Attachment	Dimension A	Instruction Sheet	Part No.
174, 188, 316	Stainless, Pass.	Yes	Solder	2.9 .116	408-4906	1050721-1

Straight Cable Jack, Clamp

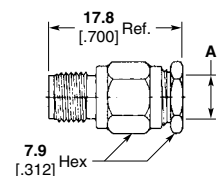

Cable Type RG/U	Body Material & Finish	Contact Captivation	Contact Attachment	Dimension A	Instruction Sheet	Part No.
174, 188, 316	Stainless, Pass.	Yes	Solder	2.9 .116	408-4906	1050903-1

Note: Part Numbers are RoHS compliant except: ♦ Indicates non-RoHS compliant.

SMA Connectors (Continued)
Flexible Cable (Continued)

Bulkhead Feedthrough Cable Jack, Clamp

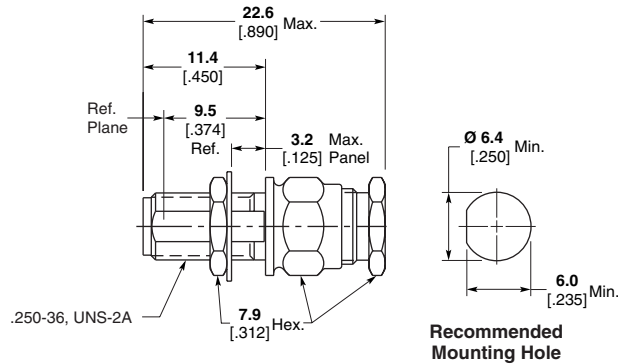

Cable Type RG/U	Body Material & Finish	Contact Captivation	Contact Attachment	Instruction Sheet	Part No.
174, 188, 316	Stainless, Pass.	Yes	Solder	408-4704	1050996-1

Right-Angle Cable Plug, Clamp

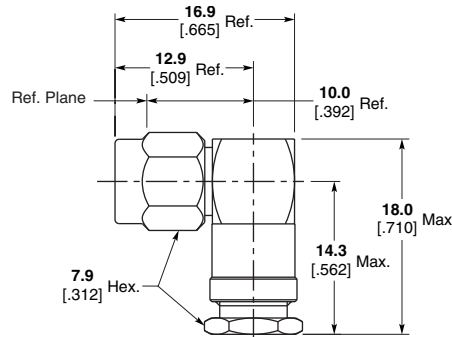

Cable Type RG/U	Body Material & Finish	Contact Captivation	Contact Attachment	Instruction Sheet	Part No.
174, 188, 316	Stainless, Pass.	Mechanical	Solder	408-4965	1051140-1

Straight Cable Plug, Crimp

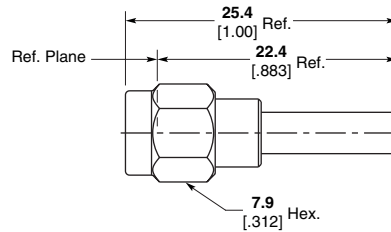

Cable Type RG/U	Body Material & Finish	Contact Captivation	Contact Attachment	Crimp Tooling Part No.	Instruction Sheet	Part No.
174, 179, 187, 188, 316	Stainless, Pass.	Mechanical	Solder/Crimp ²	1055236-1	408-4661	1056443-1
RD316	Stainless, Pass.	Mechanical	Solder/Crimp ²	1055236-1 ¹	408-4661	1056436-1
55, 142, 223, 400	Stainless, Pass.	Mechanical	Solder/Crimp ²	1055236-1	408-4661	1056438-1
174, 179, 187, 188, 316	Brass, White Bronze	Mechanical	Solder/Crimp ²	1055236-1	408-4661	1082034-1

¹Use die 1055270-1 to crimp RD316 ferrule.
²Use die 1055880-1 to crimp center contact.

Note: Part Numbers are RoHS compliant except: ♦ Indicates non-RoHS compliant.

SMA Connectors (Continued)
Flexible Cable (Continued)

Straight Cable Jack, Crimp

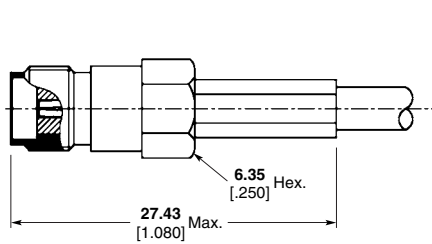

Style A

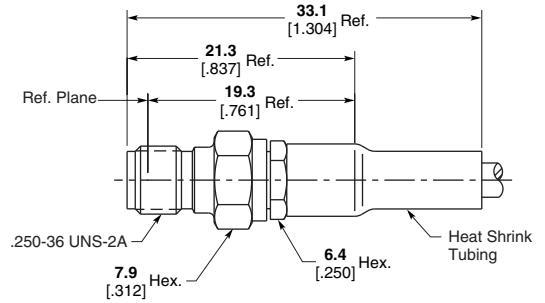

Style B

Cable Type RG/U	Body Material & Finish	Contact Captivation	Contact Attachment	Crimp Tooling Part No.	Instruction Sheet	Style	Part No.
174, 316	Brass, Nickel	Mechanical	Solder	1	408-4032	A	5447648-3
58, 141, 303	Stainless, Pass.	Mechanical	Solder	1055236-1	408-4704	B	1051867-1
174, 188, 316	Stainless, Pass.	Mechanical	Solder	1055236-1	408-4708	B	1051855-1
178, 196	Stainless, Pass.	Mechanical	Solder	1055236-1	408-4806	B	1051869-1

¹Refer to Tyco Electronics Customer Print for tooling requirement. DANIELS Mil Tooling used for contact and ferrule crimp.

**Bulkhead Feedthrough
Cable Jack, Crimp**

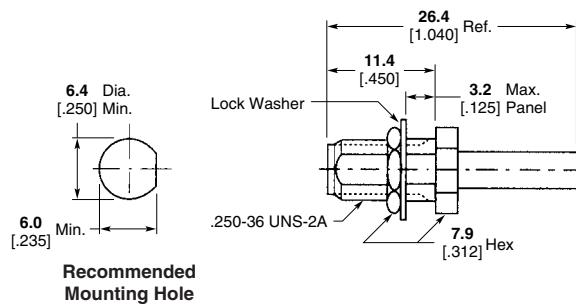

Recommended
Mounting Hole

Cable Type RG/U	Body Material & Finish	Contact Captivation	Contact Attachment	Crimp Tooling Part No.	Instruction Sheet	Part No.
174, 179, 187, 188, 316	Stainless, Pass.	Mechanical	Solder/Crimp ²	1055236-1	408-4661	1056452-1
RD316	Stainless, Pass.	Mechanical	Solder/Crimp ²	1055236-1 ³	408-4661	1056445-1
58, 141, 303	Stainless, Pass.	Mechanical	Solder/Crimp ²	1055236-1	408-4661	1056450-1
55, 142, 223, 400	Stainless, Pass.	Mechanical	Solder/Crimp ²	1055236-1	408-4661	1056447-1
174, 188, 316	Brass, Nickel	Mechanical	Crimp	1	408-4032	5448103-2

¹Refer to Tyco Electronics Customer Print for tooling requirement. DANIELS Mil Tooling used for contact and ferrule crimp.

²Use die 1055880-1 to crimp center contact.

³Use die 1055270-1 to crimp RD316 ferrule.

DANIELS is a trademark of Daniels Manufacturing Corporation.

Note: Part Numbers are RoHS compliant except: ♦ Indicates non-RoHS compliant.

SMA Connectors (Continued)
Flexible Cable (Continued)

Right-Angle Cable Plug, Crimp

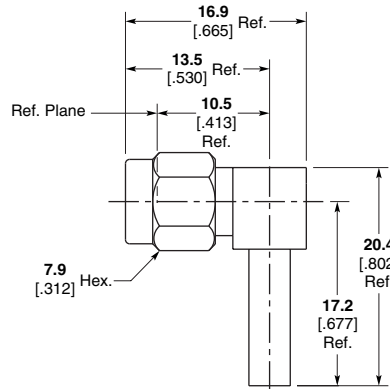

Cable Type RG/U	Body Material & Finish	Contact Captivation	Contact Attachment	Crimp Tooling Part No.	Instruction Sheet	Part No.
174, 179, 187, 188, 316	Stainless, Pass.	Mechanical	Solder	1055236-1	408-4659	1056462-1
58, 141, 303	Stainless, Pass.	Mechanical	Solder	1055236-1	408-4659	1056456-1

Right-Angle Cable Plug, Crimp

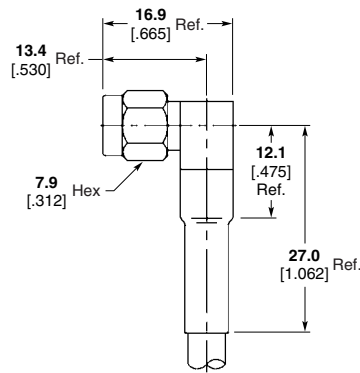

Cable Type RG/U	Body Material & Finish	Contact Captivation	Contact Attachment	Crimp Tooling Part No.	Instruction Sheet	Part No.
55, 142, 223, 400	Stainless, Pass.	Epoxy	Solder	1055236-1	408-4681	1052072-1
174, 188, 316	Stainless, Pass.	Epoxy	Solder	1055236-1	408-4683	1052076-1
178, 196	Stainless, Pass.	Epoxy	Solder	1055236-1	408-4801	1052098-1

Note: Part Numbers are RoHS compliant except: ♦ Indicates non-RoHS compliant.

SMA Connectors (Continued)
Flexible Cable (Continued)

Straight Push-On

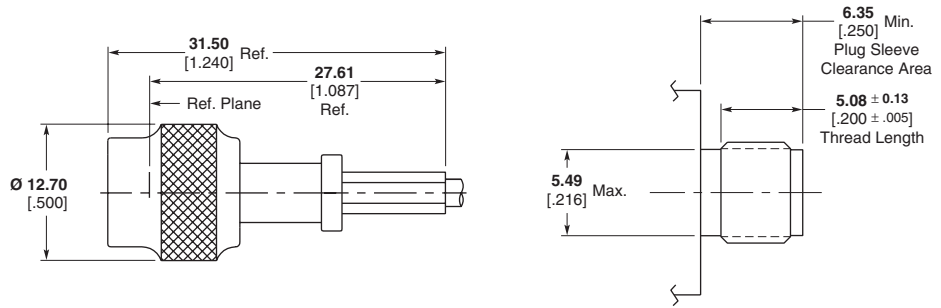

Cable Type RG/U	Body Material & Finish	Contact Captivation	Contact Attachment	Part No.
316	Beryllium Copper, Gold	Mechanical	Crimp	1408541-1

Right-Angle Push-On

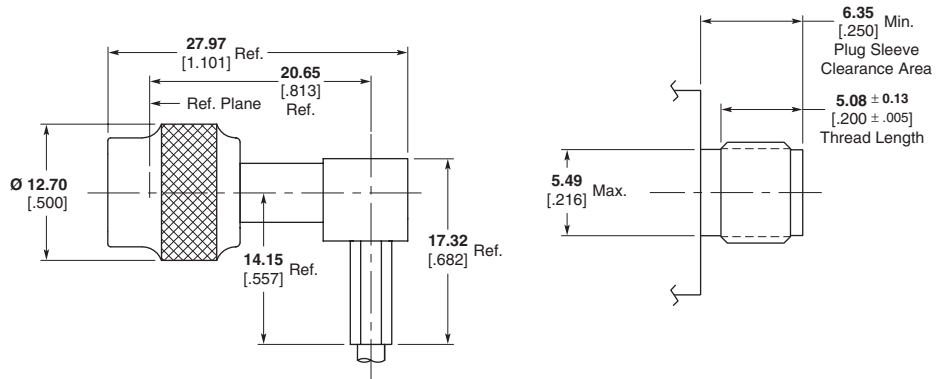

Cable Type RG/U	Body Material & Finish	Contact Captivation	Contact Attachment	Part No.
316	Beryllium Copper, Gold	Mechanical	Solder/Crimp	1274694-1

Note: Part Numbers are RoHS compliant except: ♦ Indicates non-RoHS compliant.

SMA Connectors (Continued)
Direct Solder Attachment, Semi-Rigid Cable

Straight Cable Plug

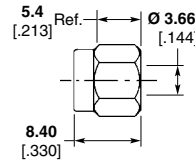

Cable Type RG/U	Body Material & Finish	Contact Captivation	Contact Attachment	Solder Assembly Kit Part No.	Instruction Sheet	Part No.
402 (3.58 [0.141])	Stainless, Pass.	No Center Contact	No Center Contact	1055420-1	408-4761	1050757-1

Straight Cable Plug

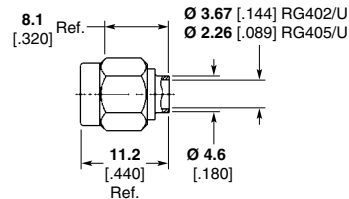

Cable Type RG/U	Body Material & Finish	Contact Captivation	Contact Attachment	Solder Assembly Kit Part No.	Instruction Sheet	Part No.
402 (3.58 [0.141])	Stainless, Gold ¹	No	Solder	1055420-1	408-4764	1050525-1
405 (2.16 [0.085])	Stainless, Gold ¹	No	Solder	1055420-1	408-4765	1050770-1
402 (3.58 [0.141])	Stainless, Gold ¹	No Center Contact	No Center Contact	N/A	—	1050542-1
405 (2.16 [0.085])	Stainless, Gold ¹	No	Solder	1055420-1	—	1050548-1

¹Coupling nut is passivated stainless steel.

Straight Cable Jack

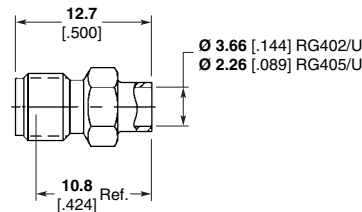

Cable Type RG/U	Body Material & Finish	Contact Captivation	Contact Attachment	Solder Assembly Kit Part No.	Instruction Sheet	Part No.
402 (3.58 [0.141])	Stainless, Gold	No	Solder	1055420-1	408-4767	1050854-1
405 (2.16 [0.085])	Stainless, Gold	No	Solder	1055420-1	408-4833	1050859-1

Note: Part Numbers are RoHS compliant except: ♦ Indicates non-RoHS compliant.

SMA Connectors (Continued)
Direct Solder Attachment, Semi-Rigid Cable (Continued)

Bulkhead Cable Jack

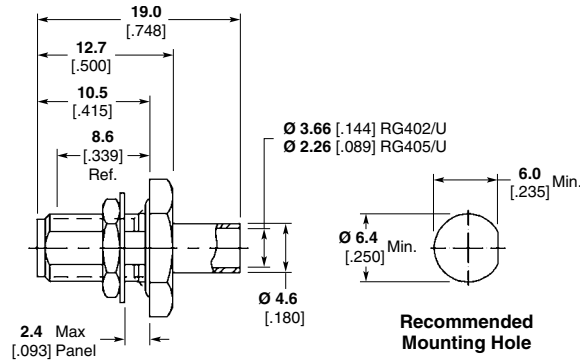

Cable Type RG/U	Body Material & Finish	Contact Captivation	Contact Attachment	Solder Assembly Kit Part No.	Instruction Sheet	Part No.
402 (3.58 [.141])	Brass, Gold	No	Solder	1055420-1	408-4768	1082029-1

**2 Hole Flange Mount
Cable Jack**

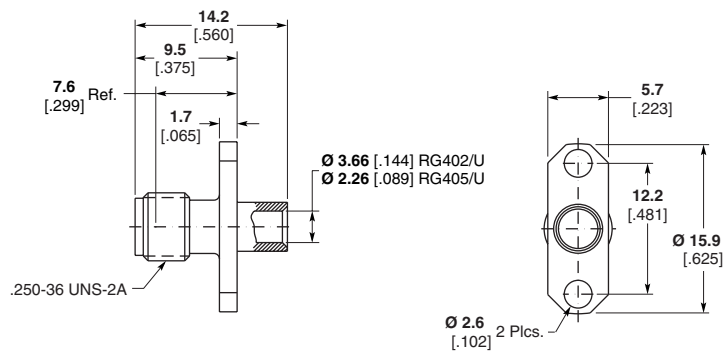

Cable Type RG/U	Body Material & Finish	Contact Captivation	Contact Attachment	Solder Assembly Kit Part No.	Instruction Sheet	Part No.
402 (3.58 [.141])	Stainless, Gold	No	Solder	1055420-1	408-4767	1051052-1
405 (2.16 [.085])	Stainless, Gold	No	Solder	1055420-1	408-4883	1051046-1

**4 Hole Flange Mount
Cable Jack**

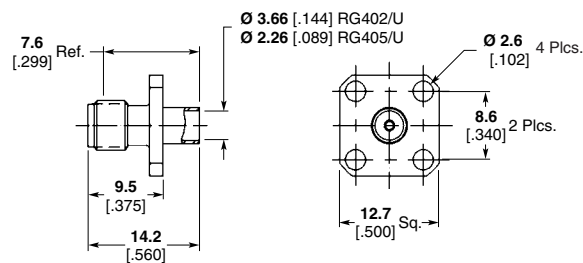

Cable Type RG/U	Body Material & Finish	Contact Captivation	Contact Attachment	Solder Assembly Kit Part No.	Instruction Sheet	Part No.
402 (3.58 [.141])	Stainless, Gold	No	Solder	1055420-1	408-4767	1051081-1
405 (2.16 [.085])	Stainless, Gold	No	Solder	1055420-1	408-4883	1051085-1

Note: Part Numbers are RoHS compliant except: ♦ Indicates non-RoHS compliant.

SMA Connectors (Continued)
Semi-Rigid Cable

**Right-Angle Cable Plug,
Direct Solder Attachment**

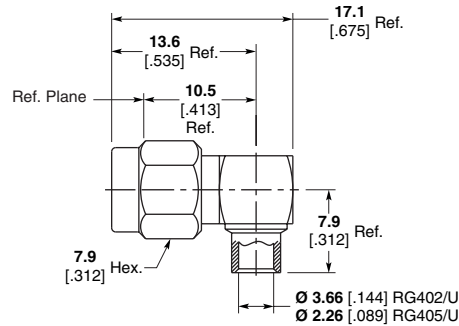

Cable Type RG/U	Body Material & Finish	Contact Captivation	Contact Attachment	Solder Assembly Kit Part No.	Instruction Sheet	Part No.
402 (3.58 [0.141])	Stainless, Gold ¹	Epoxy	Solder	1055420-1	408-4831	1051151-1
405 (2.16 [0.085])	Stainless, Gold ¹	Epoxy	Solder	1055420-1	408-4831	1051157-1
405 (2.16 [0.085])	Brass, Gold	Mechanical	Solder	1055420-1	408-4831	1088312-1

¹Coupling nut is passivated stainless steel.

Straight Cable Plug, Crimp

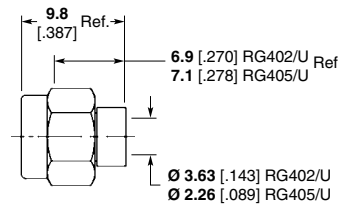

Cable Type RG/U	Body Material & Finish	Contact Captivation	Contact Attachment	Crimp Tooling Part No.	Instruction Sheet	Part No.
405 (2.16 [0.085])	Stainless, Pass.	Mechanical	Solderless	1055835-1	408-4695	1050598-1
402 (3.58 [0.141])	Stainless, Pass.	No Center Contact	Solderless	1055835-1	408-4690	1050740-1

**Straight Cable Plug —
Low Profile, Crimp**

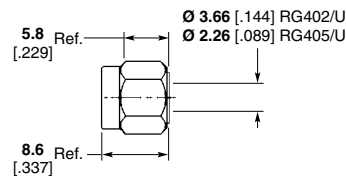

Cable Type RG/U	Body Material & Finish	Contact Captivation	Contact Attachment	Crimp Tooling Part No.	Instruction Sheet	Part No.
402 (3.58 [0.141])	Stainless, Pass.	Mechanical	Solderless	1055835-1	408-4696	1050602-1
405 (2.16 [0.085])	Stainless, Pass.	Mechanical	Solderless	1055835-1	408-4697	1050611-1

Note: Part Numbers are RoHS compliant except: ♦ Indicates non-RoHS compliant.

SMA Connectors (Continued)
Semi-Rigid Cable (Continued)

2 Hole Flange, Crimp

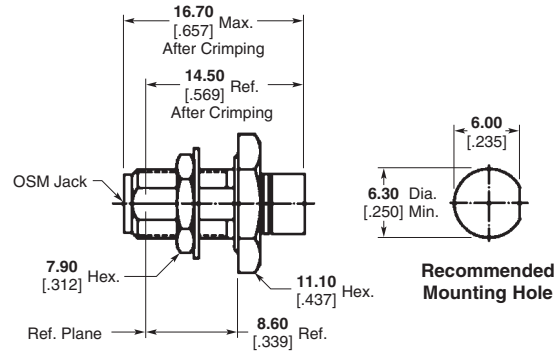

Cable Type RG/U	Body Material & Finish	Contact Captivation	Contact Attachment	Crimp Tooling Part No.	Instruction Sheet	Part No.
402 (3.58 [.141])	Stainless, Pass.	Mechanical	Solderless	1055835-1	408-4954	1051005-1
405 (2.16 [.085])	Stainless, Pass.	Mechanical	Solderless	1055835-1	408-4689	1051007-1

Right-Angle Cable Plug, Crimp

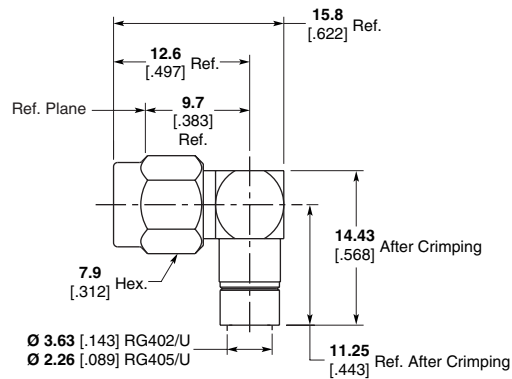

Cable Type RG/U	Body Material & Finish	Contact Captivation	Contact Attachment	Crimp Tooling Part No.	Instruction Sheet	Part No.
402 (3.58 [.141])	Stainless, Pass.	Mechanical	Solderless	1055835-1	408-4691	1051145-1
405 (2.16 [.085])	Stainless, Pass.	Mechanical	Solderless	1055835-1	408-4692	1051147-1

Note: Part Numbers are RoHS compliant except: ♦ Indicates non-RoHS compliant.

SMA Connectors (Continued)
Panel Mount, Solder Pot Terminal

4 Hole Flange Mount Plug Receptacle

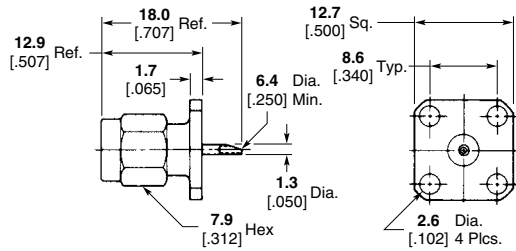

Body Material & Finish	Contact Captivation	RF Leakage db min.	Temperature Range	Part No.
Stainless, Passivated	Epoxy	N/A	-65 to 125° C	1052324-1

4 Hole Flange Mount Jack Receptacle

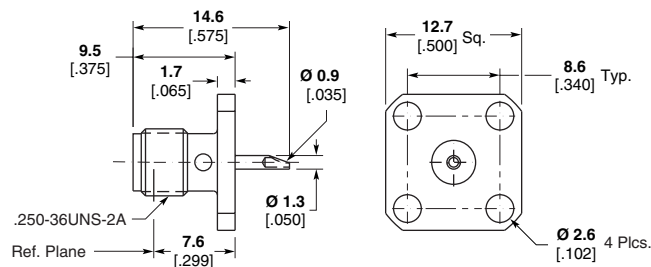

Body Material & Finish	Contact Captivation	RF Leakage db min.	Temperature Range	Part No.
Stainless, Passivated	Epoxy	-(60-fGHz)	-65 to 125° C	1052422-1

2 Hole Flange Mount Jack Receptacle

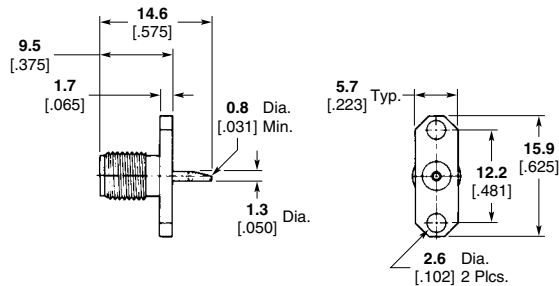

Body Material & Finish	Contact Captivation	RF Leakage db min.	Temperature Range	Part No.
Stainless, Passivated	Epoxy	-(60-fGHz)	-65 to 125° C	1052544-1

2 Hole Flange Mount Jack Receptacle

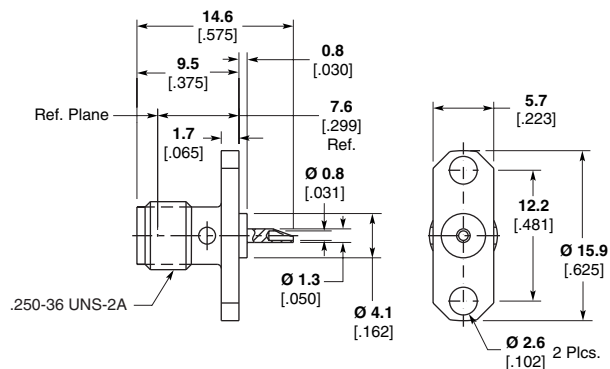

Body Material & Finish	Contact Captivation	RF Leakage db min.	Temperature Range	Part No.
Stainless, Passivated	Epoxy	-(60-fGHz)	-65 to 125° C	1052534-1

Note: Part Numbers are RoHS compliant except: ♦ Indicates non-RoHS compliant.

SMA Connectors (Continued)
Panel Mount

Bulkhead Feedthrough Jack Receptacle, Solder Pot Terminal

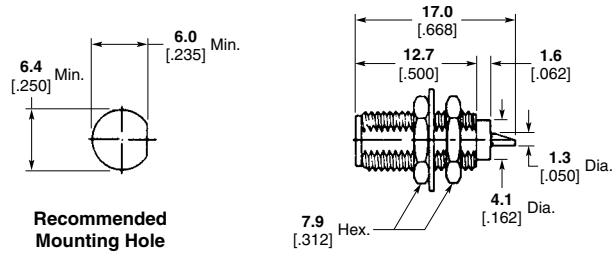

Recommended Mounting Hole

Body Material & Finish	Contact Captivation	RF Leakage db min.	Temperature Range	Part No.
Stainless, Passivated	Epoxy	N/A	-65 to 125° C	1053092-1

Press-In Jacks, Straight Terminal

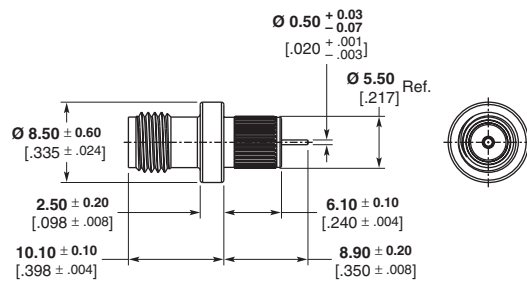

Part Number 1460468

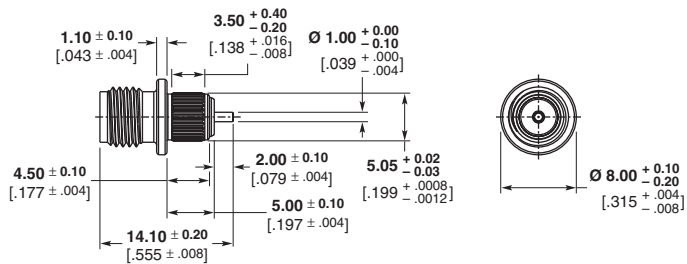

Part Number 1460469

Body Material & Finish	Contact Captivation	RF Leakage db min.	Temperature Range	Part No.
Brass, White Bronze	Mechanical	N/A	-65 to 125° C	1460468-1
Brass, Gold	Mechanical	N/A	-65 to 125° C	1460469-1

Press-In Cable, Jack Panel

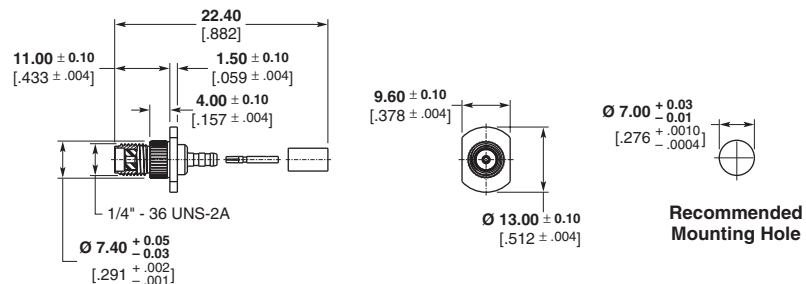

Recommended Mounting Hole

Note: Part Numbers are RoHS compliant except: ♦ Indicates non-RoHS compliant.

Cable Type RG/U	Body Material & Finish	Contact Captivation	Temperature Range	Part No.
316 D	Brass, Gold	Mechanical	-65 to 125° C	619115-1

SMA Connectors (Continued)
Panel Mount, Straight Terminal

4 Hole Flange Mount Jack Receptacle

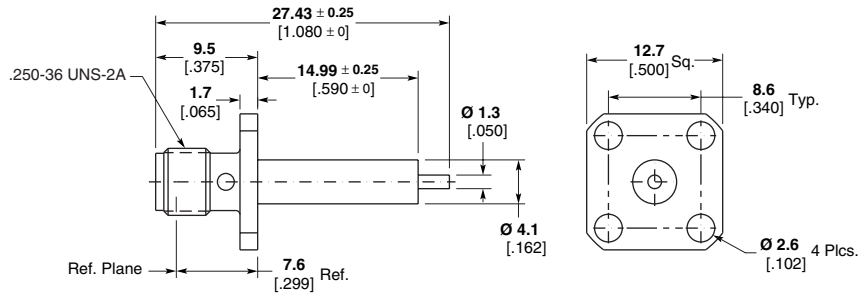

Body Material & Finish	Contact Captivation	RF Leakage db min.	Temperature Range	Part No.
Stainless, Passivated	None	-(100-fGHz)	-65 to 165° C	1052518-1
Stainless, Passivated	Epoxy	-(60-fGHz)	-65 to 125° C	1052523-1
Stainless, Gold	Epoxy	-(60-fGHz)	-65 to 125° C	1052522-1

2 Hole Flange Mount Plug Receptacle

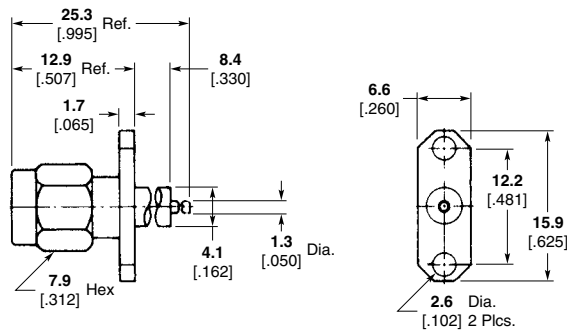

Body Material & Finish	Contact Captivation	RF Leakage db min.	Temperature Range	Part No.
Stainless, Passivated	Epoxy	-(60-fGHz)	-65 to 125° C	1052349-1

2 Hole Flange Mount Jack Receptacle

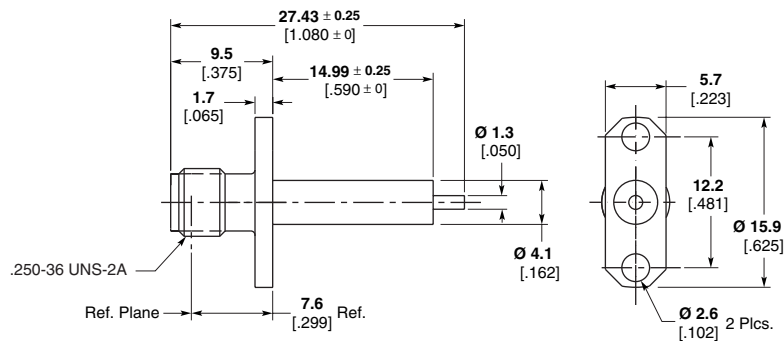

Body Material & Finish	Contact Captivation	RF Leakage db min.	Temperature Range	Part No.
Stainless, Passivated	Epoxy	-(60-fGHz)	-65 to 125° C	1052552-1

Note: Part Numbers are RoHS compliant except: ♦ Indicates non-RoHS compliant.

SMA Connectors (Continued)
Panel Mount, Straight Terminal (Continued)

Bulkhead Feedthrough Jack Receptacle

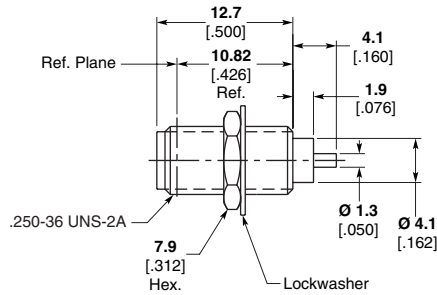

Body Material & Finish	Contact Captivation	RF Leakage db min.	Temperature Range	Part No.
Stainless, Passivated	Epoxy	-(60-fGHz)	-65 to 125° C	1053222-1

2 Hole Flange Mount Right-Angle Jack Receptacle

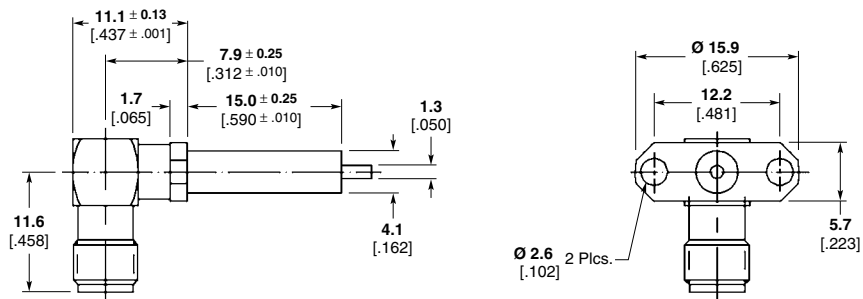

Body Material & Finish	Contact Captivation	RF Leakage db min.	Temperature Range	Part No.
Stainless, Passivated	Mechanical	-(90-fGHz)	-65 to 165° C	1052986-1

4 Hole Flange Mount Right-Angle Jack Receptacle

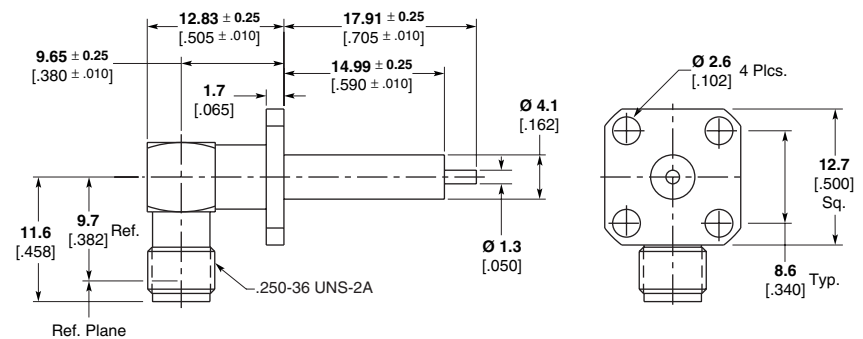

Body Material & Finish	Contact Captivation	RF Leakage db min.	Temperature Range	Part No.
Stainless, Passivated	Mechanical	-(90-fGHz)	-65 to 165° C	1052978-1
Stainless, Passivated	Mechanical	-(90-fGHz)	-65 to 165° C	1052982-1

Note: Part Numbers are RoHS compliant except: ♦ Indicates non-RoHS compliant.

SMA Connectors (Continued)
Panel Mount

4 Hole Flange Mount Jack Receptacle, Straight Terminal

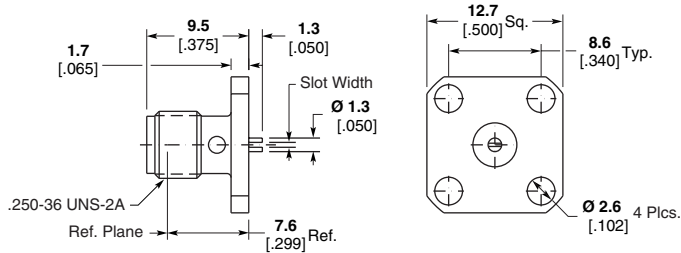

Body Material & Finish	Contact Captivation	Slot Width +.076/- .025 [+.003/- .001]	RF Leakage db min.	Temperature Range	Part No.
Stainless, Passivated	Epoxy	0.5 [.018]	-(60-fGHz)	-65 to 125° C	1052563-1

4 Hole Flange Mount Plug Receptacle, Tab Terminal

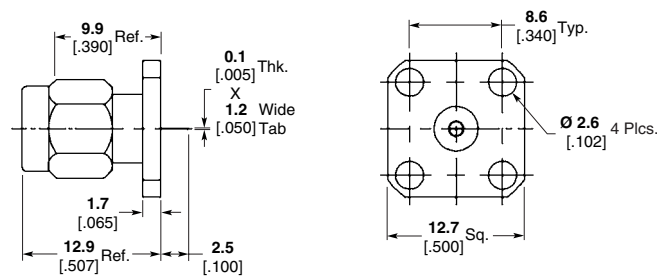

Body Material & Finish	Contact Captivation	Tab Width	RF Leakage db min.	Temperature Range	Part No.
Stainless, Passivated	Epoxy	1.3 [.050]	-(60-fGHz)	-65 to 125° C	1052360-1

4 Hole Flange Mount Jack Receptacle, Tab Terminal

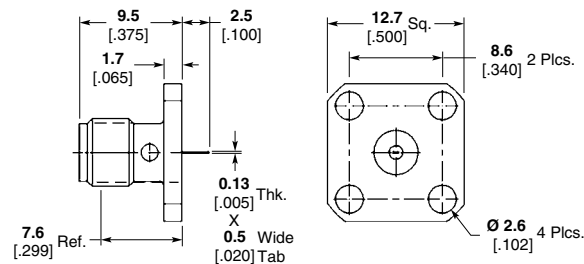

Body Material & Finish	Contact Captivation	Tab Width	RF Leakage db min.	Temperature Range	Part No.
Stainless, Passivated	Epoxy	.51 [.020]	-(60-fGHz)	-65 to 125° C	1052898-1

Note: Part Numbers are RoHS compliant except: ♦ Indicates non-RoHS compliant.

SMA Connectors (Continued)

2 Hole Flange Mount Jack Receptacle, Panel Mount, Tab Terminal

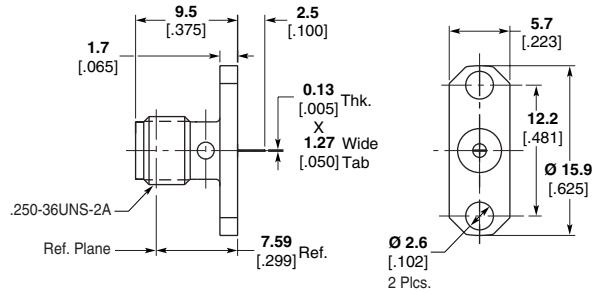

Body Material & Finish	Contact Captivation	Horizontal Tab	RF Leakage db min.	Temperature Range	Part No.
Stainless, Passivated	Epoxy	↙	-(60-fGHz)	-65 to 125° C	1052577-1

4 Hole Flange Mount Jack Receptacle, for Microstrip Transmission Line Circuits

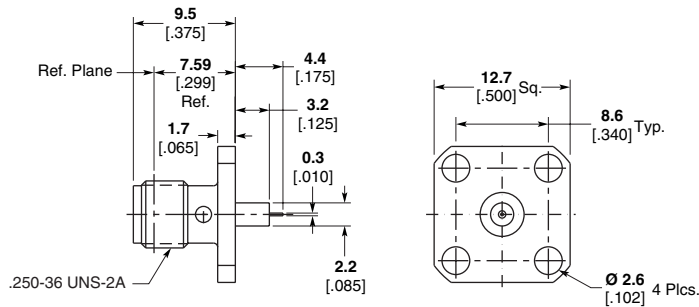

Body Material & Finish	Contact Captivation	RF Leakage db min.	Temperature Range	Part No.
Stainless, Passivated	Epoxy	-(60-fGHz)	-65 to 125° C	1052528-1

2 Hole Flange Mount Jack Receptacle, for Microstrip Transmission Line Circuits

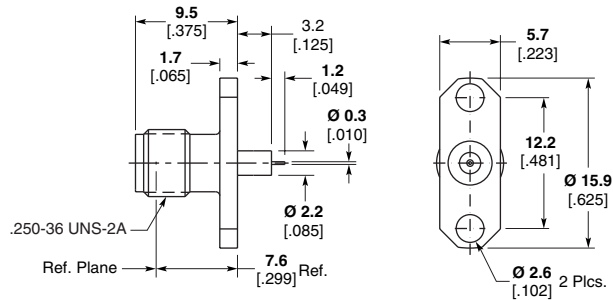

Body Material & Finish	Contact Captivation	RF Leakage db min.	Temperature Range	Part No.
Stainless, Passivated	Epoxy	-(60-fGHz)	-65 to 125° C	1052902-1

Note: Part Numbers are RoHS compliant except: ♦ Indicates non-RoHS compliant.

SMA Connectors (Continued)
Field Replaceable Hermetic Launchers (Continued)

4 Hole Flange Mount Jack Receptacle with EMI/RFI Gasket

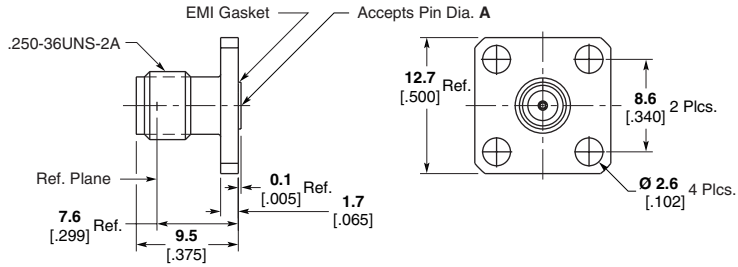

Material & Finish	Captivation	Pin Diameter A	Part No.
Stainless, Passivated	Mechanical	.38 [0.015]	1052684-1

4 Hole Flange Mount Jack Receptacle without EMI/RFI Gasket

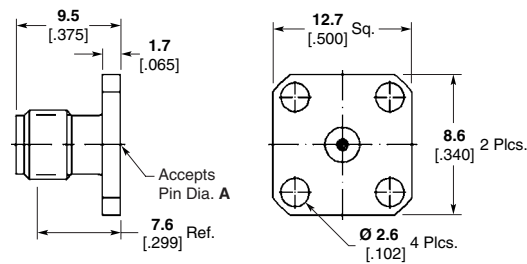

Material & Finish	Captivation	Pin Diameter A	Part No.
Stainless, Passivated	Mechanical	.91 [0.036]	1052643-1

2 Hole Flange Mount Jack Receptacle with EMI/RFI Gasket

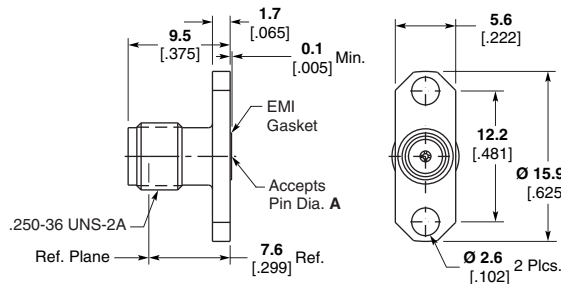

Material & Finish	Captivation	Pin Diameter A	Part No.
Stainless, Passivated	Mechanical	.30 [0.012]	1052628-1
Stainless, Passivated	Mechanical	.38 [0.015]	1052689-1
Stainless, Passivated	Mechanical	.46 [0.018]	1052634-1

2 Hole Flange Mount Jack Receptacle without EMI/RFI Gasket, Field Replaceable Hermetic Launchers

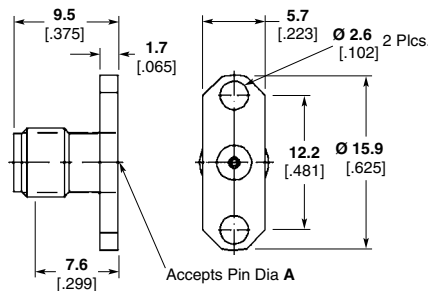

Material & Finish	Captivation	Pin Diameter A	Part No.
Stainless, Passivated	Mechanical	.51 [0.020]	1052652-1
Stainless, Passivated	Mechanical	.91 [0.036]	1052646-1

Note: Part Numbers are RoHS compliant except: ♦ Indicates non-RoHS compliant.

SMA Connectors (Continued)

**In-Series Adapter,
Jack to Jack**

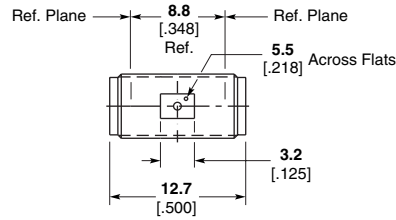

Frequency	Material & Finish	Captivation	Part No.
DC-18.0GHz	Stainless, Gold	Epoxy*	1053488-1

**In-Series Adapter,
Plug to Plug**

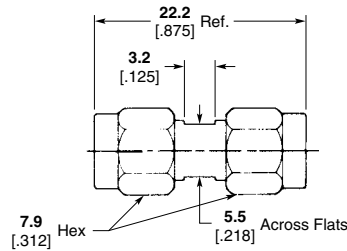

Frequency	Material & Finish	Captivation	Part No.
DC-18.0GHz	Stainless, Passivated	Epoxy*	1053635-1

*All adapters listed above employ epoxy captivation. Mechanically captivated versions are also available. Please consult Tyco Electronics.

**In-Series Adapter,
Jack to Plug, Right-Angle**

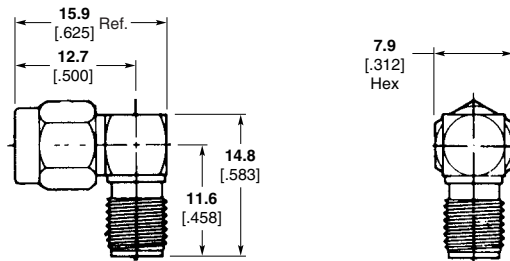

Frequency	Material & Finish	Captivation	Part No.
DC-12.4GHz	Stainless, Passivated	Mechanical	1055065-1

**In-Series Adapter,
Jack to Jack, Right-Angle**

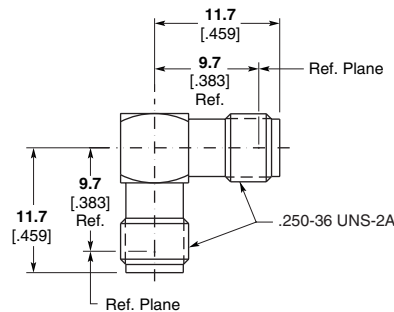

Frequency	Material & Finish	Captivation	Part No.
DC-12.4GHz	Stainless, Passivated	Mechanical	1055018-1

Note: Part Numbers are RoHS compliant except: ♦ Indicates non-RoHS compliant.

SMA Connectors (Continued)

**In-Series Adapter,
Plug to Plug, Right-Angle**

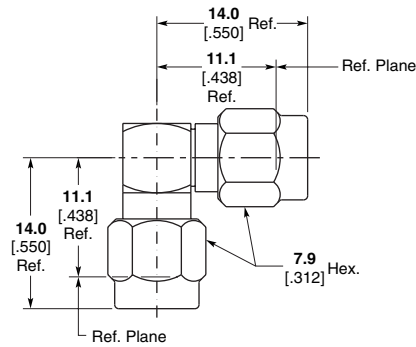

Frequency	Material & Finish	Captivation	Part No.
DC-18.0GHz	Stainless, Passivated	Mechanical	1055047-1

**In-Series Adapter,
Jack to Plug, Connector Saver**

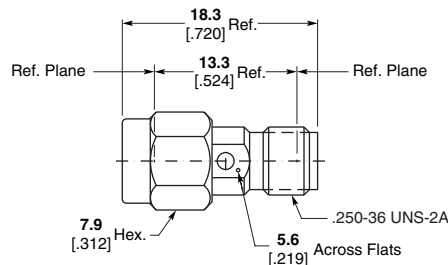

Frequency	Material & Finish	Captivation	Part No.
DC-18.0GHz	Stainless, Passivated	Epoxy	1054426-1

**In-Series Adapter,
Jack to Jack,
Bulkhead Feedthrough**

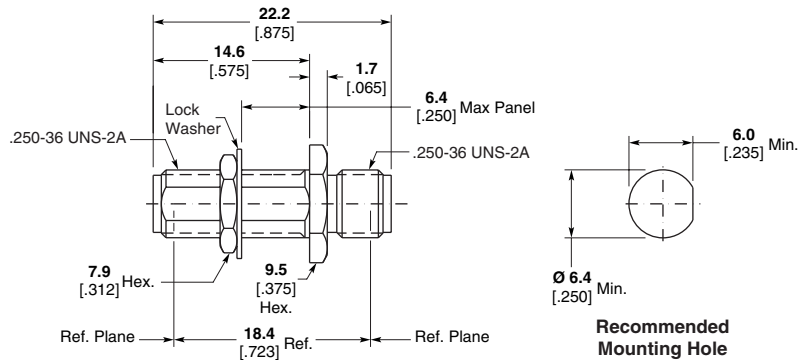

Frequency	Material & Finish	Captivation	Part No.
DC-18.0GHz	Stainless, Passivated	Epoxy*	1054869-1

*Mechanically captivated version available. Please consult Tyco Electronics.

**Test Adapter,
Plug to Jack,
Quick Release**

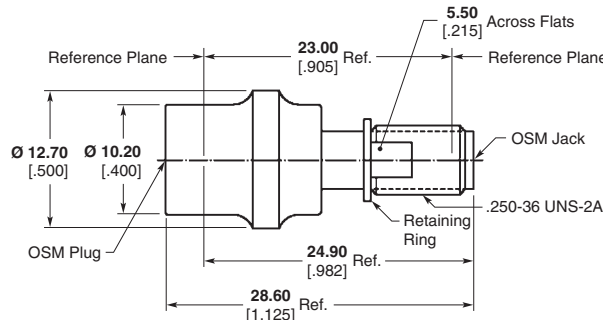

Frequency	Material & Finish	Captivation	Part No.
DC-18.0GHz	Stainless, Passivated	Epoxy	1053780-1

Note: Part Numbers are RoHS compliant except: ♦ Indicates non-RoHS compliant.

Компания «Life Electronics» занимается поставками электронных компонентов импортного и отечественного производства от производителей и со складов крупных дистрибьюторов Европы, Америки и Азии.

С конца 2013 года компания активно расширяет линейку поставок компонентов по направлению коаксиальный кабель, кварцевые генераторы и конденсаторы (керамические, пленочные, электролитические), за счёт заключения дистрибьюторских договоров

Мы предлагаем:

- Конкурентоспособные цены и скидки постоянным клиентам.
- Специальные условия для постоянных клиентов.
- Подбор аналогов.
- Поставку компонентов в любых объемах, удовлетворяющих вашим потребностям.
- Приемлемые сроки поставки, возможна ускоренная поставка.
- Доставку товара в любую точку России и стран СНГ.
- Комплексную поставку.
- Работу по проектам и поставку образцов.
- Формирование склада под заказчика.
- Сертификаты соответствия на поставляемую продукцию (по желанию клиента).
- Тестирование поставляемой продукции.
- Поставку компонентов, требующих военную и космическую приемку.
- Входной контроль качества.
- Наличие сертификата ISO.

В составе нашей компании организован Конструкторский отдел, призванный помогать разработчикам, и инженерам.

Конструкторский отдел помогает осуществить:

- Регистрацию проекта у производителя компонентов.
- Техническую поддержку проекта.
- Защиту от снятия компонента с производства.
- Оценку стоимости проекта по компонентам.
- Изготовление тестовой платы монтаж и пусконаладочные работы.



Тел: +7 (812) 336 43 04 (многоканальный)

Email: org@lifeelectronics.ru