



Package Style: QFN, 20-Pin, 3.5mmx3.5mmx0.5mm



Features

- Tx Output Power=22 dBm
- Integrated RF Front End Module with TX/RX switch, PA, filter, and DP2T switch.
- 50Ω single-ended bidirectional Transceiver interface.

Applications

- ZigBee® 802.15.4 Based Systems for Remote Monitoring and Control
- WiFi 802.11b/g
- 2.4GHz ISM band applications
- Smart Meters for Energy Management

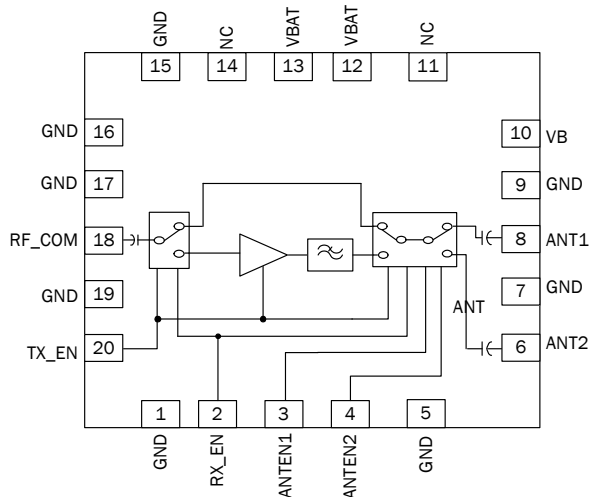

Functional Block Diagram

Product Description

The RF6545 integrates a complete solution in a single Front End Module (FEM) for WiFi and ZigBee® applications in the 2.4GHz to 2.5GHz band. This FEM integrates the PA plus harmonic filter in the transmit path. It provides a single balanced TDD access for Rx and Tx paths along with two ports on the output for connecting a diversity solution or a test port. The device is provided in a 3.5mm x 3.5mm x 0.5mm, 20 pin QFN package.

Ordering Information

RF6545SQ	Standard 25 piece bag
RF6545SR	Standard 100 piece reel
RF6545TR7	Standard 750 piece reel
RF6545TR13	Standard 2500 piece reel
RF6545PCK-410	Fully assembled evaluation board and 5 loose pieces

Optimum Technology Matching® Applied

- | | | | |
|-----------------------------------------------|--------------------------------------|------------------------------------------------|------------------------------------|
| <input type="checkbox"/> GaAs HBT | <input type="checkbox"/> SiGe BiCMOS | <input checked="" type="checkbox"/> GaAs pHEMT | <input type="checkbox"/> GaN HEMT |
| <input type="checkbox"/> GaAs MESFET | <input type="checkbox"/> Si BiCMOS | <input type="checkbox"/> Si CMOS | <input type="checkbox"/> BIFET HBT |
| <input checked="" type="checkbox"/> InGaP HBT | <input type="checkbox"/> SiGe HBT | <input type="checkbox"/> Si BJT | <input type="checkbox"/> LDMOS |

RF MICRO DEVICES®, RFMD®, Optimum Technology Matching®, Enabling Wireless Connectivity™, PowerStar®, POLARIS™ TOTAL RADIO™ and UltimateBlue™ are trademarks of RFMD, LLC. BLUETOOTH is a trademark owned by Bluetooth SIG, Inc., U.S.A. and licensed for use by RFMD. All other trade names, trademarks and registered trademarks are the property of their respective owners. ©2006, RF Micro Devices, Inc.

Absolute Maximum Ratings

Parameter	Rating	Unit
DC Supply Voltage	5.0	V
DC Supply Current	300	mA
Operating Case Temperature	-40 to +85	°C
Storage Temperature	-40 to +150	°C
ESD Human Body Model RF Pins	1000	V
ESD Human Body Model All Other Pins	500	V
ESD Charge Device Model All Pins	500	V
Moisture Sensitivity Level	MSL 2	
Maximum Input Power to PA	+10	dBm



Caution! ESD sensitive device.

Exceeding any one or a combination of the Absolute Maximum Rating conditions may cause permanent damage to the device. Extended application of Absolute Maximum Rating conditions to the device may reduce device reliability. Specified typical performance or functional operation of the device under Absolute Maximum Rating conditions is not implied.

The information in this publication is believed to be accurate and reliable. However, no responsibility is assumed by RF Micro Devices, Inc. ("RFMD") for its use, nor for any infringement of patents, or other rights of third parties, resulting from its use. No license is granted by implication or otherwise under any patent or patent rights of RFMD. RFMD reserves the right to change component circuitry, recommended application circuitry and specifications at any time without prior notice.



RFMD Green: RoHS compliant per EU Directive 2002/95/EC, halogen free per IEC 61249-2-21, < 1000ppm each of antimony trioxide in polymeric materials and red phosphorus as a flame retardant, and <2% antimony in solder.

Parameter	Specification			Unit	Condition
	Min.	Typ.	Max.		
Overall					Specifications must be met across supply voltage, control voltage, and temperature ranges unless otherwise specified.
V _{BATT}	3.0	3.3	3.6	V _{DC}	
Operating Temperature Range	-40	+25	+85	°C	
Z ₀		50		Ω	
Off Mode Current		1		μA	All logic low; V _{LOW} ≤ 0.1V
TX Path					
Frequency	2400		2483	MHz	
Input Return Loss	12			dB	
Output Return Loss	10			dB	
Transmit Path Gain	25	28		dB	
Gain Flatness	-0.8		+0.8	dB	
Rated Output Power		22		dBm	Nominal conditions
	20			dBm	
Supply Current		200		mA	P _O = 22 dBm 802.15.4 OQPSK
		170		mA	P _O = 20 dBm 802.15.4 OQPSK
Thermal Resistance		66		°C/W	V _{CC} = 3.6V, P _{OUT} = 22dBm, T _{REF} = 85 °C
2nd harmonic level			-42	dBm/MHz	P _O = 20 dBm
3rd harmonic level			-42	dBm/MHz	P _O = 20 dBm; V _{CC} ≥ 3.3V
VSWR Stability and Load	4:1				
VSWR No Damage	8:1				
Gain Settling Time		1	2	μS	

Parameter	Specification			Unit	Condition
	Min.	Typ.	Max.		
RX Path					
Frequency	2400		2483	MHz	
Insertion Loss/Noise Figure		1.5	2.0	dB	
Gain Flatness	-0.5		+0.5	dB	
Input Return Loss	12	15		dB	
Output Return Loss	12			dB	
Antenna Switch					
RF-to-Control Isolation	50			dB	
RF-to-ANT Isolation	17	20		dB	
RF-to-RF Isolation	18	20		dB	
T/R Switching Time			1	μs	
Logic Level "HIGH" Input Voltage	$V_{CC}-0.3$		$=V_{CC}$	V	
Logic Level "LOW" Input Voltage	0.0		+0.2	V	
Input Source Current at Logic "HIGH"		2		uA	
Switch Leakage Current at Logic "LOW"		0.1		uA	

Control Logic

Switch Control Logic	TX_EN	RX_EN	ANT1_EN	ANT2_EN
Tx, Antenna 1	High	Low	High	Low
Tx, Antenna 2	High	Low	Low	High
Rx, Antenna 1	Low	High	High	Low
Rx, Antenna 2	Low	High	Low	High
All Off	Low	Low	Low	Low

Pin	Function	Description
1	GND	Ground.
2	RX_EN	Enable voltage for the LNA and receive switch. See logic table for operation.
3	V ANT1	Control pin for Antenna 1 switch. See logic table for operation.
4	V ANT2	Control pin for Antenna 2 switch. See logic table for operation.
5	GND	Ground.
6	ANT2	This is a common port (antenna). It is matched to 50Ω and DC block is provided internally.
7	GND	Ground.
8	ANT1	This is a common port (antenna). It is matched to 50Ω and DC block is provided internally.
9	GND	Ground.
10	VCC	Voltage supply for PA 2nd stage. An external 1uF capacitor might be needed for low frequency decoupling.
11	N/C	No connect.
12	VCC	Voltage supply for PA 1st stage. An external 1uF capacitor might be needed for low frequency decoupling.
13	VCC	Voltage supply (control circuitry). An external 1uF capacitor might be needed for low frequency decoupling.
14	GND	Ground.
15	GND	Ground.
16	GND	Ground.
17	GND	Ground.
18	RF_COM	Bi-directional transmit/receive port for interfacing to TXVR SOIC. It is matched to 50Ω and DC block is provided internally.
19	GND	Ground.
20	TX_EN	Enable voltage for the PA and transmit switch. See logic table for operation.

Package Drawing

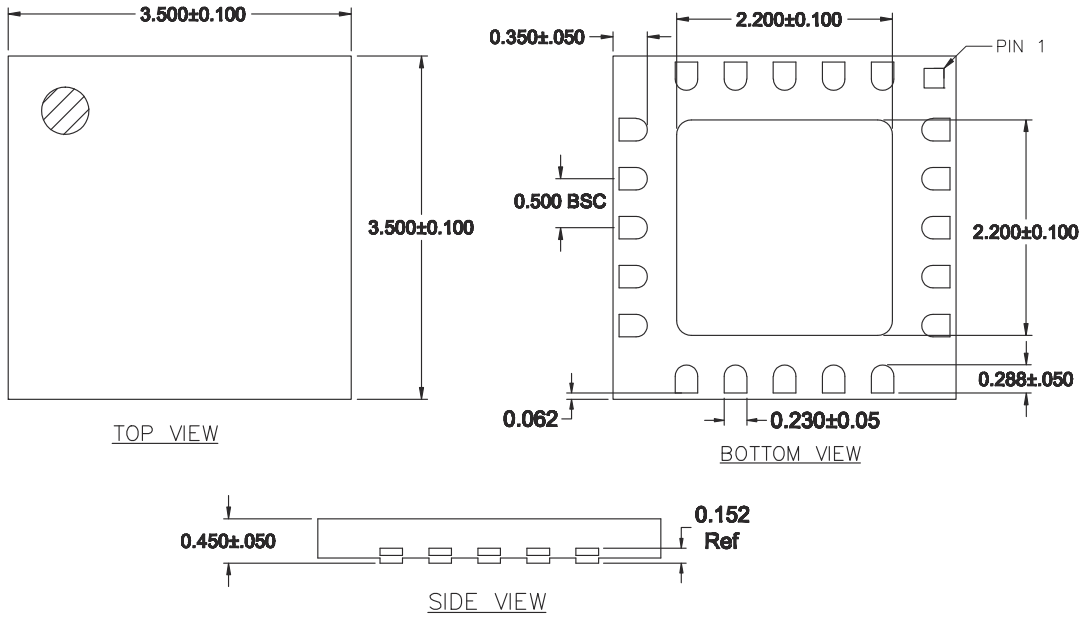

PCB Design Requirements

PCB Surface Finish

The PCB surface finish used for RFMD's qualification process is electroless nickel, immersion gold. Typical thickness is 3µinch to 8µinch gold over 180µinch nickel.

PCB Land Pattern Recommendation

PCB land patterns for RFMD components are based on IPC-7351 standards and RFMD empirical data. The pad pattern shown has been developed and tested for optimized assembly at RFMD. The PCB land pattern has been developed to accommodate lead and package tolerances. Since surface mount processes vary from company to company, careful process development is recommended.

PCB Metal Land and Solder Mask Pattern

A = 0.290 x 0.290 (mm) Typ Rounded Rectangle 60%
 B = 0.290 x 0.290 (mm) Typ Rounded Rectangle 50%
 C = 2.200 (mm) Sq Rounded Rectangle 5%

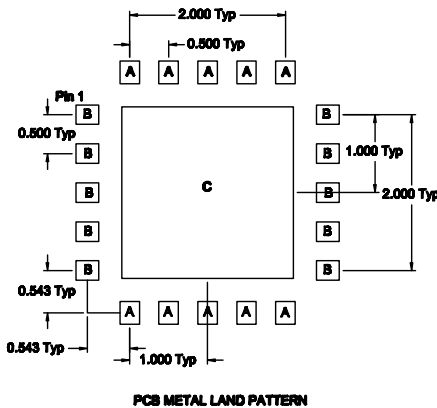

A = 0.360 x 0.430 (mm) Typ Rounded Rectangle 60%
 B = 0.430 x 0.360 (mm) Typ Rounded Rectangle 50%
 C = 2.340 (mm) Sq Rounded Rectangle 5%

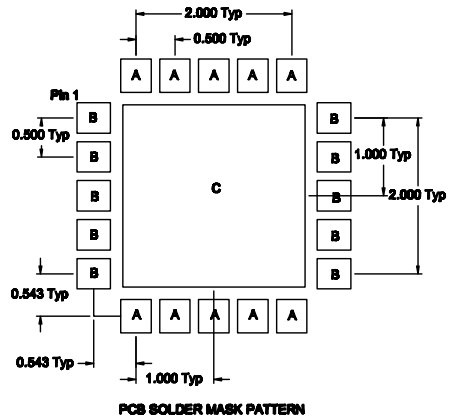

A = 0.225 x 0.261 (mm) Typ Rounded Rectangle 10%
 B = 0.261 x 0.225 (mm) Typ Rounded Rectangle 10%
 C = 0.900 (mm) Sq Typ Rounded Rectangle 10%

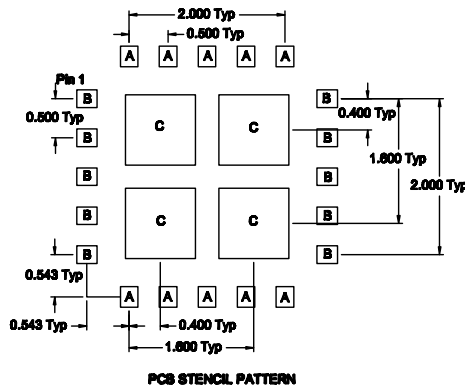

Thermal vias for center slug "C" should be incorporated into the PCB design. The number and size of thermal vias will depend on the application, the power dissipation, and this electrical requirements. Example of the number and size of vias can be found on the RFMD evaluation board layout.

RF6545 2.4 GHz Front End Module

Input Power versus Output Power

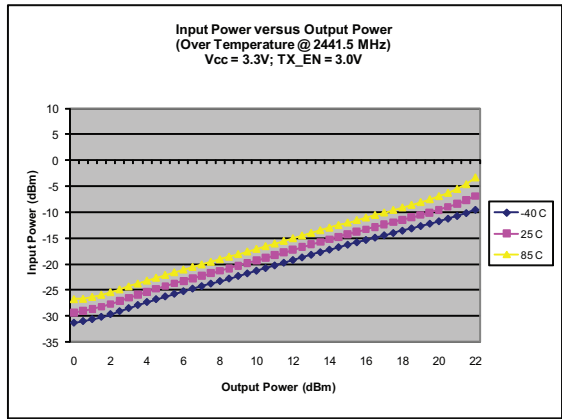
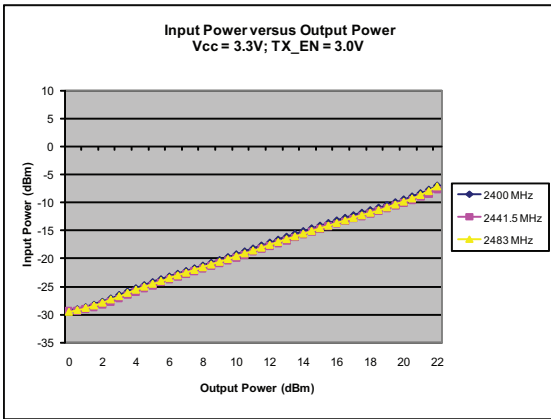

Gain versus Output Power

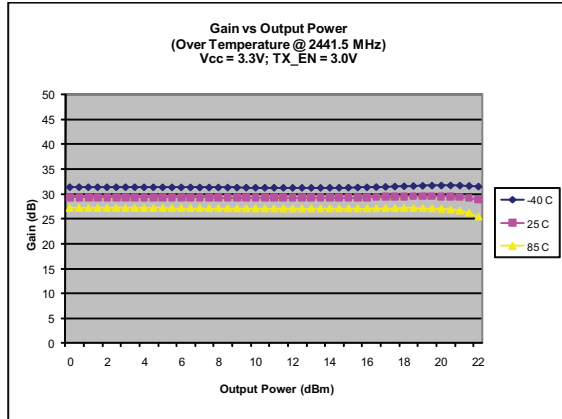
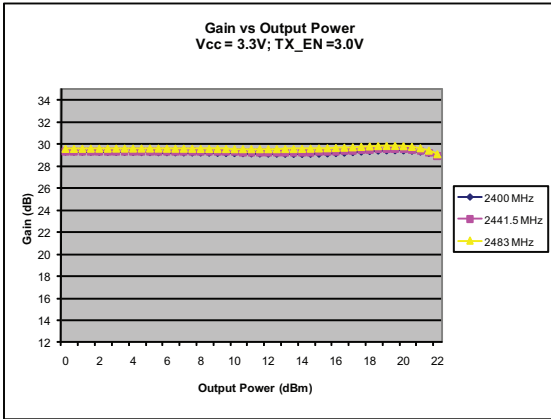

RF6545 2.4 GHz Front End Module
 Operating Current versus Output Power

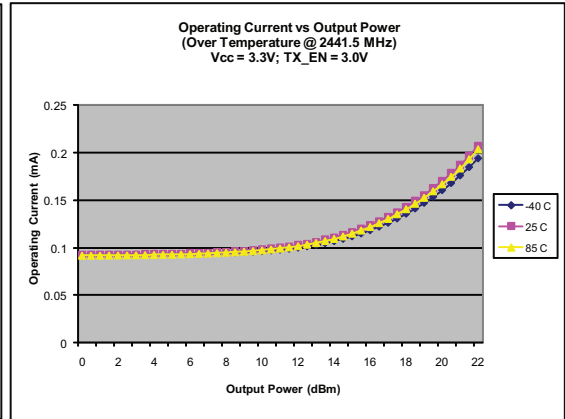
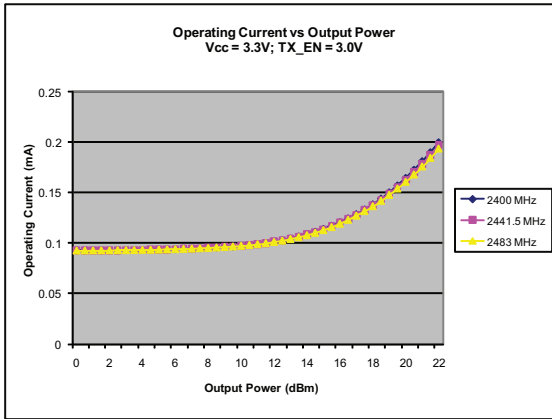

TX S21 versus Frequency

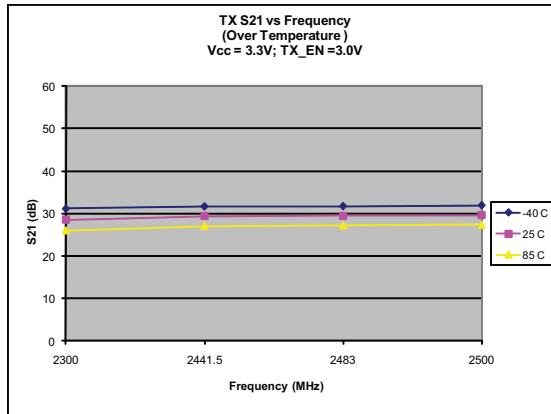

Компания «Life Electronics» занимается поставками электронных компонентов импортного и отечественного производства от производителей и со складов крупных дистрибьюторов Европы, Америки и Азии.

С конца 2013 года компания активно расширяет линейку поставок компонентов по направлению коаксиальный кабель, кварцевые генераторы и конденсаторы (керамические, пленочные, электролитические), за счёт заключения дистрибьюторских договоров

Мы предлагаем:

- Конкурентоспособные цены и скидки постоянным клиентам.
- Специальные условия для постоянных клиентов.
- Подбор аналогов.
- Поставку компонентов в любых объемах, удовлетворяющих вашим потребностям.
- Приемлемые сроки поставки, возможна ускоренная поставка.
- Доставку товара в любую точку России и стран СНГ.
- Комплексную поставку.
- Работу по проектам и поставку образцов.
- Формирование склада под заказчика.
- Сертификаты соответствия на поставляемую продукцию (по желанию клиента).
- Тестирование поставляемой продукции.
- Поставку компонентов, требующих военную и космическую приемку.
- Входной контроль качества.
- Наличие сертификата ISO.

В составе нашей компании организован Конструкторский отдел, призванный помогать разработчикам, и инженерам.

Конструкторский отдел помогает осуществить:

- Регистрацию проекта у производителя компонентов.
- Техническую поддержку проекта.
- Защиту от снятия компонента с производства.
- Оценку стоимости проекта по компонентам.
- Изготовление тестовой платы монтаж и пусконаладочные работы.



Тел: +7 (812) 336 43 04 (многоканальный)

Email: org@lifeelectronics.ru