

LEAD FREE CATALOGUE NUMBER

7712P0225A25LF

7312P0225A13LF



NOTES:

DESCRIPTION

Connector especially designed for SMT technology
EMV compatible and in accordance with ISO 7816-2

MECHANICAL

Contacts force : between 0.2N-0.5N
Durability : 100000 cycles
Insertion force : 10 N max
Extraction force : 1 N min

ELECTRICAL

Insulation resistance : 1000MOhms
Dielectric withstand voltage between card contacts and detection switch : 1000 Vrms
contact resistance:100 miliohms
Current carrying : min 10 micro A max 1A

SWITCH

Contact closed : contact resistance 100mOhms
Open contact : voltage proof 300Vms

MATERIAL

Contacts : copper alloy
Cover :
Color for LF part : Natural
Plating : Gold / Equivalent PdNi over Nickel on contact area
Solder tails : Sn bare edge allowed
Housing : self extinguishing, Thermoplastic
UL94-V0 rated

ENVIRONMENT

Storage temperature : -40°C, +85°C
Operating temperature : -20°C, +70°C
Packaging : Tray
Compatible reflow soldering process

NOTE: RoHS INFORMATIONS

-The "LF" products meet European Union Directives and other country regulations as described in GS-47-0004 .
- The housing will withstand exposure to 260°C peak temperature for 30 seconds in a convection, infra-red or vapor reflow oven. See Application notes/procedures, if they are available.
- Packaging spec: see GS-14-920

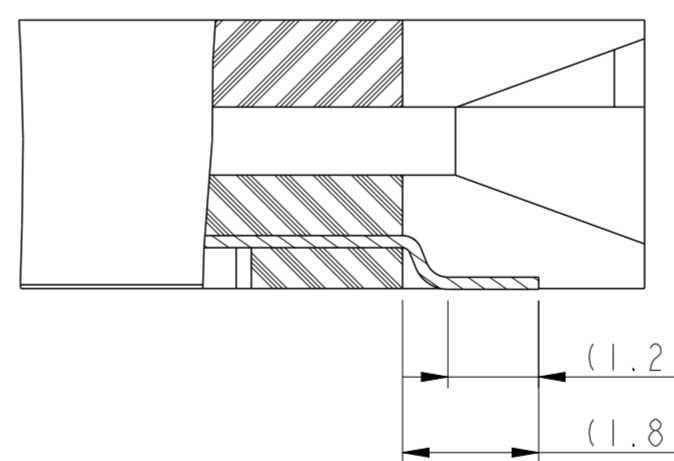
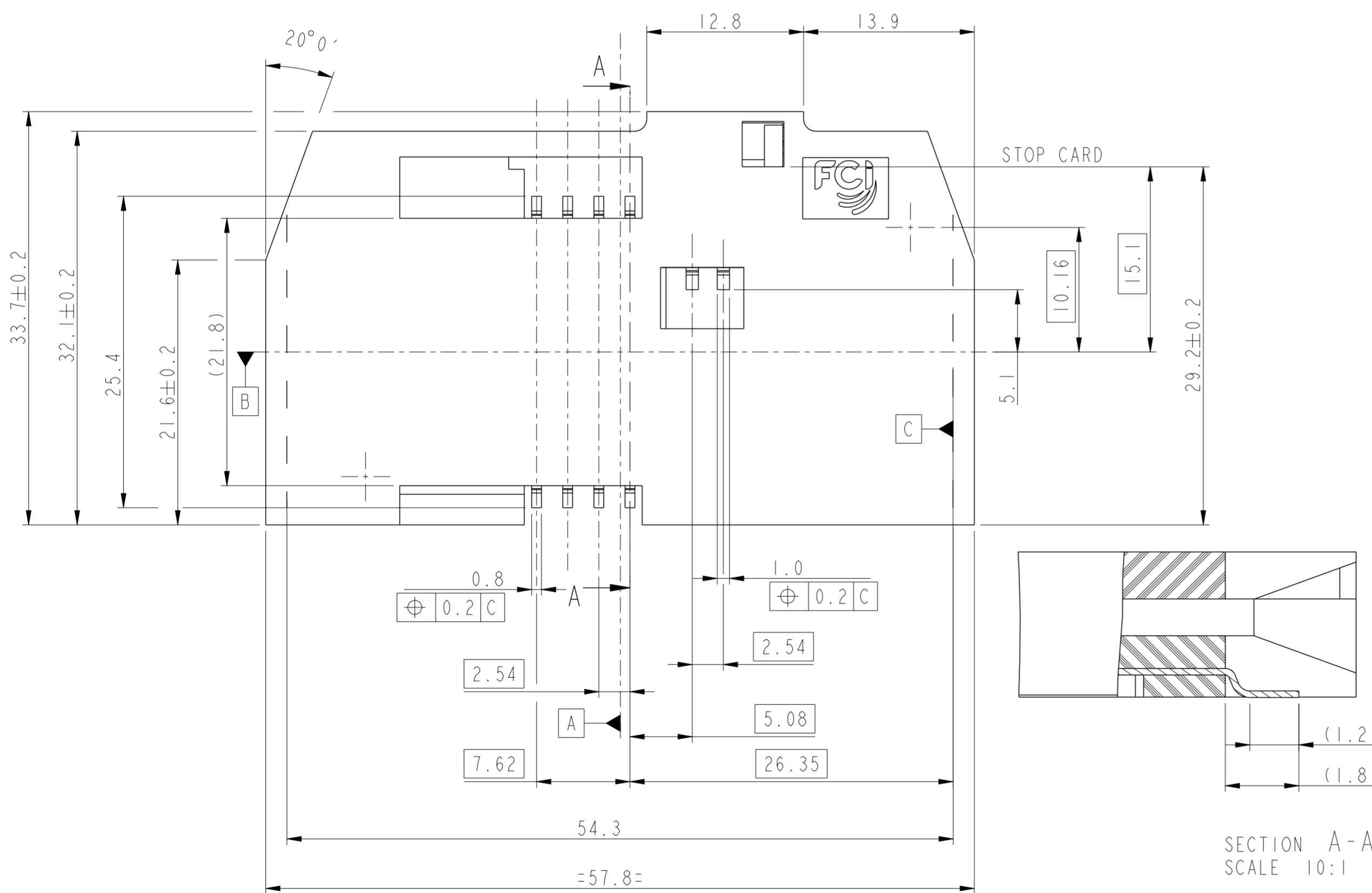
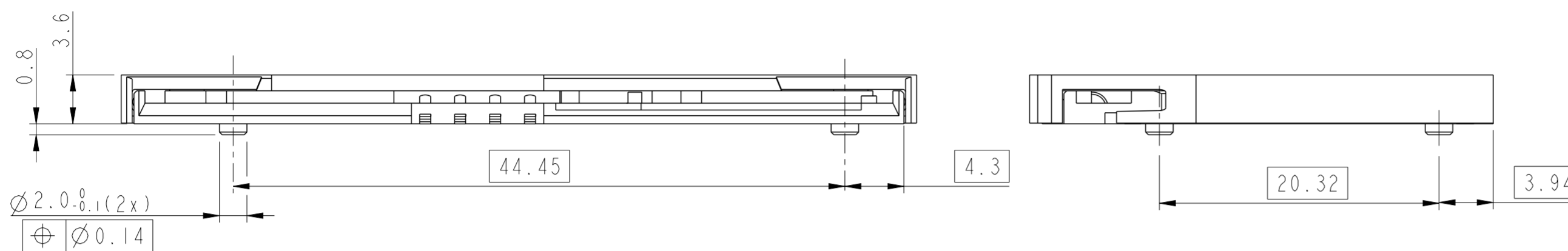

SECTION A-A
SCALE 10:1

Pick and place area

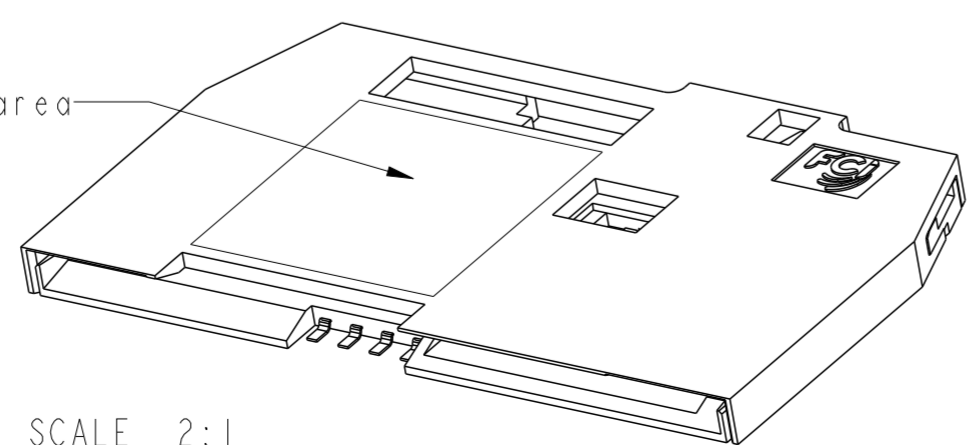

SCALE 2:1

spec ref	SEE NOTES	dr	P-Mathew Nebu	2014/09/27	projection	mm	size	A2	scale	3:1				
tolerance std	TOLERANCES UNLESS OTHERWISE SPECIFIED	eng	P-Mathew Nebu	2014/10/08		mm	ecn no	ELX-18989-1	rel level	Released				
ISO 406		chr	-											
ISO 1101		appr	K-Paul Biju	2014/10/08	product family	MOBILE I/O	cat. no.	VJW53666	rev	L				
surface	<table border="1"> <tr> <td>linear</td> <td>0.X</td> <td>±0.3</td> </tr> <tr> <td></td> <td>0.XX</td> <td>±0.1</td> </tr> <tr> <td></td> <td>0.XXX</td> <td>±0.05</td> </tr> </table>	linear	0.X	±0.3		0.XX	±0.1		0.XXX	±0.05		CHIP CARD CONNECTOR TYPE : P02 (8 cts with cover)		sheet 1 of 3
linear	0.X	±0.3												
	0.XX	±0.1												
	0.XXX	±0.05												
ISO 1302	angular 0° ±2°	www.fci.com	SEE TABLE	Product - Customer Drw										



Copyright FCI.

LEAD FREE CATALOGUE NUMBER
 7712P0225A25LF
 7312P0225A13LF

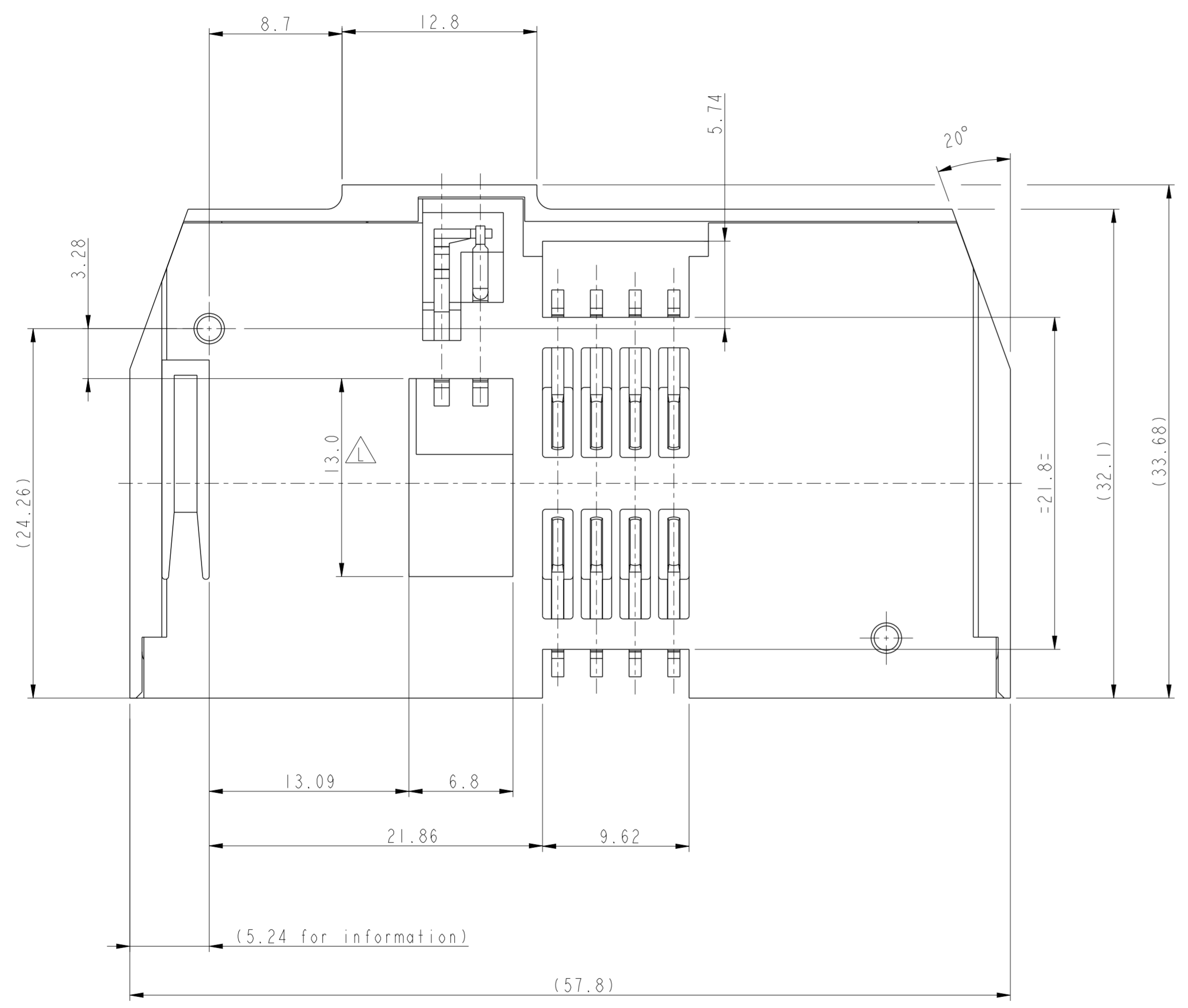

LAYOUT FOR KEEP OUT ZONE
 (CONNECTOR SIDE)

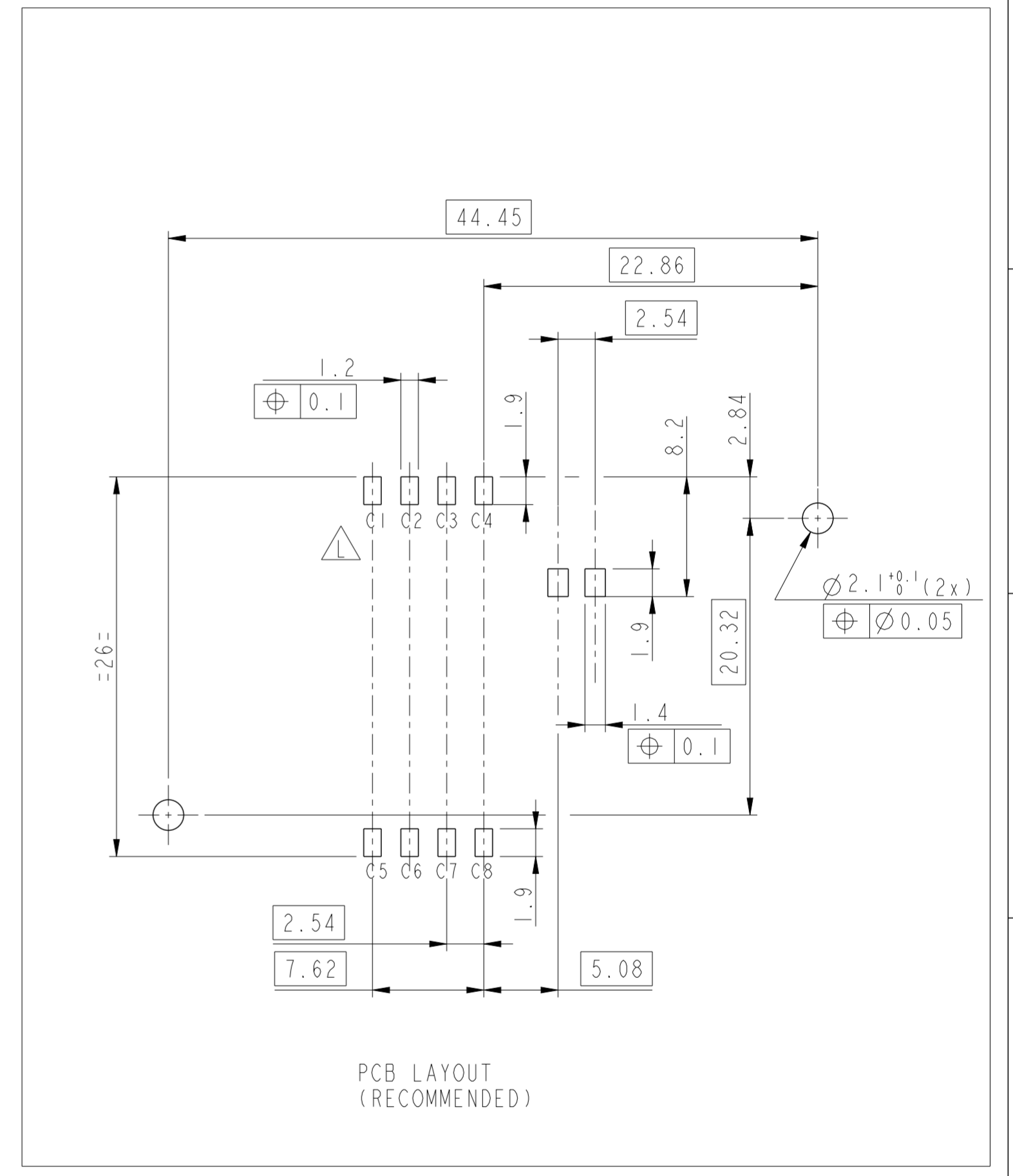

PCB LAYOUT
 (RECOMMENDED)

Copyright FCI.
FCI

spec ref	SEE NOTES	dr	P-Mathew Nebu	2014/09/27	projection	mm	size	A2	scale	4:1									
tolerance std	TOLERANCES UNLESS OTHERWISE SPECIFIED	eng	P-Mathew Nebu	2014/10/08		mm	ecn no	ELX-18989-1	rel level	Released									
ISO 406		chr	-																
ISO 1101		appr	K-Paul Biju	2014/10/08							product family	MOBILE I/O							
surface	<table border="1"> <tr> <td>linear</td> <td>0.X</td> <td>±0.3</td> </tr> <tr> <td></td> <td>0.XX</td> <td>±0.1</td> </tr> <tr> <td></td> <td>0.XXX</td> <td>±0.05</td> </tr> <tr> <td>angular</td> <td>0°</td> <td>±2°</td> </tr> </table>	linear	0.X	±0.3		0.XX	±0.1		0.XXX	±0.05	angular	0°	±2°		CHIP CARD CONNECTOR TYPE : P02 (8 cts with cover)		cat. no. SEE TABLE	Product - Customer Drw	sheet 2 of 3
linear	0.X	±0.3																	
	0.XX	±0.1																	
	0.XXX	±0.05																	
angular	0°	±2°																	
ISO 1302		www.fci.com	cat. no.	SEE TABLE	Product - Customer Drw	sheet 2 of 3													

PDS: Rev :L

STATUS:Released

Printed: Oct 08, 2014

7712P0225A25LF

FOR PICK AND PLACE VERSION

SEE DETAIL B

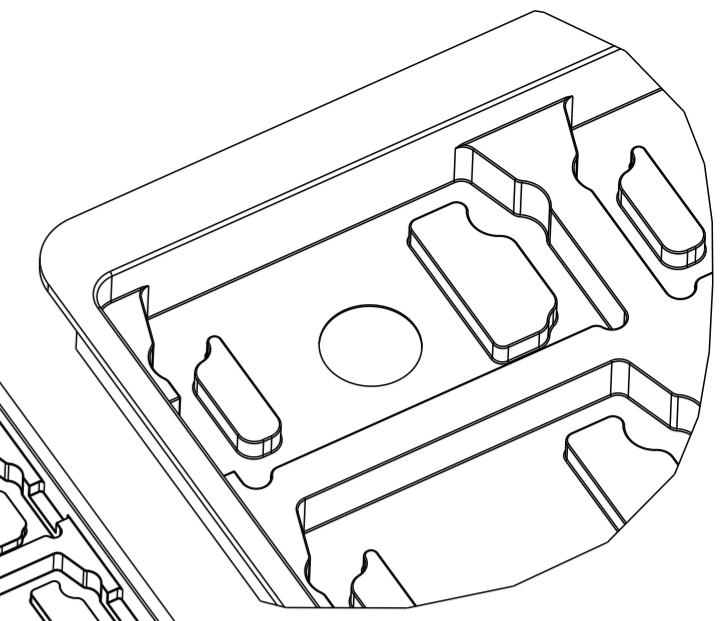
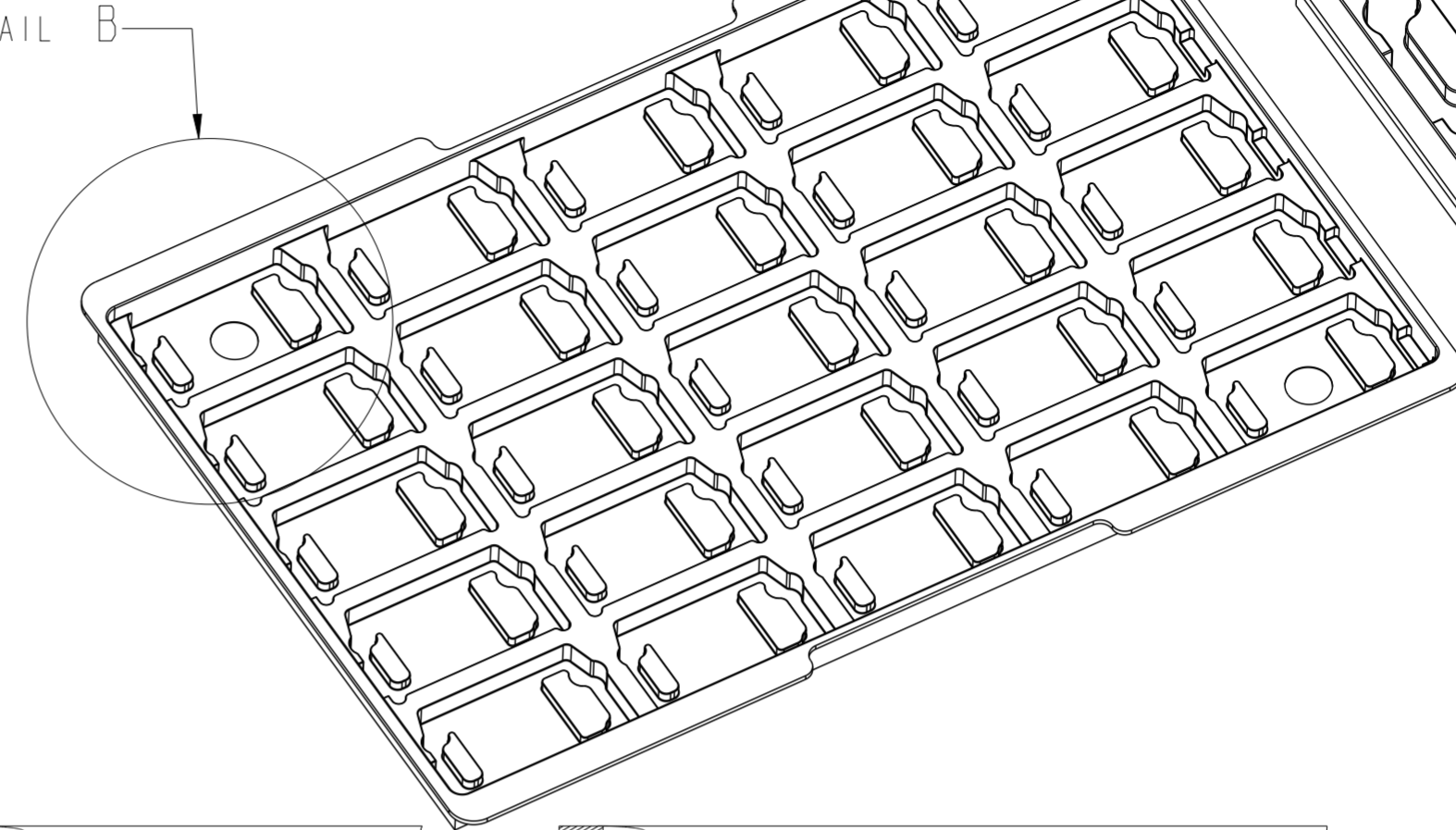

DETAIL B
SCALE 1:1

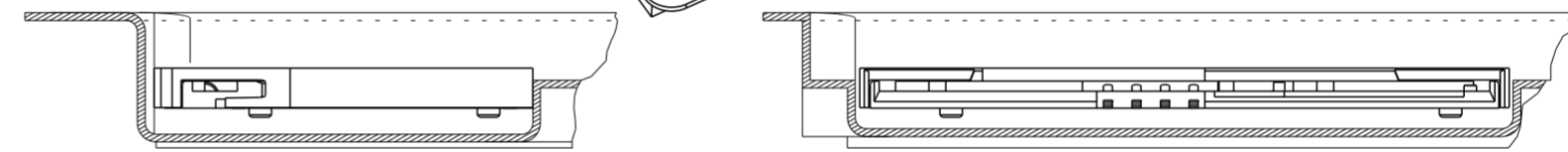

HORIZONTAL PLACEMENT

7312P0225A13LF

STANDARD VERSION

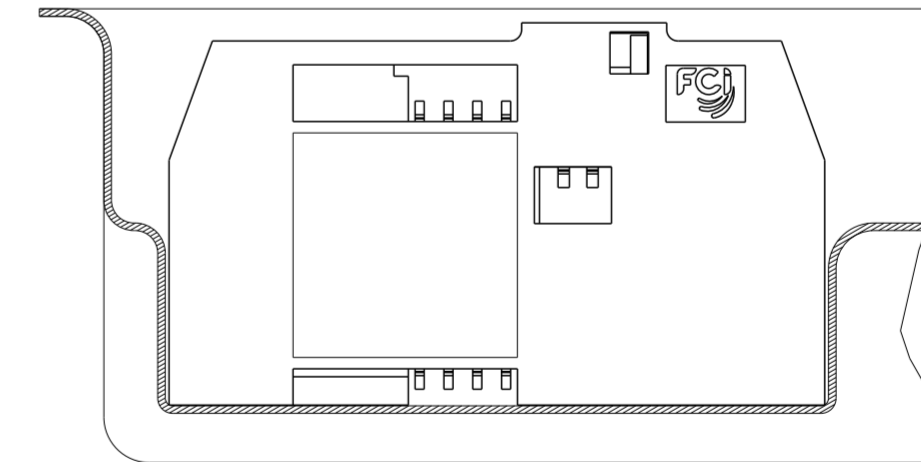
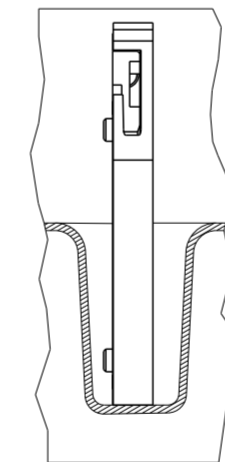

VERTICAL PLACEMENT

PACKAGING

P / N	Quantity by Tray	Trays Material Detail
7712P0225A25LF	25 Horizontal Placement	Antistatic
7312P0225A13LF	100 Vertical Placement	No Antistatic

spec ref	SEE NOTES	dr	P-Mathew Nebu	2014/09/27	projection	mm	size	A2	scale	3:2							
tolerance std	TOLERANCES UNLESS OTHERWISE SPECIFIED	eng	P-Mathew Nebu	2014/10/08		mm	ecn no	ELX-18989-1	rel level	Released							
ISO 406		chr	-														
ISO 1101		appr	K-Paul Biju	2014/10/08							product family	MOBILE I/O					
surface	<table border="1"> <tr> <td>linear</td> <td>0.X</td> <td>±0.3</td> </tr> <tr> <td></td> <td>0.XX</td> <td>±0.1</td> </tr> <tr> <td></td> <td>0.XXX</td> <td>±0.05</td> </tr> <tr> <td>angular</td> <td>0°</td> <td>±2°</td> </tr> </table>	linear	0.X	±0.3		0.XX	±0.1		0.XXX	±0.05	angular	0°	±2°		FCI title CHIP CARD CONNECTOR TYPE : P02 (8 cts with cover)	dwg no VJW53666	rev L
linear	0.X	±0.3															
	0.XX	±0.1															
	0.XXX	±0.05															
angular	0°	±2°															
ISO 1302		www.fci.com	cat. no.	SEE TABLE	Product - Customer Drw	sheet 3 of 3											



Copyright FCI.

Компания «Life Electronics» занимается поставками электронных компонентов импортного и отечественного производства от производителей и со складов крупных дистрибьюторов Европы, Америки и Азии.

С конца 2013 года компания активно расширяет линейку поставок компонентов по направлению коаксиальный кабель, кварцевые генераторы и конденсаторы (керамические, пленочные, электролитические), за счёт заключения дистрибьюторских договоров

Мы предлагаем:

- Конкуренспособные цены и скидки постоянным клиентам.
- Специальные условия для постоянных клиентов.
- Подбор аналогов.
- Поставку компонентов в любых объемах, удовлетворяющих вашим потребностям.
- Приемлемые сроки поставки, возможна ускоренная поставка.
- Доставку товара в любую точку России и стран СНГ.
- Комплексную поставку.
- Работу по проектам и поставку образцов.
- Формирование склада под заказчика.
- Сертификаты соответствия на поставляемую продукцию (по желанию клиента).
- Тестирование поставляемой продукции.
- Поставку компонентов, требующих военную и космическую приемку.
- Входной контроль качества.
- Наличие сертификата ISO.

В составе нашей компании организован Конструкторский отдел, призванный помогать разработчикам, и инженерам.

Конструкторский отдел помогает осуществить:

- Регистрацию проекта у производителя компонентов.
- Техническую поддержку проекта.
- Защиту от снятия компонента с производства.
- Оценку стоимости проекта по компонентам.
- Изготовление тестовой платы монтаж и пусконаладочные работы.



Тел: +7 (812) 336 43 04 (многоканальный)

Email: org@lifeelectronics.ru