



Future Technology Devices International Ltd.

Application Note AN_178

User Guide For

LibMPSSE – SPI

Document Reference No.: FT_000492

Version 1.0

Issue Date: 2011-08-01

This application note is a guide to using the LibMPSSE-SPI – a library which simplifies the design of firmware for interfacing to the FTDI MPSSE configured as an SPI interface. The library is available for Windows and for Linux.

Future Technology Devices International Ltd.

Unit 1, 2 Seaward Place, CenturionBusinessPark, Glasgow, G41 1HH, United Kingdom

Tel.: +44 (0) 141 429 2777 Fax: + 44 (0) 141 429 2758

E-Mail (Support): admin1@ftdichip.com Web: <http://ftdichip.com>

Copyright © 2011 Future Technology Devices International Ltd.

Table of Contents

1	Introduction	2
2	System Overview	4
3	Application Programming Interface (API).....	5
3.1	SPI Functions.....	5
3.1.1	SPI_GetNumChannels	5
3.1.2	SPI_GetChannelInfo.....	5
3.1.3	SPI_OpenChannel.....	6
3.1.4	SPI_InitChannel	6
3.1.5	SPI_CloseChannel.....	7
3.1.6	SPI_Read	7
3.1.7	SPI_Write	8
3.1.8	SPI_IsBusy	9
3.1.9	SPI_ChangeCS	9
3.2	GPIO functions.....	9
3.2.1	FT_WriteGPIO	10
3.2.2	FT_ReadGPIO.....	10
3.3	Library Infrastructure Functions	10
3.3.1	Init_libMPSSE	11
3.3.2	Cleanup_libMPSSE	11
3.4	Data types.....	11
3.4.1	ChannelConfig.....	11
3.4.2	Typedefs	13
4	Usage example.....	14
5	Contact Information.....	21
	Appendix A – Revision History	23

1 Introduction

The Multi Protocol Synchronous Serial Engine (MPSSE) is generic hardware found in several FTDI chips that allows these chips to communicate with a synchronous serial device such as an I2C device, an SPI device or a JTAG device. The MPSSE is currently available on the FT2232D, FT2232H, FT4232H and FT232H chips, which communicate with a PC (or an application processor) over the USB interface. Applications on a PC or on an embedded system communicate with the MPSSE in these chips using the D2XX USB drivers.

The MPSSE takes different commands to send out data from the chips in the different formats, namely I2C, SPI and JTAG. libMPSSE is a library that provides a user friendly API that enables users to write applications to communicate with the I2C/SPI/JTAG devices without needing to understand the MPSSE and its commands. However, if the user wishes then he/she may try to understand the working of the MPSSE and use it from their applications directly by calling D2XX functions.

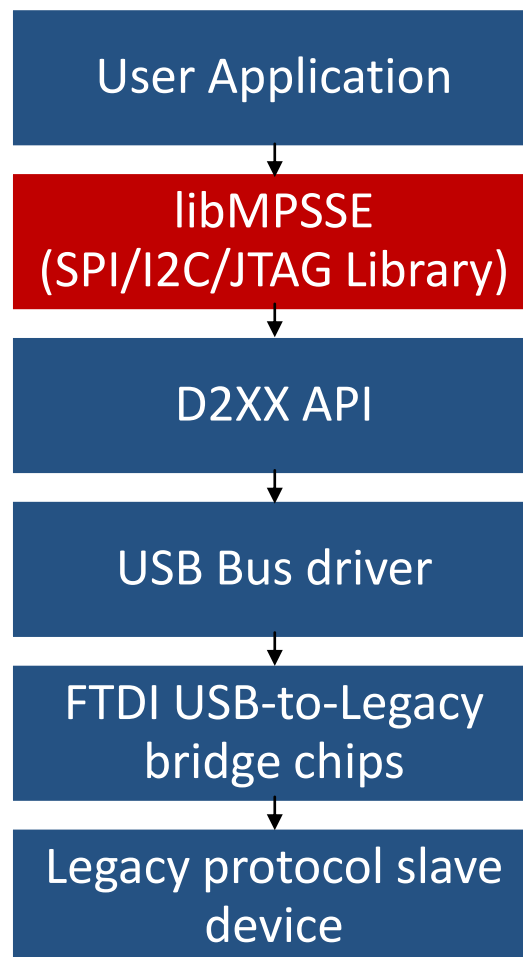

Diagram 1: The software and hardware stack through which legacy protocol data flows

As shown in the the above diagram, libMPSSE has three different APIs, one each for I2C, SPI and JTAG. This document will only describe the SPI section.

The libMPSSE.dll, (Linux or Windows versions) sample code, release notes and all necessary files can be downloaded from the FTDI website at :

http://www.ftdichip.com/Support/SoftwareExamples/MPSSE/LibMPSSE-SPI/libMPSSE-SPI_DLL_linux.zip

http://www.ftdichip.com/Support/SoftwareExamples/MPSSE/LibMPSSE-SPI/libMPSSE-SPI_DLL_Windows.zip

The sample source code contained in this application note is provided as an example and is neither guaranteed nor supported by FTDI.

2 System Overview

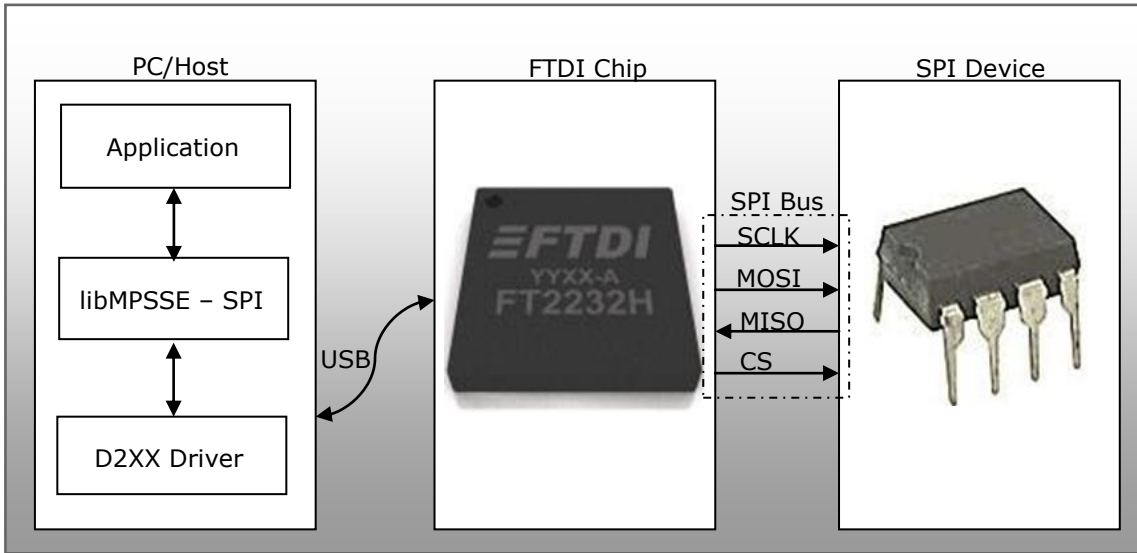

Diagram 2: System organisation

The above diagram shows how the components of the system will typically be organised. The PC/Host may be desktop/laptop machine or an embedded system. The FTDI chip and the SPI device would usually be on the same PCB. Though only one SPI device is shown in the diagram above, up to five SPI devices can actually be connected to each MPSSE.

3 Application Programming Interface (API)

The libMPSSE-SPI APIs can be divided into two broad sets. The first set consists of six control APIs and the second set consists of two data transferring APIs. All the APIs return an FT_STATUS. This is the same FT_STATUS that is defined in the [D2XX](#) driver.

3.1 SPI Functions

3.1.1 SPI_GetNumChannels

FT_STATUS **SPI_GetNumChannels** (uint32 *numChannels)

This function gets the number of SPI channels that are connected to the host system. The number of ports available in each of these chips is different.

Parameters:

out	*numChannels	The number of channels connected to the host
-----	--------------	--

Returns:

Returns status code of type FT_STATUS

Note:

FTDI's USB-to-legacy bridge chips may have multiple channels in it but not all these channels can be configured to work as SPI masters. This function returns the total number of channels connected to the host system that has a MPSSE attached to it so that it may be configured as an SPI master.

For example, if an FT2232D (1 MPSSE port), an FT232H (1 MPSSE port), an FT2232H (2 MPSSE ports) and an FT4232H (2 MPSSE ports) are connected to a PC, then a call to SPI_GetNumChannels would return 6 in numChannels.

Warning:

This function should not be called from two applications or from two threads at the same time.

3.1.2 SPI_GetChannelInfo

FT_STATUS SPI_GetChannelInfo (uint32 index, FT_DEVICE_LIST_INFO_NODE *chanInfo)

This function takes a channel index (valid values are from 0 to the value returned by SPI_GetNumChannels - 1) and provides information about the channel in the form of a populated FT_DEVICE_LIST_INFO_NODE structure.

Parameters:

in	index	Index of the channel
out	*chanInfo	Pointer to FT_DEVICE_LIST_INFO_NODE structure

Returns:

Returns status code of type FT_STATUS

Note:

This API could be called only after calling SPI_GetNumChannels.

See also:

Structure definition of FT_DEVICE_LIST_INFO_NODE is in the [D2XX Programmer's Guide](#).

Warning:

This function should not be called from two applications or from two threads at the same time.

3.1.3 SPI_OpenChannel

FT_STATUS SPI_OpenChannel (uint32 *index*, FT_HANDLE **handle*)

This function opens the indexed channel and provides a handle to it. Valid values for the index of channel can be from 0 to the value obtained using SPI_GetNumChannels - 1).

Parameters:

in	<i>index</i>	Index of the channel
out	<i>handle</i>	Pointer to the handle of type FT_HANDLE

Returns:

Returns status code of type FT_STATUS

Note:

Trying to open an already open channel will return an error code.

3.1.4 SPI_InitChannel

FT_STATUS SPI_InitChannel (FT_HANDLE *handle*, ChannelConfig **config*)

This function initializes the channel and the communication parameters associated with it.

Parameters:

in	<i>handle</i>	Handle of the channel
in	<i>config</i>	Pointer to ChannelConfig structure with the value of clock and latency timer updated
out	<i>none</i>	

Returns:

Returns status code of type FT_STATUS

See also:

Structure definition of ChannelConfig

Note:

This function internally performs what is required to get the channel operational such as resetting and enabling the MPSSE.

3.1.5 SPI_CloseChannel

FT_STATUS SPI_CloseChannel (FT_HANDLE *handle*)

Closes a channel and frees all resources that were used by it

Parameters:

in	<i>handle</i>	Handle of the channel
out	<i>none</i>	

Returns:

Returns status code of type FT_STATUS

3.1.6 SPI_Read

FT_STATUS SPI_Read(FT_HANDLE *handle*, uint8 **buffer*, uint32 *sizeToTransfer*, uint32 **sizeTransferred*, uint32 *transferOptions*)

This function reads the specified number of bits or bytes (depending on *transferOptions* parameter) from an SPI slave.

Parameters:

in	<i>handle</i>	Handle of the channel
out	<i>buffer</i>	Pointer to the buffer where data is to be read
in	<i>sizeToTransfer</i>	Number of bytes or bits to be read
out	* <i>sizeTransferred</i>	Pointer to variable containing the number of bytes or bits read
in	<i>transferOptions</i>	<p>This parameter specifies data transfer options. The bit positions defined for each of these options are:</p> <p>BIT0: if set then <i>sizeToTransfer</i> is in bits, otherwise bytes. Bit masks defined for this bit are SPI_TRANSFER_OPTIONS_SIZE_IN_BYTES and SPI_TRANSFER_OPTIONS_SIZE_IN_BITS</p> <p>BIT1: if set then the chip select line is asserted before beginning the transfer. Bit mask defined for this bit is SPI_TRANSFER_OPTIONS_CHIPSELECT_ENABLE</p> <p>BIT2: if set then the chip select line is disasserted after the transfer ends. Bit mask defined for this bit is SPI_TRANSFER_OPTIONS_CHIPSELECT_DISABLE</p>

		BIT3 – BIT31: reserved
--	--	------------------------

Returns:

Returns status code of type FT_STATUS

Warning:

This is a blocking function and will not return until either the specified amount of data are read or an error is encountered.

3.1.7 SPI_Write

FT_STATUS SPI_Write(FT_HANDLE handle, uint8 *buffer, uint32 sizeToTransfer, uint32 *sizeTransferred, uint32 transferOptions)

This function writes the specified number of bits or bytes (depending on *transferOptions* parameter) to a SPI slave.

Parameters:

in	<i>handle</i>	Handle of the channel
out	<i>buffer</i>	Pointer to the buffer from where data is to be written
in	<i>sizeToTransfer</i>	Number of bytes or bits to write
out	<i>*sizeTransferred</i>	Pointer to variable containing the number of bytes or bits written
in	<i>transferOptions</i>	<p>This parameter specifies data transfer options. The bit positions defined for each of these options are:</p> <p>BIT0: if set then <i>sizeToTransfer</i> is in bits, otherwise bytes. Bit masks defined for this bit are SPI_TRANSFER_OPTIONS_SIZE_IN_BYTES and SPI_TRANSFER_OPTIONS_SIZE_IN_BITS</p> <p>BIT1: if set then the chip select line is asserted before beginning the transfer. Bit mask defined for this bit is SPI_TRANSFER_OPTIONS_CHIPSELECT_ENABLE</p> <p>BIT2: if set then the chip select line is disasserted after the transfer ends. Bit mask defined for this bit is SPI_TRANSFER_OPTIONS_CHIPSELECT_DISABLE</p> <p>BIT3 – BIT31: reserved</p>

Returns:

Returns status code of type FT_STATUS

Warning:

This is a blocking function and will not return until either the specified amount of data is read or an error is encountered.

Returns:

Returns status code of type FT_STATUS

Warning:

This is a blocking function and will not return until either the specified amount of data is read or an error is encountered.

3.1.8 SPI_IsBusy

FT_STATUS SPI_IsBusy(FT_HANDLE *handle*, bool **state*)

This function reads the state of the MISO line without clocking the SPI bus.

Some applications need the SPI master to poll the MISO line without clocking the bus to check if the SPI slave has completed previous operation and is ready for the next operation. This function is useful for such applications.

Parameters:

in	<i>handle</i>	Handle of the channel
out	* <i>state</i>	Pointer to a variable to which the state of the MISO line will be read

Returns:

Returns status code of type FT_STATUS

3.1.9 SPI_ChangeCS

SPI_ChangeCS(FT_HANDLE *handle*, uint32 *configOptions*)

This function changes the chip select line that is to be used to communicate to the SPI slave.

Parameters:

in	<i>handle</i>	Handle of the channel
in	<i>configOptions</i>	This parameter provides a way to select the chip select line and the slave's SPI mode. It is the same parameter as <i>ConfigChannel.configOptions</i> that is passed to function SPI_InitChannel and it is explained in section 3.4.1

Returns:

Returns status code of type FT_STATUS

3.2 GPIO functions

Each MPSSE channel in the FTDI chips are provided with a general purpose I/O port having 8 lines in addition to the port that is used for synchronous serial communication. For example, the FT223H has only one MPSSE channel with two 8-bit busses, ADBUS and ACBUS. Out of these, ADBUS is used for synchronous serial communications (I2C/SPI/JTAG) and ACBUS is free to be used as GPIO. The two functions described below have been provided to access these GPIO lines(also called the higher byte lines of MPSSE) that are available in various FTDI chips with MPSSEs.

3.2.1 FT_WriteGPIO

FT_STATUS FT_WriteGPIO(FT_HANDLE handle, uint8 dir, uint8 value)

This function writes to the 8 GPIO lines associated with the high byte of the MPSSE channel

Parameters:

in	<i>handle</i>	Handle of the channel
in	<i>dir</i>	Each bit of this byte represents the direction of the 8 respective GPIO lines. 0 for in and 1 for out
in	<i>value</i>	If the direction of a GPIO line is set to output, then each bit of this byte represent the output logic state of the 8 respective GPIO lines. 0 for logic low and 1 for logic high

Returns:

Returns status code of type FT_STATUS

3.2.2 FT_ReadGPIO

FT_STATUS FT_ReadGPIO(FT_HANDLE handle, uint8 *value)

This function reads from the 8 GPIO lines associated with the high byte of the MPSSE channel

Parameters:

in	<i>handle</i>	Handle of the channel
out	<i>*value</i>	If the direction of a GPIO line is set to input, then each bit of this byte represent the input logic state of the 8 respective GPIO lines. 0 for logic low and 1 for logic high

Returns:

Returns status code of type FT_STATUS

Note:

The direction of the GPIO line must first be set using FT_WriteGPIO function before this function is used.

3.3 Library Infrastructure Functions

The two functions described in this section typically do not need to be called from the user applications as they are automatically called during entry/exit time. However, these functions are not called automatically when linking the library statically using Microsoft Visual C++. It is then that they need to be called explicitly from the user applications. The static linking sample provided with this manual uses a macro which checks if the code is compiled using Microsoft toolchain, if so then it automatically calls these functions.

3.3.1 Init_libMPSSE

void Init_libMPSSE(void)

Initializes the library

Parameters:

in	none	
out	none	

Returns:

void

3.3.2 Cleanup_libMPSSE

void Cleanup_libMPSSE(void)

Cleans up resources used by the library

Parameters:

in	none	
out	none	

Returns:

void

3.4 Data types

3.4.1 ChannelConfig

ChannelConfig is a structure that holds the parameters used for initializing a channel. The following are members of the structure:

uint32 ClockRate

This parameter takes the value of the clock rate of the SPI bus in hertz. Valid range for ClockRate is 0 to 30MHz.

uint8 LatencyTimer

Required value, in milliseconds, of latency timer. Valid range is 0 – 255. However, FTDI recommend the following ranges of values for the latency timer:

Range for full speed devices (FT2232D): Range 2 – 255

Range for Hi-speed devices (FT232H, FT2232H, FT4232H): Range 1 - 255

uint32 configOptions

Bits of this member are used in the way described below:

Bit number	Description	Value	Meaning of value	Defined macro(if any)
BIT1-	These bits	00	SPI MODE0	SPI_CONFIG_OPTION_MODE0

BIT0	specify to which of the standard SPI modes should the SPI master be configured to	01	SPI MODE1	SPI_CONFIG_OPTION_MODE1 (Please refer to the release notes within the release package zip file for revision history and known limitations of this version)
		10	SPI MODE2	SPI_CONFIG_OPTION_MODE2
		11	SPI MODE3	SPI_CONFIG_OPTION_MODE3 (Please refer to the release notes within the release package zip file for revision history and known limitations of this version)
BIT4-BIT2	These bits specify which of the available lines should be used as chip select	000	xDBUS3 of MPSSE is chip select	SPI_CONFIG_OPTION_CS_DBUS3
		001	xDBUS4 of MPSSE is chip select	SPI_CONFIG_OPTION_CS_DBUS4
		010	xDBUS5 of MPSSE is chip select	SPI_CONFIG_OPTION_CS_DBUS5
		011	xDBUS6 of MPSSE is chip select	SPI_CONFIG_OPTION_CS_DBUS6
		100	xDBUS7 of MPSSE is chip select	SPI_CONFIG_OPTION_CS_DBUS7
BIT5	This bit specifies if the chip select line should be active low	0	Chip select is active high	
		1	Chip select is active low	SPI_CONFIG_OPTION_CS_ACTIVELOW
BIT6-BIT31	Reserved			

Note: The terms xDBUS0 – xDBUS7 corresponds to lines ADBUS0 – ADBUS7 if the first MPSSE channel is used, otherwise it corresponds to lines BDBUS0 – BDBUS7 if the second MPSSE channel(i.e. if available in the chip) is used.

The SPI modes are:

- SPI MODE0 - data are captured on rising edge and propagated on falling edge
- SPI MODE1 - data are captured on falling edge and propagated on rising edge
- SPI MODE2 - data are captured on falling edge and propagated on rising edge
- SPI MODE3 - data are captured on rising edge and propagated on falling edge

uint32 Pins

This member specifies the directions and values of the lines associated with the lower byte of the MPSSE channel after SPI_InitChannel and SPI_CloseChannel functions are called.

Bit number	Description	Comment
BIT7-BIT0	Direction of the lines after SPI_InitChannel is called	A 1 corresponds to output and a 0 corresponds to input

BIT15-BIT8	Value of the lines after SPI_InitChannel is called	A 1 corresponds to logic high and a 0 corresponds to logic low
BIT23-BIT16	Direction of the lines after SPI_CloseChannel is called	A 1 corresponds to output and a 0 corresponds to input
BIT31-BIT24	Value of the lines after SPI_CloseChannel is called	A 1 corresponds to logic high and a 0 corresponds to logic low

Note that the directions of the SCLK, MOSI and the specified chip select line will be overwritten to 1 and the direction of the MISO like will be overwritten to 0 irrespective of the values passed by the user application.

uint16 reserved

This parameter is reserved and should not be used.

3.4.2 Typedefs

Following are the typedefs that have been defined keeping cross platform portability in view:

- typedef unsigned char **uint8**
- typedef unsigned short **uint16**
- typedef unsigned long **uint32**
- typedef signed char **int8**
- typedef signed short **int16**
- typedef signed long **int32**
- typedef unsigned char **bool**

```

/*!
 * \file sample-static.c
 *
 * \author FTDI
 * \date 20110512
 *
 * Copyright © 2011 Future Technology Devices International Limited
 * Company Confidential
 *
 * Project: libMPSSE
 * Module: SPI Sample Application - Interfacing 94LC56B SPI EEPROM
 *
 * Revision History:
 * 0.1 - 20110512 - Initial version
 * 0.2 - 20110801 - Changed LatencyTimer to 255
 *
 *                               Attempt to open channel only if available
 *                               Added & modified macros
 *                               Included stdlib.h
 */

#include<stdio.h>
#include<stdlib.h>
#ifdef _WIN32
#include<windows.h>
#endif
#include "libMPSSE_spi.h"
#include "ftd2xx.h"

#define APP_CHECK_STATUS(exp) {if(exp!=FT_OK){printf("%s:%d:%s(): status(0x%x) != FT_OK\n",__FILE__, __LINE__,
__FUNCTION__,exp);exit(1);}else{}};
#define CHECK_NULL(exp){if(exp==NULL){printf("%s:%d:%s(): NULL expression encountered \n",__FILE__, __LINE__,
__FUNCTION__);exit(1);}else{}};

#define SPI_DEVICE_BUFFER_SIZE          256
#define SPI_WRITE_COMPLETION_RETRY      10
#define START_ADDRESS_EEPROM           0x00
#define END_ADDRESS_EEPROM              0x10
#define RETRY_COUNT_EEPROM              10
#define CHANNEL_TO_OPEN                  0 /*0 for first available channel, 1 for next... */
#define SPI_SLAVE_0                      0
#define SPI_SLAVE_1                      1
#define SPI_SLAVE_2                      2

/* Options-Bit0: If this bit is 0 then it means that the transfer size provided is in bytes */
#define SPI_TRANSFER_OPTIONS_SIZE_IN_BYTES 0x00000000
/* Options-Bit0: If this bit is 1 then it means that the transfer size provided is in bytes */
#define SPI_TRANSFER_OPTIONS_SIZE_IN_BITS 0x00000001
/* Options-Bit1: if BIT1 is 1 then CHIP_SELECT line will be enables at start of transfer */
#define SPI_TRANSFER_OPTIONS_CHIPSELECT_ENABLE 0x00000002
/* Options-Bit2: if BIT2 is 1 then CHIP_SELECT line will be disabled at end of transfer */
#define SPI_TRANSFER_OPTIONS_CHIPSELECT_DISABLE 0x00000004

uint32 channels;
FT_HANDLE ftHandle;
ChannelConfig channelConf;
uint8 buffer[SPI_DEVICE_BUFFER_SIZE];

FT_STATUS read_byte(uint8 slaveAddress, uint8 address, uint16 *data)
{
    uint32 sizeToTransfer = 0;
    uint32 sizeTransferred;
    bool writeComplete=0;
    uint32 retry=0;
    bool state;
    FT_STATUS status;

    /* CS_High + Write command + Address */
    sizeToTransfer=1;
    sizeTransferred=0;
    buffer[0] = 0xC0;/* Write command (3bits)*/

```



```

buffer[0] = buffer[0] | ( ( address >> 3) & 0x0F );/* plus 5 most significant address bits */
status = SPI_Write(ftHandle, buffer, sizeToTransfer, &sizeTransferred,
    SPI_TRANSFER_OPTIONS_SIZE_IN_BYTES|
    SPI_TRANSFER_OPTIONS_CHIPSELECT_ENABLE);
APP_CHECK_STATUS(status);

/*Write partial address bits */
sizeToTransfer=4;
sizeTransferred=0;
buffer[0] = ( address & 0x07 ) << 5; /* least significant 3 address bits */
status = SPI_Write(ftHandle, buffer, sizeToTransfer, &sizeTransferred,
    SPI_TRANSFER_OPTIONS_SIZE_IN_BITS);
APP_CHECK_STATUS(status);

/*Read 2 bytes*/
sizeToTransfer=2;
sizeTransferred=0;
status = SPI_Read(ftHandle, buffer, sizeToTransfer, &sizeTransferred,
    SPI_TRANSFER_OPTIONS_SIZE_IN_BYTES|
    SPI_TRANSFER_OPTIONS_CHIPSELECT_DISABLE);
APP_CHECK_STATUS(status);

*data = (uint16)(buffer[1]<<8);
*data = (*data & 0xFF00) | (0x00FF & (uint16)buffer[0]);

return status;
}

```

FT_STATUS write_byte(uint8 slaveAddress, uint8 address, uint16 data)

```

{
    uint32 sizeToTransfer = 0;
    uint32 sizeTransferred=0;
    bool writeComplete=0;
    uint32 retry=0;
    bool state;
    FT_STATUS status;

    /* Write command EWEN(with CS_High -> CS_Low) */
    sizeToTransfer=11;
    sizeTransferred=0;
    buffer[0]=0x9F;/* SPI_EWEN -> binary 10011xxxxxx (11bits) */
    buffer[1]=0xFF;
    status = SPI_Write(ftHandle, buffer, sizeToTransfer, &sizeTransferred,
        SPI_TRANSFER_OPTIONS_SIZE_IN_BITS|
        SPI_TRANSFER_OPTIONS_CHIPSELECT_ENABLE|
        SPI_TRANSFER_OPTIONS_CHIPSELECT_DISABLE);
    APP_CHECK_STATUS(status);

    /* CS_High + Write command + Address */
    sizeToTransfer=1;
    sizeTransferred=0;
    buffer[0] = 0xA0;/* Write command (3bits) */
    buffer[0] = buffer[0] | ( ( address >> 3) & 0x0F );/* plus 5 most significant address bits */
    status = SPI_Write(ftHandle, buffer, sizeToTransfer, &sizeTransferred,
        SPI_TRANSFER_OPTIONS_SIZE_IN_BYTES|
        SPI_TRANSFER_OPTIONS_CHIPSELECT_ENABLE);
    APP_CHECK_STATUS(status);

    /*Write 3 least sig address bits */
    sizeToTransfer=3;
    sizeTransferred=0;
    buffer[0] = ( address & 0x07 ) << 5; /* least significant 3 address bits */
    status = SPI_Write(ftHandle, buffer, sizeToTransfer, &sizeTransferred,
        SPI_TRANSFER_OPTIONS_SIZE_IN_BITS);
    APP_CHECK_STATUS(status);

    /* Write 2 byte data + CS_Low */
    sizeToTransfer=2;
    sizeTransferred=0;
    buffer[0] = (uint8)(data & 0xFF);
    buffer[1] = (uint8)((data & 0xFF00)>>8);
}

```

```

status = SPI_Write(ftHandle, buffer, sizeToTransfer, &sizeTransferred,
    SPI_TRANSFER_OPTIONS_SIZE_IN_BYTES|
    SPI_TRANSFER_OPTIONS_CHIPSELECT_DISABLE);
APP_CHECK_STATUS(status);

/* Wait until D0 is high */
#if 1
/* Strobe Chip Select */
sizeToTransfer=0;
sizeTransferred=0;
status = SPI_Write(ftHandle, buffer, sizeToTransfer, &sizeTransferred,
    SPI_TRANSFER_OPTIONS_SIZE_IN_BITS|
    SPI_TRANSFER_OPTIONS_CHIPSELECT_ENABLE);
APP_CHECK_STATUS(status);
#else
#ifdef __linux__
Sleep(10);
#endif
sizeToTransfer=0;
sizeTransferred=0;
status = SPI_Write(ftHandle, buffer, sizeToTransfer, &sizeTransferred,
    SPI_TRANSFER_OPTIONS_SIZE_IN_BITS|
    SPI_TRANSFER_OPTIONS_CHIPSELECT_DISABLE);
APP_CHECK_STATUS(status);
#endif
retry=0;
state=FALSE;
SPI_IsBusy(ftHandle,&state);
while((FALSE==state) && (retry<SPI_WRITE_COMPLETION_RETRY))
{
    printf("SPI device is busy(%u)\n", (unsigned)retry);
    SPI_IsBusy(ftHandle,&state);
    retry++;
}
#endif
/* Write command EWEN(with CS_High -> CS_Low) */
sizeToTransfer=11;
sizeTransferred=0;
buffer[0]=0x8F; /* SPI_EWEN -> binary 10011xxxxxx (11bits) */
buffer[1]=0xFF;
status = SPI_Write(ftHandle, buffer, sizeToTransfer, &sizeTransferred,
    SPI_TRANSFER_OPTIONS_SIZE_IN_BITS|
    SPI_TRANSFER_OPTIONS_CHIPSELECT_ENABLE|
    SPI_TRANSFER_OPTIONS_CHIPSELECT_DISABLE);
APP_CHECK_STATUS(status);
return status;
}

int main()
{
    FT_STATUS status;
    FT_DEVICE_LIST_INFO_NODE devList;
    uint8 address=0;
    uint16 data;
    int i,j;
    uint32 sizeToTransfer, sizeTransferred;
#ifdef _MSC_VER
    Init_libMPSSE();
#endif
channelConf.ClockRate = 5000;
channelConf.LatencyTimer= 255;
channelConf.configOptions = SPI_CONFIG_OPTION_MODE0| SPI_CONFIG_OPTION_CS_DBUS3;
channelConf.Pin = 0x00000000; /* FinalVal-FinalDir-InitVal-InitDir (for dir: 0=in, 1=out) */

status = SPI_GetNumChannels(&channels);
APP_CHECK_STATUS(status);
printf("Number of available SPI channels = %d\n", channels);

if(channels>0)
{
    for(i=0;i<channels;i++)
    {
        status = SPI_GetChannelInfo(i,&devList);
    }
}

```

```
APP_CHECK_STATUS(status);
printf("Information on channel number %d:\n",i);
/* print the dev info */
printf("      Flags=0x%x\n",devList.Flags);
printf("      Type=0x%x\n",devList.Type);
printf("      ID=0x%x\n",devList.ID);
printf("      LocId=0x%x\n",devList.LocId);
printf("      SerialNumber=%s\n",devList.SerialNumber);
printf("      Description=%s\n",devList.Description);
printf("      ftHandle=0x%x\n",devList.ftHandle);/* always 0 unless open */
}

status = SPI_OpenChannel(CHANNEL_TO_OPEN,&ftHandle);/* Open the first available channel */
APP_CHECK_STATUS(status);
printf("\nhandle=0x%x status=0x%x\n",ftHandle,status);
status = SPI_InitChannel(ftHandle,&channelConf);

for(address=START_ADDRESS_EEPROM;address<END_ADDRESS_EEPROM;address++)
{
    printf("writing byte at address = %d \n",address);
    write_byte(SPI_SLAVE_0, address,(uint16)address+1);
}

for(address=START_ADDRESS_EEPROM;address<END_ADDRESS_EEPROM;address++)
{
    read_byte(SPI_SLAVE_0, address,&data);
    printf("read address=0x%x data=0x%x\n",address,data);
}

status = SPI_CloseChannel(ftHandle);
}

#ifdef _MSC_VER
    Cleanup_libMPSSE();
#endif

return 0;
}
```

The sample program shown above writes to address 0 through 15 in the EEPROM chip. The value that is written is *address+1*, i.e. if the address is 5 then a value 6 is written to that address. When this sample program is compiled and run, we should see an output like the one shown below:

```

C:\Windows\system32\cmd.exe
Number of available SPI channels = 2
Information on channel number 0:
    Flags=0x2
    Type=0x6
    ID=0x4036010
    LocId=0x831
    SerialNumber=FTTPA0K3A
    Description=FT2232H MiniModule A
    ftHandle=0x0
Information on channel number 1:
    Flags=0x2
    Type=0x6
    ID=0x4036010
    LocId=0x832
    SerialNumber=FTTPA0K3B
    Description=FT2232H MiniModule B
    ftHandle=0x0

handle=0x390ab8 status=0x0
writing byte at address = 0
writing byte at address = 1
writing byte at address = 2
writing byte at address = 3
writing byte at address = 4
writing byte at address = 5
writing byte at address = 6
writing byte at address = 7
writing byte at address = 8
writing byte at address = 9
writing byte at address = 10
writing byte at address = 11
writing byte at address = 12
writing byte at address = 13
writing byte at address = 14
writing byte at address = 15
read address=0x0 data=0x1
read address=0x1 data=0x2
read address=0x2 data=0x3
read address=0x3 data=0x4
read address=0x4 data=0x5
read address=0x5 data=0x6
read address=0x6 data=0x7
read address=0x7 data=0x8
read address=0x8 data=0x9
read address=0x9 data=0xa
read address=0xa data=0xb
read address=0xb data=0xc
read address=0xc data=0xd
read address=0xd data=0xe
read address=0xe data=0xf
read address=0xf data=0x10
  
```

Diagram 4: Sample output on windows

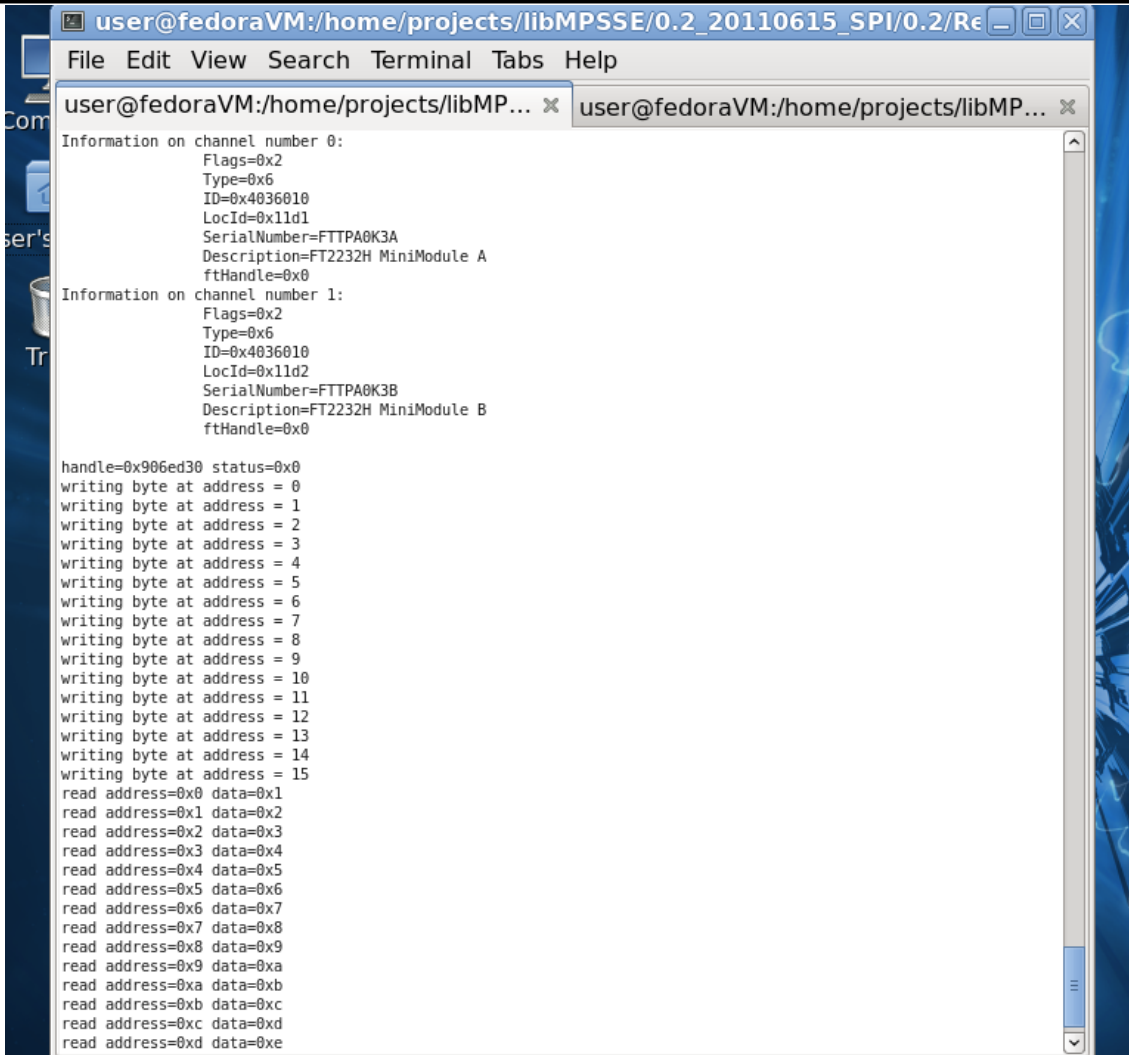

```
user@fedoraVM:/home/projects/libMPSSE/0.2_20110615_SPI/0.2/Re...
File Edit View Search Terminal Tabs Help
user@fedoraVM:/home/projects/libMPSSE/0.2_20110615_SPI/0.2/Re...
Information on channel number 0:
    Flags=0x2
    Type=0x6
    ID=0x4036010
    LocId=0x11d1
    SerialNumber=FTTPA0K3A
    Description=FT2232H MiniModule A
    ftHandle=0x0
Information on channel number 1:
    Flags=0x2
    Type=0x6
    ID=0x4036010
    LocId=0x11d2
    SerialNumber=FTTPA0K3B
    Description=FT2232H MiniModule B
    ftHandle=0x0

handle=0x906ed30 status=0x0
writing byte at address = 0
writing byte at address = 1
writing byte at address = 2
writing byte at address = 3
writing byte at address = 4
writing byte at address = 5
writing byte at address = 6
writing byte at address = 7
writing byte at address = 8
writing byte at address = 9
writing byte at address = 10
writing byte at address = 11
writing byte at address = 12
writing byte at address = 13
writing byte at address = 14
writing byte at address = 15
read address=0x0 data=0x1
read address=0x1 data=0x2
read address=0x2 data=0x3
read address=0x3 data=0x4
read address=0x4 data=0x5
read address=0x5 data=0x6
read address=0x6 data=0x7
read address=0x7 data=0x8
read address=0x8 data=0x9
read address=0x9 data=0xa
read address=0xa data=0xb
read address=0xb data=0xc
read address=0xc data=0xd
read address=0xd data=0xe
```

Diagram 5: Sample output on linux

5 Contact Information

Head Office – Glasgow, UK

Future Technology Devices International Limited
Unit 1,2 Seaward Place, Centurion Business Park
Glasgow G41 1HH
United Kingdom
Tel: +44 (0) 141 429 2777
Fax: +44 (0) 141 429 2758

E-mail (Sales) sales1@ftdichip.com
E-mail (Support) support1@ftdichip.com
E-mail (General Enquiries) admin1@ftdichip.com
Web Site URL <http://www.ftdichip.com>
Web Shop URL <http://www.ftdichip.com>

Branch Office – Taipei, Taiwan

Future Technology Devices International Limited (Taiwan)
2F, No. 516, Sec. 1, NeiHu Road
Taipei 114
Taiwan, R.O.C.
Tel: +886 (0) 2 8791 3570
Fax: +886 (0) 2 8791 3576

E-mail (Sales) tw.sales1@ftdichip.com
E-mail (Support) tw.support1@ftdichip.com
E-mail (General Enquiries) tw.admin1@ftdichip.com
Web Site URL <http://www.ftdichip.com>

Branch Office – Hillsboro, Oregon, USA

Future Technology Devices International Limited (USA)
7235 NW Evergreen Parkway, Suite 600
Hillsboro, OR 97123-5803
USA
Tel: +1 (503) 547 0988
Fax: +1 (503) 547 0987

E-Mail (Sales) us.sales@ftdichip.com
E-Mail (Support) us.support@ftdichip.com
E-Mail (General Enquiries) us.admin@ftdichip.com
Web Site URL <http://www.ftdichip.com>

Branch Office – Shanghai, China

Future Technology Devices International Limited (China)
Room 408, 317 Xianxia Road,
Shanghai, 200051
China
Tel: +86 21 62351596
Fax: +86 21 62351595

E-mail (Sales) cn.sales@ftdichip.com
E-mail (Support) cn.support@ftdichip.com
E-mail (General Enquiries) cn.admin@ftdichip.com
Web Site URL <http://www.ftdichip.com>

Neither the whole nor any part of the information contained in, or the product described in this manual, may be adapted or reproduced in any material or electronic form without the prior written consent of the copyright holder. This product and its documentation are supplied on an as-is basis and no warranty as to their suitability for any particular purpose is either made or implied. Future Technology Devices International Ltd. will not accept any claim for damages howsoever arising as a result of use or failure of this product. Your statutory rights are not affected. This product or any variant of it is not intended for use in any medical appliance, device or system in which the failure of the product might reasonably be expected to result in personal injury. This document provides preliminary information that may be subject to change without notice. No freedom to use patents or other intellectual property rights is implied by the publication of this document. Future Technology Devices International Ltd., Unit 1, 2 Seaward Place, Centurion Business Park, Glasgow, G41 1HH United Kingdom. Scotland Registered Number:

Appendix A – Revision History

Revision	Date	Details
1.0	2011-08-01	First release

Компания «Life Electronics» занимается поставками электронных компонентов импортного и отечественного производства от производителей и со складов крупных дистрибьюторов Европы, Америки и Азии.

С конца 2013 года компания активно расширяет линейку поставок компонентов по направлению коаксиальный кабель, кварцевые генераторы и конденсаторы (керамические, пленочные, электролитические), за счёт заключения дистрибьюторских договоров

Мы предлагаем:

- Конкурентоспособные цены и скидки постоянным клиентам.
- Специальные условия для постоянных клиентов.
- Подбор аналогов.
- Поставку компонентов в любых объемах, удовлетворяющих вашим потребностям.
- Приемлемые сроки поставки, возможна ускоренная поставка.
- Доставку товара в любую точку России и стран СНГ.
- Комплексную поставку.
- Работу по проектам и поставку образцов.
- Формирование склада под заказчика.
- Сертификаты соответствия на поставляемую продукцию (по желанию клиента).
- Тестирование поставляемой продукции.
- Поставку компонентов, требующих военную и космическую приемку.
- Входной контроль качества.
- Наличие сертификата ISO.

В составе нашей компании организован Конструкторский отдел, призванный помогать разработчикам, и инженерам.

Конструкторский отдел помогает осуществить:

- Регистрацию проекта у производителя компонентов.
- Техническую поддержку проекта.
- Защиту от снятия компонента с производства.
- Оценку стоимости проекта по компонентам.
- Изготовление тестовой платы монтаж и пусконаладочные работы.



Тел: +7 (812) 336 43 04 (многоканальный)

Email: org@lifeelectronics.ru