

General Specifications

Electrical Capacity (Resistive Load)

Low/Logic Level: 50mA @ 24V DC maximum

Other Ratings

Contact Resistance: 100 milliohms maximum

Insulation Resistance: 100 megohms minimum @ 250V DC

Dielectric Strength: 250V AC minimum between contacts & between contacts & case for 1 minute minimum

Mechanical Life: 100,000 operations minimum

Electrical Life: 100,000 operations minimum

Nominal Operating Force: 1.57N

Total Travel: .010" (.250mm)

Materials & Finishes

Actuator: Glass fiber reinforced polyamide (UL94V-0)

Case: Stainless steel

Seal: Polytetrafluoroethylene

Base: Polyphthalamide (UL94V-0)

Movable Contacts: Beryllium copper with silver plating

Stationary Contacts: Brass with silver plating

Terminals: Brass with silver plating

Environmental Data

Operating Temperature Range: -25°C through +70°C (-13°F through +158°F)

Humidity: 90 ~ 95% humidity for 96 hours @ 40°C (104°F)

Vibration: 10 ~ 55Hz with peak-to-peak amplitude of 1.5mm traversing the frequency range & returning in 1 minute; 3 right angled directions for 2 hours

Shock: 50G (490m/s²) acceleration (tested in 6 right angled directions, with 5 shocks in each direction)

Processing

Soldering: Reflow Soldering Recommended. See Profile A in Supplement section.

Manual Soldering: See Profile A in Supplement section.

Cleaning: Automated cleaning. See Cleaning Specifications in Supplement section.

Standards & Certifications

Flammability Standards: UL94V-0 actuator & base

The CB3 Series tactiles have not been tested for UL recognition or CSA certification.

These switches are designed for use in a low-voltage, low-current, logic-level circuit.

When used as intended in a logic-level circuit, the results do not produce hazardous energy.

Distinctive Characteristics

Sealed construction prevents contact contamination and allows automated soldering and cleaning.

.244" (6.2mm) square body allows compact mounting.

Heat tolerant resin used for actuator and base meets UL flammability rating of 94V-0 and maintains switch reliability through vapor phase and infrared convection reflow soldering.

Dome contact gives crisp tactile feedback to positively indicate circuit transfer and assures high reliability and long life – more than 100,000 operations.

Gull-winged terminals ensure mechanical stability during soldering and simplify solder joint inspection.

Insert molded terminals lock out flux, solvents, and other contaminants.

Packaged in tape-reel or partitioned tray. Tape-reel packaging meets EIA-481-D Standard.

Coplanarity: all considered surfaces must lie between two parallel planes that are a maximum distance apart of .0059" (0.15mm). (Additional coplanarity details in Terms and Acronyms in the Supplement section.)

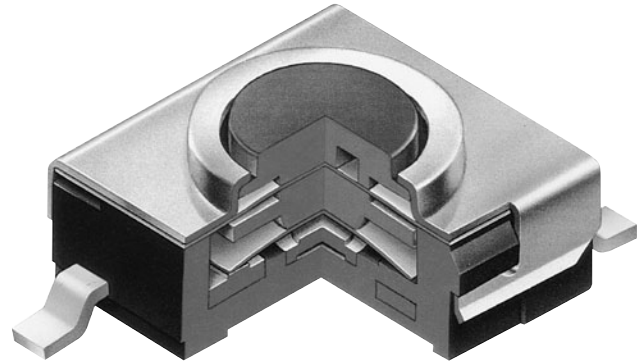

Actual Size

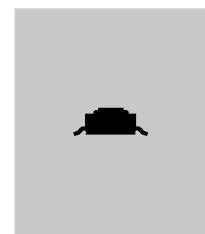

TYPICAL SWITCH ORDERING EXAMPLE

Ordering Example: **CB3** - **15** - **F** - **P** - []

Pole & Circuit			
15	SPST	OFF	(ON)
() = Momentary			

Actuator	
F	Flat Button

Terminals	
P	Gull Wing for Upright Mount

Packaging	
R	Tape-Reel 1,000 Pieces/Reel
No Code	Partitioned Tray

DESCRIPTION FOR TYPICAL ORDERING EXAMPLE

CB315FP

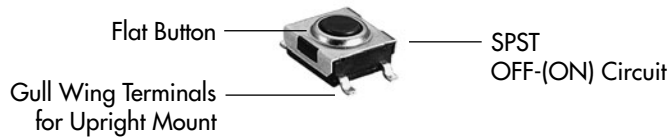

POLE & CIRCUIT

Pole	Model	Actuator Position () = Momentary		Switch Throw & Schematic	Note: Terminal numbers are not actually on switch.
		Normal	Down		
SP	CB315	OFF	(ON)	SPST 	

TYPICAL SWITCH DIMENSIONS

Single Pole • Single Throw

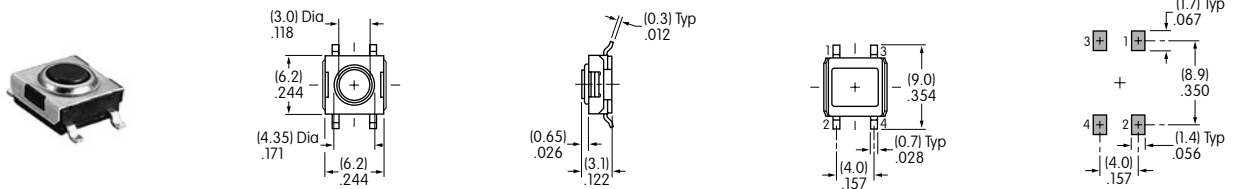

CB315FP

Toggles
Rockers
Pushbuttons
Illuminated PB
Programmable
Keylocks
Rotaries
Slides
Tactiles
Tilt
Touch
Indicators
Accessories
Supplement

PACKAGING

R

Tape-Reel (packaged to EIA-481-D standard)

Switches must be ordered in 1,000-piece increments when tape-reel packaging is selected.

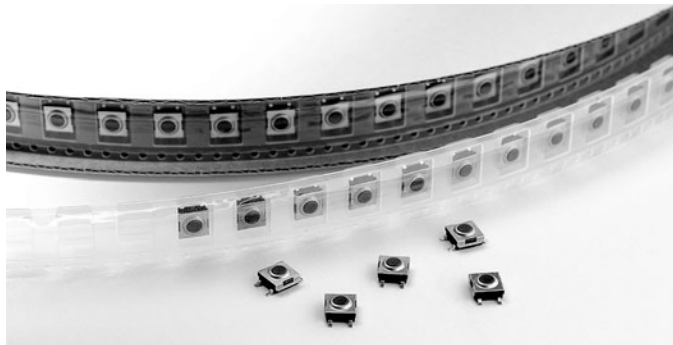

No Code

Partitioned Tray

If less than 1,000 pieces are ordered, the switches are packaged in a partitioned tray. No code is required.

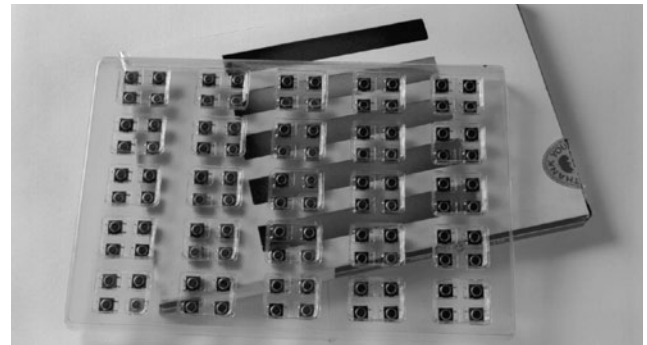

Tape-Reel Dimensions & Specifications

Each tape-reel of 1,050 pockets contains 1,000 switches

Minimum Leader Length: 16.54" (420mm) Minimum Trailer Length: 7.09" (180mm)

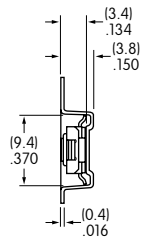
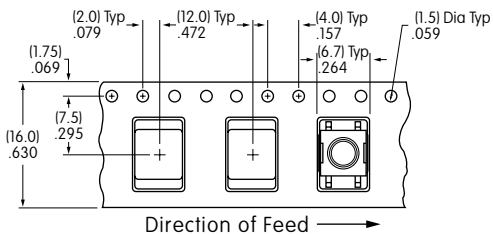
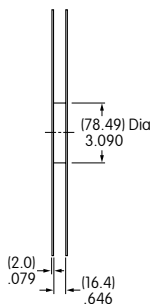
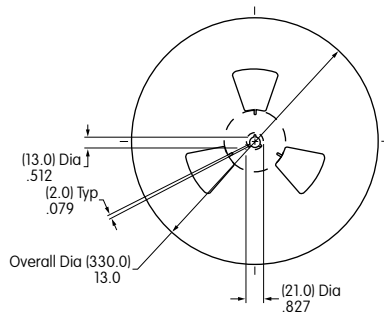

KEYBOARD MATRIX

Common Bus Matrix

These single pole, single throw switches can be used in a keyboard matrix and, using strapped terminals, achieve a common bus electrical configuration on a single-sided PC board.

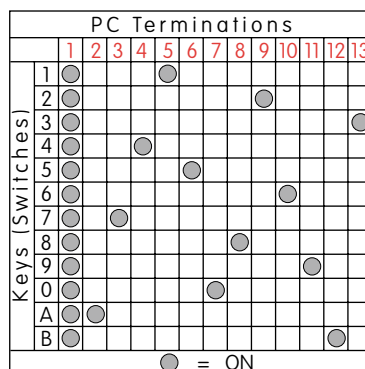
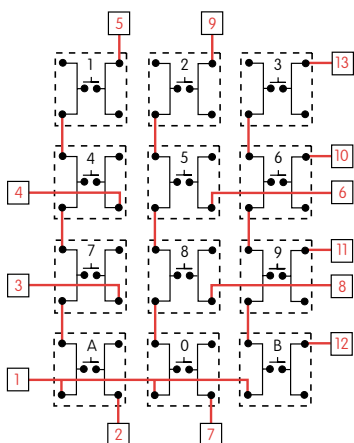

X-Y Matrix

These single pole, single throw switches can be arranged on a single-sided PC board matrix with strapped terminals to achieve an X-Y type electrical interconnection.

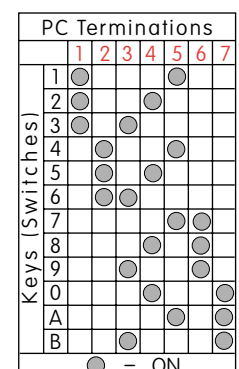
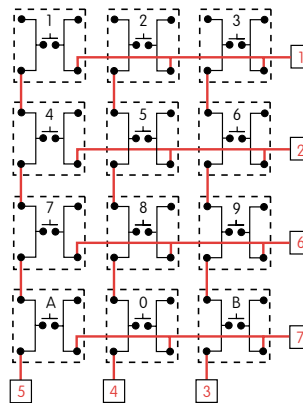

Red = PCB Trace Black = Switch Circuit

Toggles
Rockers
Pushbuttons
Illuminated PB
Programmable
Keylocks
Rotaries
Slides
Tactiles
Tilt
Touch
Indicators
Accessories
Supplement

Компания «Life Electronics» занимается поставками электронных компонентов импортного и отечественного производства от производителей и со складов крупных дистрибьюторов Европы, Америки и Азии.

С конца 2013 года компания активно расширяет линейку поставок компонентов по направлению коаксиальный кабель, кварцевые генераторы и конденсаторы (керамические, пленочные, электролитические), за счёт заключения дистрибьюторских договоров

Мы предлагаем:

- Конкурентоспособные цены и скидки постоянным клиентам.
- Специальные условия для постоянных клиентов.
- Подбор аналогов.
- Поставку компонентов в любых объемах, удовлетворяющих вашим потребностям.
- Приемлемые сроки поставки, возможна ускоренная поставка.
- Доставку товара в любую точку России и стран СНГ.
- Комплексную поставку.
- Работу по проектам и поставку образцов.
- Формирование склада под заказчика.
- Сертификаты соответствия на поставляемую продукцию (по желанию клиента).
- Тестирование поставляемой продукции.
- Поставку компонентов, требующих военную и космическую приемку.
- Входной контроль качества.
- Наличие сертификата ISO.

В составе нашей компании организован Конструкторский отдел, призванный помогать разработчикам, и инженерам.

Конструкторский отдел помогает осуществить:

- Регистрацию проекта у производителя компонентов.
- Техническую поддержку проекта.
- Защиту от снятия компонента с производства.
- Оценку стоимости проекта по компонентам.
- Изготовление тестовой платы монтаж и пусконаладочные работы.



Тел: +7 (812) 336 43 04 (многоканальный)
Email: org@lifeelectronics.ru