

TIMER

■ GENERAL DESCRIPTION

The NJM555 monolithic timing circuit is a highly stable controller capable of producing accurate time delays or oscillation. In the time delay mode, delay time is precisely controlled by only two external parts: a resistor and a capacitor. For operation as an oscillator, both the free running frequency and the duty cycle are accurately controlled by two external resistors and a capacitor.

Terminals are provided for triggering and resetting. The circuit will trigger and reset on falling waveforms. The output can source or sink up to 200mA or drive TTL circuits.

■ FEATURES

- Operating Voltage (4.5V ~ 16V)
- Less Number of External Components
- Package Outline DIP8, DMP8, SSOP8, SIP8
- Bipolar Technology

■ PACKAGE OUTLINE

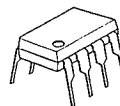

NJM555D



NJM555M

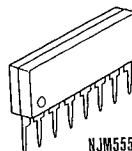

NJM555L



NJM555V

■ PIN CONFIGURATION

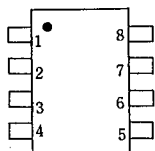

NJM555D  
NJM555M  
NJM555V

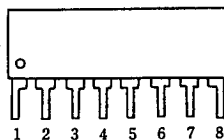

NJM555L

PIN FUNCTION

1. GND
2. Trigger
3. Output
4. Reset
5. Control Voltage
6. Threshold
7. Discharge
8. V<sup>+</sup>

■ EQUIVALENT CIRCUIT

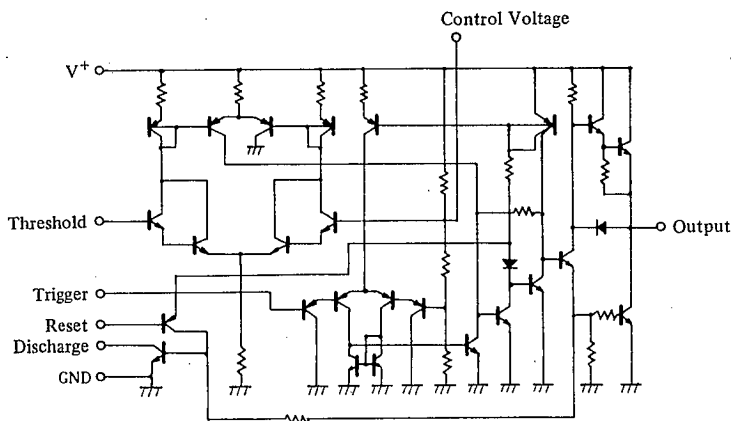

## ■ ABSOLUTE MAXIMUM RATINGS

(Ta=25°C)

PARAMETER	SYMBOL	RATINGS	UNIT
Supply Voltage	V <sup>+</sup>	18	V
Power Dissipation	P <sub>d</sub>	(DIP8) 500	mW
		(DMP8) 300	mW
		(SSOP8) 250	mW
		(SIP8) 800	mW
Operating Temperature Range	T <sub>opr</sub>	-40~+85	°C
Storage Temperature Range	T <sub>stg</sub>	-40~+125	°C

## ■ ELECTRICAL CHARACTERISTICS

(V<sup>+</sup>=5~15V, Ta=25°C)

PARAMETER	SYMBOL	TEST CONDITION	MIN.	TYP.	MAX.	UNIT
Operating Voltage	V <sup>+</sup>		4.5	—	16	V
Operating Current (Note 1)	I <sub>cc</sub>	V <sup>+</sup> =5V, R <sub>L</sub> =∞	—	3.0	6.0	mA
Operating Current (Note 1)	I <sub>cc</sub>	V <sup>+</sup> =15V, R <sub>L</sub> =∞	—	10	15	mA
Timing Error (Note 2)						
Initial Accuracy	E <sub>t</sub>	Ta=-20~75°C, V <sup>+</sup> =5~15V	—	1.0	—	%
Drift with Temperature	E <sub>t</sub>	Ta=-20~75°C, V <sup>+</sup> =5~15V	—	50	—	ppm/°C
Drift with Supply Voltage	E <sub>t</sub>	Ta=-20~75°C, V <sup>+</sup> =5~15V	—	0.1	—	%/V
Threshold Voltage	V <sub>th</sub>		—	2/3	—	×V <sup>+</sup>
Trigger Voltage	V <sub>T</sub>	V <sup>+</sup> =15V	—	5.0	—	V
Trigger Voltage	V <sub>T</sub>	V <sup>+</sup> =5V	—	1.67	—	V
Trigger Current	I <sub>T</sub>		—	0.5	—	μA
Reset Voltage	V <sub>R</sub>		0.4	0.5	1.0	V
Reset Current	I <sub>R</sub>		—	0.1	—	mA
Threshold Current	I <sub>th</sub>		—	0.1	0.25	μA
Control Voltage Level	V <sub>CL</sub>	V <sup>+</sup> =15V	9	10	11	V
Control Voltage Level	V <sub>CL</sub>	V <sup>+</sup> =5V	2.6	3.33	4.0	V
Output Voltage (Low)	V <sub>OL</sub>	V <sup>+</sup> =15V I <sub>sink</sub> =10mA	—	0.1	0.25	V
Output Voltage (Low)	V <sub>OL</sub>	V <sup>+</sup> =15V I <sub>sink</sub> =50mA	—	0.4	0.75	V
Output Voltage (Low)	V <sub>OL</sub>	V <sup>+</sup> =15V I <sub>sink</sub> =100mA (Note 3)	—	2.0	2.5	V
Output Voltage (Low)	V <sub>OL</sub>	V <sup>+</sup> =15V I <sub>sink</sub> =200mA (Note 3)	—	2.5	—	V
Output Voltage (Low)	V <sub>OL</sub>	V <sup>+</sup> =5V I <sub>sink</sub> =5mA	—	0.25	0.35	V
Output Voltage (High)	V <sub>OHI</sub>	V <sup>+</sup> =15V I <sub>source</sub> =200mA (Note 3)	—	12.5	—	V
Output Voltage (High)	V <sub>OHI</sub>	V <sup>+</sup> =15V I <sub>source</sub> =100mA (Note 3)	12.75	13.3	—	V
Output Voltage (High)	V <sub>OHI</sub>	V <sup>+</sup> =15V I <sub>source</sub> =40mA	—	13.5	—	V
Output Voltage (High)	V <sub>OHI</sub>	V <sup>+</sup> =5V I <sub>source</sub> =100mA	2.75	3.3	—	V
Rise Time of Output	t <sub>r</sub>	No Loading	—	100	—	ns
Fall Time of Output	t <sub>f</sub>	No Loading	—	100	—	ns

Note 1: Low output condition (When the output is high, it is lower than the low output condition by 1mA in the standard specification.)

Note 2: R<sub>A</sub>, R<sub>B</sub>=1k~100kΩ, C=0.1μF, V<sup>+</sup>=15V from 5V

Note 3: Not specified for NJM555M/NJM555E

## ■ TYPICAL APPLICATION

### (1) 50% Duty Cycle Oscillator

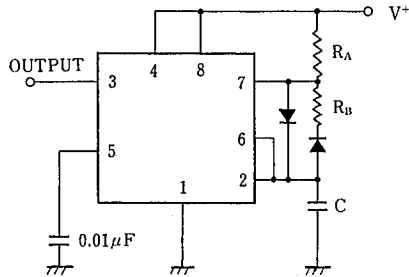

Duty cycle 50% at  $R_A = R_B$   
 Due to  $R_A, R_B$  value  
 the duty ratio becomes  
 lower than 50%.

### (2) Oscillation frequency can be changed by changing the control voltage.

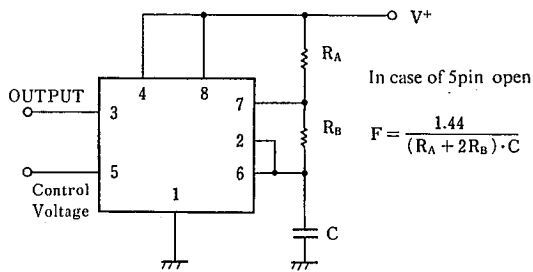

In case of 5pin open

$$F = \frac{1.44}{(R_A + 2R_B) \cdot C}$$

### (3) Pulse Width Modulation

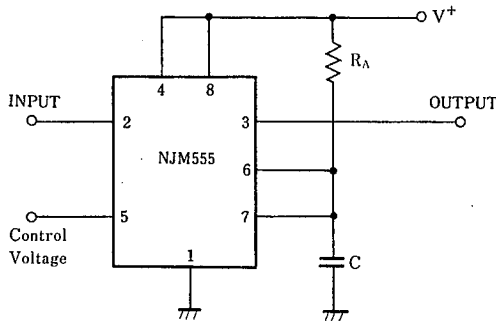

6

■ TYPICAL CHARACTERISTICS

Operating Current vs. Operating Voltage  
( $V_{out} = \text{LOW STATE}$ )

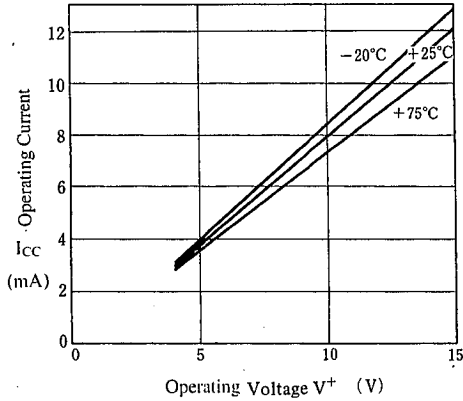

Delay Time vs. Operating Voltage  
( $T_a = 25^\circ\text{C}$ )

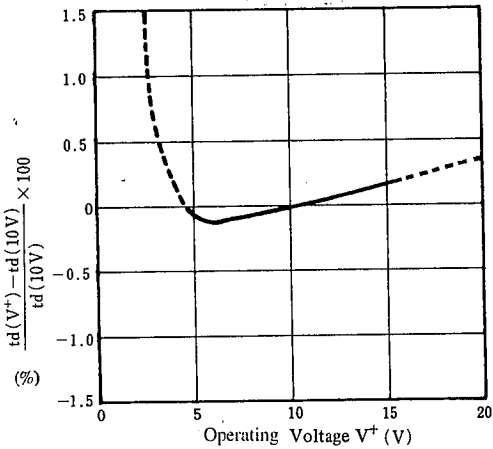

Low Output Voltage vs. Output Sink Current ( $V^+ = 5\text{V}$ )

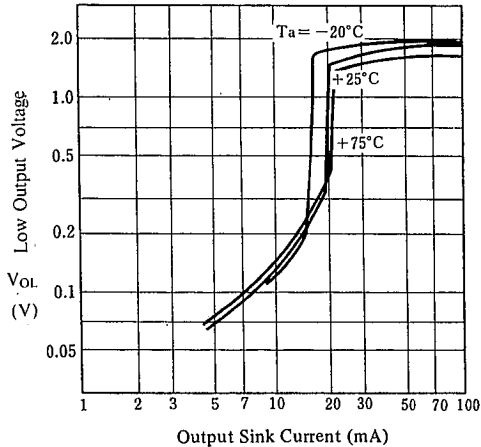

Delay Time vs. Temperature  
( $V^+ = 10\text{V}$ )

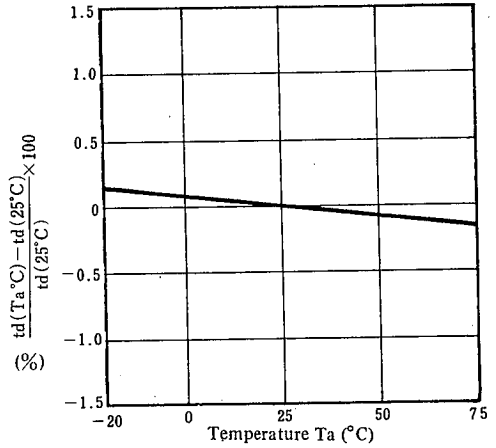

High Output Voltage Drop vs. Output Source Current  
( $5\text{V} \leq V^+ \leq 15\text{V}$ )

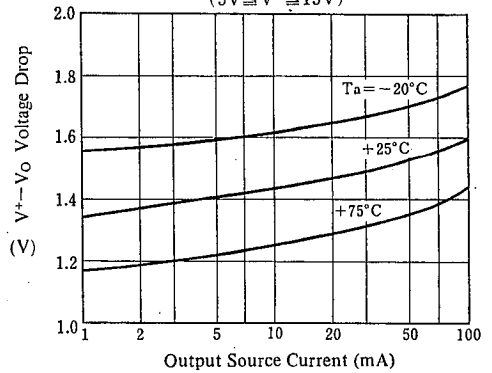

Low Output Voltage vs. Output Sink Current ( $V^+ = 15\text{V}$ )

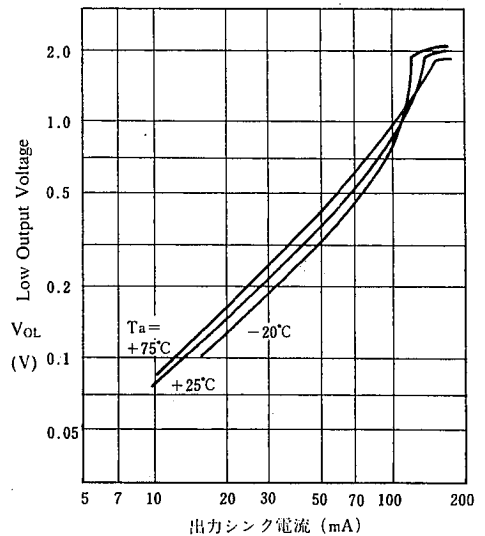

6

■ TYPICAL CHARACTERISTICS

1. Monostable Operation

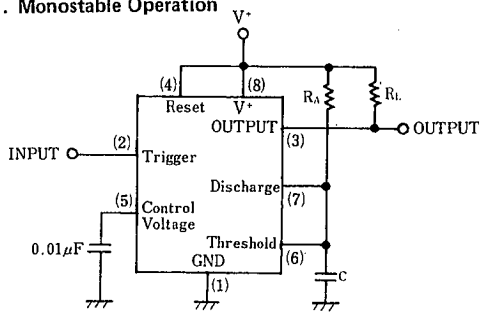

Fig. 1

2. Free Running Operation

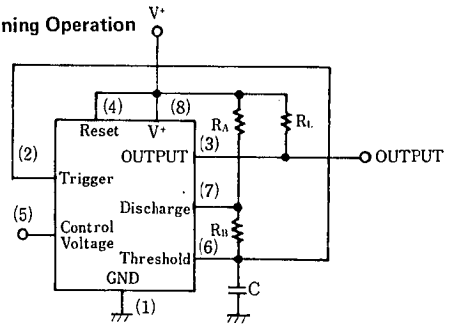

Fig. 3

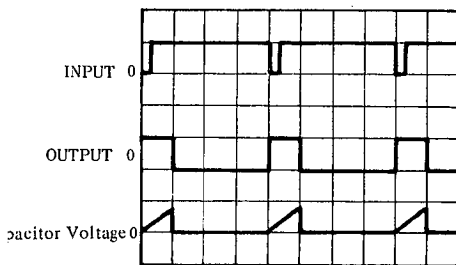

Fig.2 Wave Form

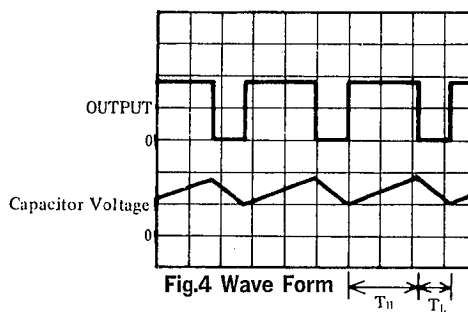
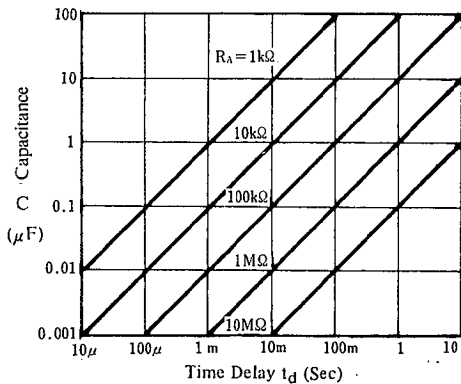
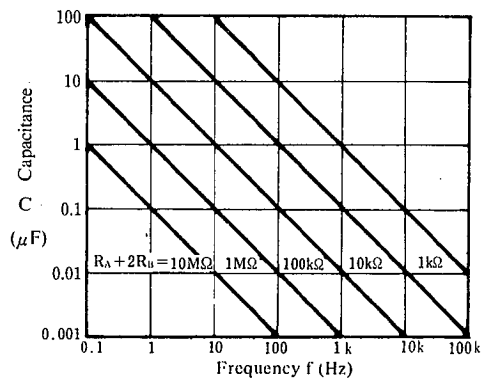

Fig.4 Wave Form



Time Delay vs.  $R_A$ ,  $R_B$  and  $C$

Fig. 2 shows a typical example of the monostable operation.  $T_H = 1.1R_A \cdot C$  assuming that  $T_H$  be the time at the high output level in this figure.



Free Running Frequency vs.  $R_A$ ,  $R_B$  and  $C$

Fig. 4 shows a typical example of the free running operation.

The charge time (output High) is given by:

$$T_H = 0.693 (R_A + R_B) \cdot C$$

And the discharge time (output Low) by:

$$T_L = 0.693 R_B \cdot C$$

The frequency of oscillation is:

$$F = \frac{1.44}{(R_A + 2R_B) \cdot C}$$

The duty cycle is:

$$D = \frac{T_H}{T_H + T_L} = \frac{R_A + R_B}{R_A + 2R_B}$$

## MEMO

**[CAUTION]**

The specifications on this databook are only given for information, without any guarantee as regards either mistakes or omissions. The application circuits in this databook are described only to show representative usages of the product and not intended for the guarantee or permission of any right including the industrial rights.

Компания «Life Electronics» занимается поставками электронных компонентов импортного и отечественного производства от производителей и со складов крупных дистрибьюторов Европы, Америки и Азии.

С конца 2013 года компания активно расширяет линейку поставок компонентов по направлению коаксиальный кабель, кварцевые генераторы и конденсаторы (керамические, пленочные, электролитические), за счёт заключения дистрибьюторских договоров

Мы предлагаем:

- Конкурентоспособные цены и скидки постоянным клиентам.
- Специальные условия для постоянных клиентов.
- Подбор аналогов.
- Поставку компонентов в любых объемах, удовлетворяющих вашим потребностям.
- Приемлемые сроки поставки, возможна ускоренная поставка.
- Доставку товара в любую точку России и стран СНГ.
- Комплексную поставку.
- Работу по проектам и поставку образцов.
- Формирование склада под заказчика.
- Сертификаты соответствия на поставляемую продукцию (по желанию клиента).
- Тестирование поставляемой продукции.
- Поставку компонентов, требующих военную и космическую приемку.
- Входной контроль качества.
- Наличие сертификата ISO.

В составе нашей компании организован Конструкторский отдел, призванный помогать разработчикам, и инженерам.

Конструкторский отдел помогает осуществить:

- Регистрацию проекта у производителя компонентов.
- Техническую поддержку проекта.
- Защиту от снятия компонента с производства.
- Оценку стоимости проекта по компонентам.
- Изготовление тестовой платы монтаж и пусконаладочные работы.



Тел: +7 (812) 336 43 04 (многоканальный)

Email: [org@lifeelectronics.ru](mailto:org@lifeelectronics.ru)