

Right Angle 2.0mm Pitch Connector

9155-700



AVX extends their board-to-board right angle connectors with a new 2mm pitch version 9155-700, an addition to the existing versions 9155-300 with a 3mm pitch and 9155-500 with a 2.5mm pitch. This new connector is offered in 2 to 6 contact positions and rated at 2 Amps for the 2-4 way versions or 1.5 Amps for the 5-6 way versions. The connector's design is small and compact in order to minimize its profile, yet remain stable while having a contact point at 2.10mm above the PCB.

The stability comes from extra SMT anchor brackets. In addition to existing versions, the new connector has two options without or with locating bosses, providing even better mechanical stability on the PCB.

The complete family of connectors 9155 series from AVX offer all the same advantages : Ultra reliable and robust gold plated beryllium copper contacts provide high integrity connections in harsh environments, with 5000 mating operations, high temperature nylon plastic for RoHS soldering.

APPLICATIONS

- Handheld/portable devices requiring docking or cradle charging
- Patient monitoring or portable medical electronics
- Industrial devices requiring pluggable or programming modules
- Internet appliances requiring battery back-up

FEATURES AND BENEFITS

- Simple designed compact 2mm pitch right angle connector up to 6 positions
- Gold plated BeCu contacts provide high electrical and mechanical performance over 5000 mating cycles
- Two anchor brackets for mechanical stability
- Optional plastic locating bosses with SMT anchor tabs maximizes the mechanical stability of the connector in harsh conditions

ELECTRICAL

- Current Rating: 2p-4p: 2.0 Amps, 5p-6p: 1.5 Amps
- Voltage Rating: 125 VAC

ENVIRONMENTAL

- Operating Temperature: -40°C to +125°C

MECHANICAL

- Insulator Material: Glass-Filled Nylon 46; UL94V0
- Contact Material: Beryllium Copper
- Plating: Gold over Nickel, Tin leads
- Durability: 5000 Cycles

HOW TO ORDER

00
Prefix

9155
Series

00X
No of Ways

Code	No of Ways	Qty Per Reel	
		Without Boss	With Boss
002	2	1000	1000
003	3	1000	1000
004	4	1000	1000
005	5	1000	1000
006	6	1000	1000

7XX
Standard Battery Connector

Code	Description	Operating Height	Boss
741	Battery Connector Right Angle	4.00mm	No
742	Battery Connector Right Angle	4.00mm	Yes

00

X

Plating Option

- 6 = 0.4µm Selective Gold, Pure Tin Tail
- 8 = 0.8µm Selective Gold, Pure Tin Tail

Right Angle 2.0mm Pitch Connector

9155-700



2 WAY BATTERY CONNECTOR – RIGHT ANGLE 2MM PITCH – WITHOUT BOSS

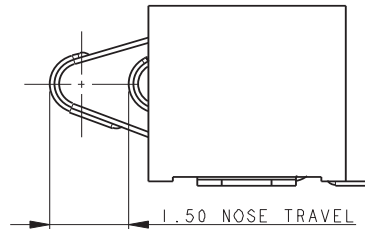
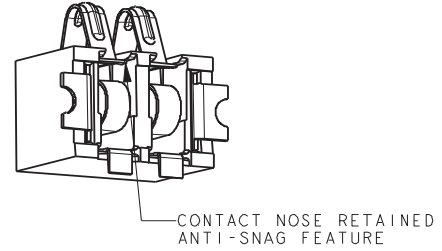
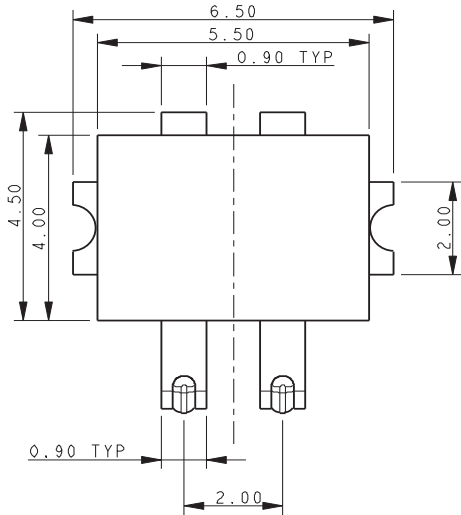

DEFLECTED CONNECTOR

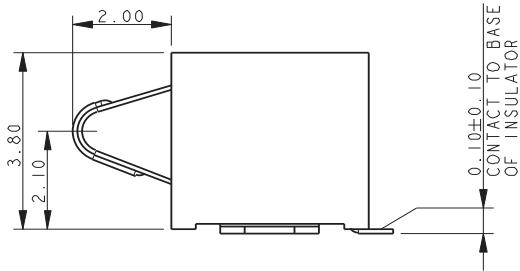
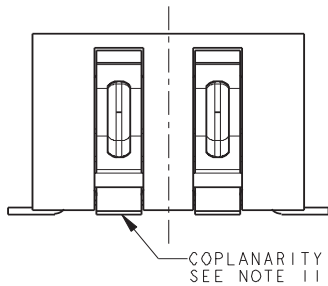

UNDEFLECTED CONTACT

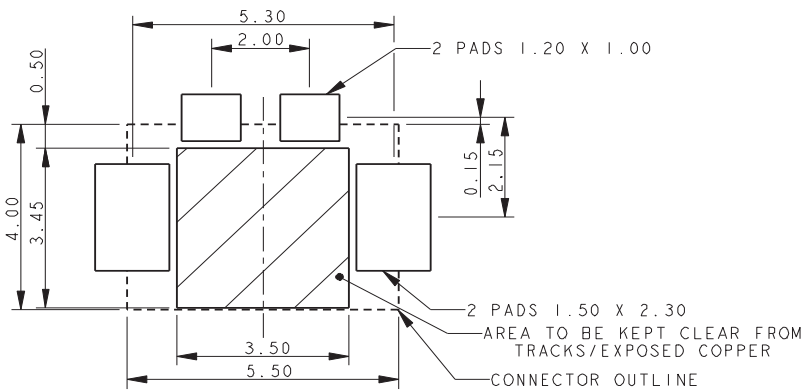

SUGGESTED PCB LAYOUT

NOTES:

1. GENERAL TOLERANCE ± 0.20 UNLESS OTHERWISE STATED.
2. FOR FULL PRODUCT SPECIFICATION REFER TO AVX SPEC 201-01-203.
3. FOR MATING PAD DETAILS REFER TO PAGE 13.
4. PACKING DETAILS ON PAGE 12.
5. INSULATOR MATERIAL: GLASS FILLED NYLON 46, UL94 V-0, COLOR BLACK.
6. CONTACT MATERIAL: BERYLLIUM COPPER.
7. CONTACT PLATING; SELECTIVE GOLD OVER NICKEL, PURE TIN ON TAILS.
8. BRACKET MATERIAL; PHOSPHOR BRONZE.
9. BRACKET PLATING; PURE TIN OVER NICKEL.
10. NOMINAL CONTACT FORCE 90 GRAMS AT 1.50 DEFLECTION.
11. COPLANARITY OF ALL CONTACT TAILS AND PADS 0.10MM MAXIMUM.

Right Angle 2.0mm Pitch Connector

9155-700

2 WAY BATTERY CONNECTOR – RIGHT ANGLE 2MM PITCH – WITH BOSS

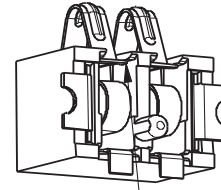
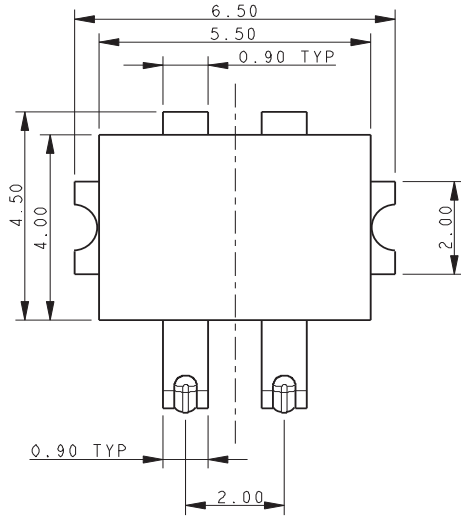

CONTACT NOSE RETAINED
ANTI-SNAG FEATURE

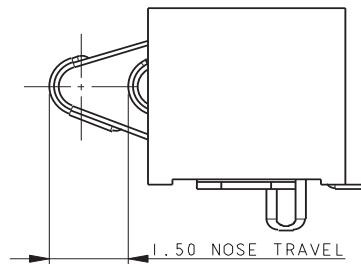

DEFLECTED CONNECTOR

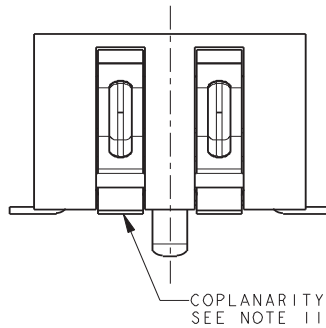

COPLANARITY
SEE NOTE 11

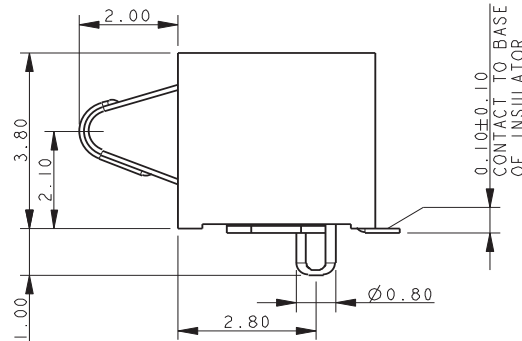

UNDEFLECTED CONTACT

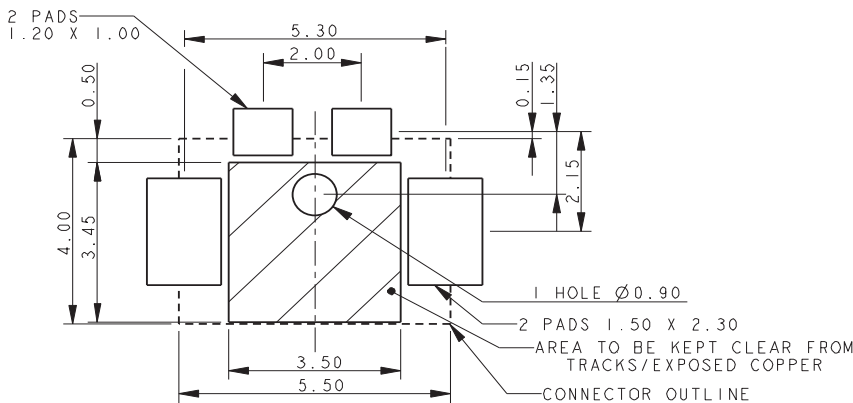

SUGGESTED PCB LAYOUT

NOTES:

1. GENERAL TOLERANCE ± 0.20 UNLESS OTHERWISE STATED.
2. FOR FULL PRODUCT SPECIFICATION REFER TO AVX SPEC 201-01-203.
3. FOR MATING PAD DETAILS REFER TO PAGE 13.
4. PACKING DETAILS ON PAGE 12.
5. INSULATOR MATERIAL: GLASS FILLED NYLON 46, UL94 V-0, COLOR BLACK.
6. CONTACT MATERIAL: BERYLLIUM COPPER.
7. CONTACT PLATING; SELECTIVE GOLD OVER NICKEL, PURE TIN ON TAILS.
8. BRACKET MATERIAL; PHOSPHOR BRONZE.
9. BRACKET PLATING; PURE TIN OVER NICKEL.
10. NOMINAL CONTACT FORCE 90 GRAMS AT 1.50 DEFLECTION.
11. COPLANARITY OF ALL CONTACT TAILS AND PADS 0.10MM MAXIMUM.

Right Angle 2.0mm Pitch Connector

9155-700



3 WAY BATTERY CONNECTOR – RIGHT ANGLE 2MM PITCH – WITHOUT BOSS

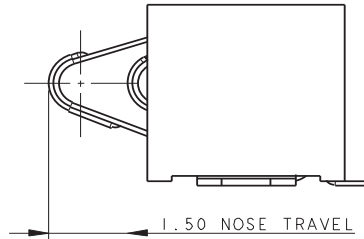
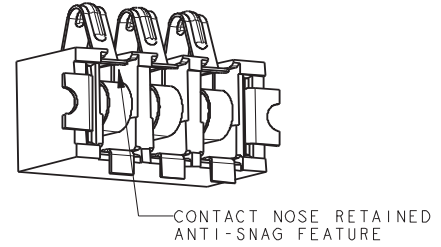
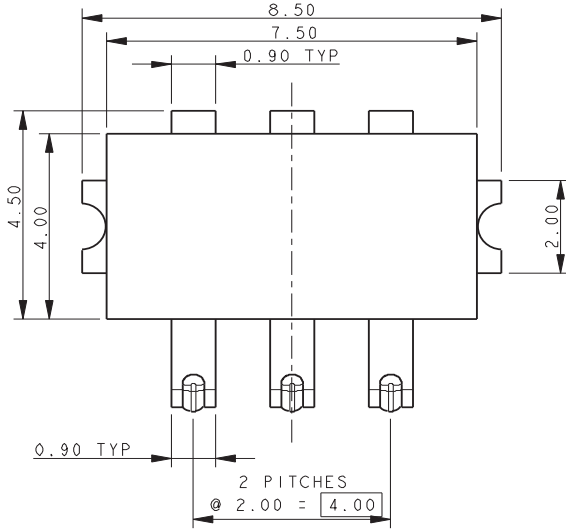

DEFLECTED CONNECTOR

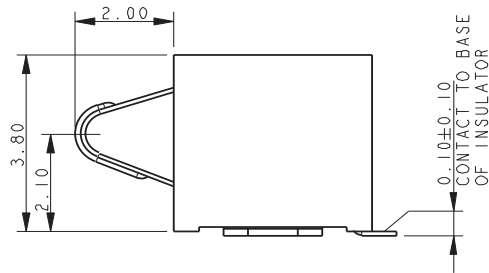
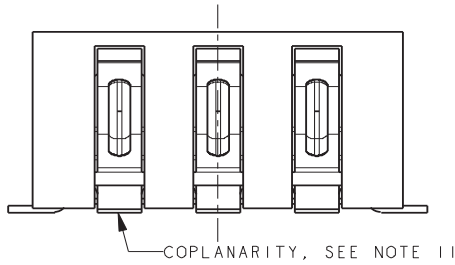

UNDEFLECTED CONTACT

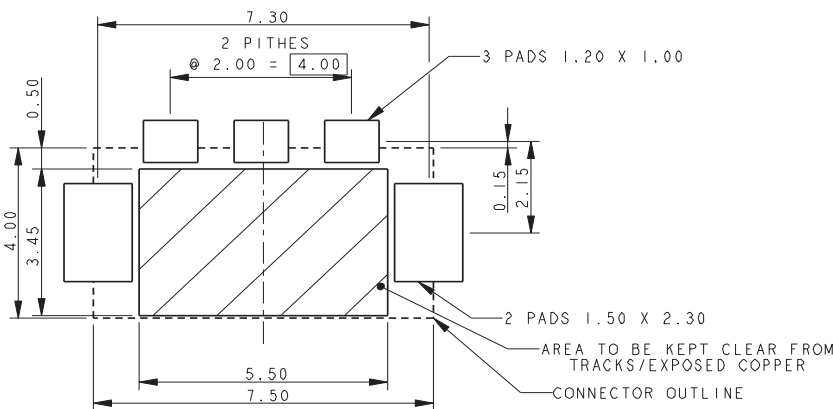

SUGGESTED PCB LAYOUT

NOTES:

1. GENERAL TOLERANCE ± 0.20 UNLESS OTHERWISE STATED.
2. FOR FULL PRODUCT SPECIFICATION REFER TO AVX SPEC 201-01-203.
3. FOR MATING PAD DETAILS REFER TO PAGE 13.
4. PACKING DETAILS ON PAGE 12.
5. INSULATOR MATERIAL: GLASS FILLED NYLON 46, UL94 V-0, COLOR BLACK.
6. CONTACT MATERIAL: BERYLLIUM COPPER.
7. CONTACT PLATING; SELECTIVE GOLD OVER NICKEL, PURE TIN ON TAILS.
8. BRACKET MATERIAL; PHOSPHOR BRONZE.
9. BRACKET PLATING; PURE TIN OVER NICKEL.
10. NOMINAL CONTACT FORCE 90 GRAMS AT 1.50 DEFLECTION.
11. COPLANARITY OF ALL CONTACT TAILS AND PADS 0.10MM MAXIMUM.

Right Angle 2.0mm Pitch Connector

9155-700



3 WAY BATTERY CONNECTOR – RIGHT ANGLE 2MM PITCH – WITH BOSS

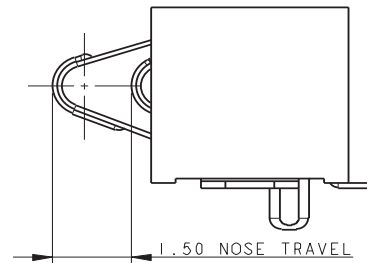
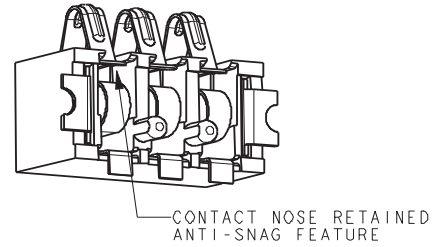
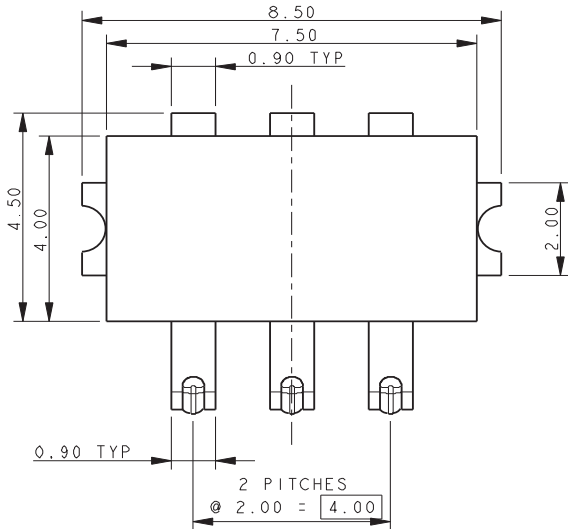

DEFLECTED CONNECTOR

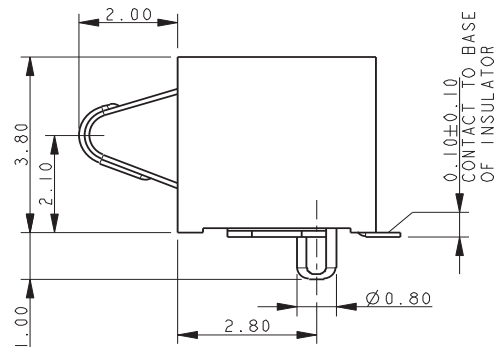
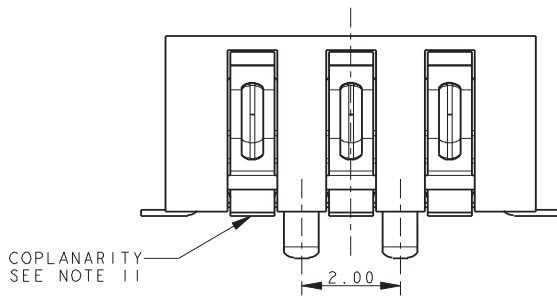

UNDEFLECTED CONTACT

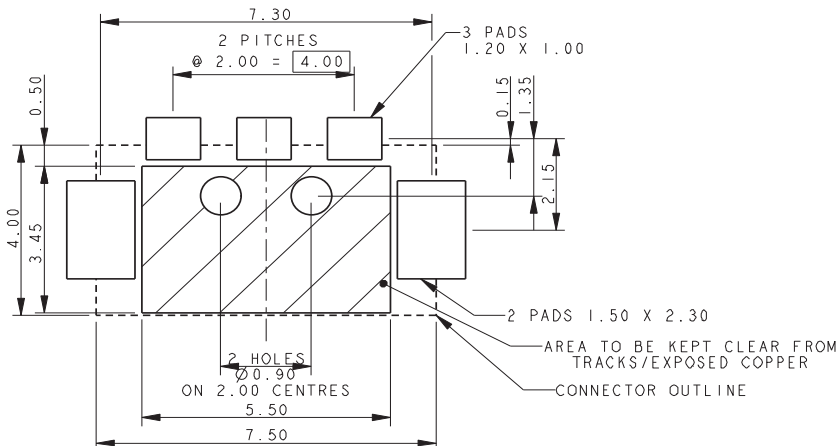

SUGGESTED PCB LAYOUT

NOTES:

1. GENERAL TOLERANCE ± 0.20 UNLESS OTHERWISE STATED.
2. FOR FULL PRODUCT SPECIFICATION REFER TO AVX SPEC 201-01-203.
3. FOR MATING PAD DETAILS REFER TO PAGE 13.
4. PACKING DETAILS ON PAGE 12.
5. INSULATOR MATERIAL: GLASS FILLED NYLON 46, UL94 V-0, COLOR BLACK.
6. CONTACT MATERIAL: BERYLLIUM COPPER.
7. CONTACT PLATING; SELECTIVE GOLD OVER NICKEL, PURE TIN ON TAILS.
8. BRACKET MATERIAL; PHOSPHOR BRONZE.
9. BRACKET PLATING; PURE TIN OVER NICKEL.
10. NOMINAL CONTACT FORCE 90 GRAMS AT 1.50 DEFLECTION.
11. COPLANARITY OF ALL CONTACT TAILS AND PADS 0.10MM MAXIMUM.

Right Angle 2.0mm Pitch Connector

9155-700

4 WAY BATTERY CONNECTOR – RIGHT ANGLE 2MM PITCH – WITHOUT BOSS

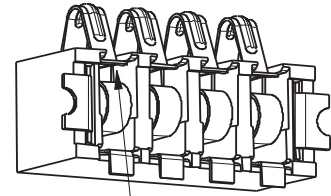
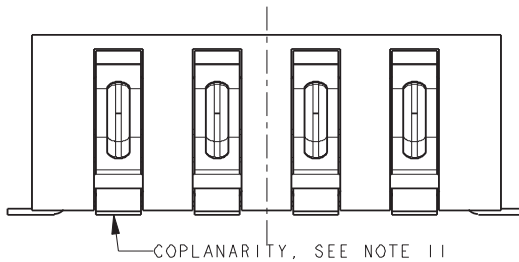
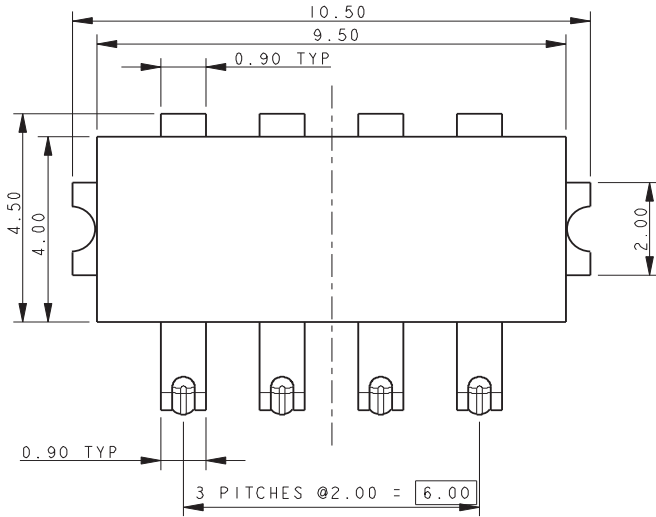

CONTACT NOSE RETAINED ANTI-SNAG FEATURE

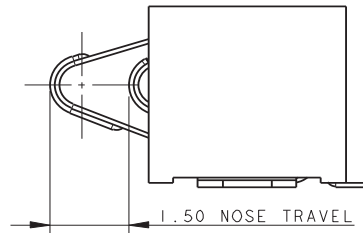

DEFLECTED CONNECTOR

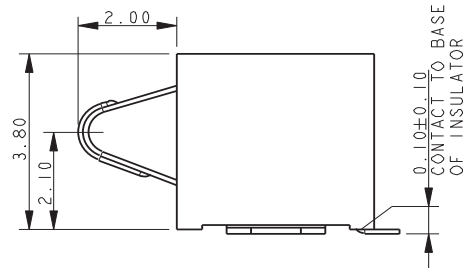

UNDEFLECTED CONTACT

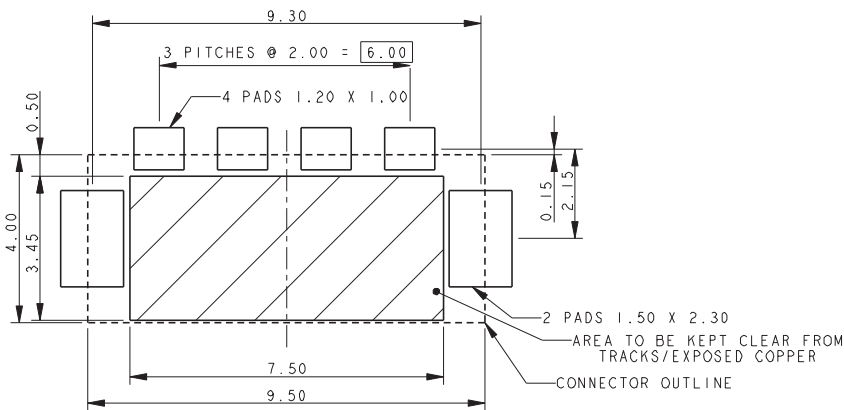

SUGGESTED PCB LAYOUT

NOTES:

1. GENERAL TOLERANCE ± 0.20 UNLESS OTHERWISE STATED.
2. FOR FULL PRODUCT SPECIFICATION REFER TO AVX SPEC 201-01-203.
3. FOR MATING PAD DETAILS REFER TO PAGE 13.
4. PACKING DETAILS ON PAGE 12.
5. INSULATOR MATERIAL: GLASS FILLED NYLON 46, UL94 V-0, COLOR BLACK.
6. CONTACT MATERIAL: BERYLLIUM COPPER.
7. CONTACT PLATING; SELECTIVE GOLD OVER NICKEL, PURE TIN ON TAILS.
8. BRACKET MATERIAL; PHOSPHOR BRONZE.
9. BRACKET PLATING; PURE TIN OVER NICKEL.
10. NOMINAL CONTACT FORCE 90 GRAMS AT 1.50 DEFLECTION.
11. COPLANARITY OF ALL CONTACT TAILS AND PADS 0.10MM MAXIMUM.

Right Angle 2.0mm Pitch Connector

9155-700



4 WAY BATTERY CONNECTOR – RIGHT ANGLE 2MM PITCH – WITH BOSS

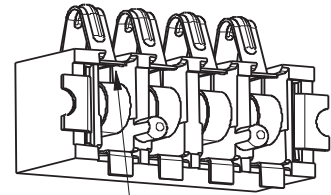
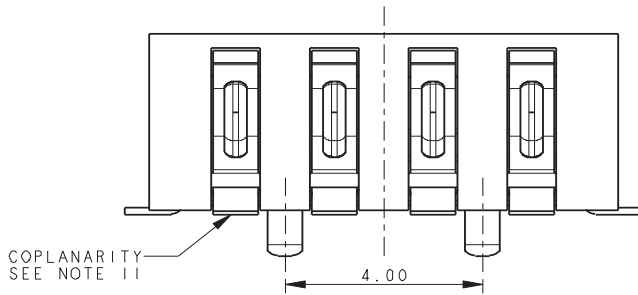
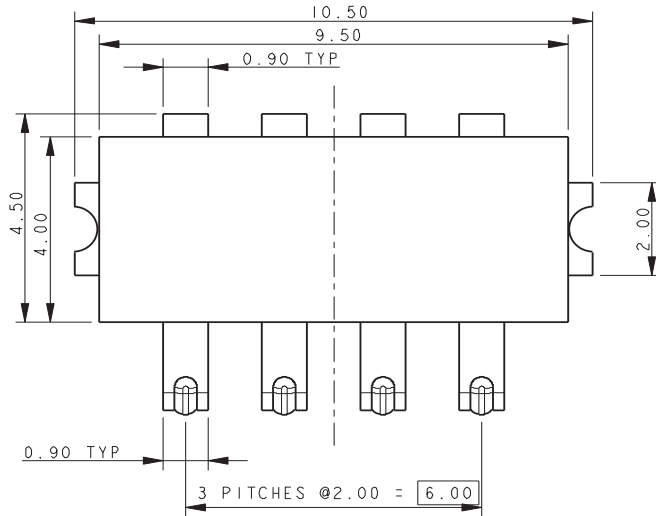

CONTACT NOSE RETAINED ANTI-SNAG FEATURE

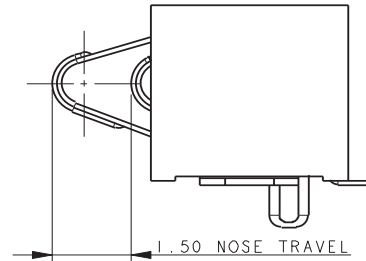

DEFLECTED CONNECTOR

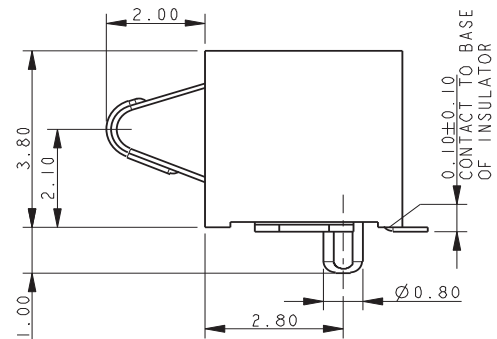

UNDEFLECTED CONTACT

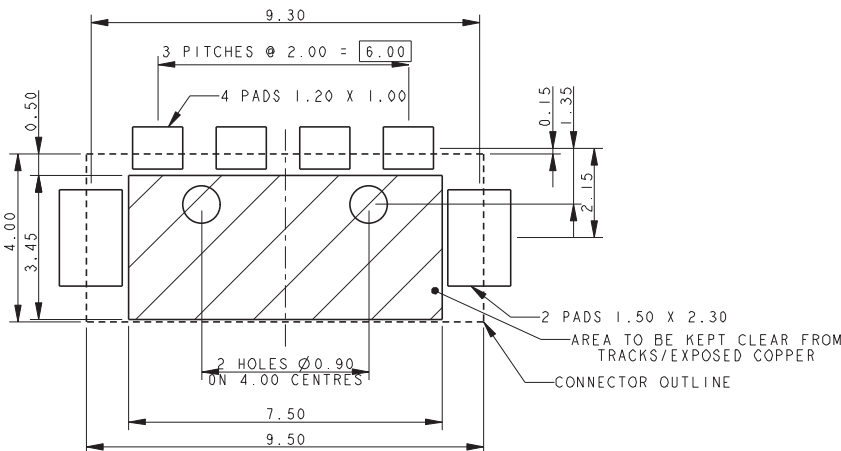

SUGGESTED PCB LAYOUT

NOTES:

1. GENERAL TOLERANCE ± 0.20 UNLESS OTHERWISE STATED.
2. FOR FULL PRODUCT SPECIFICATION REFER TO AVX SPEC 201-01-203.
3. FOR MATING PAD DETAILS REFER TO PAGE 13.
4. PACKING DETAILS ON PAGE 12.
5. INSULATOR MATERIAL: GLASS FILLED NYLON 46, UL94 V-0, COLOR BLACK.
6. CONTACT MATERIAL: BERYLLIUM COPPER.
7. CONTACT PLATING; SELECTIVE GOLD OVER NICKEL, PURE TIN ON TAILS.
8. BRACKET MATERIAL; PHOSPHOR BRONZE.
9. BRACKET PLATING; PURE TIN OVER NICKEL.
10. NOMINAL CONTACT FORCE 90 GRAMS AT 1.50 DEFLECTION.
11. COPLANARITY OF ALL CONTACT TAILS AND PADS 0.10MM MAXIMUM.

Right Angle 2.0mm Pitch Connector

9155-700



5 WAY BATTERY CONNECTOR – RIGHT ANGLE 2MM PITCH – WITHOUT BOSS

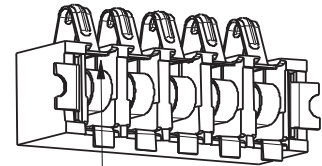
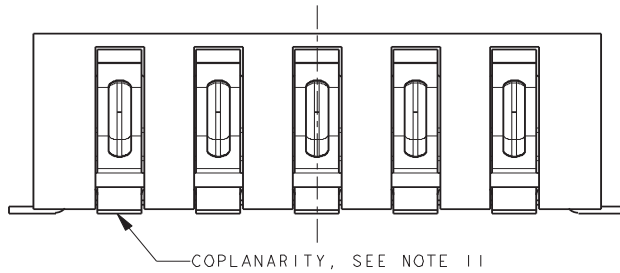
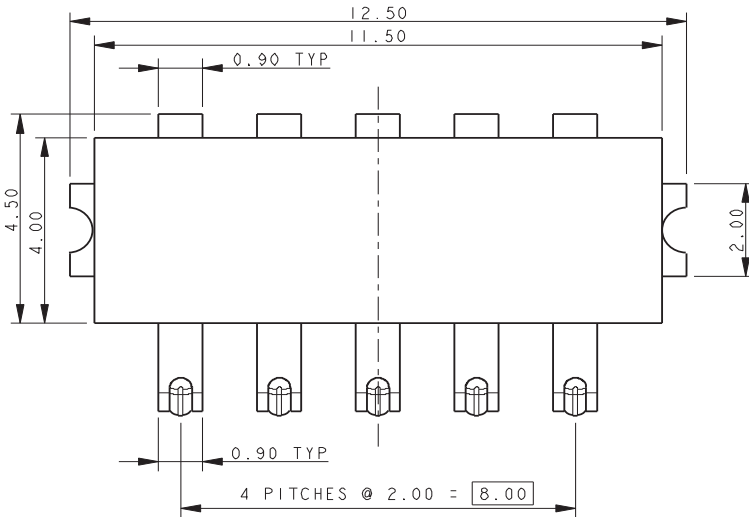

CONTACT NOSE RETAINED
ANTI-SNAG FEATURE

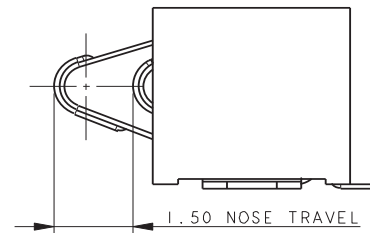

DEFLECTED CONNECTOR

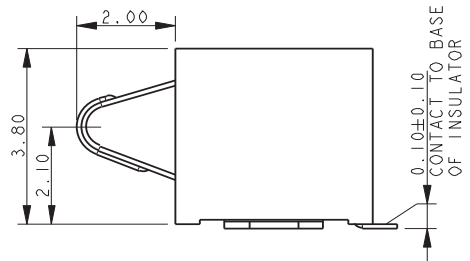

UNDEFLECTED CONTACT

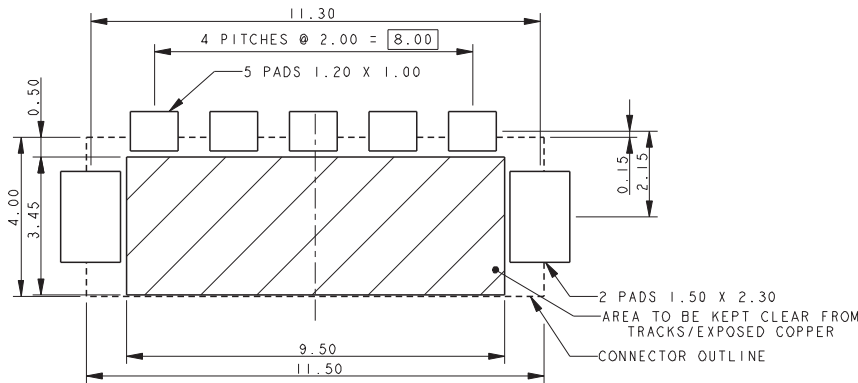

SUGGESTED PCB LAYOUT

NOTES:

1. GENERAL TOLERANCE ± 0.20 UNLESS OTHERWISE STATED.
2. FOR FULL PRODUCT SPECIFICATION REFER TO AVX SPEC 201-01-203.
3. FOR MATING PAD DETAILS REFER TO PAGE 13.
4. PACKING DETAILS ON PAGE 12.
5. INSULATOR MATERIAL: GLASS FILLED NYLON 46, UL94 V-0, COLOR BLACK.
6. CONTACT MATERIAL: BERYLLIUM COPPER.
7. CONTACT PLATING; SELECTIVE GOLD OVER NICKEL, PURE TIN ON TAILS.
8. BRACKET MATERIAL; PHOSPHOR BRONZE.
9. BRACKET PLATING; PURE TIN OVER NICKEL.
10. NOMINAL CONTACT FORCE 90 GRAMS AT 1.50 DEFLECTION.
11. COPLANARITY OF ALL CONTACT TAILS AND PADS 0.12MM MAXIMUM.

Right Angle 2.0mm Pitch Connector

9155-700

5 WAY BATTERY CONNECTOR – RIGHT ANGLE 2MM PITCH – WITH BOSS

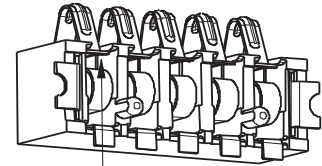
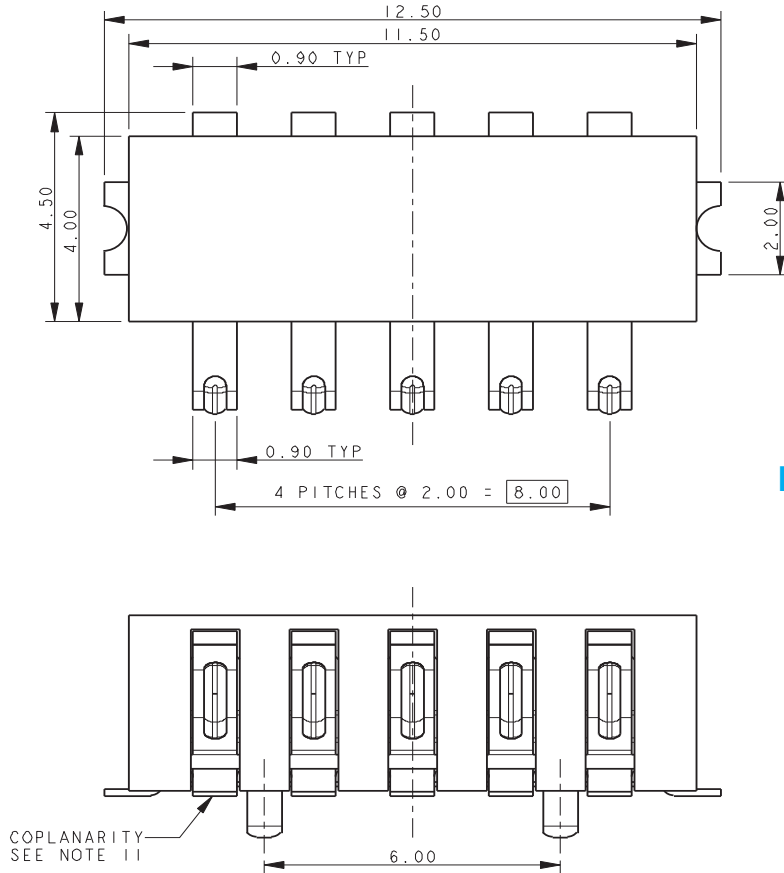

CONTACT NOSE RETAINED ANTI-SNAG FEATURE

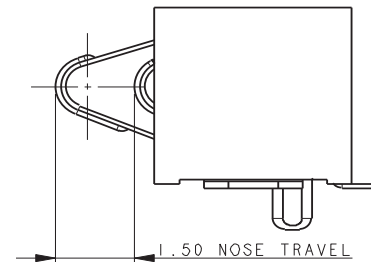

DEFLECTED CONNECTOR

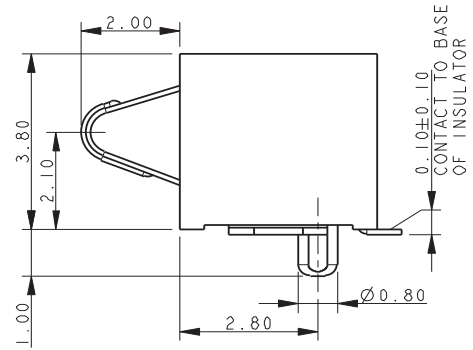

UNDEFLECTED CONTACT

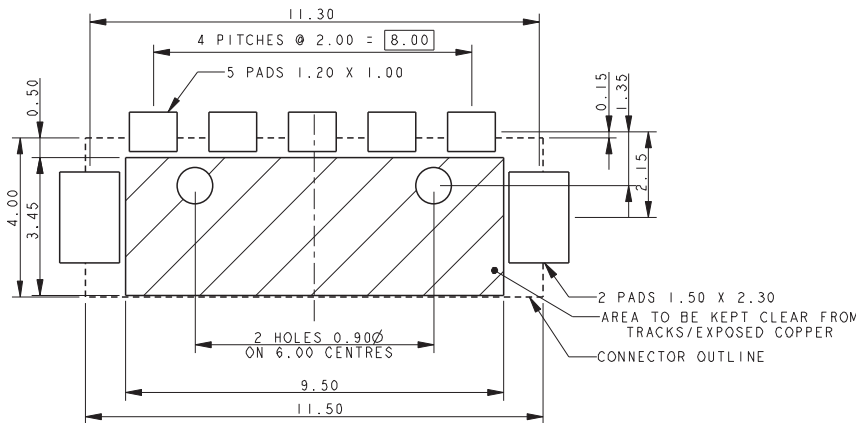

SUGGESTED PCB LAYOUT

NOTES:

1. GENERAL TOLERANCE ± 0.20 UNLESS OTHERWISE STATED.
2. FOR FULL PRODUCT SPECIFICATION REFER TO AVX SPEC 201-01-203.
3. FOR MATING PAD DETAILS REFER TO PAGE 13.
4. PACKING DETAILS ON PAGE 12.
5. INSULATOR MATERIAL: GLASS FILLED NYLON 46, UL94 V-0, COLOR BLACK.
6. CONTACT MATERIAL: BERYLLIUM COPPER.
7. CONTACT PLATING; SELECTIVE GOLD OVER NICKEL, PURE TIN ON TAILS.
8. BRACKET MATERIAL; PHOSPHOR BRONZE.
9. BRACKET PLATING; PURE TIN OVER NICKEL.
10. NOMINAL CONTACT FORCE 90 GRAMS AT 1.50 DEFLECTION.
11. COPLANARITY OF ALL CONTACT TAILS AND PADS 0.12MM MAXIMUM.

Right Angle 2.0mm Pitch Connector

9155-700

6 WAY BATTERY CONNECTOR – RIGHT ANGLE 2MM PITCH – WITHOUT BOSS

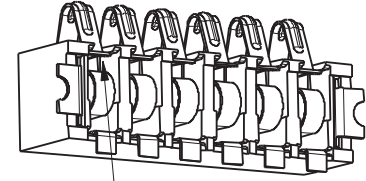
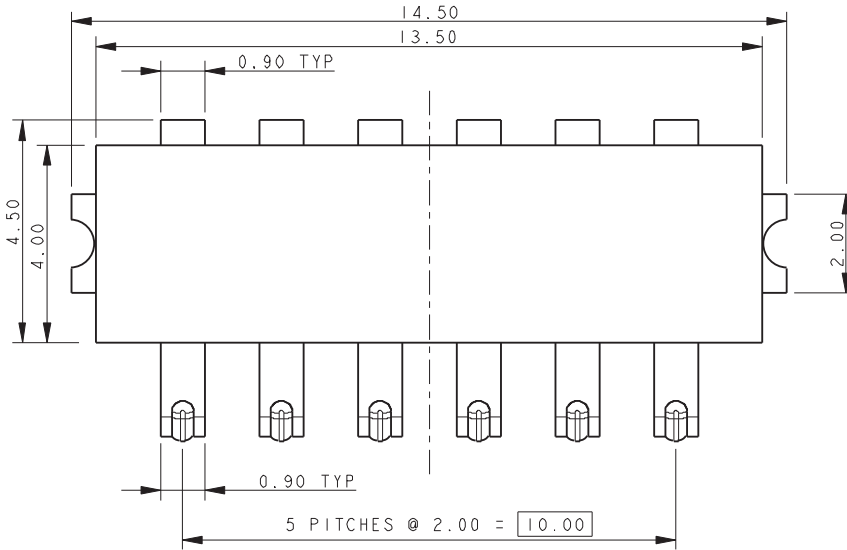

CONTACT NOSE RETAINED ANTI-SNAG FEATURE

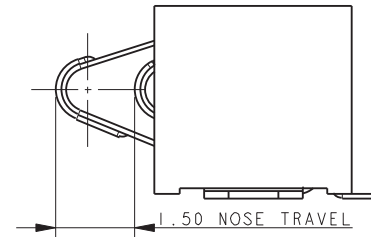

DEFLECTED CONNECTOR

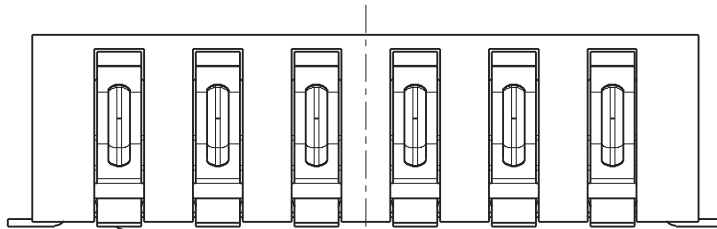

COPLANARITY SEE NOTE 11

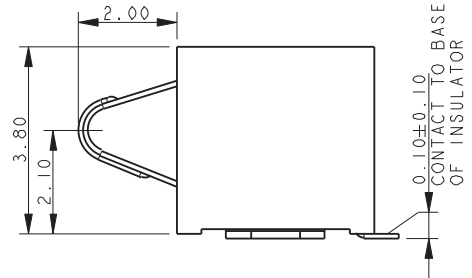

UNDEFLECTED CONTACT

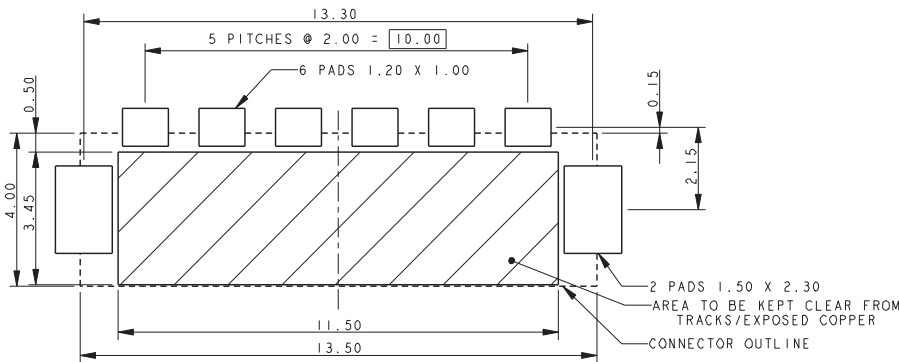

SUGGESTED PCB LAYOUT

NOTES:

1. GENERAL TOLERANCE ± 0.20 UNLESS OTHERWISE STATED.
2. FOR FULL PRODUCT SPECIFICATION REFER TO AVX SPEC 201-01-203.
3. FOR MATING PAD DETAILS REFER TO PAGE 13.
4. PACKING DETAILS ON PAGE 12.
5. INSULATOR MATERIAL: GLASS FILLED NYLON 46, UL94 V-0, COLOR BLACK.
6. CONTACT MATERIAL: BERYLLIUM COPPER.
7. CONTACT PLATING; SELECTIVE GOLD OVER NICKEL, PURE TIN ON TAILS.
8. BRACKET MATERIAL; PHOSPHOR BRONZE.
9. BRACKET PLATING; PURE TIN OVER NICKEL.
10. NOMINAL CONTACT FORCE 90 GRAMS AT 1.50 DEFLECTION.
11. COPLANARITY OF ALL CONTACT TAILS AND PADS 0.12MM MAXIMUM.

Right Angle 2.0mm Pitch Connector

9155-700

6 WAY BATTERY CONNECTOR – RIGHT ANGLE 2MM PITCH – WITH BOSS

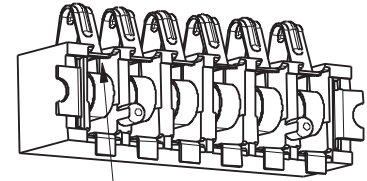
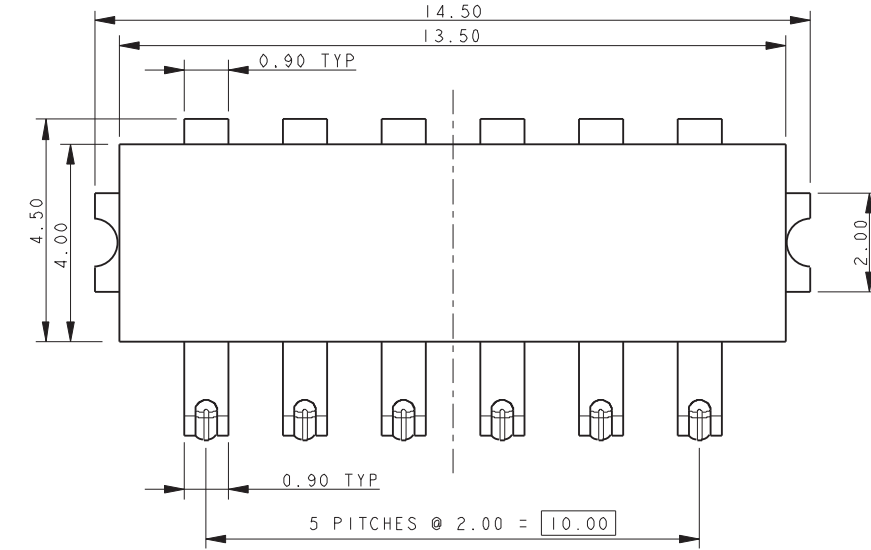

CONTACT NOSE RETAINED
ANTI-SLAG FEATURE

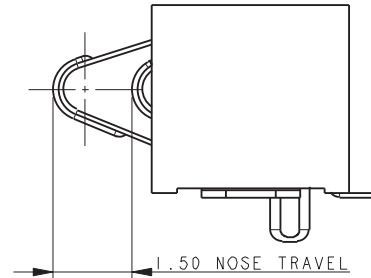

DEFLECTED CONNECTOR

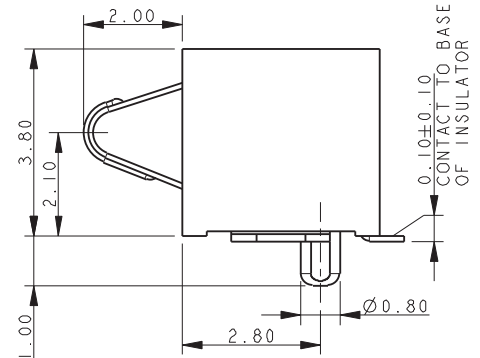
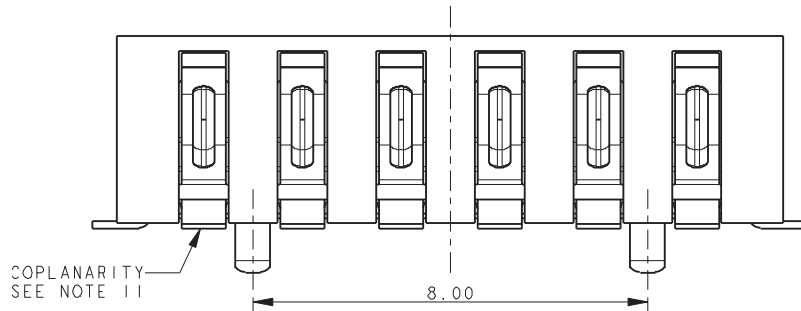

UNDEFLECTED CONTACT

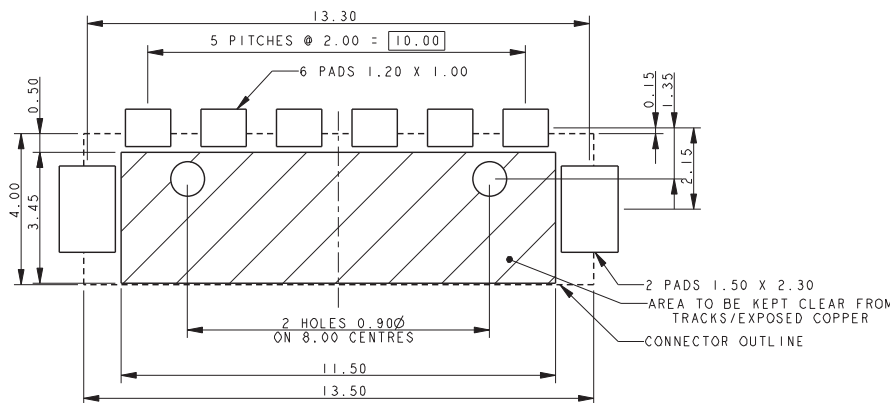

SUGGESTED PCB LAYOUT

NOTES:

1. GENERAL TOLERANCE ± 0.20 UNLESS OTHERWISE STATED.
2. FOR FULL PRODUCT SPECIFICATION REFER TO AVX SPEC 201-01-203.
3. FOR MATING PAD DETAILS REFER TO PAGE 13.
4. PACKING DETAILS ON PAGE 12.
5. INSULATOR MATERIAL: GLASS FILLED NYLON 46, UL94 V-0, COLOR BLACK.
6. CONTACT MATERIAL: BERYLLIUM COPPER.
7. CONTACT PLATING; SELECTIVE GOLD OVER NICKEL, PURE TIN ON TAILS.
8. BRACKET MATERIAL; PHOSPHOR BRONZE.
9. BRACKET PLATING; PURE TIN OVER NICKEL.
10. NOMINAL CONTACT FORCE 90 GRAMS AT 1.50 DEFLECTION.
11. COPLANARITY OF ALL CONTACT TAILS AND PADS 0.12MM MAXIMUM.

Right Angle 2.0mm Pitch Connector

9155-700

PACKING DETAILS

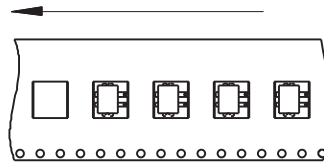
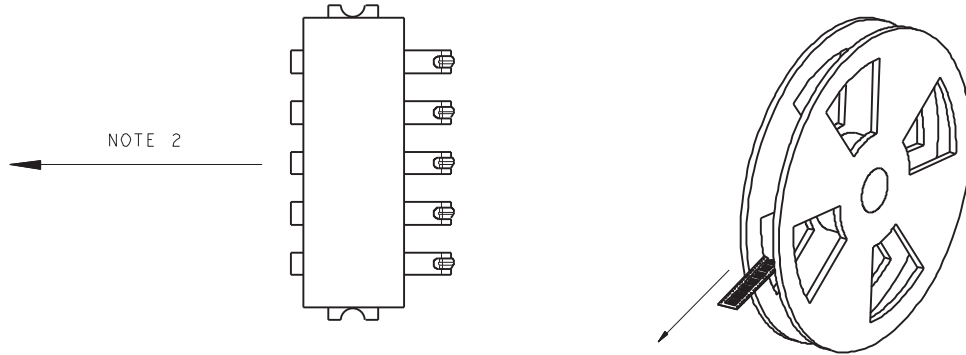

No of Ways	2
REEL QTY	1000 without Boss 1000 with Boss
TAPE WIDTH	24mm
POCKET PITCH	12mm

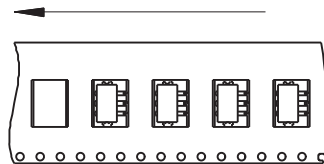

No of Ways	3
REEL QTY	1000 without Boss 1000 with Boss
TAPE WIDTH	24mm
POCKET PITCH	12mm

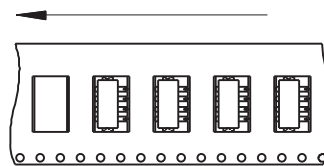

No of Ways	4
REEL QTY	1000 without Boss 1000 with Boss
TAPE WIDTH	24mm
POCKET PITCH	12mm

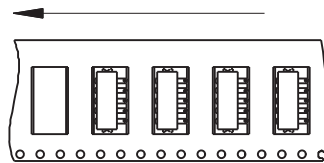

No of Ways	5
REEL QTY	1000 without Boss 1000 with Boss
TAPE WIDTH	24mm
POCKET PITCH	12mm

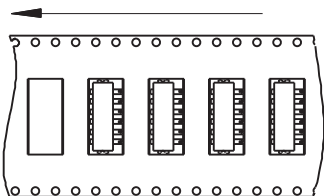

No of Ways	6
REEL QTY	1000 without Boss 1000 with Boss
TAPE WIDTH	32mm
POCKET PITCH	12mm

- NOTES:
1. PARTS TO BE PACKED ON 330MM REELS.
2. COMPONENT ORIENTATION SHOWN.

2MM PITCH RIGHT ANGLE – MATING PADS

2 WAY – MATING PADS

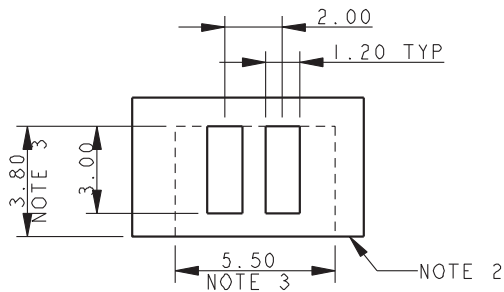

3 WAY – MATING PADS

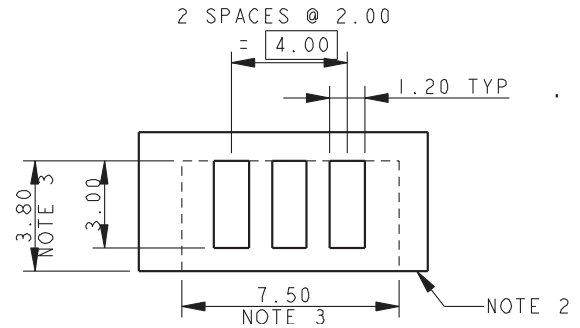

4 WAY – MATING PADS

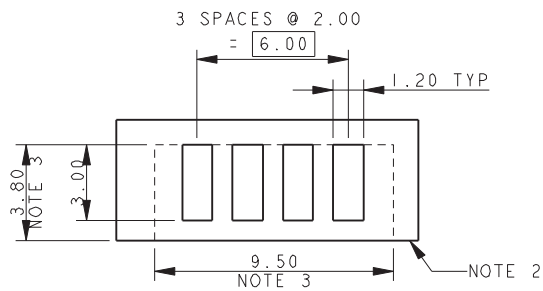

5 WAY – MATING PADS

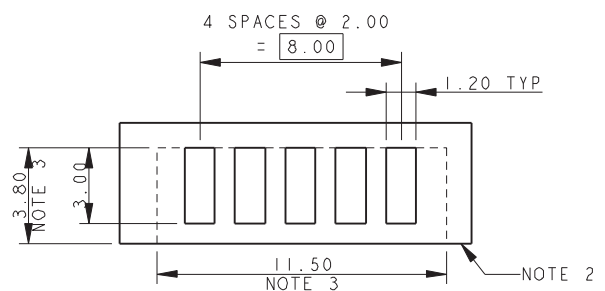

6 WAY – MATING PADS

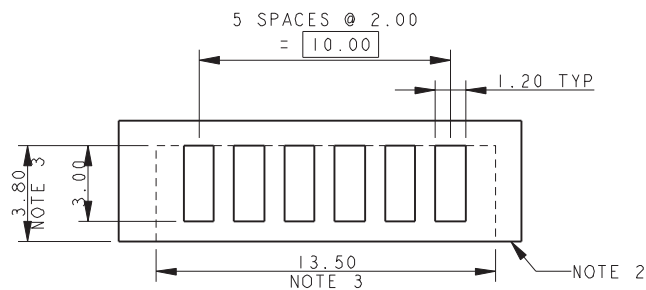

NOTES:

1. SUGGESTED MATING PADS FOR RIGHT ANGLE BATTERY CONNECTORS.
2. TOP SURFACE OF HORIZONTAL PCB/BASE OF CONNECTOR.
3. PREFERRED PLATING ON PADS, GOLD OVER NICKEL.

Компания «Life Electronics» занимается поставками электронных компонентов импортного и отечественного производства от производителей и со складов крупных дистрибьюторов Европы, Америки и Азии.

С конца 2013 года компания активно расширяет линейку поставок компонентов по направлению коаксиальный кабель, кварцевые генераторы и конденсаторы (керамические, пленочные, электролитические), за счёт заключения дистрибьюторских договоров

Мы предлагаем:

- Конкурентоспособные цены и скидки постоянным клиентам.
- Специальные условия для постоянных клиентов.
- Подбор аналогов.
- Поставку компонентов в любых объемах, удовлетворяющих вашим потребностям.
- Приемлемые сроки поставки, возможна ускоренная поставка.
- Доставку товара в любую точку России и стран СНГ.
- Комплексную поставку.
- Работу по проектам и поставку образцов.
- Формирование склада под заказчика.
- Сертификаты соответствия на поставляемую продукцию (по желанию клиента).
- Тестирование поставляемой продукции.
- Поставку компонентов, требующих военную и космическую приемку.
- Входной контроль качества.
- Наличие сертификата ISO.

В составе нашей компании организован Конструкторский отдел, призванный помогать разработчикам, и инженерам.

Конструкторский отдел помогает осуществить:

- Регистрацию проекта у производителя компонентов.
- Техническую поддержку проекта.
- Защиту от снятия компонента с производства.
- Оценку стоимости проекта по компонентам.
- Изготовление тестовой платы монтаж и пусконаладочные работы.



Тел: +7 (812) 336 43 04 (многоканальный)

Email: org@lifeelectronics.ru