



SPRING-LOADED SOLDERLESS CONTACT

AlphaLink PC Board Connectors and Jumpers

BOARD-LEVEL SOLUTIONS FOR MISSION-CRITICAL APPLICATIONS

OCTOBER 2013

SERIES 171

AlphaLink



Discrete connectors and turnkey I/O to board flex and wire jumpers for high-performance applications—shielded, rugged, high-temperature, spring-loaded, solderless.



AlphaLink is an innovative high-performance printed circuit board connector built on .050" center-to-center contact spacing with spring-loaded board contacts and flex, wire, or solder cup terminations. Spring-loaded contacts interconnect directly to board pads and circuits to effect an ultra-low-profile and lightweight solution. Direct connection to the board eliminates a mating connector half and makes for easier and faster board preparation and masking. On the termination side, AlphaLink connectors are equipped with either PC tail, pre-terminated wire pigtailed, or solder cups for complete versatility in flex circuit or conventional wire termination. AlphaLink may be ordered as a discrete connector or in turnkey jumper configurations paired with Glenair I/O connectors, including Series 80 Mighty Mouse, Series 88 SuperFly, Series 79 Micro-Crimp™, Series 89 circular and rectangular Nanominiature, and our mil-qualified 83513 (MWDM) Micro-D connectors.



Glenair, Inc.
1211 Air Way
Glendale, CA
91201-2497
818-247-6000
sales@glenair.com
www.glenair.com

AlphaLink SL spring-loaded printed circuit board connectors and flex / wire jumpers

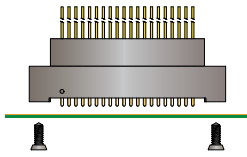

INTRODUCTION

Product overview • performance specifications.....pg. 2

A



ALPHALINK SL SPRING-LOADED PRINTED CIRCUIT BOARD CONNECTORS

Contact arrangements, PCB layouts and technical specs.....pg. 4
171-134-01 AlphaLink SL connector with spring loaded contacts and solder cupspg. 5
171-134-02 AlphaLink SL connector with spring loaded contacts and PC tails.....pg. 6
171-134-03 AlphaLink SL connector with spring loaded contacts and pigtail wires.....pg. 7

B



NANO CIRCULAR / ALPHALINK JUMPERS

Contact arrangements, materials and finishes, dimensions, PCB layout, panel cutout..... pg. 10
893-012 Circular Nano breakaway rear-panel-mount receptacle to AlphaLink SL flex jumper..... pg. 12
893-013 Circular Nano threaded rear-panel-mount receptacle to AlphaLink SL flex jumper..... pg. 14

C

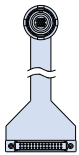

SUPERFLY™ / ALPHALINK JUMPERS

Contact arrangements, materials and finishes, dimensions, PCB layout, panel cutout..... pg. 16
880-034 SuperFly QDC rear-panel-mount receptacle to AlphaLink SL flex jumper pg. 18
881-021 SuperFly threaded rear-panel-mount receptacle to AlphaLink SL flex jumper..... pg. 20

D

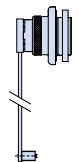

MIGHTY MOUSE / ALPHALINK JUMPERS

Contact arrangements, materials and finishes, dimensions, alternate key positions pg. 22
801-110 Mighty Mouse double-start ACME thread rear-panel-mount connector to AlphaLink SL flex jumper..... pg. 24
804-110 Mighty Mouse push-pull rear-panel-mount connector to AlphaLink SL flex jumper pg. 26

E

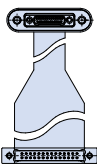

NANO RECTANGULAR / ALPHALINK JUMPERS

891-041 Contact arrangements, materials and finishes, how to orderpgs. 28 – 29
891-041 Rectangular Nanominiature Plug dimensions pg. 30
891-041 Rectangular Nanominiature Receptacle dimensions..... pg. 31

F

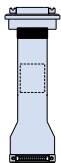

MICRO-D / ALPHALINK JUMPERS

Contact arrangements, materials and finishes, hardware options, dimensions, PCB layout..... pg. 32
1770-2449 Rear panel mount Micro-D connector to AlphaLink SL flex jumper pg. 34

G

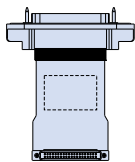

MICRO-CRIMP™ / ALPHALINK JUMPERS

Contact arrangements, hardware options, dimensions, PCB layout pg. 36
796-112 Rear panel mount Micro-Crimp™ pin contact receptacle to AlphaLink SL flex jumper..... pg. 38
796-113 Rear panel mount Micro-Crimp™ socket contact plug to AlphaLink SL flex jumper..... pg. 40

H



CUSTOM MICRO AND NANOMINIATURE FLEX SOLUTIONS

Build-to-print flex-circuit assembly capabilities..... pg. 44

J



SERIES 171

AlphaLink SL

Board-level spring-loaded-contact connectors and turnkey flex jumpers



AlphaLink SL is a high-performance, solderless board-level connector technology developed by Glenair that significantly expands board-level interconnection options for users of mil-spec caliber connectors. Precision-machined and EMI shielded, these ultralightweight PC tail, solder cup, and/or pigtail equipped connectors are designed for high-reliability applications that require avionic system levels of vibration and shock tolerance. Ultra low-profile and high-density, AlphaLink SL connectors are equipped with 2–3 Amp spring-loaded contacts and may be ordered either as discrete connectors or in turnkey flex jumpers that combine popular Glenair high-reliability I/O connectors. Glenair is perfectly positioned to provide the entire solution with in-house manufacturing for every component part—from connectors and contacts to rugged polyimide-based flex. AlphaLink SL flex jumpers are available with Series 80 Mighty Mouse, Series 88 SuperFly, and Series 89 nanominiature circular connectors, as well as Series 89 nanominiature, Micro-D subminiature and Series 79 Micro-Crimp rectangular connectors. A wide range of insert arrangements, from 4–40 contacts is available.

ALPHALINK ADVANTAGES

- **Spring-loaded, solderless board-level connector solution**
- **PC tail and solder cup versions offer easy termination to flex or wire**
- **Available turnkey I/O to board flex and pigtail wire jumpers**
- **Lightweight and low-profile—up to 40% space savings compared to 2mm pitch solutions**
- **High-density .050" center-to-center contact footprint**
- **Fast and easy PC board integration with reduced board preparation and masking**
- **Withstands temperature, vibration and shock extremes**



Flex offers many advantages over conventional wire, including reduced size, weight, and complexity

SERIES 171 ALPHALINK® SL

Spring-loaded board level connector

Design features



AlphaLink® SL Spring-Loaded Contact Interface

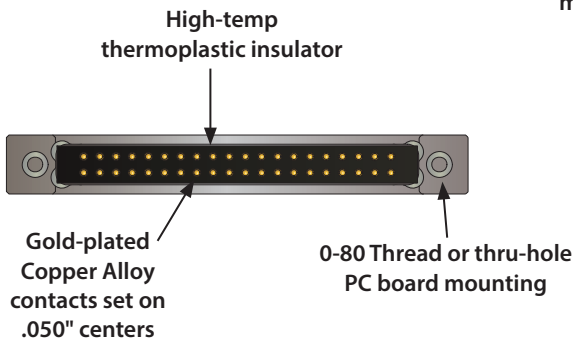

171-134-01 Solder Cup Termination

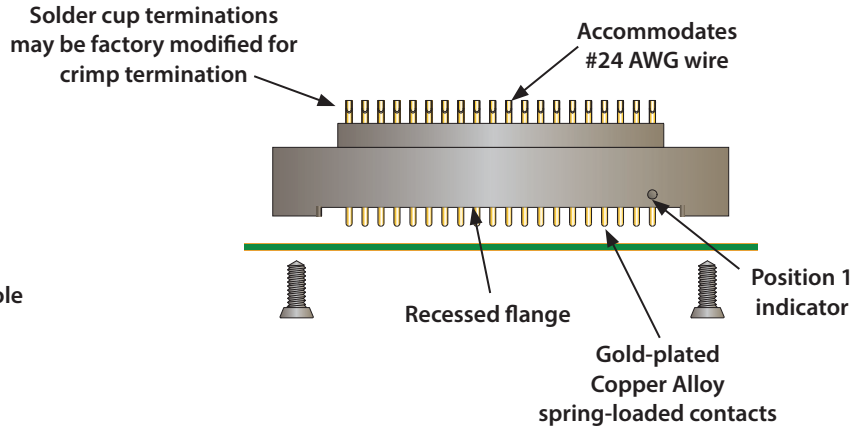

171-134-03 Wire Pigtail Termination

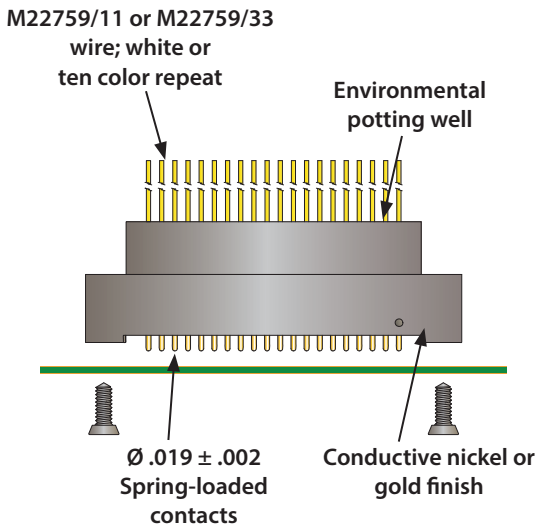

171-134-02 PC Tail Termination

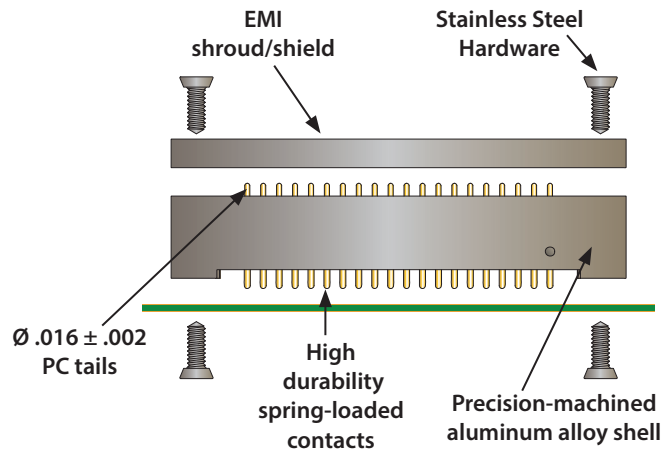

AlphaLink® SL flex jumpers: Compact interconnect assemblies that combine circuit board technology and cabling into a lightweight, integrated package. These turnkey jumper assemblies reduce system size and weight and are ideally suited for prototype applications and new product development efforts.

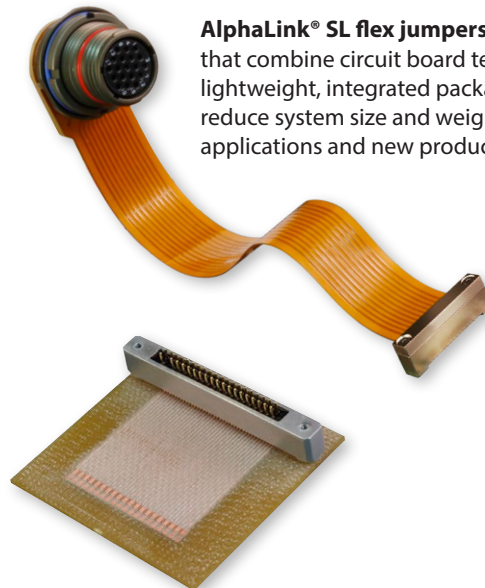

AlphaLink® SL spring-loaded contact PC board connectors deliver up to 50% footprint savings versus conventional 2mm pitch solutions. PC tail equipped connectors, the 171-134-02, are supplied with an EMI shroud / shield for improved EMC compared to low-cost plastic board connectors. All connector styles incorporate a high-reliability spring-loaded contact that delivers a virtually unlimited number of mating cycles. Connectors are typically mated to the PC board using conductive pads or via's. Stainless steel mounting hardware provides a robust, vibration-resistant attachment solution compared to stamped-and-formed retention barb.



For more information contact Glenair at **818-247-6000** or visit our website at **www.glenair.com**
U.S. CAGE code 06324

AlphaLink Available PCB Layouts (view from top of board)

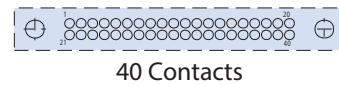
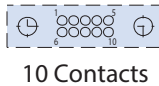

ALPHALINK® SPRING LOADED CONTACT CONNECTORS TECHNICAL SPECIFICATIONS

Modular contacts set on .050" centers, supplied in double-row contact arrangements. Precision-machined piston / base and gold-plated components assure a 1,000 minimum cycle life. Pistons have a .0275" mid stroke (when fully mated to PC board with a 60 gram/contact force.) Low resistance, high current contacts are rated at 2 amps continuous 3 amps peak. High temperature thermoplastic insulators are suitable for surface mount processes. Contact strips are designed for manual placement into $\varnothing.023 \pm .003$ " Plated thru-holes in the circuit board. Recommended for board thicknesses of .062" or greater.

Materials

Contact piston and base: machined Copper Alloy plated 20 micro inches Gold over 100 micro inches Nickel.
Spring: Beryllium Copper plated 10 micro inches Gold.
Insulator: high temp. thermoplastic rated UL94 V-0
Shell: Aluminum Alloy

Shell Finishes

Plating Code 2 = Electroless Nickel (Glenair M code, AMS-C-26074, Class 4 Grade B; ASTM-B-733, SC2, Type IV)
Plating Code 5 = Gold (Glenair code Z2, MIL-DTL-45204, Class 1 over Electroless Nickel)

Electrical

Voltage rating: 100vrms/150vdc
Current rating: 2A (continuous), 3A (peak) per contact.
Contact resistance: 20 milliohms maximum.
Insulation resistance: 5,000 megohms minimum.
Dielectric strength: 700 vrms minimum.
Capacitance: 1 pf maximum.

Mechanical

Spring force at initial height (a): 25 grams
Spring force at mid stroke (b/2): 60 grams
Durability: 1,000 cycles
Vibration sensitivity: 1.52mm DA or 20g. Duration 4h (in ea. Of 3 axis) per EIA-364-28D
Shock severity: 100g for 6ms per EIA-364-27B
Operational temperature: -65°C to +150°C

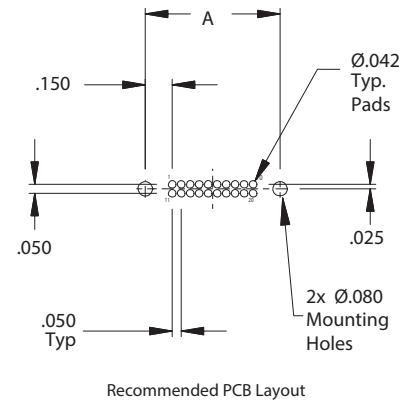

Contacts and Dimensions	
Contacts	A
4	0.350 (8.9)
8	0.450 (11.4)
10	0.500 (12.7)
12	0.550 (14.0)
16	0.650 (16.5)
20	0.750 (19.1)
24	0.850 (21.6)
28	0.950 (24.1)
30	1.000 (25.4)
32	1.050 (26.7)
36	1.150 (29.2)
40	1.250 (31.8)

AlphaLink® SL connector with spring loaded contacts and solder cups



171-134-01

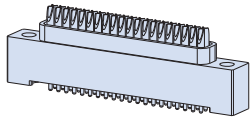

How To Order 171-134-01				
Sample Part Number	171-134-01	2	-10	T
Series / Basic Part No.	AlphaLink® SL connector with spring loaded contacts and solder cups			
Shell Finish	2 = Nickel 5 = Gold			
Contact Layout	See Table I and Contact Arrangements, page 4			
Hardware	T = Threaded thru hole Omit for thru hole			

B

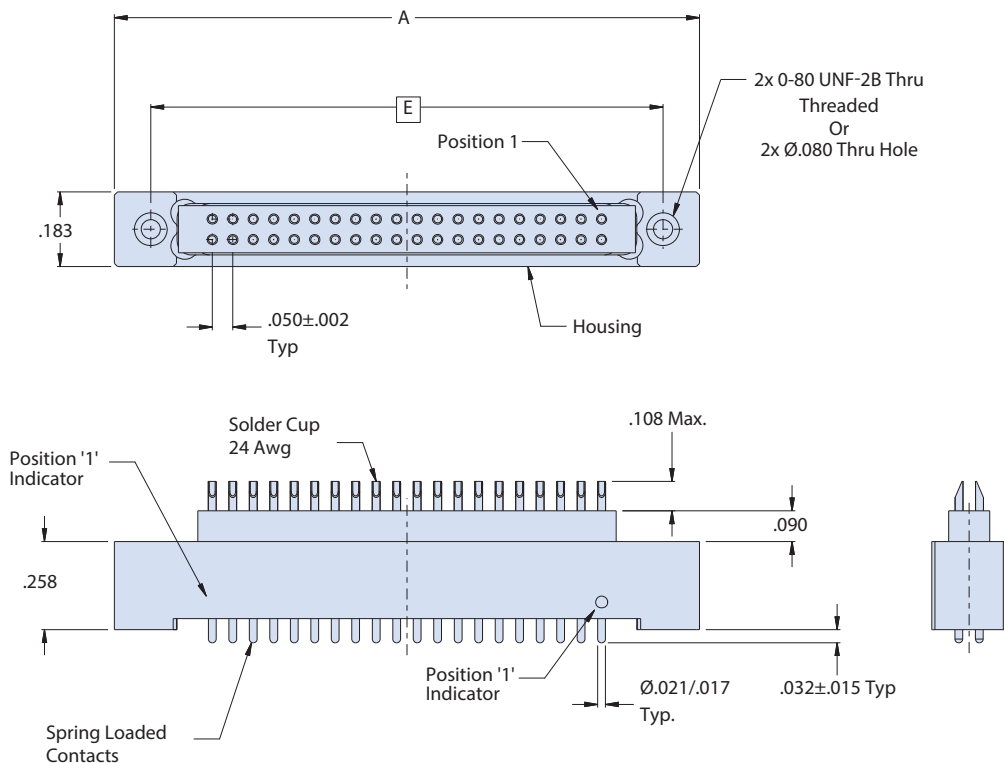

Table I: Layout and Dimensions

No. of contacts	A	E
4	0.527 (13.4)	0.350 (8.9)
8	0.627 (15.9)	0.450 (11.4)
10	0.677 (17.2)	0.500 (12.7)
12	0.727 (18.5)	0.550 (14.0)
16	0.827 (21.0)	0.650 (16.5)
20	0.927 (23.5)	0.750 (19.1)
24	1.027 (26.1)	0.850 (21.6)
28	1.127 (28.6)	0.950 (24.1)
30	1.177 (29.9)	1.000 (25.4)
32	1.227 (31.2)	1.050 (26.7)
36	1.327 (33.7)	1.150 (29.2)
40	1.427 (36.2)	1.250 (31.8)

Compatible Wire

AS22759 qualified single-ended data transmission wire for termination of AlphaLink® SL solder-cup connectors—see page 42 of this catalog

MATERIALS AND FINISHES

Shell: Aluminum Alloy
 Insulator: High temp thermoplastic
 Contacts: Copper Alloy/Gold Plated

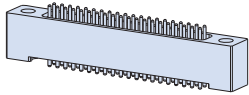

B

How To Order 171-134-02				
Sample Part Number	171-134-02	2	-10	T
Series / Basic Part No.	AlphaLink® SL connector with spring loaded contacts and PC tails			
Shell Finish	2 = Nickel 5 = Gold			
Contact Layout	See Table I and Contact Arrangements, page 4			
Hardware	T = Threaded thru hole Omit for thru hole			

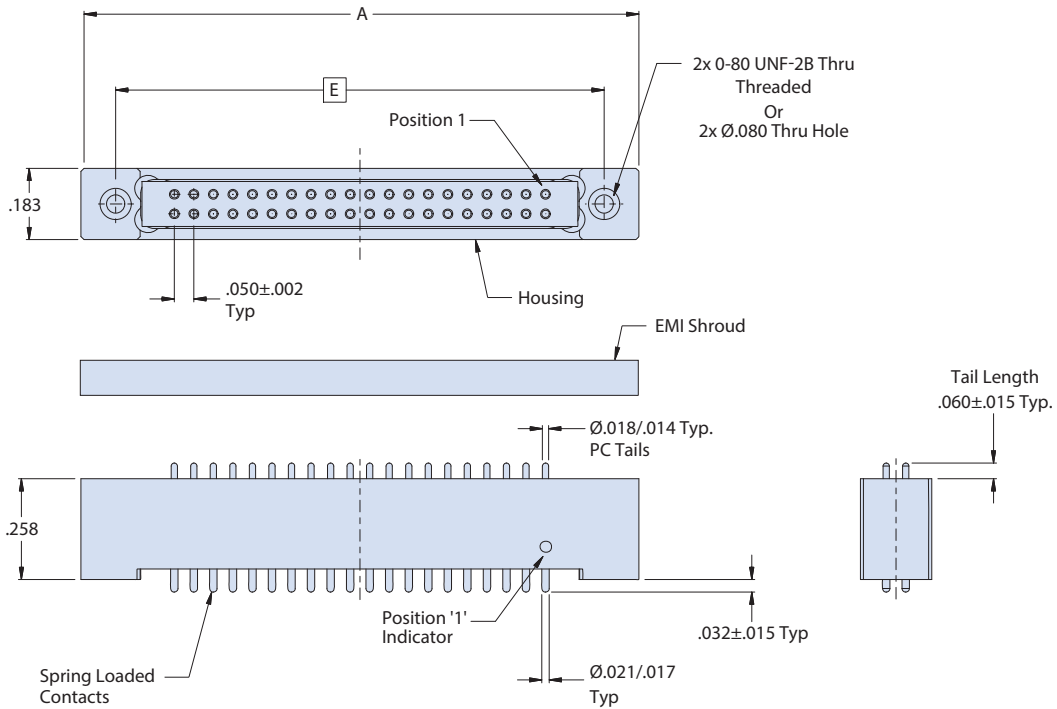

No. of contacts	A	E
4	0.527 (13.4)	0.350 (8.9)
8	0.627 (15.9)	0.450 (11.4)
10	0.677 (17.2)	0.500 (12.7)
12	0.727 (18.5)	0.550 (14.0)
16	0.827 (21.0)	0.650 (16.5)
20	0.927 (23.5)	0.750 (19.1)
24	1.027 (26.1)	0.850 (21.6)
28	1.127 (28.6)	0.950 (24.1)
30	1.177 (29.9)	1.000 (25.4)
32	1.227 (31.2)	1.050 (26.7)
36	1.327 (33.7)	1.150 (29.2)
40	1.427 (36.2)	1.250 (31.8)

MATERIALS AND FINISHES

Shell: Aluminum alloy
 Insulator: High temp thermoplastic
 Contacts: Copper Alloy/Gold Plated

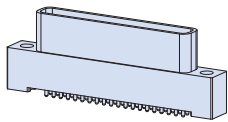

How To Order 171-134-03							
Sample Part Number	171-134-03	2	-10	-4	K	7	-18 T
Series / Basic Part No.	AlphaLink® SL connector with spring loaded contacts and pigtail wires						
Shell Finish	2 = Nickel 5 = Gold						
Contact Layout	See Table I and Contact Arrangements, page 4						
Wire Gage (AWG)	4 = #24 6 = #26 8 = #28 0 = #30						
Wire Type	K = M22759/11 (#24-#28) J = M22759/33 (#24-#30)						
Wire Color Code	1 = White 7 = Ten Color Repeat						
Wire Length	In inches						
Hardware	T = Threaded thru hole Omit for thru hole						

B

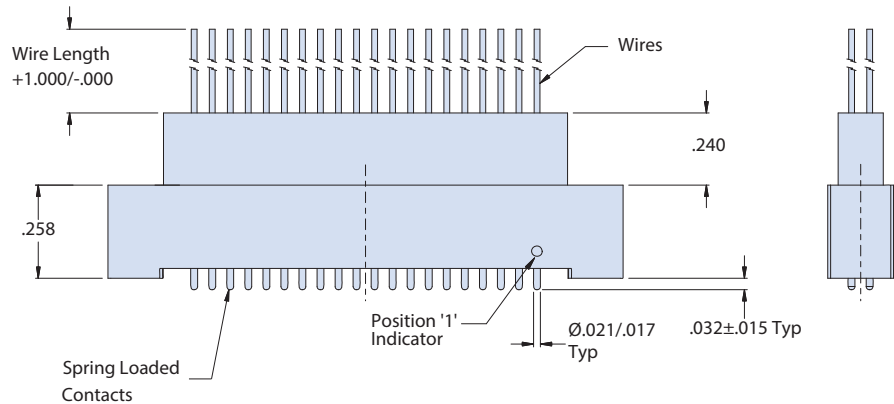
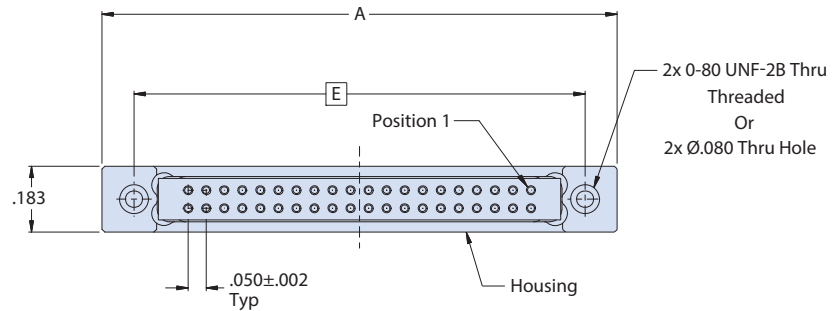

No. of contacts	A	E
4	0.527 (13.4)	0.350 (8.9)
8	0.627 (15.9)	0.450 (11.4)
10	0.677 (17.2)	0.500 (12.7)
12	0.727 (18.5)	0.550 (14.0)
16	0.827 (21.0)	0.650 (16.5)
20	0.927 (23.5)	0.750 (19.1)
24	1.027 (26.1)	0.850 (21.6)
28	1.127 (28.6)	0.950 (24.1)
30	1.177 (29.9)	1.000 (25.4)
32	1.227 (31.2)	1.050 (26.7)
36	1.327 (33.7)	1.150 (29.2)
40	1.427 (36.2)	1.250 (31.8)

MATERIALS AND FINISHES

Shell: Aluminum alloy
 Insulator: High temp thermoplastic
 Contacts: Copper Alloy/Gold Plated



SERIES 171

AlphaLink SL Flex Jumpers

The easiest and fastest way to incorporate flexible circuit cabling in your high-performance application

Glenair AlphaLink SL I/O-to-board jumper assemblies are cataloged according to I/O connector type. Glenair currently offers six families of AlphaLink jumpers for Series 801 and 804 Mighty Mouse, Series 79 Micro-Crimp, MIL-DTL-83513 Micro-D, Series 89 Nanominiature circular and rectangular, and our nanominiature Series 88 SuperFly. Flex-to-board solutions available in each family are designed to optimize weight and package size reduction as well as maintain electrical performance equivalent with I/O connector performance*.

* Contacts mapped 1-to-1 from I/O to B/L connector (unused B/L contacts not connected). For alternative wire schedules, please consult factory.



Easy-to-Order,
Ready-to-Use

- Solderless connection allows fast yet rugged PC board mating
- Easy ordering of high-performance I/O connector-to-board flex jumpers
- Chemically etched, copper-clad polyimide flex circuits offer excellent temperature tolerance, dimensional stability, and reduced size and weight
- Designed for optimal electrical performance, including matched-impedance applications
- Ideal for rapid prototyping
- Superior electrical and mechanical performance compared to other cabling options
- A high-availability, fast-turn catalog solution

AlphaLink SL flex jumpers selection guide

Circular connector family selection guide

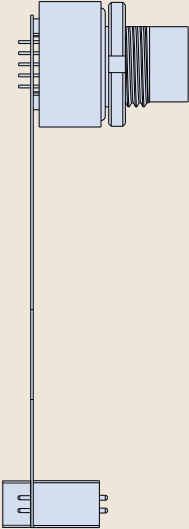
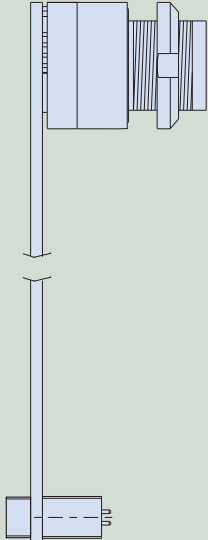
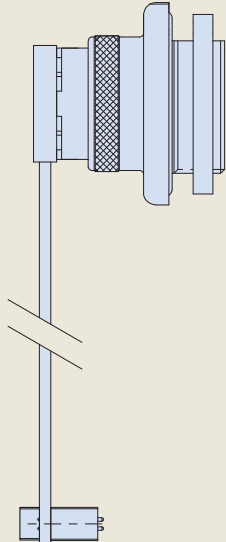
Nano Circular Section C	Series 88 SuperFly Section D	Series 80 Mighty Mouse Section E
		
<p>Glenair Series 89 Circular Nanominiature connectors with breakaway or threaded coupling in 6 contact arrangements, terminated with rugged polyimide-based flex to high-performance AlphaLink SL board level connectors.</p>	<p>Glenair Series 88 SuperFly connectors with quick-disconnect or threaded coupling in 7 contact arrangements, terminated with rugged polyimide-based flex to high-performance AlphaLink SL board level connectors.</p>	<p>Glenair Series 801 double-start ACME thread and Series 804 quick-disconnect Mighty Mouse receptacles in 8 contact arrangements terminated with rugged polyimide-based flex to high-performance AlphaLink SL board level connectors.</p>

Rectangular connector family selection guide

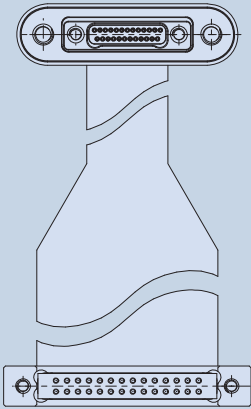
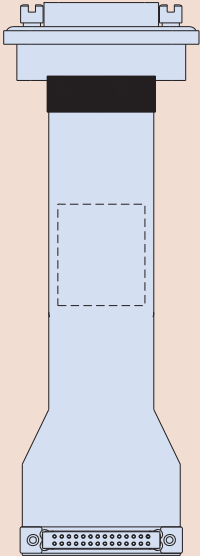
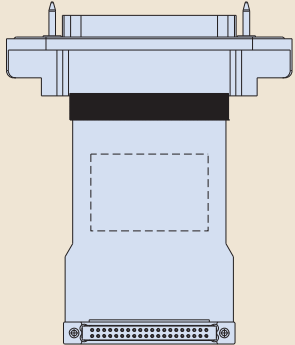
Rectangular Nano Section F	MIL-DTL-83513 Type Micro-D Section G	Series 79 Micro-Crimp Section H
		
<p>Glenair Series 89 Rectangular Nanominiature rear-panel-mount plugs or receptacles in 7 contact arrangements, terminated with rugged polyimide-based flex to high-performance AlphaLink SL board level connectors.</p>	<p>High-reliability Micro-D MIL-DTL-83513 type rectangular connectors in 7 contact arrangements, terminated with rugged polyimide-based flex to high-performance AlphaLink SL board level connectors.</p>	<p>Glenair Series 79 Micro-Crimp advanced-performance rectangular connectors in 7 contact arrangements, terminated with rugged polyimide-based flex to AlphaLink board level connectors.</p>



Circular Nano to AlphaLink flex jumper

Circular Nano to AlphaLink Flex Jumpers

Glenair Series 89 Circular Nanominiature connectors available in 6 contact arrangements, terminated with rugged polyimide-based flex to AlphaLink board level connectors.

Recommended Circular Nano I/O to AlphaLink Contact Arrangements* Receptacle Mating Face Views

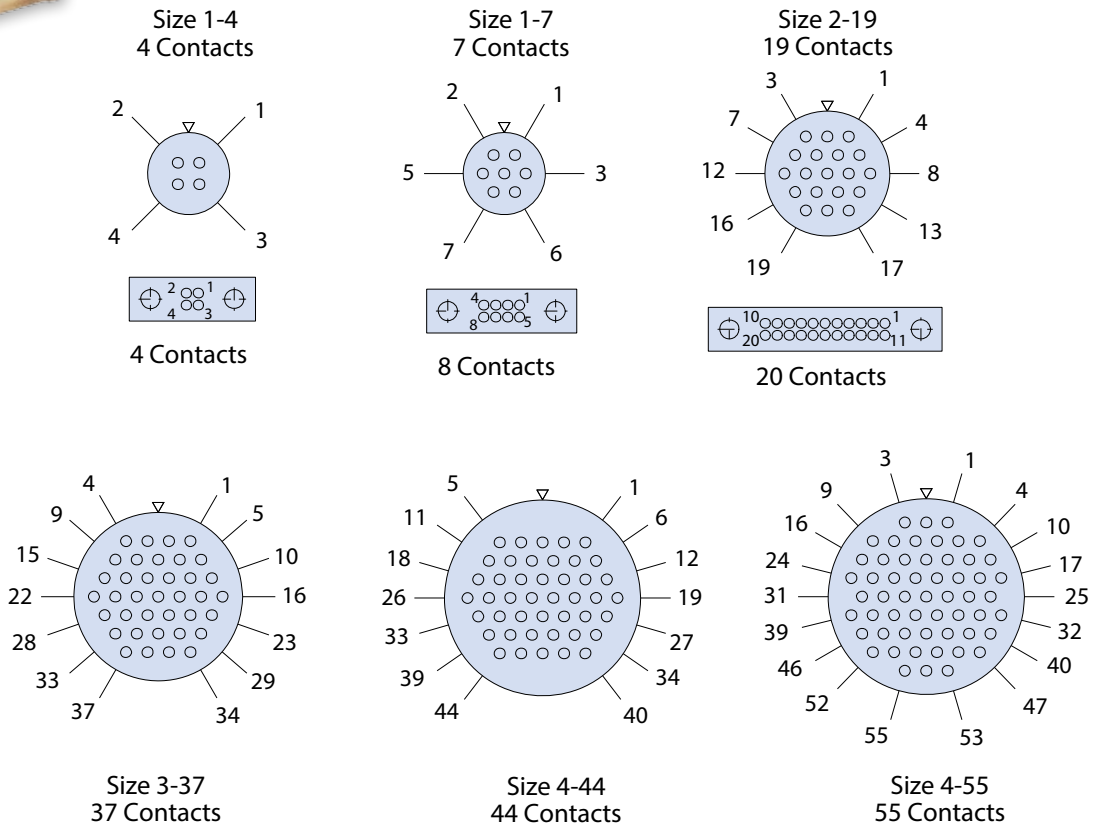

* These are recommended contact arrangements only, but do offer best availability. Contacts are mapped 1-to-1 from I/O to B/L connector (unused B/L contacts not connected). For alternative wire schedules, please consult factory.

To optimize the 40-contact AlphaLink board level connector, 40 contacts of a 44- or 55-contact size Circular Nanominiature connector can be used.

Contact arrangements • materials and finishes • dimensions • PCB layout • panel cutout

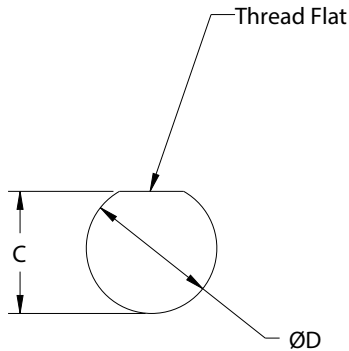

Panel Cut-Out

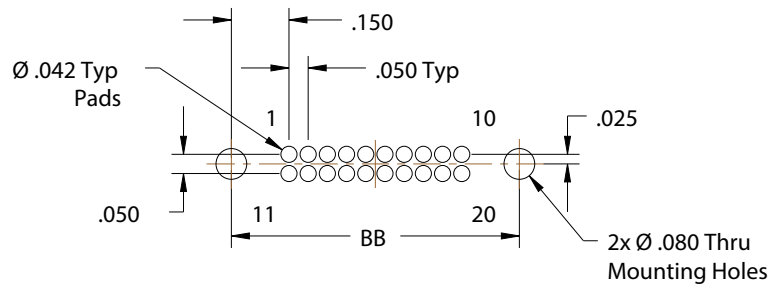

Recommended PCB Layout

Key Positions			
Size	Polarization	A°	B°
1-4	N	150	210
	A	75	210
1-7	N	95	230
	A	140	275
2-19	N	150	210
	A	75	210
3-37	N	150	210
	A	75	210
4-44	N	150	210
	A	75	210
4-55	N	95	230
	A	140	275

Table I: I/O Panel Mount Dimensions		
Arrangement	C +.002/- .001	ØD +.002/- .001
4	0.260 (6.6)	0.280 (7.1)
7	0.260 (6.6)	0.280 (7.1)
19	0.318 (8.1)	0.340 (8.6)
37	0.361 (9.2)	0.378 (9.6)
44	0.401 (10.2)	0.420 (10.7)
55	0.401 (10.2)	0.420 (10.7)

Table II: B/L AlphaLink Layout and Dimensions		
No. of contacts	AA	BB
4	0.527 (13.4)	0.350 (8.9)
8	0.627 (15.9)	0.450 (11.4)
10	0.677 (17.2)	0.500 (12.7)
12	0.727 (18.5)	0.550 (14.0)
16	0.827 (21.0)	0.650 (16.5)
20	0.927 (23.5)	0.750 (19.1)
24	1.027 (26.1)	0.850 (21.6)
28	1.127 (28.6)	0.950 (24.1)
30	1.177 (29.9)	1.000 (25.4)
32	1.227 (31.2)	1.050 (26.7)
36	1.327 (33.7)	1.150 (29.2)
40	1.427 (36.2)	1.250 (31.8)

I/O Shell Material/Finish		
Sym	Material	Finish
A2	Aluminum Alloy	Electroless Nickel
A5		Gold over Nickel
S1	Stainless Steel	Black Zinc Cobalt
S2		Passivate

Circular Nanominiature breakaway rear-panel-mount receptacle connector to AlphaLink SL flex jumper



893-012

SERIES 89 CIRCULAR NANOMINIATURE INPUT/OUTPUT (I/O) BREAKAWAY RECEPTACLE TO ALPHALINK SL SPRING LOADED CONTACT BOARD LEVEL (B/L) CONNECTOR

How To Order 893-012	
Sample Part Number	893-012 -19 N A2 -20 2 T -12 S
Series / Basic Part No.	Series 89 Circular Nanominiature Breakaway I/O receptacle to Series 171 AlphaLink SL
I/O Contact Arrangement	See Table I
I/O Polarization	N = Normal A = Alternate
I/O Shell and Spanner Nut Material and Finish	A2 = Aluminum / Electroless Nickel A5 = Aluminum / Gold over Nickel S1 = Stainless Steel / Zinc Cobalt (Black) S2 = Stainless Steel / Passivated
AlphaLink Layout	See Table II
AlphaLink Finish	2 = Nickel 5 = Gold
AlphaLink Hardware Option	Omit for .080+/- clearance hole in body, #0-80 UNF-2B threaded thru hole T = #0-80 UNF-2B Threaded Thru in Body, Contersink Clearance Hole in Cover
Assembly Length (L)	3 = 3.00 ± .05 inches 6 = 6.00 ± .05 inches 12 = 12.00 ± .05 inches
Optional Shielding	S = With shielding Omit for none

MATERIALS AND FINISHES

B/L connector shell: Aluminum alloy.
 I/O shell, jam nut: See P/N development
 I/O Insulator: LCP
 I/O O-ring: Fluorosilicone
 I/O Contacts: Gold Alloy per ASTM B477 and ASTM B541
 B/L Insulator: High Temp Thermoplastic
 B/L Contact: Copper Alloy/Gold Plated

NOTES

Input/Output Series 89 Nanominiature breakaway receptacle performance IAW MIL-DTL-32139
 As a minimum, assembly identified with date code, and Pin 1 identifier. Bag and tag with Glenair part number, CAGE code, and date code.
 Contacts mapped 1-to-1 from I/O to B/L connector (unused B/L contacts not connected). For alternative wire schedules, please consult factory.

Unused Cavities in I/O panel mount connector to be populated with contacts.

B/L AlphaLink SL interface dimensions IAW Glenair drawing 171-134-02. Interface shown for reference.

Unused cavities in B/L connector to be populated with contacts.

Flex Performance:

Shielding - EMI shielding film will be used when shielding option is chosen

Bend radius is 6 to 10 times the flex thickness.

Typical flex will be .01 ± .005 thick, rugged, potted, polyimide-based flex.

Flex cables are terminated from the I/O connector to the B/L connector on a 1 to 1 connection (unused B/L contacts are not connected)

Workmanship shall be IAW IPC-6013, Class 2.

Consult factory for more options and/or special designs and requirements

Circular Nanominiature breakaway rear-panel-mount receptacle connector to AlphaLink SL flex jumper

893-012

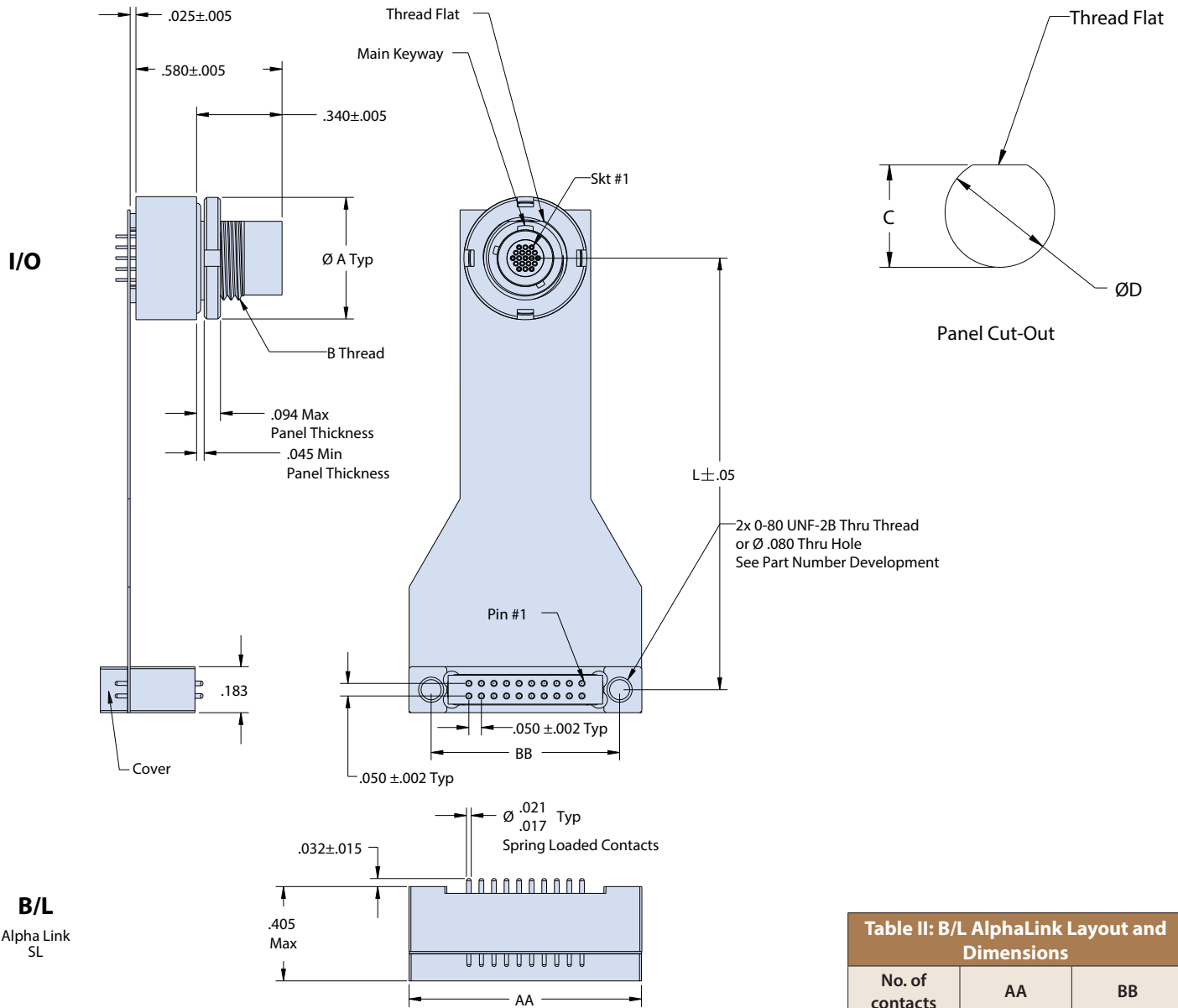

Arrangement	ØA	B Thread	C +.002/- .001	ØD +.002/- .001
4	0.429 (10.9)	M7.0 X 0.75-6G	0.260 (6.6)	0.280 (7.1)
7	0.429 (10.9)	M7.0 X 0.75-6G	0.260 (6.6)	0.280 (7.1)
19	0.488 (12.4)	M8.5 X 0.75-6G	0.318 (8.1)	0.340 (8.6)
37	0.528 (13.4)	M9.5 X 0.75-6G	0.361 (9.2)	0.378 (9.6)
44	0.567 (14.4)	M10.5 X 0.75-6G	0.401 (10.2)	0.420 (10.7)
55	0.567 (14.4)	M10.5 X 0.75-6G	0.401 (10.2)	0.420 (10.7)

No. of contacts	AA	BB
4	0.527 (13.4)	0.350 (8.9)
8	0.627 (15.9)	0.450 (11.4)
10	0.677 (17.2)	0.500 (12.7)
12	0.727 (18.5)	0.550 (14.0)
16	0.827 (21.0)	0.650 (16.5)
20	0.927 (23.5)	0.750 (19.1)
24	1.027 (26.1)	0.850 (21.6)
28	1.127 (28.6)	0.950 (24.1)
30	1.177 (29.9)	1.000 (25.4)
32	1.227 (31.2)	1.050 (26.7)
36	1.327 (33.7)	1.150 (29.2)
40	1.427 (36.2)	1.250 (31.8)

Circular Nanominiature threaded coupling rear-panel-mount receptacle connector to AlphaLink SL flex jumper

893-013

SERIES 89 CIRCULAR NANOMINIATURE INPUT/OUTPUT (I/O) THREADED-COUPLING RECEPTACLE TO ALPHALINK SL SPRING LOADED CONTACT BOARD LEVEL (B/L) CONNECTOR

How To Order 893-013	
Sample Part Number	893-013 -19 N A2 -20 2 T -12 S
Series / Basic Part No.	Series 89 Circular Nanominiature Threaded Coupling I/O receptacle to Series 171 AlphaLink SL
I/O Contact Arrangement	See Table I
I/O Polarization	N = Normal A = Alternate
I/O Shell and Spanner Nut Material and Finish	A2 = Aluminum / Electroless Nickel A5 = Aluminum / Gold over Nickel S1 = Stainless Steel / Zinc Cobalt (Black) S2 = Stainless Steel / Passivated
AlphaLink Layout	See Table II
AlphaLink Finish	2 = Nickel 5 = Gold
AlphaLink Hardware Option	Omit for .080+/- clearance hole in body, #0-80 UNF-2B threaded thru hole T = #0-80 UNF-2B Threaded Thru in Body, Contersink Clearance Hole in Cover
Assembly Length (L)	3 = 3.00 ± .05 inches 6 = 6.00 ± .05 inches 12 = 12.00 ± .05 inches
Optional Shielding	S = With shielding Omit for none

MATERIALS AND FINISHES

B/L connector shell: Aluminum alloy.
 I/O shell, jam nut: See P/N development
 I/O Insulator: LCP
 I/O O-ring: Fluorosilicone
 I/O Contacts: Gold Alloy per ASTM B477 and ASTM B541
 B/L Insulator: High Temp Thermoplastic
 B/L Contact: Copper Alloy/Gold Plated

NOTES

Input/Output Series 89 Nanominiature breakaway receptacle performance IAW MIL-DTL-32139
 As a minimum, assembly identified with date code, and Pin 1 identifier. Bag and tag with Glenair part number, CAGE code, and date code.
 Contacts mapped 1-to-1 from I/O to B/L connector (unused B/L contacts not connected). For alternative wire schedules, please consult factory.

Unused Cavities in I/O panel mount connector to be populated with contacts.

B/L AlphaLink SL interface dimensions IAW Glenair drawing 171-134-02. Interface shown for reference.

Unused cavities in B/L connector to be populated with contacts.

Flex Performance:

Shielding - EMI shielding film will be used when shielding option is chosen

Bend radius is 6 to 10 times the flex thickness.

Typical flex will be .01 ± .005 thick, rugged, potted, polyimide-based flex.

Flex cables are terminated from the I/O connector to the B/L connector on a 1 to 1 connection (unused B/L contacts are not connected)

Workmanship shall be IAW IPC-6013, Class 2.

Consult factory for more options and/or special designs and requirements

Circular Nanominiature threaded coupling rear-panel-mount receptacle connector to AlphaLink SL flex jumper

893-013

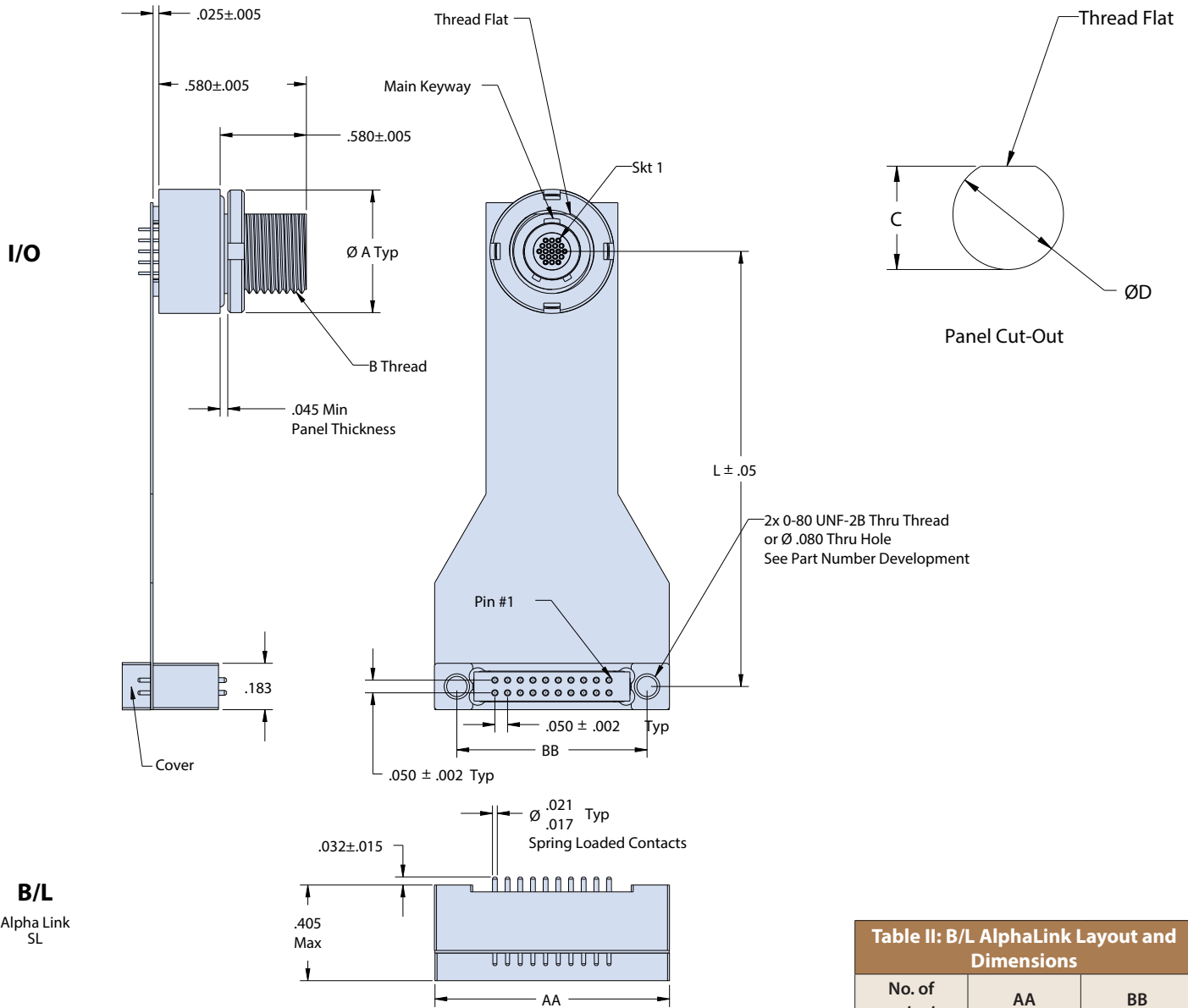

Arrangement	ØA	B Thread	C +.002/- .001	ØD +.002/- .001
4	0.429 (10.9)	M7.0 X 0.75-6G	0.260 (6.6)	0.280 (7.1)
7	0.429 (10.9)	M7.0 X 0.75-6G	0.260 (6.6)	0.280 (7.1)
19	0.488 (12.4)	M8.5 X 0.75-6G	0.318 (8.1)	0.340 (8.6)
37	0.528 (13.4)	M9.5 X 0.75-6G	0.361 (9.2)	0.378 (9.6)
44	0.567 (14.4)	M10.5 X 0.75-6G	0.401 (10.2)	0.420 (10.7)
55	0.567 (14.4)	M10.5 X 0.75-6G	0.401 (10.2)	0.420 (10.7)

No. of contacts	AA	BB
4	0.527 (13.4)	0.350 (8.9)
8	0.627 (15.9)	0.450 (11.4)
10	0.677 (17.2)	0.500 (12.7)
12	0.727 (18.5)	0.550 (14.0)
16	0.827 (21.0)	0.650 (16.5)
20	0.927 (23.5)	0.750 (19.1)
24	1.027 (26.1)	0.850 (21.6)
28	1.127 (28.6)	0.950 (24.1)
30	1.177 (29.9)	1.000 (25.4)
32	1.227 (31.2)	1.050 (26.7)
36	1.327 (33.7)	1.150 (29.2)
40	1.427 (36.2)	1.250 (31.8)



SuperFly to AlphaLink flex jumper

Superfly to AlphaLink Flex Jumpers

Glenair Series 88 SuperFly™ Cordsets represent a perfect storm of high-performance contacts, shells, wires, termination and mating technologies. SuperFly™ combines the weight-saving and performance advantages of nanominiature contacts in a precision package made to order for battlefield and other high-performance applications. Now available in turnkey flex jumper format for easy integration in printed circuit board applications, each SuperFly jumper ships with rugged Polyimide-based flex terminated to your choice of threaded or quick disconnect coupling SuperFly and an AlphaLink SL board level connector.



D

Recommended SuperFly I/O to AlphaLink Contact Arrangements*

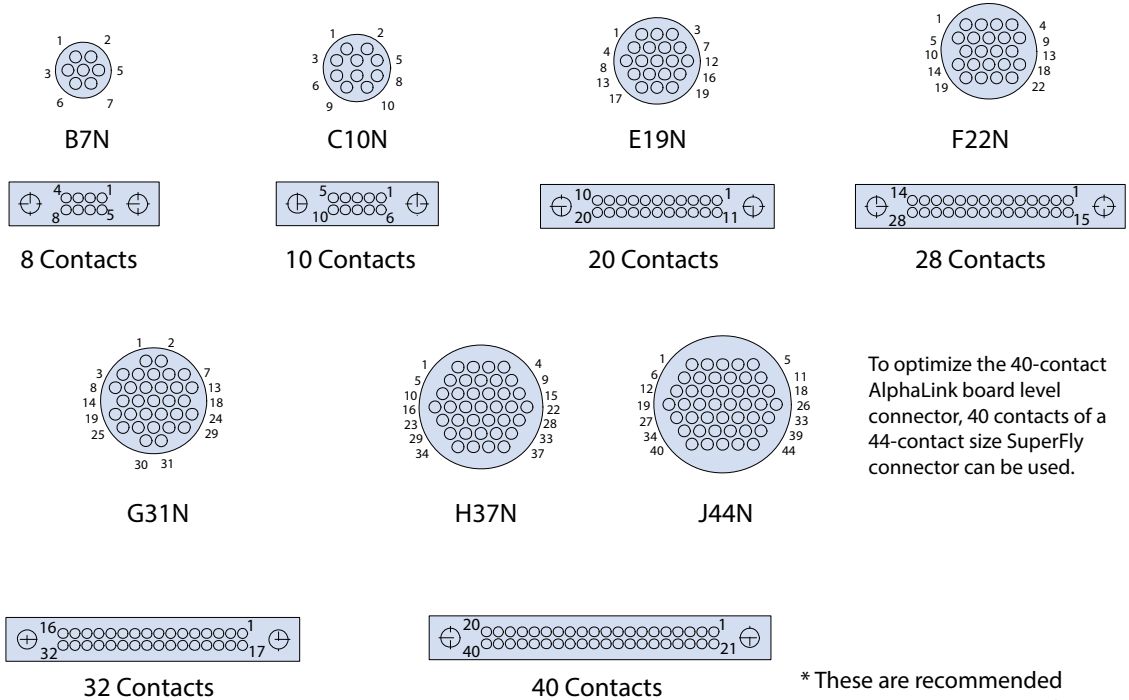

To optimize the 40-contact AlphaLink board level connector, 40 contacts of a 44-contact size SuperFly connector can be used.

* These are recommended contact arrangements only, but do offer best availability. Contacts are mapped 1-to-1 from I/O to B/L connector (unused B/L contacts not connected). For alternative wire schedules, please consult factory.

Contact arrangements • materials and finishes • dimensions • PCB layout • panel cutout

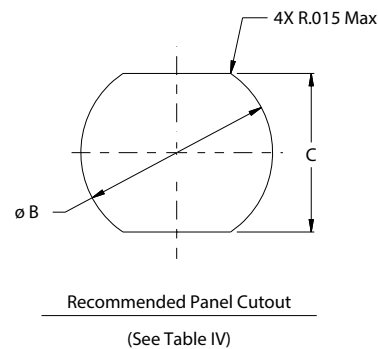
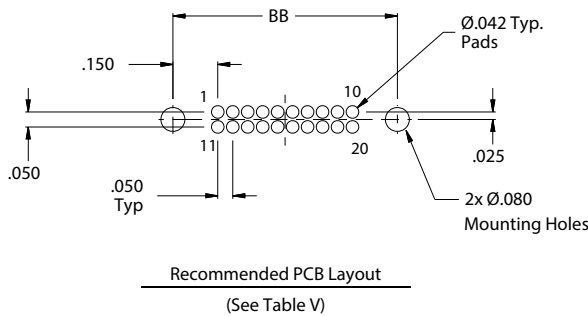

D

Table I - I/O Material/Finish		
Sym	Material	Finish
M	Aluminum Alloy	Electroless Nickel
ZR		Black Zinc-Nickel over Electroless Nickel
MT		Nickel-PTFE
NF		Olive drab over Cadmium
ZC	Stainless Steel	Black Zinc Cobalt
ZK		Passivate
ZMT		Nickel Teflon

Table III - Available I/O Insert Arrangement and B/L Assembly Pairs*			
Ins. Arr.	I/O Contact		B/L Layout
	Size	Qty	
B7N	Nano	7	8
C10N	Nano	10	10
E19N	Nano	19	20
F22N	Nano	22	28
G31N	Nano	31	32
H37N	Nano	37	40
J44N	Nano	44	40

* Contacts mapped 1-to-1 from I/O to B/L connector (unused B/L contacts not connected). For alternative wire schedules, please consult factory.

Table IV - I/O Connector Panel Cutout Dimensions			
Shell Size	Ø A	Ø B	C Flats
B	.392 (10.0)	.283 (7.2)	.241 (6.1)
C	.412 (10.5)	.305 (7.7)	.261 (6.6)
E	.451 (11.5)	.344 (8.7)	.300 (7.6)
F	.471 (12.0)	.364 (9.2)	.320 (8.1)
G	.490 (12.4)	.383 (9.7)	.340 (8.6)
H	.530 (13.5)	.349 (8.9)	.379 (9.6)
J	.569 (14.5)	.459 (11.7)	.418 (10.6)

Table V - B/L Connector Dimensions		
Layout	AA	BB
4	.527 (13.4)	.350 (8.9)
8	.627 (15.9)	.450 (11.4)
10	.677 (17.2)	.500 (12.7)
16	.827 (21.0)	.650 (16.5)
20	.927 (23.5)	.750 (19.1)
28	1.127 (28.6)	.950 (24.1)
32	1.227 (31.2)	1.050 (26.7)
40	1.427 (36.2)	1.250 (31.8)

SuperFly quick-disconnect rear-panel-mount receptacle connector to AlphaLink SL flex jumper

880-034

SERIES 88 SUPERFLY INPUT/OUTPUT (I/O) QDC RECEPTACLE TO ALPHALINK SL SPRING LOADED CONTACT BOARD LEVEL (B/L) CONNECTOR

How To Order 880-034								
Sample Part Number	880-034R	A	-F22N	-M	-2	T	-6	S
Series / Basic Part No.	Series 88 SuperFly QDC I/O receptacle to Series 171 AlphaLink SL							
I/O Insert Configuration	A = Unshrouded contacts (e.g. Nano socket) B = Shrouded contacts (e.g. Nano TwistPin)							
I/O Shell Size / Contact Arrangement	B7N, C10N, E19N, F22N, G31N, H37N, J44N (See Contact Arrangements and Table III, page 16 – 17)							
I/O Shell Material/Finish	(See Table I)							
AlphaLink Finish	2 = Nickel 5 = Gold							
AlphaLink Hardware Option	T = Threaded thru hole Omit for thru hole							
Assembly Length (L)	3 = 3.00 ± .05 inches 6 = 6.00 ± .05 inches 12 = 12.00 ± .05 inches							
Optional Shielding	S = With shielding Omit for none							

D

Sym	Material	Finish
M	Aluminum Alloy	Electroless Nickel
ZR		Black Zinc-Nickel over Electroless Nickel
MT		Nickel-PTFE
NF		Olive drab over Cadmium
ZC	Stainless Steel	Black Zinc Cobalt
ZK		Passivate
ZMT		Nickel Teflon

MATERIALS AND FINISHES

B/L connector shell: Aluminum alloy. I/O shell, jam nut: See Table I
 Insulator: Liquid crystal polymer or equivalent
 Seals, grommet, O-ring: Fluorosilicone or equivalent
 Contacts: Copper Alloy/Gold Plated
 Potting: Epoxy

NOTES

Input/Output Series 88 SuperFly quick-disconnect receptacle:
 I/O connector will mate with all plug QDC SuperFly connectors with same polarization and opposite insert configuration.
 Insert arrangement per 889-001. See page 16 and 17, Table III for available arrangements. Unshrouded configurations are opposite of shrouded.
 Contacts mapped 1-to-1 from I/O to B/L connector (unused B/L contacts not connected). For alternative wire schedules, please consult factory.
 See 880-032 for other connector dimensions

Board Level AlphaLink SL connector:

B/L AlphaLink SL connectors are built in accordance with Glenair drawing 171-134-02

B/L connectors are paired with I/O connectors as shown on Table III

Flex Performance:

Shielding - EMI shielding film.

Bend radius is 6 to 10 times the flex thickness.

Typical flex will be .01 ± .005 thick, rugged, potted, polyimide-based flex.

Flex cables are terminated from the I/O connector to the B/L connector on a 1 to 1 connection (unused B/L contacts are not connected)

Workmanship shall be IAW IPC-6013, Class 2.

Consult factory for more options and/or special designs and requirements

SuperFly quick-disconnect rear-panel-mount receptacle connector to AlphaLink SL flex jumper

880-034

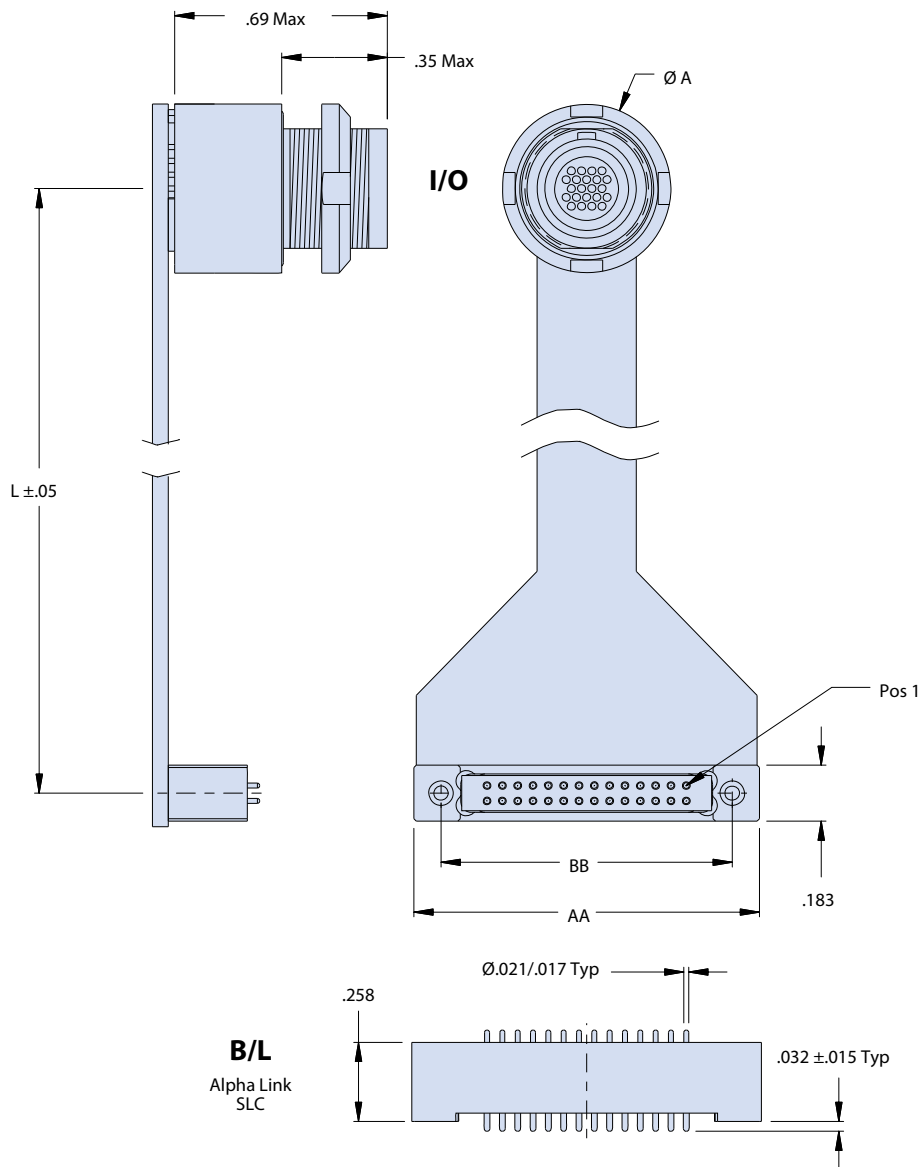

Table IV - I/O Connector Dimensions

Shell Size	Ø A	Ø B	C Flats
B	.392 (10.0)	.283 (7.2)	.241 (6.1)
C	.412 (10.5)	.305 (7.7)	.261 (6.6)
E	.451 (11.5)	.344 (8.7)	.300 (7.6)
F	.471 (12.0)	.364 (9.2)	.320 (8.1)
G	.490 (12.4)	.383 (9.7)	.340 (8.6)
H	.530 (13.5)	.349 (8.9)	.379 (9.6)
J	.569 (14.5)	.459 (11.7)	.418 (10.6)

Table V - B/L Connector Dimensions

Layout	AA	BB
4	.527 (13.4)	.350 (8.9)
8	.627 (15.9)	.450 (11.4)
10	.677 (17.2)	.500 (12.7)
16	.827 (21.0)	.650 (16.5)
20	.927 (23.5)	.750 (19.1)
28	1.127 (28.6)	.950 (24.1)
32	1.227 (31.2)	1.050 (26.7)
40	1.427 (36.2)	1.250 (31.8)



SuperFly threaded rear-panel-mount receptacle connector to AlphaLink SL flex jumper



881-021

SERIES 88 SUPERFLY INPUT/OUTPUT (I/O) THREADED RECEPTACLE TO ALPHALINK SL SPRING LOADED CONTACT BOARD LEVEL (B/L) CONNECTOR

How To Order 881-021	
Sample Part Number	881-021R A -F22N -M -2 T -6 S
Series / Basic Part No.	Series 88 SuperFly QDC I/O receptacle to Series 171 AlphaLink SL
I/O Insert Configuration	A = Unshrouded contacts (e.g. Nano socket) B = Shrouded contacts (e.g. Nano TwistPin)
I/O Shell Size / Contact Arrangement	B7N, C10N, E19N, F22N, G31N, H37N, J44N (See Contact Arrangements and Table III, page 16 – 17)
I/O Shell Material/Finish	(See Table I)
AlphaLink Finish	2 = Nickel 5 = Gold
AlphaLink Hardware Option	T = Threaded thru hole Omit for thru hole
Assembly Length (L)	3 = 3.00 ± .05 inches 6 = 6.00 ± .05 inches 12 = 12.00 ± .05 inches
Optional Shielding	S = With shielding Omit for none

D

Sym	Material	Finish
M	Aluminum Alloy	Electroless Nickel
ZR		Black Zinc-Nickel over Electroless Nickel
MT		Nickel-PTFE
NF		Olive drab over Cadmium
ZC	Stainless Steel	Black Zinc Cobalt
ZK		Passivate
ZMT		Nickel Teflon

MATERIALS AND FINISHES

B/L connector shell: Aluminum alloy. I/O shell, jam nut: See Table I
 Insulator: Liquid crystal polymer or equivalent
 Seals, grommet, O-ring: Fluorosilicone or equivalent
 Contacts: Copper Alloy/Gold Plated
 Potting: Epoxy

NOTES

Input/Output Series 88 SuperFly threaded receptacle:
 I/O connector will mate with all plug threaded SuperFly connectors with same polarization and opposite insert configuration.
 Insert arrangement per 889-001. See page 16 and 17, Table III for available arrangements. Unshrouded configurations are opposite of shrouded.
 Contacts mapped 1-to-1 from I/O to B/L connector (unused B/L contacts not connected). For alternative wire schedules, please consult factory.
 See 881-019 for other connector dimensions

Board Level AlphaLink SL connector:

B/L AlphaLink SL connectors are built in accordance with Glenair drawing 171-134-02

B/L connectors are paired with I/O connectors as shown on Table III

Flex Performance:

Shielding - EMI shielding film.

Bend radius is 6 to 10 times the flex thickness.

Typical flex will be .01 ± .005 thick, rugged, potted, polyimide-based flex.

Flex cables are terminated from the I/O connector to the B/L connector on a 1 to 1 connection (unused B/L contacts are not connected)

Workmanship shall be IAW IPC-6013, Class 2.

Consult factory for more options and/or special designs and requirements

SuperFly threaded rear-panel-mount receptacle connector to AlphaLink SL flex jumper

881-021

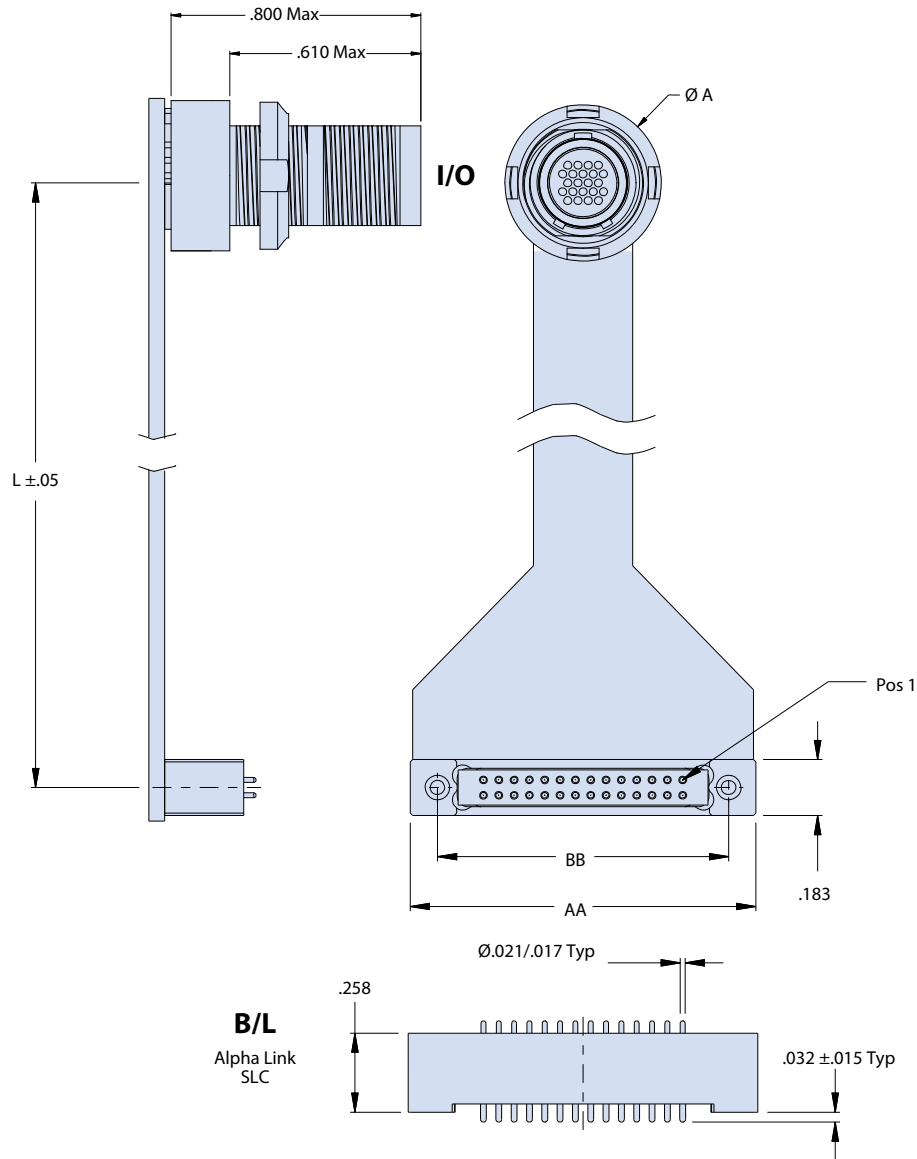

Table IV - I/O Connector Dimensions

Shell Size	Ø A	Ø B	C Flats
B	.392 (10.0)	.283 (7.2)	.241 (6.1)
C	.412 (10.5)	.305 (7.7)	.261 (6.6)
E	.451 (11.5)	.344 (8.7)	.300 (7.6)
F	.471 (12.0)	.364 (9.2)	.320 (8.1)
G	.490 (12.4)	.383 (9.7)	.340 (8.6)
H	.530 (13.5)	.349 (8.9)	.379 (9.6)
J	.569 (14.5)	.459 (11.7)	.418 (10.6)

Table V - B/L Connector Dimensions

Layout	AA	BB
4	.527 (13.4)	.350 (8.9)
8	.627 (15.9)	.450 (11.4)
10	.677 (17.2)	.500 (12.7)
16	.827 (21.0)	.650 (16.5)
20	.927 (23.5)	.750 (19.1)
28	1.127 (28.6)	.950 (24.1)
32	1.227 (31.2)	1.050 (26.7)
40	1.427 (36.2)	1.250 (31.8)



MIGHTY MOUSE TO ALPHALINK FLEX JUMPERS

Contact arrangements • dimensions • alternate key positions



Mighty Mouse to AlphaLink Flex Jumpers

Glenair Series 801 double-start ACME thread and Series 804 quick-disconnect Mighty Mouse receptacles in 8 contact arrangements terminated with rugged polyimide-based flex to high-performance AlphaLink SL board level connectors.



Mighty Mouse to AlphaLink flex jumper

Recommended Mighty Mouse I/O to AlphaLink Contact Arrangements*

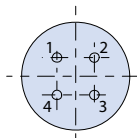

6-4

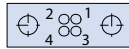

4 Contacts

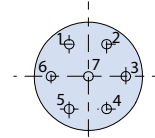

6-7

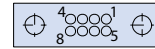

8 Contacts

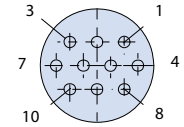

7-10



10 Contacts

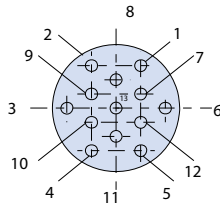

8-13

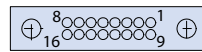

16 Contacts

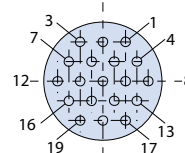

9-19

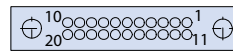

20 Contacts

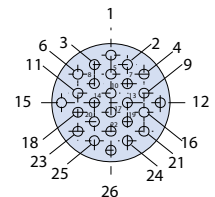

10-26

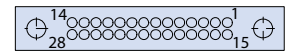

28 Contacts

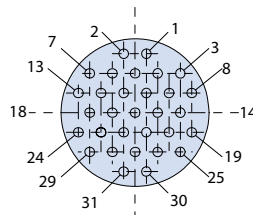

11-31

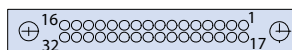

32 Contacts

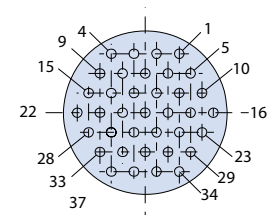

12-37
(13-37)



40 Contacts

*These are recommended contact arrangements only, but do offer best availability. Contacts are mapped 1-to-1 from I/O to B/L connector (unused B/L contacts not connected). For alternative wire schedules, please consult factory.

MIGHTY MOUSE TO ALPHALINK FLEX JUMPERS

Contact arrangements • dimensions • alternate key positions



Table IV Available I/O Insert Arrangement and B/L Assembly Pairs*			
Ins. Arr.	I/O Contact		B/L Layout
	Size	Qty	
6-4	23	4	4
6-7	23	7	8
7-10	23	10	10
8-13	23	13	16
9-19	23	19	20
10-26	23	26	28
11-31	23	31	32
12-37/13-37	23	37	40

* Contacts mapped 1-to-1 from I/O to B/L connector (unused B/L contacts not connected). For alternative wire schedules, please consult factory.

Table V - B/L Connector Dimensions		
Layout	AA	BB
4	.527 (13.4)	.350 (8.9)
8	.627 (15.9)	.450 (11.4)
10	.677 (17.2)	.500 (12.7)
16	.827 (21.0)	.650 (16.5)
20	.927 (23.5)	.750 (19.1)
28	1.127 (28.6)	.950 (24.1)
32	1.227 (31.2)	1.050 (26.7)
40	1.427 (36.2)	1.250 (31.8)

Table VII I/O Connector Alternate Key and Keyway Position		
Position	A°	B°
A	150°	210°
B	75°	210°
C	95°	230°
D	140°	275°
E	75°	275°
F	95°	210°

MATERIALS AND FINISHES

B/L connector shell: Aluminum alloy. I/O shell, jam nut: See Table I
 Insulator: Liquid crystal polymer
 Seals, grommet, O-ring: Fluorosilicone
 Contacts: Copper Alloy/Gold Plated
 Potting: Epoxy

NOTES

Input/Output Series 801 and 804 Mighty Mouse connectors:
 I/O connector will mate with all quick-coupling high density plug connectors with same polarization and opposite contact gender
 Contacts mapped 1-to-1 from I/O to B/L connector (unused B/L contacts not connected). For alternative wire schedules, please consult factory.

Board Level AlphaLink SL connector:

B/L AlphaLink SL connectors are built in accordance with Glenair drawing 171-134-02

B/L connectors are paired with I/O connectors as shown on Table IV

Flex Performance:

Shielding - EMI shielding film.

Bend radius is 6 to 10 times the flex thickness.

Typical flex will be .01 ± .005 thick, rugged, potted, polyimide-based flex.

Flex cables are terminated from the I/O connector to the B/L connector on a 1 to 1 connection (unused B/L contacts are not connected)

Workmanship shall be IAW IPC-6013, Class 2.

Consult factory for more options and/or special designs and requirements



Rear-panel-mount environmental double-start ACME thread connector to AlphaLink SL flex jumper

801-110

SERIES 801 MIGHTY MOUSE INPUT/OUTPUT (I/O) JAM NUT OR SQUARE FLANGE RECEPTACLE TO ALPHALINK SL SPRING LOADED CONTACT BOARD LEVEL (B/L) CONNECTOR

How To Order 801-110										
Sample Part Number	801-110	-07	NF	10-26	P	A	-2	T	-6	S
Series / Basic Part No.	Series 801 Mighty Mouse I/O receptacle to Series 171 AlphaLink SL									
I/O Connector Style	02 = Square flange receptacle 07 = Jam nut receptacle									
I/O Material / Finish	See Table I									
I/O Insert Arrangement	6-4, 6-7, 7-10, 8-13, 9-19, 10-26, 11-31, 13-37 (See Table IV)									
I/O Contact Gender	P = Pin S = Socket									
I/O Alternate Polarization	A, B, C, D, E, F (See Table VII)									
AlphaLink Finish	2 = Nickel 5 = Gold									
AlphaLink Hardware Option	T = Threaded thru hole Omit for thru hole									
Assembly Length	3 = 3.00 ± .05 inches 6 = 6.00 ± .05 inches 12 = 12.00 ± .05 inches									
Optional Shielding	S = With shielding Omit for none									

Shell Size	A Sq	B Bsc	Ø C	Ø D	E Flat	F Flat	J Holes
6	.590 (15.0)	.423 (10.7)	.750 (19.1)	.635 (16.1)	.595 (15.1)	.410 (10.4)	.096 (2.4) .091 (2.3)
7	.650 (16.5)	.483 (12.3)	.850 (21.6)	.755 (19.2)	.723 (18.4)	.536 (13.6)	
8	.712 (18.1)	.545 (13.8)	.938 (23.8)	.755 (19.2)	.723 (18.4)	.536 (13.6)	
9	.850 (21.6)	.607 (15.4)	1.125 (28.6)	.830 (21.1)	.790 (20.1)	.596 (15.1)	.130 (3.3) .126 (3.2)
10	.890 (22.6)	.670 (17.0)	1.188 (30.2)	.890 (22.6)	.855 (21.7)	.658 (16.7)	
11	.935 (23.7)	.715 (18.2)	1.250 (31.8)	.960 (24.4)	.925 (23.5)	.718 (18.2)	
13	1.030 (26.2)	.812 (20.6)	1.375 (34.9)	1.078 (27.4)	1.044 (26.5)	.845 (21.5)	

Shell Size	K Thread	L Thread	Ø M	N Flat	Ø P	Ø R
6	.3750-.05P-.1L-2A	.4375-28 UNEF-2A	.330 (8.4)	0.418 (10.6) 0.414 (10.5)	.448 (11.4)	.390 (9.9)
7	.4375-.05P-.1L-2A	.5625-32 UN-2A	.432 (11.0)	0.544 (13.8) 0.540 (13.7)	.573 (14.6)	.450 (11.4)
8	.5000-.05P-.1L-2A	.5625-32 UN-2A	.493 (12.5)	0.544 (13.8) 0.540 (13.7)	.573 (14.6)	.510 (13.0)
9	.5625-.05P-.1L-2A	.6250-28 UN-2A	.551 (14.0)	0.604 (15.3) 0.600 (15.2)	.635 (16.1)	.575 (14.6)
10	.6250-.05P-.1L-2A	.6875-28 UN-2A	.620 (15.7)	0.668 (17.0) 0.664 (16.9)	.698 (17.7)	.640 (16.3)
11	.6875-.05P-.1L-2A	.7500-28 UN-2A	.662 (16.8)	0.728 (18.5) 0.724 (18.4)	.760 (19.3)	.700 (17.8)
13	.8125-.1P-.2L-2A	.8750-28 UN-2A	.703 (17.9)	0.853 (21.7) 0.849 (21.6)	.885 (22.5)	.825 (21.0)

Rear-panel-mount environmental double-start ACME thread connector to AlphaLink SL flex jumper

801-110

07 - JAM NUT MOUNT I/O RECEPTACLE

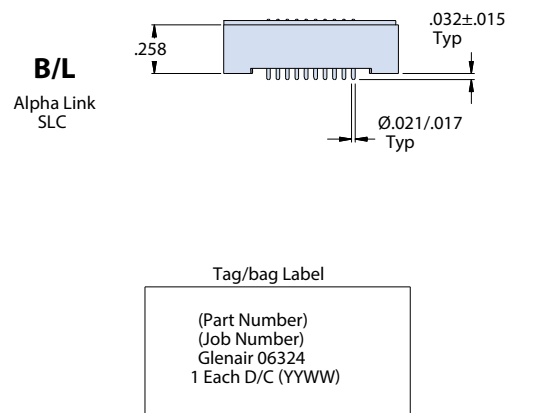
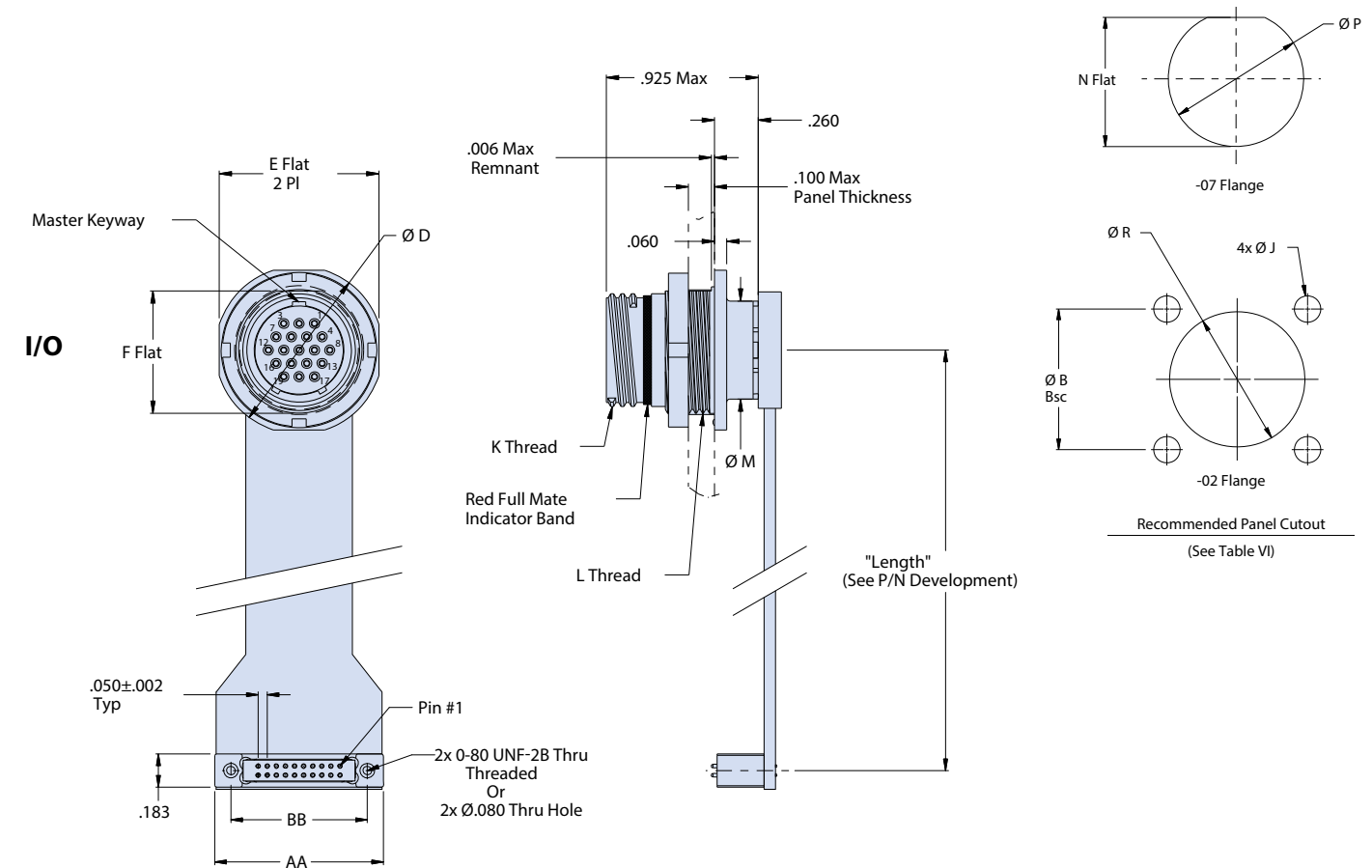

02 - SQUARE FLANGE I/O RECEPTACLE

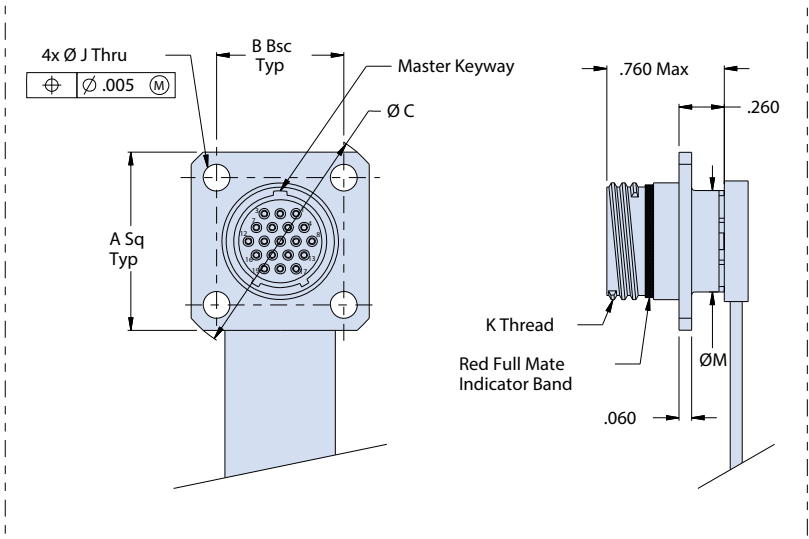

MIGHTY MOUSE TO ALPHALINK FLEX JUMPERS

Rear-panel-mount environmental push-pull connector to AlphaLink SL flex jumper



804-110

SERIES 804 MIGHTY MOUSE INPUT/OUTPUT (I/O) JAM-NUT RECEPTACLE TO ALPHALINK SL SPRING LOADED CONTACT BOARD LEVEL (B/L) CONNECTOR

How To Order 804- 110										
Sample Part Number	804-110	-07	NF	10-26	P	A	-2	T	-6	S
Series / Basic Part No.	Series 804 Mighty Mouse I/O receptacle to Series 171 AlphaLink SL									
I/O Connector Style	07 = Jam nut receptacle									
I/O Material / Finish	See Table I									
I/O Insert Arrangement	6-4, 6-7, 7-10, 8-13, 9-19, 10-26, 11-31, 13-37 (See Table IV)									
I/O Contact Gender	P = Pin S = Socket									
I/O Alternate Polarization	A, B, C, D, E, F (See Table VII)									
AlphaLink Finish	2 = Nickel 5 = Gold									
AlphaLink Hardware Option	T = Threaded thru hole Omit for thru hole									
Assembly Length	3 = 3.00 ± .05 inches 6 = 6.00 ± .05 inches 12 = 12.00 ± .05 inches									
Optional Shielding	S = With shielding Omit for none									

E

Table VI - Series 804 I/O Connector Dimensions and Cutouts								
Shell Size	A Thread	Ø B	Ø C	D-Flat	Ø E	Ø F	M Flat	Ø N
6	.5000-32 UN-2A	.730 (18.5)	.625 (15.9)	.467 (11.9)	.330 (8.4)	.483 (12.3)	.479 (12.2) .475 (12.1)	.510 (13.0)
7	.6250-28 UN-2A	.910 (23.1)	.750 (19.1)	.594 (15.1)	.432 (11.0)	.570 (14.5)	.606 (15.4) .601 (15.3)	.635 (16.1)
8	.6250-28 UN-2A	.955 (24.3)	.750 (19.1)	.594 (15.1)	.493 (12.5)	.593 (15.1)	.606 (15.4) .601 (15.3)	.635 (16.1)
9	.6875-28 UN-2A	1.000 (25.4)	.812 (20.6)	.655 (16.6)	.551 (14.0)	.685 (17.4)	.667 (16.9) .663 (16.8)	.695 (17.7)
10	.7500-28 UN-2A	1.085 (27.6)	.875 (22.2)	.721 (18.3)	.620 (15.7)	.725 (18.4)	.734 (18.6) .729 (18.5)	.760 (19.3)
11	.8125-28 UN-2A	1.135 (28.8)	.938 (23.8)	.788 (20.0)	.662 (16.8)	.810 (20.6)	.801 (20.3) .796 (20.2)	.822 (20.9)
12	.8750-28 UN-2A	1.190 (30.2)	1.000 (25.4)	.843 (21.4)	.703 (17.9)	.850 (21.6)	.855 (21.7) .851 (21.6)	.885 (22.5)

MIGHTY MOUSE TO ALPHALINK FLEX JUMPERS

Rear-panel-mount environmental push-pull connector to AlphaLink SL flex jumper



804-110

07 - JAM NUT MOUNT I/O RECEPTACLE

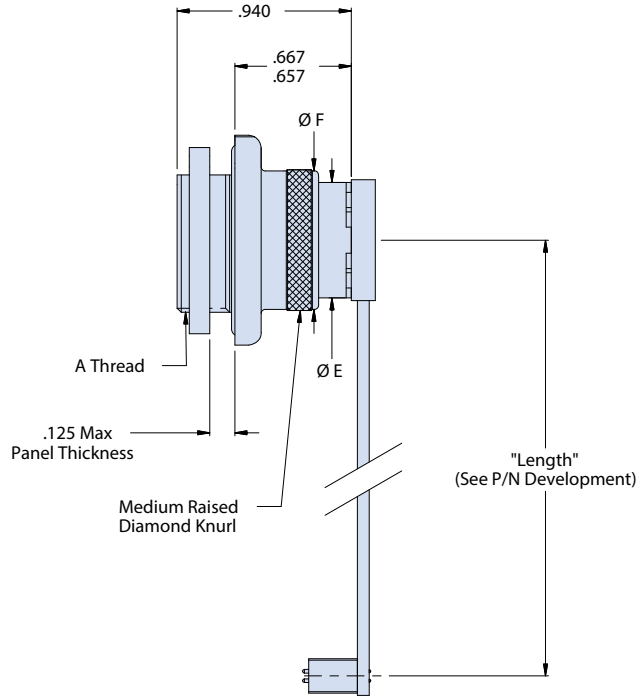
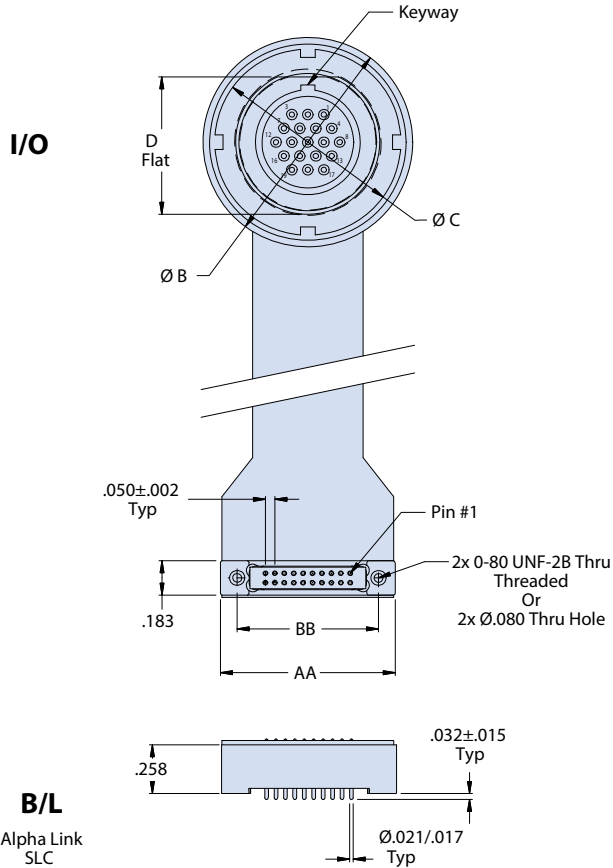

Tag/bag Label

(Part Number)
(Job Number)
Glenair 06324
1 Each D/C (YYWW)

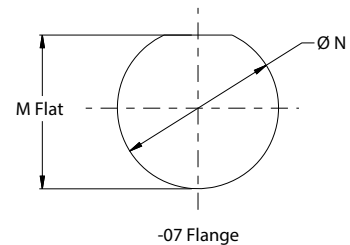

Recommended Panel Cutout

(See Table VI)





Rectangular Nano to AlphaLink flex jumper

Rectangular Nano to AlphaLink Flex Jumpers

Glenair Series 89 Rectangular Nanominiature connectors available in 6 contact arrangements, terminated with rugged polyimide-based flex to AlphaLink board level connectors.

Recommended Rectangular Nano I/O to AlphaLink Contact Arrangements*

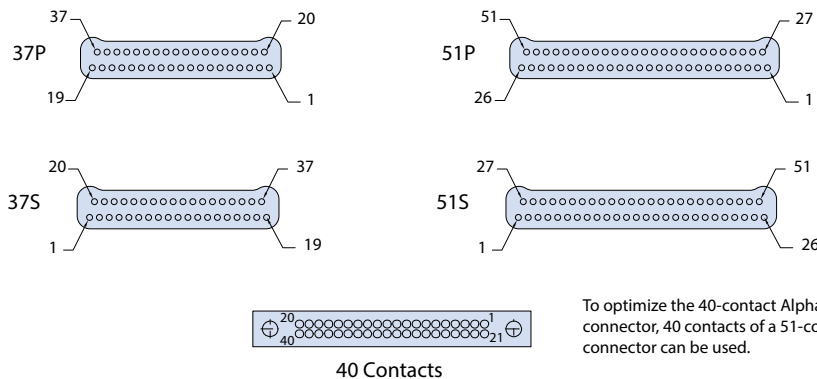
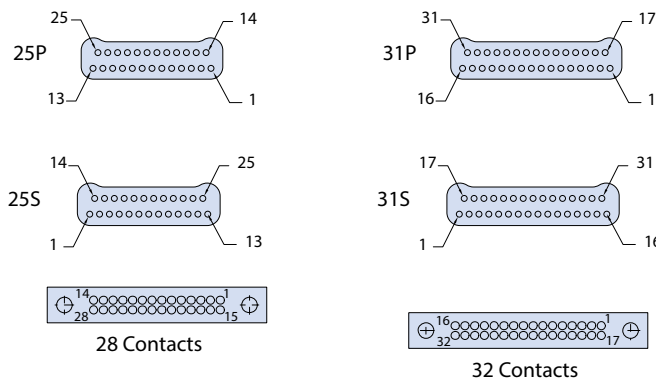
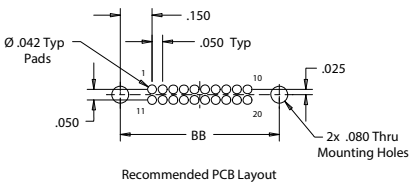
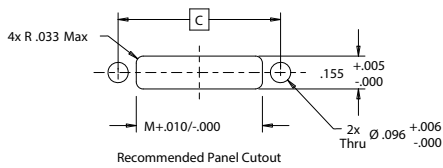
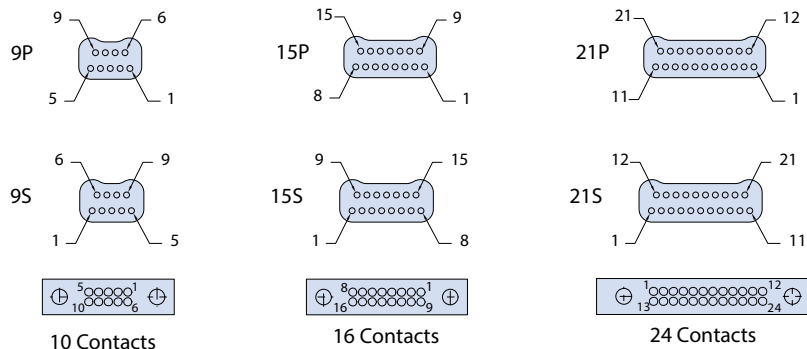

* These are recommended contact arrangements only, but do offer best availability. Contacts are mapped 1-to-1 from I/O to B/L connector (unused B/L contacts not connected). For alternative wire schedules, please consult factory.

To optimize the 40-contact AlphaLink board level connector, 40 contacts of a 51-contact size Nano connector can be used.

Rectangular Nanominiature rear-panel-mount connectors to AlphaLink SL flex jumper

891-041 • How to order

SERIES 89 RECTANGULAR NANOMINIATURE INPUT/OUTPUT (I/O) REAR PANEL MOUNT CONNECTORS TO ALPHALINK SL SPRING LOADED CONTACT BOARD LEVEL (B/L) CONNECTOR

How To Order 891-041										
Sample Part Number	891-041	-19	P	S	01	-28	2	T	-12	S
Series / Basic Part No.	Series 89 Rectangular Nanominiature rear panel mount V/PTH to Series 171 AlphaLink SL									
I/O Contact Arrangement	See Table I									
Contact Type	P = Plug (See Table I) S = Receptacle (See Table III)									
I/O Shell Material and Finish	S = Stainless Steel, Passivated T = Titanium, Unplated									
I/O Gasket Material	Omit for no Gasket 01 = Fluorosilicone IAW MIL-DTL-25988, Type II, Class I, Grade 70 02 = Passivated Silver-Plated Aluminum filled Fluorosilicone IAW MIL-DTL-83528, Type "D" (CHO-Seal 1298 or equivalent)									
AlphaLink Layout	See Table II									
AlphaLink Finish	2 = Nickel 5 = Gold									
AlphaLink Hardware Option	T = Threaded thru hole Omit for thru hole									
Assembly Length (L)	3 = 3.00 ± .05 inches 6 = 6.00 ± .05 inches 12 = 12.00 ± .05 inches									
Optional Shielding	S = With shielding Omit for none									

MATERIALS AND FINISHES

B/L connector shell: Aluminum alloy.
 I/O shell: See P/N development
 I/O Insulator: LCP
 I/O Gasket: Fluorosilicone
 I/O Contacts: Gold Alloy per ASTM B477 and ASTM B541
 B/L Insulator: High Temp Thermoplastic
 B/L Contact: Copper Alloy/Gold Plated

NOTES

Input/Output Series 89 Nanominiature connector performance IAW MIL-DTL-32139
 As a minimum, assembly identified with date code, and Pin 1 identifier. Bag and tag with Glenair part number, CAGE code, and date code.
 Contacts mapped 1-to-1 from I/O to B/L connector (unused B/L contacts not connected). For alternative wire schedules, please consult factory.

Unused Cavities in I/O panel mount connector to be populated with contacts.

B/L AlphaLink SL interface dimensions IAW Glenair drawing 171-134-02. Interface shown for reference.

Unused cavities in B/L connector to be populated with contacts.

Flex Performance:

Shielding - EMI shielding film will be used when shielding option is chosen

Bend radius is 6 to 10 times the flex thickness.

Typical flex will be .01 ± .005 thick, rugged, potted, polyimide-based flex.

Flex cables are terminated from the I/O connector to the B/L connector on a 1 to 1 connection (unused B/L contacts are not connected)

Workmanship shall be IAW IPC-6013, Class 2.

Consult factory for more options and/or special designs and requirements



Rectangular Nanominiature rear-panel-mount plug to AlphaLink SL flex jumper

891-041 - Plug

SERIES 89 RECTANGULAR NANOMINIATURE INPUT/OUTPUT (I/O) REAR PANEL MOUNT PLUG TO ALPHALINK SL SPRING LOADED CONTACT BOARD LEVEL (B/L) CONNECTOR

Table I: Panel Mount Plug Insert Arrangement					
Size	A Bsc.	B Bsc.	C Bsc.	E	F
9	.270 (6.9)	.160 (4.1)	.566 (14.4)	.688 (17.5)	.808 (20.5)
15	.345 (8.8)	.235 (6.0)	.641 (16.3)	.736 (18.7)	.883 (22.4)
21	.420 (10.7)	.310 (7.9)	.716 (18.2)	.838 (21.3)	.958 (24.3)
25	.470 (11.9)	.360 (9.1)	.766 (19.5)	.888 (22.6)	1.008 (25.6)
31	.545 (13.8)	.435 (11.0)	.841 (21.4)	.963 (24.5)	1.083 (27.5)
37	.620 (15.7)	.510 (13.0)	.916 (23.3)	1.038 (26.4)	1.158 (29.4)
51	.795 (20.2)	.685 (17.4)	1.091 (27.7)	1.213 (30.8)	1.333 (33.9)

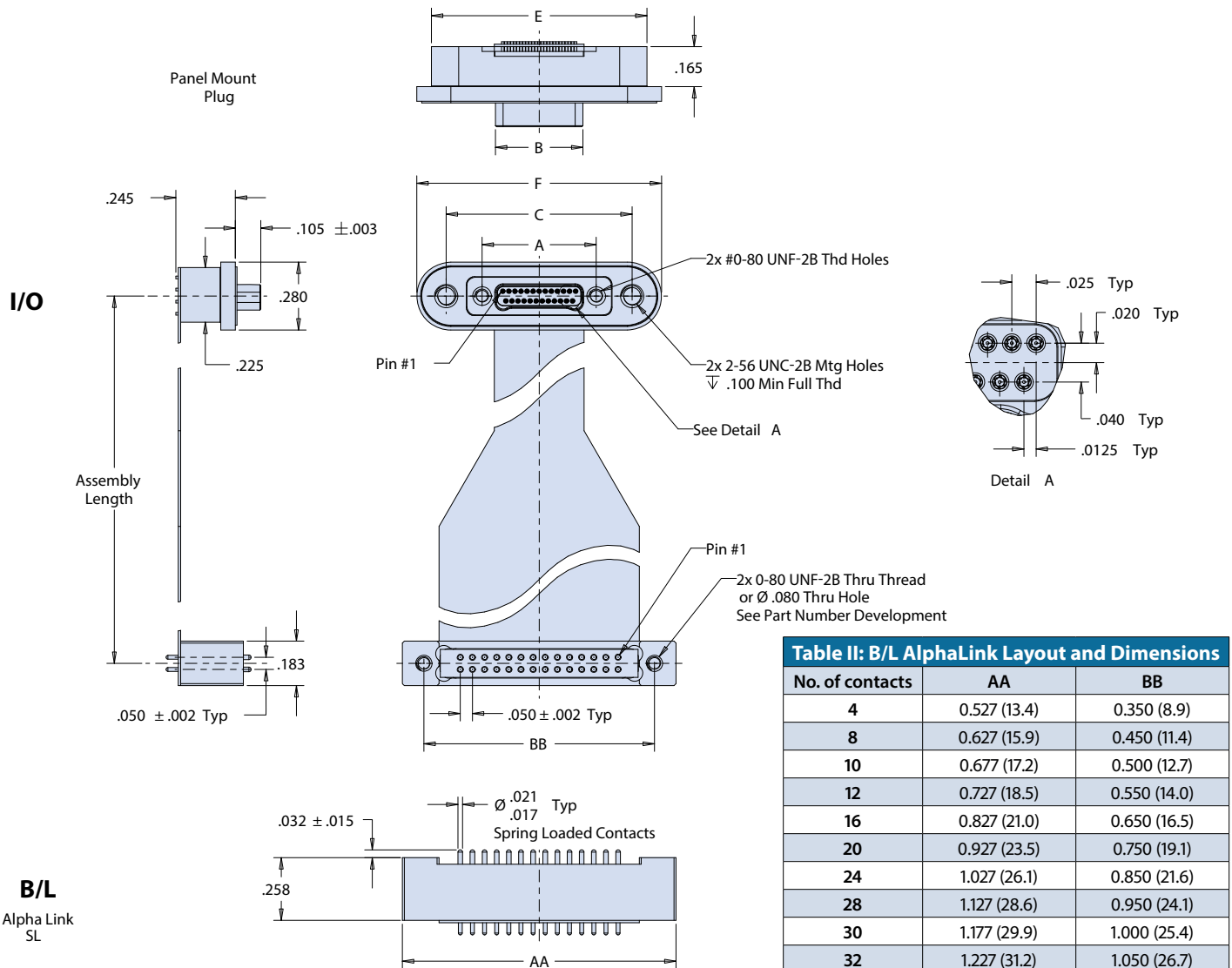

Table II: B/L AlphaLink Layout and Dimensions		
No. of contacts	AA	BB
4	0.527 (13.4)	0.350 (8.9)
8	0.627 (15.9)	0.450 (11.4)
10	0.677 (17.2)	0.500 (12.7)
12	0.727 (18.5)	0.550 (14.0)
16	0.827 (21.0)	0.650 (16.5)
20	0.927 (23.5)	0.750 (19.1)
24	1.027 (26.1)	0.850 (21.6)
28	1.127 (28.6)	0.950 (24.1)
30	1.177 (29.9)	1.000 (25.4)
32	1.227 (31.2)	1.050 (26.7)
36	1.327 (33.7)	1.150 (29.2)
40	1.427 (36.2)	1.250 (31.8)

Rectangular Nanominiature rear-panel-mount receptacle to AlphaLink SL flex jumper

891-041 - Receptacle

SERIES 89 RECTANGULAR NANOMINIATURE INPUT/OUTPUT (I/O) REAR PANEL MOUNT RECEPTACLE TO ALPHALINK SL SPRING LOADED CONTACT BOARD LEVEL (B/L) CONNECTOR

Table III: Panel Mount Receptacle Insert Arrangement						
Size	A Bsc	B Bsc.	C Bsc.	D	E	F
9	.270 (6.9)	.163 (4.1)	.566 (14.4)	.375 (9.5)	.688 (17.5)	.808 (20.5)
15	.345 (8.8)	.238 (6.0)	.641 (16.3)	.450 (11.4)	.736 (18.7)	.883 (22.4)
21	.420 (10.7)	.313 (8.0)	.716 (18.2)	.525 (13.3)	.838 (21.3)	.958 (24.3)
25	.470 (11.9)	.363 (9.2)	.766 (19.5)	.575 (14.6)	.888 (22.6)	1.008 (25.6)
31	.545 (13.8)	.438 (11.1)	.841 (21.4)	.650 (16.5)	.963 (24.5)	1.083 (27.5)
37	.620 (15.7)	.513 (13.0)	.916 (23.3)	.725 (18.4)	1.038 (26.4)	1.158 (29.4)
51	.795 (20.2)	.688 (17.5)	1.091 (27.7)	.900 (22.9)	1.213 (30.8)	1.333 (33.9)

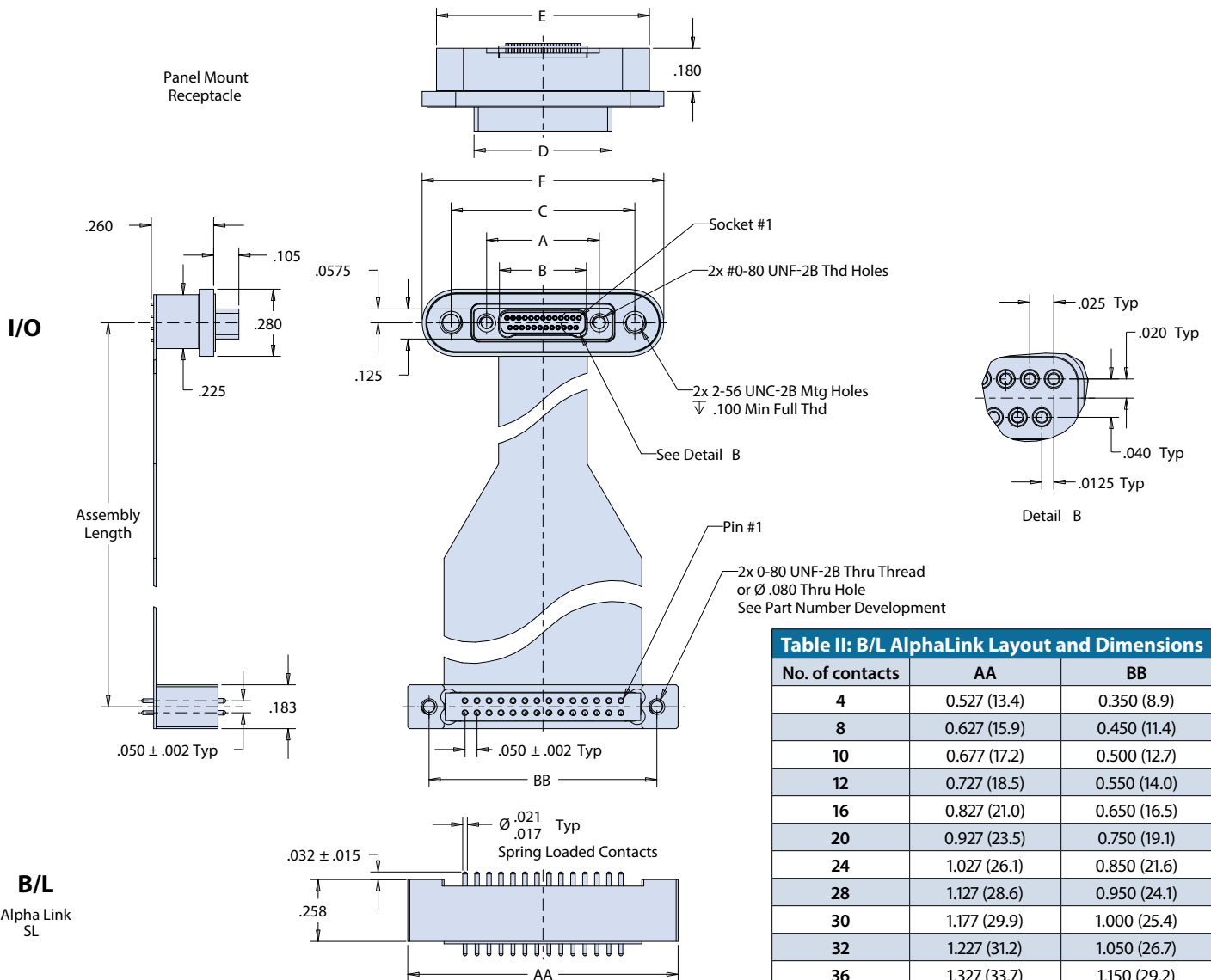



Micro-D to AlphaLink flex jumper

Micro-D to AlphaLink Flex Jumpers

High-reliability Micro-D MIL-DTL-83513 type rectangular connectors in 7 contact arrangements, terminated with rugged polyimide-based flex to high-performance AlphaLink SL board level connectors.

Recommended Micro-D I/O to AlphaLink Contact Arrangements*

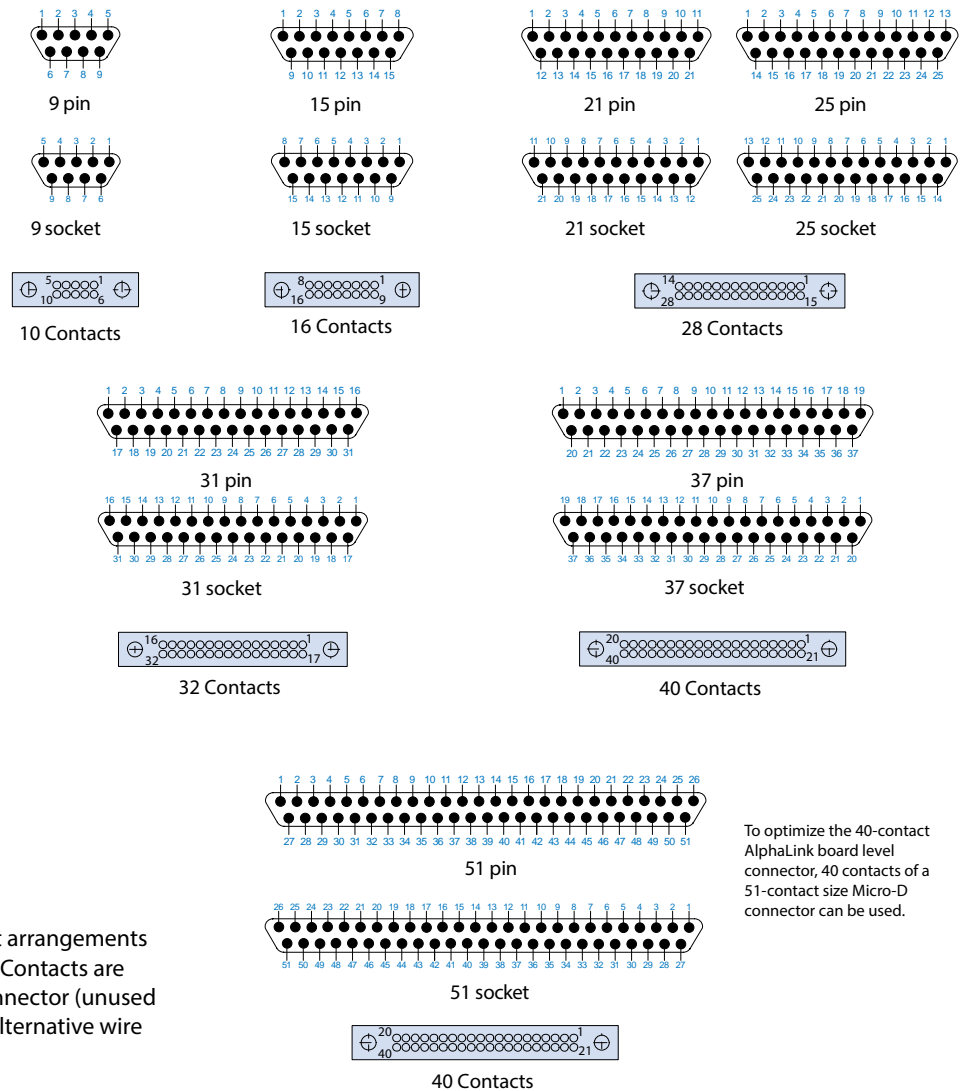

To optimize the 40-contact AlphaLink board level connector, 40 contacts of a 51-contact size Micro-D connector can be used.

* These are recommended contact arrangements only, but do offer best availability. Contacts are mapped 1-to-1 from I/O to B/L connector (unused B/L contacts not connected). For alternative wire schedules, please consult factory.

Table I - Shell Material/Finish	
Sym	Description
1	Aluminum Alloy-Cadmium
2	Aluminum Alloy-Electroless Nickel
3	Stainless Steel-Pasivated
5	Aluminum Alloy-Gold
33	Aluminum Alloy-Ni/Pfte

Table III- I/O Hardware Options	
Sym	Description (Rear Panel Mount)
R1	Jackpost for .032 Thick Panel
R2	Jackpost for .047 Thick Panel
R3	Jackpost for .062 Thick Panel
R4	Jackpost for .093 Thick Panel
R5	Jackpost for .125 Thick Panel
R6	Jackpost for .080 Thick Panel

Table II (I/O Connector Dimensions)							
Shell Size	A ±.005	B ±.003	C Max	D Max	E±.003	F±.005	G±.005
9P	.960 (24.4)	.565 (14.4)	.334 (8.5)	.184 (4.7)	.183 (4.6)	.529 (13.4)	.775 (19.7)
9S	.960 (24.4)	.565 (14.4)	.400 (10.2)	.250 (6.4)	.195 (5.0)	.541 (13.7)	.775 (19.7)
15P	1.110 (28.2)	.715 (18.2)	.484 (12.3)	.184 (4.7)	.183 (4.6)	.529 (13.4)	.925 (23.5)
15S	1.110 (28.2)	.715 (18.2)	.550 (14.0)	.250 (6.4)	.195 (5.0)	.541 (13.7)	.925 (23.5)
21P	1.260 (32.0)	.865 (22.0)	.634 (16.1)	.184 (4.7)	.183 (4.6)	.529 (13.4)	1.075 (27.3)
21S	1.260 (32.0)	.865 (22.0)	.700 (17.8)	.250 (6.4)	.195 (5.0)	.541 (13.7)	1.075 (27.3)
25P	1.360 (34.5)	.965 (24.5)	.734 (18.6)	.184 (4.7)	.183 (4.6)	.529 (13.4)	1.175 (29.8)
25S	1.360 (34.5)	.965 (24.5)	.800 (20.3)	.250 (6.4)	.195 (5.0)	.541 (13.7)	1.175 (29.8)
31P	1.510 (38.4)	1.115 (28.3)	.884 (22.5)	.184 (4.7)	.183 (4.6)	.529 (13.4)	1.325 (33.7)
31S	1.510 (38.4)	1.115 (28.3)	.950 (24.1)	.250 (6.4)	.195 (5.0)	.541 (13.7)	1.325 (33.7)
37P	1.660 (42.2)	1.265 (32.1)	1.034 (26.3)	.184 (4.7)	.183 (4.6)	.529 (13.4)	1.473 (37.4)
37S	1.660 (42.2)	1.265 (32.1)	1.100 (27.9)	.250 (6.4)	.195 (5.0)	.541 (13.7)	1.473 (37.4)
51P	2.035 (51.7)	1.615 (41.0)	1.384 (35.2)	.228 (5.8)	.183 (4.6)	.529 (13.4)	1.990 (50.5)
51S	2.035 (51.7)	1.615 (41.0)	1.450 (36.8)	.296 (7.5)	.195 (5.0)	.541 (13.7)	1.990 (50.5)

* Contacts mapped 1-to-1 from I/O to B/L connector (unused B/L contacts not connected). For alternative wire schedules, please consult factory.

Table IV - B/L Connector Dimensions		
Layout	AA	BB
4	.527 (13.4)	.350 (8.9)
8	.627 (15.9)	.450 (11.4)
10	.677 (17.2)	.500 (12.7)
16	.827 (21.0)	.650 (16.5)
20	.927 (23.5)	.750 (19.1)
28	1.127 (28.6)	.950 (24.1)
32	1.227 (31.2)	1.050 (26.7)
40	1.427 (36.2)	1.250 (31.8)

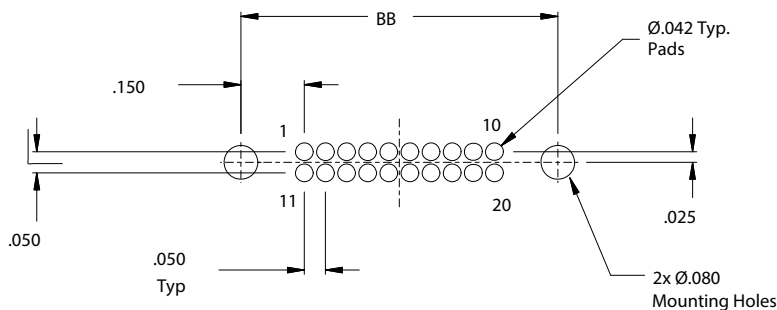

Recommended PCB Layout
(See Table IV)



Rear panel mount environmental Micro-D connector to AlphaLink SL flex jumper

1770-2449

GRPM PANEL-MOUNT MICRO-D INPUT/OUTPUT (I/O) CONNECTOR TO ALPHALINK SL SPRING LOADED CONTACT BOARD LEVEL (B/L) CONNECTOR

How To Order 1770-2449										
Sample Part Number	1770-2449	2	-15	S	R1	-16	2	T	-6	S
Series / Basic Part No.	GRPM Panel-Mount Micro-D I/O connector to Series 171 AlphaLink SL									
I/O Material / Finish	See Table I									
I/O Connector Shell Size	-9, -15, -21, -25, -31, -37, -51 (See Table II)									
I/O Contact Style	P = Pin/Plug S = Socket/Receptacle									
I/O Hardware Option	R1 = Jackpost for .032 Thick Panel R2 = Jackpost for .047 Thick Panel R3 = Jackpost for .062 Thick Panel R4 = Jackpost for .093 Thick Panel R5 = Jackpost for .125 Thick Panel R6 = Jackpost for .080 Thick Panel									
AlphaLink Shell size	-4, -8, -10, -16, -20, -28, -32, -40 (See Table IV)									
AlphaLink Finish	2 = Nickel 5 = Gold									
AlphaLink Hardware Option	T = Threaded thru hole Omit for thru hole									
Assembly Length	3 = 3.00 ± .05 inches 6 = 6.00 ± .05 inches 12 = 12.00 ± .05 inches									
Optional Shielding	S = With shielding Omit for none									

Sym	Description
1	Aluminum Alloy-Cadmium
2	Aluminum Alloy-Electroless Nickel
3	Stainless Steel-Pasivated
5	Aluminum Alloy-Gold
33	Aluminum Alloy-Ni/Pfte

MATERIALS AND FINISHES

B/L connector shell: Aluminum alloy. I/O shell: See Table I
 Insulator: High-grade rigid dielectric
 Socket interfacial seal: Fluorosilicone
 Contacts: Copper Alloy/Gold Plated
 Potting: Epoxy
 Hardware: Stainless steel/passivated

NOTES

Input/Output Micro-D rectangular environmental connector:
 I/O connector designed to meet the performance requirements of MIL-DTL-83513 (MWDM series)
 I/O interface dimensions IAW MIL-DTL-83513
 Unused cavities in I/O connector to be populated with contacts IAW MIL-DTL-83513
 Contacts mapped 1-to-1 from I/O to B/L connector (unused B/L contacts not connected). For alternative wire schedules, please consult factory.

Board Level AlphaLink SL connector:

B/L AlphaLink SL connectors are built in accordance with Glenair drawing 171-134-02
 B/L connectors are paired with I/O connectors as shown in Contact Arrangements diagram, page 32

Flex Performance:

Shielding - EMI shielding film.
 Bend radius is 6 to 10 times the flex thickness.
 Typical flex will be .01 ± .005 thick, rugged, potted, polyimide-based flex.
 Flex cables are terminated from the I/O connector to the B/L connector on a 1 to 1 connection (unused B/L contacts are not connected)
 Workmanship shall be IAW IPC-6013, Class 2.

Consult factory for more options and/or special designs and requirements

Rear panel mount environmental Micro-D connector to AlphaLink SL flex jumper

1770-2449

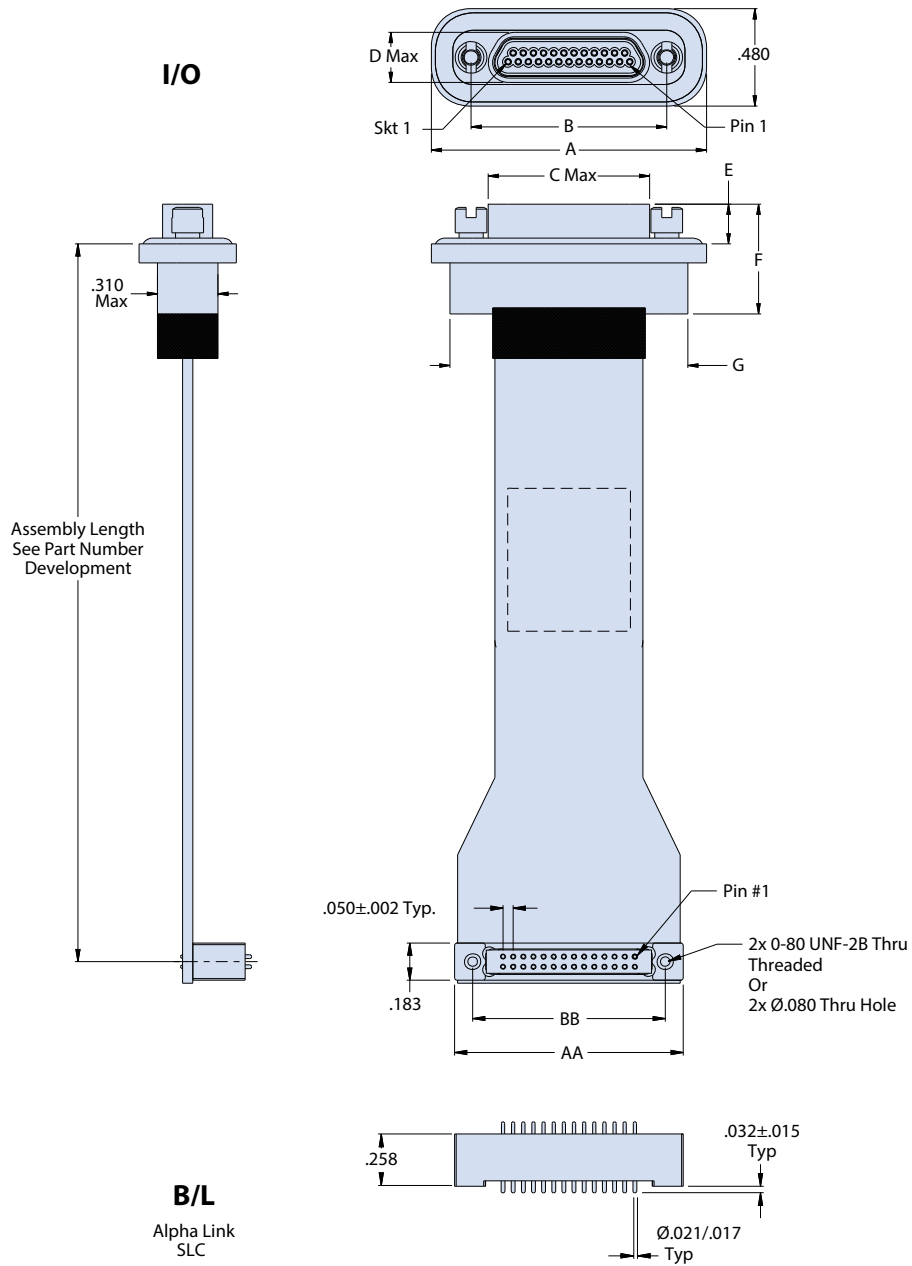

SERIES 28 HIPER-D TO ALPHALINK® FLEX JUMPERS
 Contact arrangements • materials and finishes •
 hardware options • dimensions • PCB layout



HiPer-D to AlphaLink® flex jumper

HiPer-D to AlphaLink® Flex Jumpers

High-reliability HiPer-D MIL-DTL-24308 intermateable/intermountable rectangular connectors in 6 contact arrangements, terminated with rugged polyimide-based flex to high-performance AlphaLink® SL board level connectors.

Recommended HiPer-D I/O to AlphaLink Contact Arrangements*

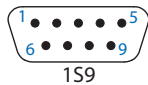

1S9



8 Contacts

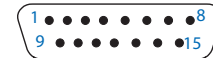

2S15

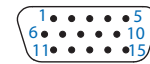

1H15

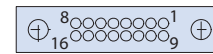

16 Contacts

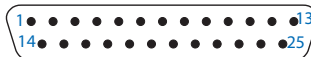

3S25

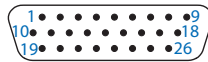

2H26



28 Contacts

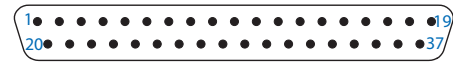

4S37

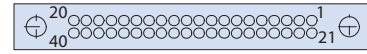

40 Contacts

Table II - Available I/O Insert Layout and B/L Assembly Pair			
Insert Layout	I/O Insert Layout		B/L Layout
	Contact Size	Qty.	
1S9	20HD	5	8
2S15	20HD	15	16
3S25	20HD	25	28
4S37	20HD	37	40
1H15	22D	15	16
2H26	22D	26	28

* These are recommended contact arrangements only, but do offer best availability. Contacts are mapped 1-to-1 from I/O to B/L connector (unused B/L or I/O contacts not connected). For alternative wire schedules, please consult factory.



Sym	Description
2	Aluminum Alloy-Electroless Nickel
5	Aluminum Alloy-Gold

Layout	AA	BB
8	.627 (15.9)	.450 (11.4)
16	.827 (21.0)	.650 (16.5)
28	1.127 (28.6)	.950 (24.1)
40	1.427 (36.2)	1.250 (31.8)

* Contacts mapped 1-to-1 from I/O to B/L connector (unused B/L or I/O contacts not connected). For alternative wire schedules, please consult factory.

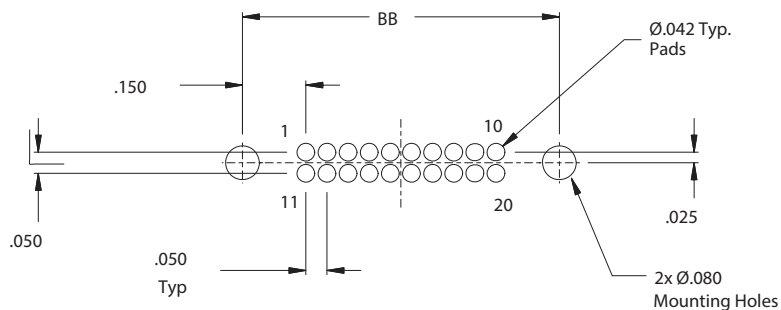

Recommended PCB Layout
(See Table IV)

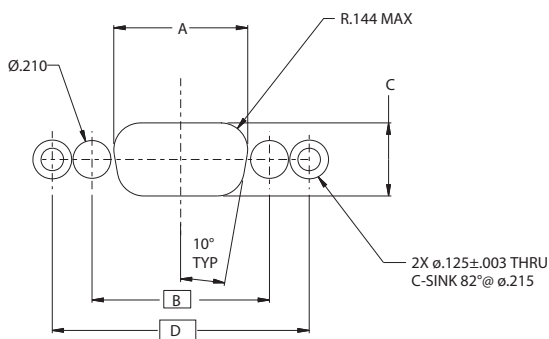

Recommended Panel Cutout
as viewed from front face of panel

Shell Size	A +.005 -.000	B Bsc	C +.005 -.000	D Bsc
1	.746 (18.9)	.984 (25.0)	.409 (10.4)	1.424 (36.2)
2	1.074 (27.3)	1.312 (33.3)	.409 (10.4)	1.752 (44.5)
3	1.614 (41.0)	1.852 (47.0)	.409 (10.4)	2.292 (58.2)
4	2.262 (57.5)	2.500 (63.5)	.409 (10.4)	2.940 (74.7)

HiPer-D pin connector to AlphaLink® SL flex jumper

286-077P

HIPER-D (I/O) PIN CONNECTOR TO ALPHALINK® SL SPRING LOADED CONTACT BOARD LEVEL (B/L) CONNECTOR

How To Order 286-077P	
Sample Part Number	286-077P -3S25 ME G N -2 T -6 S
Series / Basic Part No.	HiPer-D pin connector to Series 171 AlphaLink® SL
I/O Insert Arrangement	See Table II
I/O Material / Finish	ME = Electroless Nickel over Aluminum Z1 = Passivated Stainless ZM = Electroless Nickel over Stainless JF = Yellow Chromate over Cadmium
I/O Grounding Option	G = EMI Grounding N = None
I/O Hardware Option	N = None (Tapped Hole) P = Female Jackpost G = Guide Pin B = Guide Bushing
AlphaLink® Finish	2 = Nickel 5 = Gold
AlphaLink® Hardware Option	T = Threaded thru hole Omit for thru hole
Assembly Length	3 = 3.00 ± .05 inches 6 = 6.00 ± .05 inches 12 = 12.00 ± .05 inches
Optional Shielding	S = With shielding Omit for none

NOTES

Input/Output Series 28 HiPer-D connector:

Right-angle pin-contact connector, rear panel mount with o-ring environmental seal.
Refer to Glenair drawing 280-024 for materials, finishes, and performance specifications.
Contacts mapped 1-to-1 from I/O to B/L connector (unused B/L contacts not connected). For alternative wire schedules, please consult factory.

Board Level AlphaLink® SL connector:

B/L AlphaLink® SL connectors are built in accordance with Glenair drawing 171-134-02

Flex Performance:

Shielding - EMI shielding film.
Bend radius is 6 to 10 times the flex thickness.
Typical flex will be .01 ± .005 thick, rugged, potted, polyimide-based flex.
Flex cables are terminated from the I/O connector to the B/L connector on a 1 to 1 connection (unused B/L contacts are not connected)
Workmanship shall be IAW IPC-6013, Class 2.
Consult factory for more options and/or special designs and requirements

HiPer-D plug connector to AlphaLink® SL flex jumper

286-077P

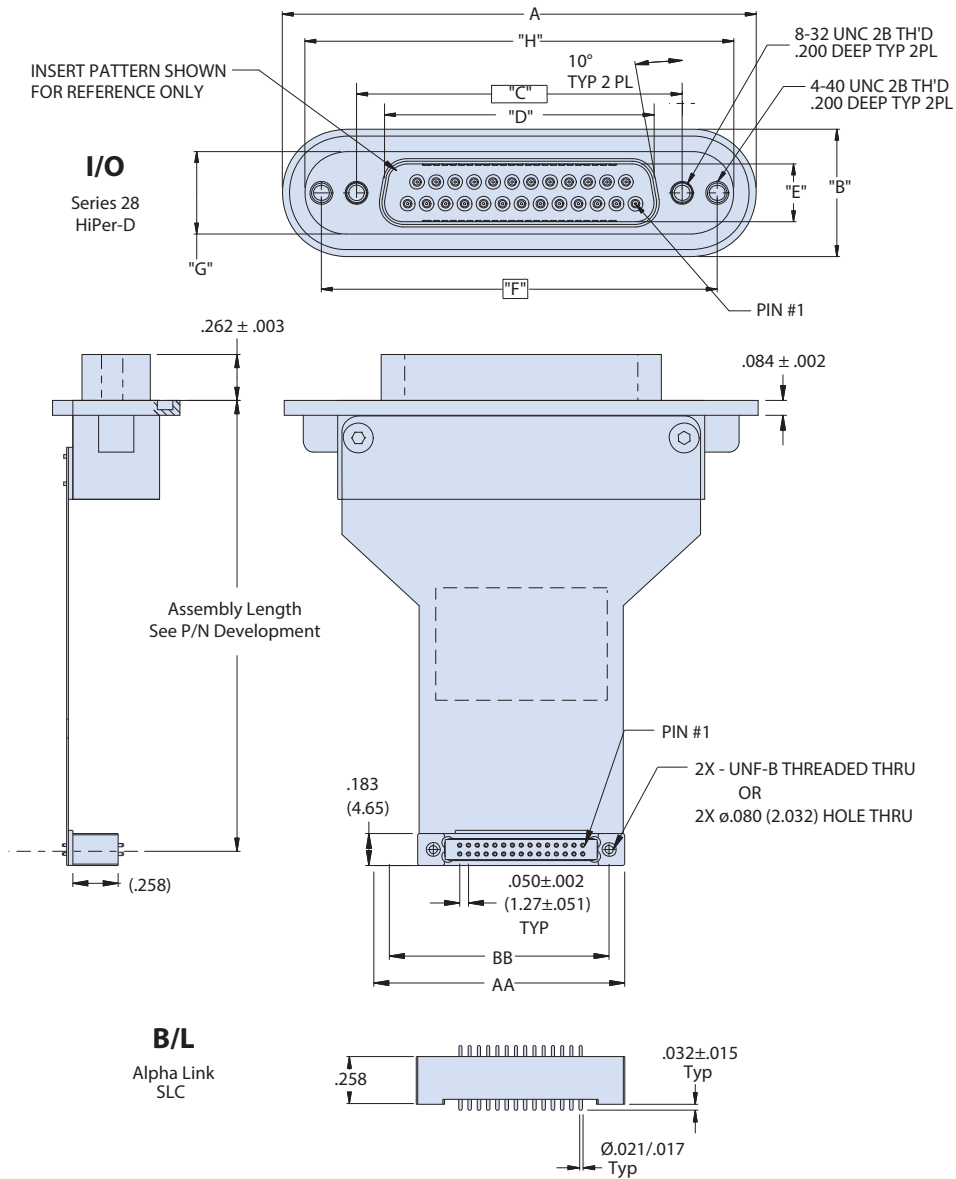

Table II (I/O Connector Dimensions)									
Shell Size	Insert Pattern	A ± .015	B ± .015	C Basic	D ± .005	E ± .005	F Basic	G ± .015	H ± .015
1	SD9	1.865 (47.4)	0.725 (18.4)	0.984 (25.0)	0.666 (16.9)	0.329 (8.4)	1.424 (36.2)	0.469 (11.9)	1.609 (40.9)
	HD15								
2	SD15	2.200 (55.9)	0.725 (18.4)	1.312 (33.3)	0.994 (25.2)	0.329 (8.4)	1.752 (44.5)	0.469 (11.9)	1.944 (49.4)
	HD26								
3	SD25	2.736 (69.5)	0.725 (18.4)	1.852 (47.0)	1.534 (39.0)	0.329 (8.4)	2.292 (58.2)	0.469 (11.9)	2.480 (63.0)
4	SD37	3.385 (86.0)	0.725 (18.4)	2.500 (63.5)	2.182 (55.4)	0.329 (8.4)	2.940 (74.7)	0.469 (11.9)	3.129 (79.5)

HiPer-D socket connector to AlphaLink® SL flex jumper

286-078S

HIPER-D (I/O) SOCKET CONNECTOR TO ALPHALINK® SL SPRING LOADED CONTACT BOARD LEVEL (B/L) CONNECTOR

How To Order 286-078S	
Sample Part Number	286-078S -3S25 ME N -2 T -6 S
Series / Basic Part No.	HiPer-D socket connector to Series 171 AlphaLink® SL
I/O Insert Arrangement	See Table II
I/O Material / Finish	ME = Electroless Nickel over Aluminum Z1 = Passivated Stainless ZM = Electroless Nickel over Stainless JF = Yellow Chromate over Cadmium
I/O Hardware Option	N = None (Tapped Hole) P = Female Jackpost G = Guide Pin B = Guide Bushing
AlphaLink® Finish	2 = Nickel 5 = Gold
AlphaLink® Hardware Option	T = Threaded thru hole Omit for thru hole
Assembly Length	3 = 3.00 ± .05 inches 6 = 6.00 ± .05 inches 12 = 12.00 ± .05 inches
Optional Shielding	S = With shielding Omit for none

NOTES

Input/Output Series 28 HiPer-D connector:

- Right-angle socket-contact connector, rear panel mount with o-ring environmental seal.
- Refer to Glenair drawing 280-025 for materials, finishes, and performance specifications.
- Contacts mapped 1-to-1 from I/O to B/L connector (unused B/L contacts not connected). For alternative wire schedules, please consult factory.

Board Level AlphaLink® SL connector:

- B/L AlphaLink® SL connectors are built in accordance with Glenair drawing 171-134-02

Flex Performance:

- Shielding - EMI shielding film.
- Bend radius is 6 to 10 times the flex thickness.
- Typical flex will be .01 ± .005 thick, rugged, potted, polyimide-based flex.
- Flex cables are terminated from the I/O connector to the B/L connector on a 1 to 1 connection (unused B/L contacts are not connected)
- Workmanship shall be IAW IPC-6013, Class 2.
- Consult factory for more options and/or special designs and requirements

HiPer-D receptacle connector to AlphaLink® SL flex jumper

286-078S

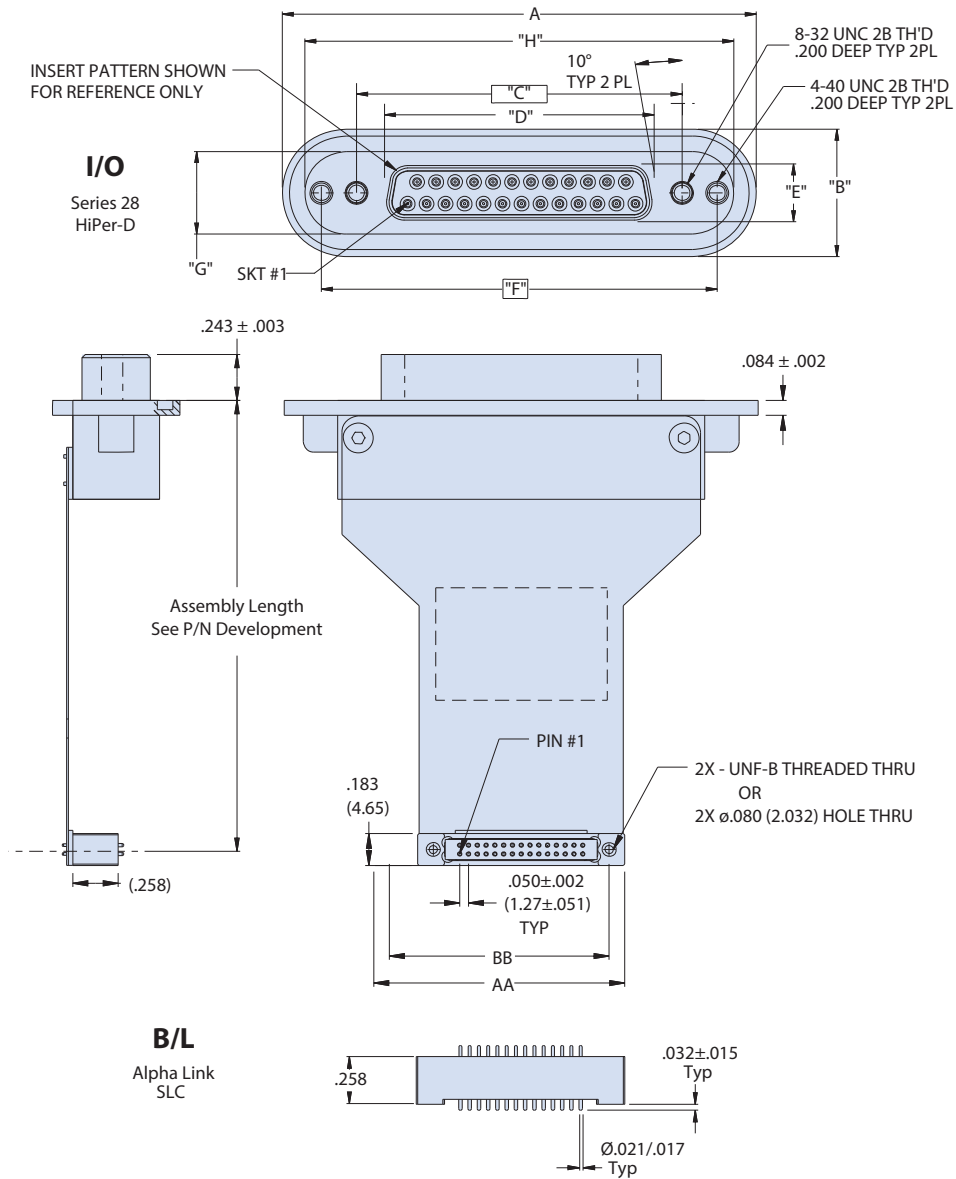

Table II (I/O Connector Dimensions)									
Shell Size	Insert Pattern	A ± .015	B ± .015	C Basic	D ± .005	E ± .005	F Basic	G ± .015	H ± .015
1	SD9	1.865 (47.4)	0.725 (18.4)	0.984 (25.0)	0.643 (16.3)	0.311 (7.9)	1.424 (36.2)	0.469 (11.9)	1.609 (40.9)
	HD15								
2	SD15	2.200 (55.9)	0.725 (18.4)	1.312 (33.3)	0.971 (24.7)	0.311 (7.9)	1.752 (44.5)	0.469 (11.9)	1.944 (49.4)
	HD26								
3	SD25	2.736 (69.5)	0.725 (18.4)	1.852 (47.0)	1.511 (38.4)	0.311 (7.9)	2.292 (58.2)	0.469 (11.9)	2.480 (63.0)
4	SD37	3.385 (86.0)	0.725 (18.4)	2.500 (63.5)	2.159 (54.8)	0.311 (7.9)	2.940 (74.7)	0.469 (11.9)	3.129 (79.5)



Micro-Crimp to AlphaLink Flex Jumpers

Glenair Series 79 Micro-Crimp advanced-performance rectangular connectors in 7 contact arrangements, terminated with rugged polyimide-based flex to AlphaLink board level connectors.



Micro-Crimp to AlphaLink flex jumper

Recommended Micro-Crimp I/O to AlphaLink Contact Arrangements*

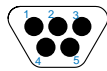

A-5



8 Contacts

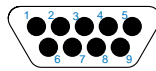

B-9

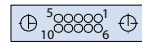

10 Contacts

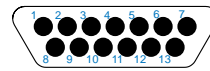

C-13



16 Contacts

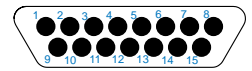

D-15

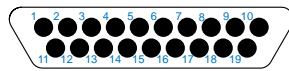

E-19



20 Contacts

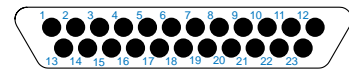

F-23



28 Contacts

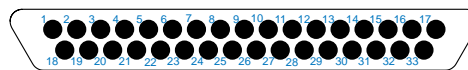

J-33



40 Contacts

* These are recommended contact arrangements only, but do offer best availability. Contacts are mapped 1-to-1 from I/O to B/L connector (unused B/L contacts not connected). For alternative wire schedules, please consult factory.

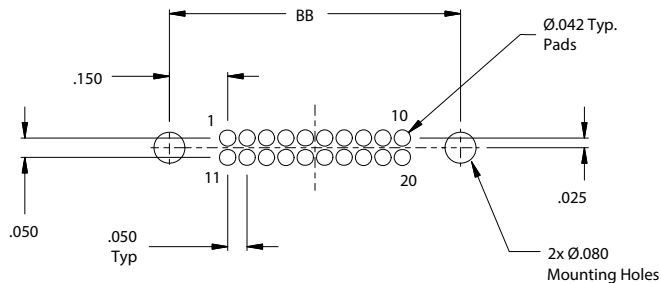

Recommended PCB Layout (See Table IV)

H

Contact arrangements • hardware options • dimensions • PCB layout



Table I: Hardware Option		
N No Mating Hardware		Connector supplied with blind tapped holes. .150" (3.8 mm) minimum depth. Connector supplied with blind tapped holes, .150 (3.8mm) minimum depth, #4-40 UNC-2B thread.
P Jackposts		Connector is supplied with non-removable stainless steel jackposts, #2-56 UNC-2B thread.
G Guide Pins		Connector is supplied with stainless steel non-removable guide pins for blind mate applications. Mates with type "S" guide sockets on corresponding plug connector.
S Guide Sockets		Connector is supplied with stainless steel non-removable bushings for blind mate applications. Mates with type "G" guide pins on corresponding plug connector.

Table II: Available I/O Insert Layout and B/L Assembly Pair

I/O No. of Contacts	I/O Insert Layout		B/L No. of Contacts
	Contact Size	Config	
5	23	A-5	8
9	23	B-9	10
13	23	C-13	16
15	23	D-15	16
19	23	E-19	20
23	23	F-23	28
33	23	J-33	40

* Contacts mapped 1-to-1 from I/O to B/L connector (unused B/L contacts not connected). For alternative wire schedules, please consult factory.

Table IV - B/L Connector Dimensions

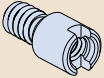
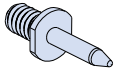
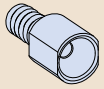
Layout	AA	BB
4	.527 (13.4)	.350 (8.9)
8	.627 (15.9)	.450 (11.4)
10	.677 (17.2)	.500 (12.7)
16	.827 (21.0)	.650 (16.5)
20	.927 (23.5)	.750 (19.1)
28	1.127 (28.6)	.950 (24.1)
32	1.227 (31.2)	1.050 (26.7)
40	1.427 (36.2)	1.250 (31.8)



Rear panel mount environmental Micro-Crimp pin contact receptacle to AlphaLink SL flex jumper

796-112

SERIES 79 MICRO-CRIMP INPUT/OUTPUT (I/O) RECEPTACLE CONNECTOR WITH PIN CONTACTS TO ALPHALINK SL SPRING-LOADED CONTACT BOARD LEVEL (B/L) CONNECTOR

How To Order 796-112	
Sample Part Number	796-112 -9-10 M G -2 T -6 S
Series / Basic Part No.	Rear Panel-Mount Micro-Crimp I/O receptacle to Series 171 AlphaLink SL
I/O Contact Arrangement	See Table II
I/O Shell Finish	Aluminum Shell M - Electroless Nickel MT - Nickel-PTFE E - Chem Film Z2 - Gold UC - Zinc Cobalt with Black Chromate J - Cadmium with Yellow Chromate NF - Cad/O.D. over Electroless Nickel
I/O Hardware Option	P - Jackposts G - Male Guide Pins S - Female Guide Sockets N - No Mating Hardware (See Table I)
AlphaLink Finish	2 = Nickel 5 = Gold
AlphaLink Hardware Option	T = Threaded thru hole Omit for thru hole
Assembly Length	3 = 3.00 ± .05 inches 6 = 6.00 ± .05 inches 12 = 12.00 ± .05 inches
Optional Shielding	S = With shielding Omit for none

MATERIALS AND FINISHES

Shell: Aluminum alloy
 Insulators: Liquid crystal polymer
 Interfacial seal: Fluorosilicone
 Contacts: Copper Alloy/Gold Plated
 Potting: Epoxy
 Hardware: 300 series stainless steel

NOTES

Input/Output Series 79 Micro-Crimp connector:
 Receptacle connector with pin contacts, rear panel mount with o-ring environmental seal
 Refer to Glenair drawing 799-009 for insert arrangements
 Contacts mapped 1-to-1 from I/O to B/L connector (unused B/L contacts not connected). For alternative wire schedules, please consult factory.
 Refer to Glenair drawing 799-008 for materials, finishes and performance specifications
 Refer to Glenair drawing 799-005 for panel cutouts
 Blind mate ± .030 (0.76) allowable misalignment from centerline.

Board Level AlphaLink SL connector:

B/L AlphaLink SL connectors are built in accordance with Glenair drawing 171-134-02
 B/L connectors are paired with I/O connectors as shown in Contact Arrangements diagram, page 36

Flex Performance:

Shielding - EMI shielding film.
 Bend radius is 6 to 10 times the flex thickness.
 Typical flex will be .01 ± .005 thick, rugged, potted, polyimide-based flex.
 Flex cables are terminated from the I/O connector to the B/L connector on a 1 to 1 connection (unused B/L contacts are not connected)
 Workmanship shall be IAW IPC-6013, Class 2.

Consult factory for more options and/or special designs and requirements

H

Rear panel mount environmental Micro-Crimp pin contact receptacle to AlphaLink SL flex jumper

796-112

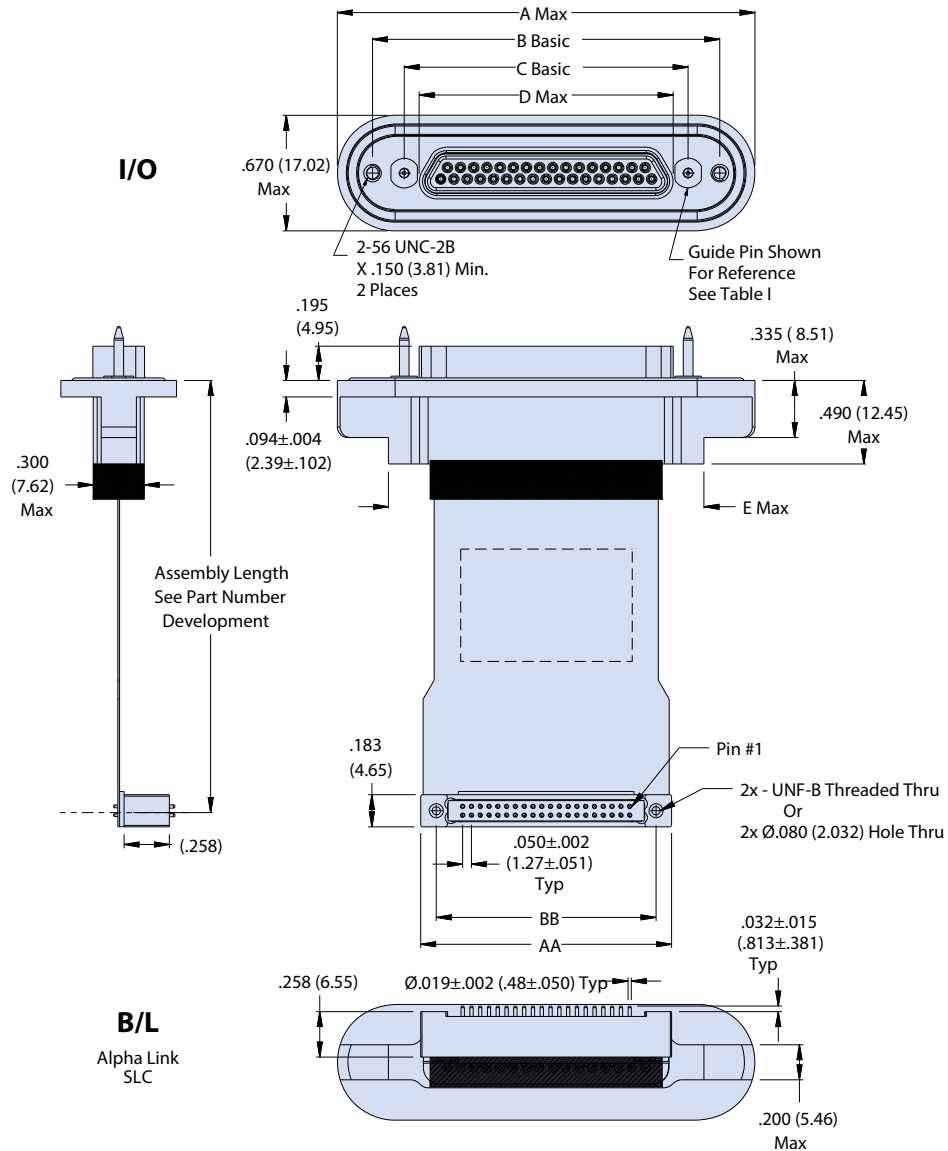

Micro-Crimp I/O Connector Shell Size/Dimensions										
Shell Size	A Max		B Basic		C Basic		D Max		E Max	
	In.	mm.	In.	mm.	In.	mm.	In.	mm.	In.	mm.
A	1.341	34.06	.925	23.50	.565	14.35	.401	10.19	.760	19.30
B	1.491	37.87	1.075	27.31	.715	18.16	.551	14.00	.910	21.11
C	1.641	41.68	1.225	31.12	.865	21.97	.701	17.81	1.060	26.92
D	1.741	44.22	1.325	33.66	.965	24.51	.801	20.35	1.160	29.46
E	1.891	48.03	1.475	37.47	1.115	28.32	.951	24.16	1.310	33.27
F	2.041	51.84	1.625	41.28	1.265	32.13	1.101	27.96	1.460	37.08
J	2.391	60.73	1.975	50.17	1.615	41.02	1.460	37.08	1.810	45.97



Rear panel mount environmental Micro-Crimp socket contact plug to AlphaLink SL flex jumper

796-113

SERIES 79 MICRO-CRIMP INPUT/OUTPUT (I/O) PLUG CONNECTOR WITH SOCKET CONTACTS TO ALPHALINK SL SPRING-LOADED CONTACT BOARD LEVEL (B/L) CONNECTOR

How To Order 796-113									
Sample Part Number	796-113	-9-10	M	E	G	-2	T	-6	S
Series / Basic Part No.	Rear Panel-Mount Micro-Crimp I/O plug to Series 171 AlphaLink SL								
I/O Contact Arrangement	See Table II								
I/O Shell Finish	Aluminum Shell M - Electroless Nickel MT - Nickel-PTFE E - Chem Film Z2 - Gold UC - Zinc Cobalt with Black Chromate J - Cadmium with Yellow Chromate NF - Cad/O.D. over Electroless Nickel								
EMI Spring	E = EMI Spring N = No EMI Spring								
I/O Hardware Option	P - Jackposts G - Male Guide Pins S - Female Guide Sockets N - No Mating Hardware (See Table I)								
AlphaLink Finish	2 = Nickel 5 = Gold								
AlphaLink Hardware Option	T = Threaded thru hole Omit for thru hole								
Assembly Length	3 = 3.00 ± .05 inches 6 = 6.00 ± .05 inches 12 = 12.00 ± .05 inches								
Optional Shielding	S = With shielding Omit for none								

MATERIALS AND FINISHES

Shell: Aluminum alloy
 Insulators: Liquid crystal polymer
 Interfacial seal: Fluorosilicone
 Contacts: Copper Alloy/Gold Plated
 Potting: Epoxy
 Hardware: 300 series stainless steel

NOTES

Input/Output Series 79 Micro-Crimp connector:
 Plug connector with socket contacts, rear panel mount with o-ring environmental seal
 Refer to Glenair drawing 799-009 for insert arrangements
 Refer to Glenair drawing 799-008 for materials, finishes and performance specifications
 Refer to Glenair drawing 799-005 for panel cutouts
 Blind mate ± .030 (0.76) allowable misalignment from centerline.

Board Level AlphaLink SL connector:

B/L AlphaLink SL connectors are built in accordance with Glenair drawing 171-134-02
 B/L connectors are paired with I/O connectors as shown in Contact Arrangements diagram, page 36

Flex Performance:

Shielding - EMI shielding film.
 Bend radius is 6 to 10 times the flex thickness.
 Typical flex will be .01 ± .005 thick, rugged, potted, polyimide-based flex.
 Flex cables are terminated from the I/O connector to the B/L connector on a 1 to 1 connection (unused B/L contacts are not connected)
 Workmanship shall be IAW IPC-6013, Class 2.
 Consult factory for more options and/or special designs and requirements

Rear panel mount environmental Micro-Crimp socket contact plug to AlphaLink SL flex jumper

796-113

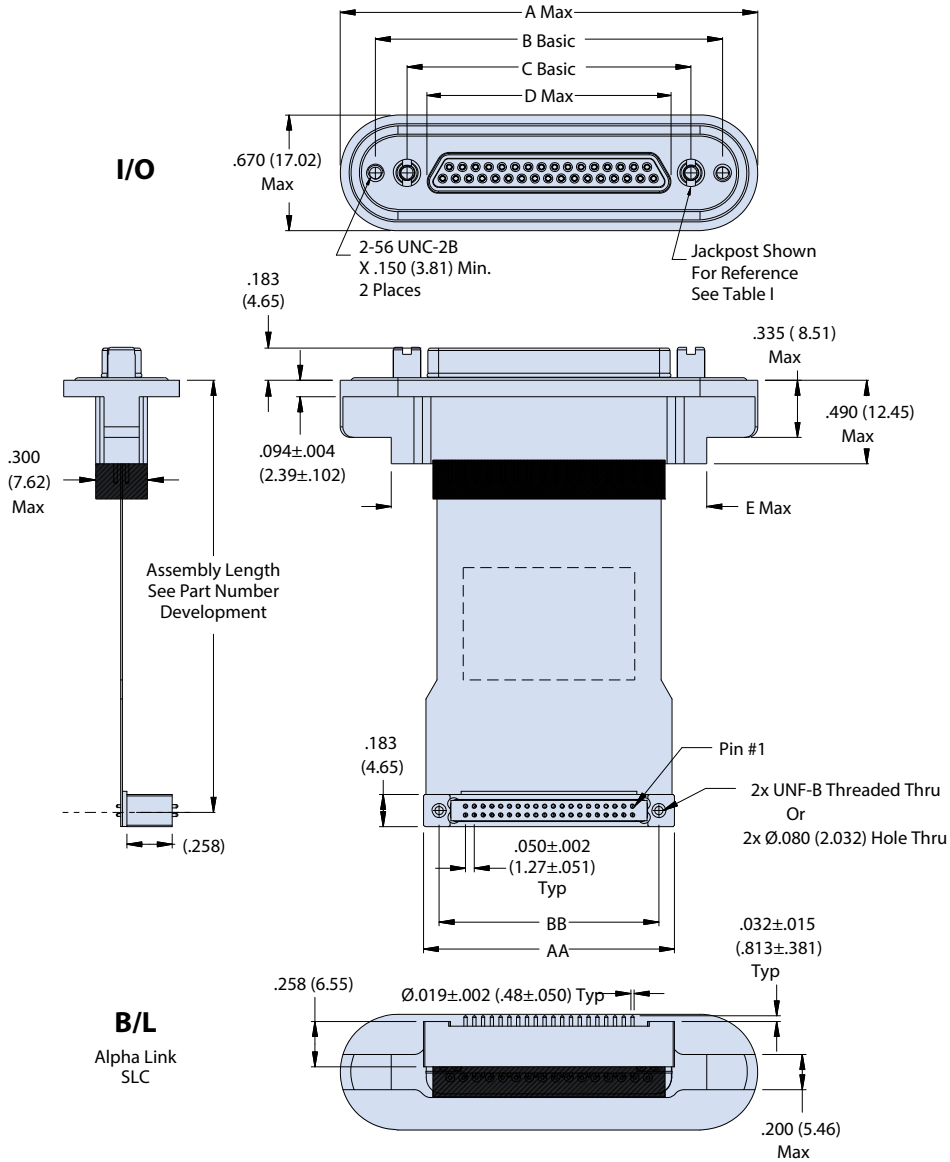

Micro-Crimp I/O Connector Shell Size/Dimensions										
Shell Size	A Max		B Basic		C Basic		D Max		E Max	
	In.	mm.	In.	mm.	In.	mm.	In.	mm.	In.	mm.
A	1.341	34.06	.925	23.50	.565	14.35	.335	8.51	.760	19.30
B	1.491	37.87	1.075	27.31	.715	18.16	.485	12.32	.910	21.11
C	1.641	41.68	1.225	31.12	.865	21.97	.635	16.13	1.060	26.92
D	1.741	44.22	1.325	33.66	.965	24.51	.735	18.67	1.160	29.46
E	1.891	48.03	1.475	37.47	1.115	28.32	.885	22.48	1.310	33.27
F	2.041	51.84	1.625	41.28	1.265	32.13	1.035	26.29	1.460	37.08
J	2.391	60.73	1.975	50.17	1.615	41.02	1.390	35.31	1.810	45.97





SERIES M22759

Data transmission wire

AS22759 qualified single-ended transmission wire for termination of AlphaLink SL solder-cup connectors

Glenair stocks a full range of AS22759 qualified wire and cable. M22759/11 is a general-purpose, high-temperature range silver-coated copper wire with extruded TFE insulation. M22759/33 is our small diameter high-flex silver-coated copper wire with crosslinked modified ETFE insulation. Both are offered in #24 AWG, optimized for termination to AlphaLink 171-134-01 solder-cup spring-loaded board level connectors.

Part Number	Wire Size (AWG)	Stranding (Number of strands x AWG gage of strands)	Diameter of stranded conductor (inches)		Finished Wire		
			min	max	Resistance at 20° C (68° F) (Ohms/ 1000 ft) max	Diameter (inches)	Weight (lbs/ 1000 ft) max
M22759/11-24-*	24	19 x 36	.023	.025	24.3	.043 ± .002	2.58
M22759/33-24-*	24	19 x 36	.023	.025	28.4	.037 ± .002	2.0

NOTES

Cable identified with manufacturer's name and part number.
Cable is sold in 1 foot increments. Specify desired length on purchase order.



Glenair offers a full range of high-performance wire and cable, designed and manufactured for optimal performance in mission-critical applications—with no dollar or length order minimums.

Mil-spec data transmission wire



Airframe non-impedance-matched data transmission cable for termination of AlphaLink SL solder-cup connectors

M22759/11 SILVER-COATED COPPER WIRE WITH EXTRUDED TFE INSULATION: GENERAL PURPOSE, HIGH-TEMPERATURE RANGE WIRE FOR USE WITH ALPHALINK SL 171-134-01

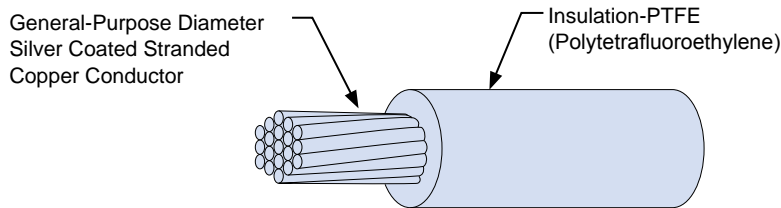
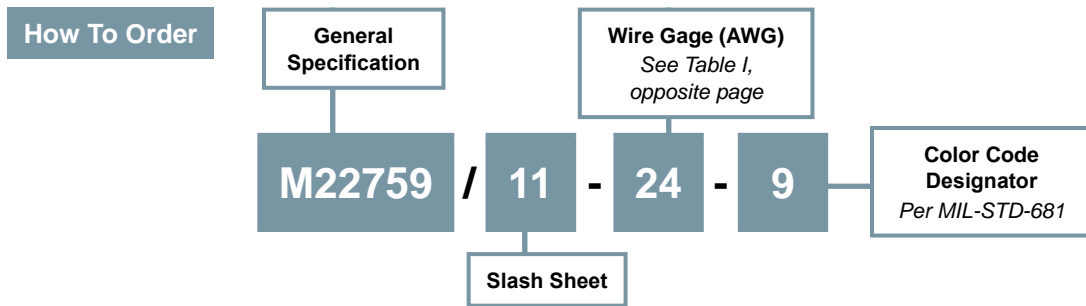

M22759/33 SILVER-COATED COPPER WIRE WITH CROSSLINKED, MODIFIED ETFE INSULATION: SMALL DIAMETER, HIGH-FLEX WIRE FOR USE WITH ALPHALINK SL 171-134-01

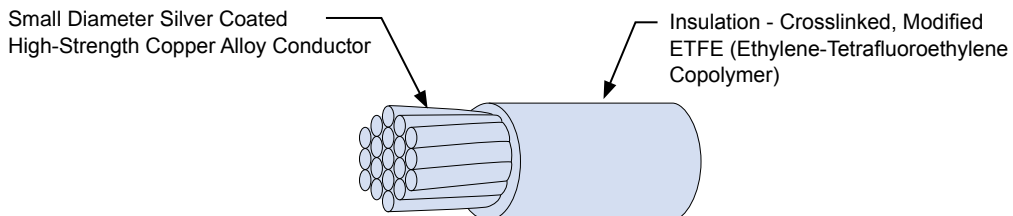
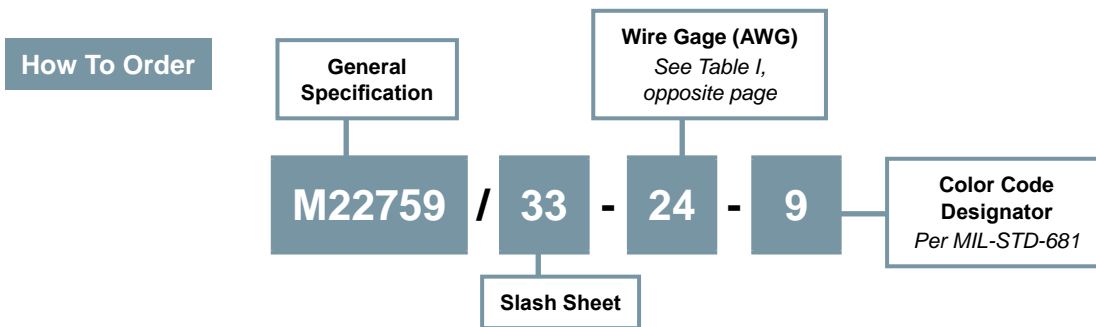



Custom micro and nanominiature flex solutions

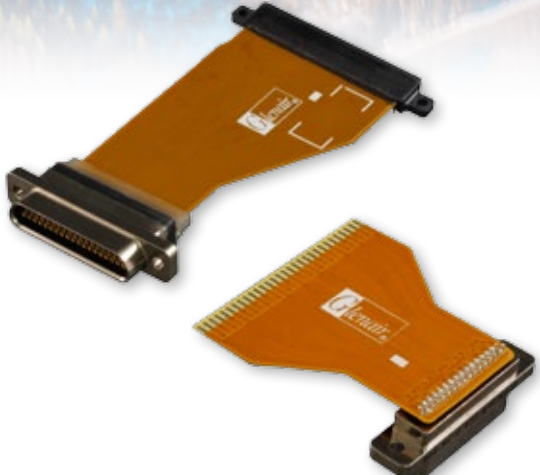

Build-to-print interconnect assemblies that combine circuit board technology and cabling into a lightweight, integrated package.

Glenair turnkey design, termination and assembly services available worldwide.



For more information contact Glenair at 818-247-6000 or visit our website at www.glenair.com

Flex circuit assemblies for mission-critical applications

Four reasons to specify flex in your next application

1 Unsurpassed Experience in Micro/Nano Flex Circuit Assembly

Glenair has been integrating Micro-D and Nanominiature connectors into flex circuitry for over 30 years. Our technical capabilities include design and layout of turnkey assemblies as well as the production of custom-configured micro and nano interconnects for maximum size and weight savings.

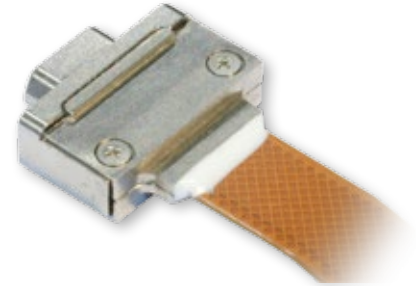
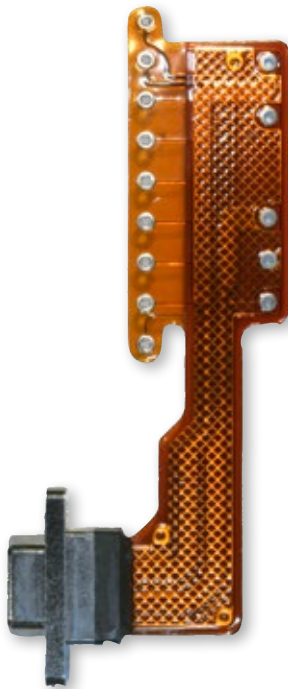

2 Full Spectrum Product Offering

Glenair offers a complete range of miniaturized printed circuit board connectors with high-reliability TwistPin contacts. We supply both through-hole and surface mount designs in every angle and mounting style for integration into single-sided, double-sided and multilayered flex circuitry.



3 Application Design

Our turnkey Micro-D and Nanominiature flex circuit assemblies are produced to exacting specifications.

Customer-supplied concepts and designs are reviewed and revised to ensure the most advantageous utilization of EMI shielding, polarization, strain-relief and connector packaging technologies. At Glenair, the final design solution is optimized to meet the exact mechanical and electronic requirements of the target environment.

4 Termination Expertise

Glenair's experienced workforce is trained and qualified to produce consistently reliable circuit terminations using the most advanced techniques and technologies, including automated solder reflow systems.



Lightweight and Versatile Flex Circuitry

Connector qualifications and design expertise help make Glenair the world's premier high-reliability flex circuitry termination/assembly facility

Flex circuitry combines ordinary printed circuit board technology and wiring into a single, integrated package. Glenair offers unsurpassed experience and expertise in flex circuit integration and termination for mission-critical applications. Our Mansfield, England and Glendale, California cable shops have been integrating Glenair manufactured connectors into flex circuitry for over 30 years. Our technical capabilities include valuable design and layout experience with custom rigid and multilayered flex assemblies and the ability to terminate the assemblies to Glenair's broad range of miniaturized rectangular and circular connectors, including qualified MIL-DTL-83513 and MIL-DTL-32139 products. The benefits of a Glenair produced "flexi" compared to discrete wiring solutions include:

Unsurpassed size and weight reduction

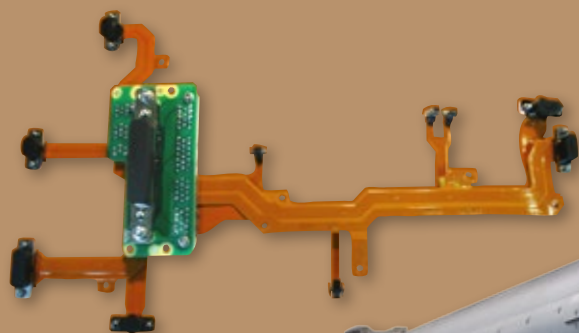

A single, integrated, multi-branch flex circuit assembly is orders of magnitude smaller and lighter than an equivalent ribbon cable or discrete wire harness. Well-conceived flex circuit designs can efficiently replace bulkier hard printed circuit boards, heavier

cable runs, and hard-to-manage loose

connectors and accessories. The ability to exactly shape the flex circuit to take advantage of the limited space in densely packaged electronic enclosures, such the seeker housing in an air-to-ground missile, results in unequalled size and

weight savings.



Outstanding mechanical performance

Flex circuitry is extremely durable and capable of withstanding high levels of vibration, shock, and other forms of mechanical stress. The custom nature of flex circuitry designs allows for the incorporation of stiffeners as well as localized bonding and termination to standard boards. Flex circuitry is by design extremely thin, flexible, lightweight and low mass, which directly reduces the impact on solder joints

and other physical points of contact within the equipment enclosure. Users of flex circuitry expect and receive extremely long duty cycles, vibration resistance, as well as long-term performance and high durability. The fixed shape of the flex circuit assembly delivers reliable and repeatable installation with proven resistance to vibration-related wear cycles—making flex circuitry ideally suited for use in aircraft avionics, and other electronic packages which are subject to severe physical stress.



Convenient packaging and integration

Flex circuit assemblies are ideally suited for space-constrained electronic packages and enclosures, or for interconnect systems that are required to flex in 3 axes during normal use. Flex circuitry offers complete design freedom to configure boards and wiring according to the unique packaging and space constraints of even the most densely-packed electronic enclosures. In mission-critical applications such as tactical command, control and communication technologies, the ability to reduce or even eliminate discrete wiring and boards in favor of hybrid flex circuitry helps designers make the most efficient use of available space.



Reliable resistance to Harsh environments

All forms of flex and rigid flex circuitry are encapsulated in polyimide materials that deliver outstanding protection of conductors. This unique dielectric material is ideally suited for interconnect applications that must perform in even the harshest application environments. The standards for resistance to temperature extremes, repetitive flex cycles, exposure to caustic chemicals, and UV radiation are defined in military specifications which include MIL-PRF-31032/3A and MIL-PRF-31032/4A. Other specifications adhered to by flex manufacturers used by Glenair include IPC standards that regulate base materials, dielectrics, adhesives and other key materials.

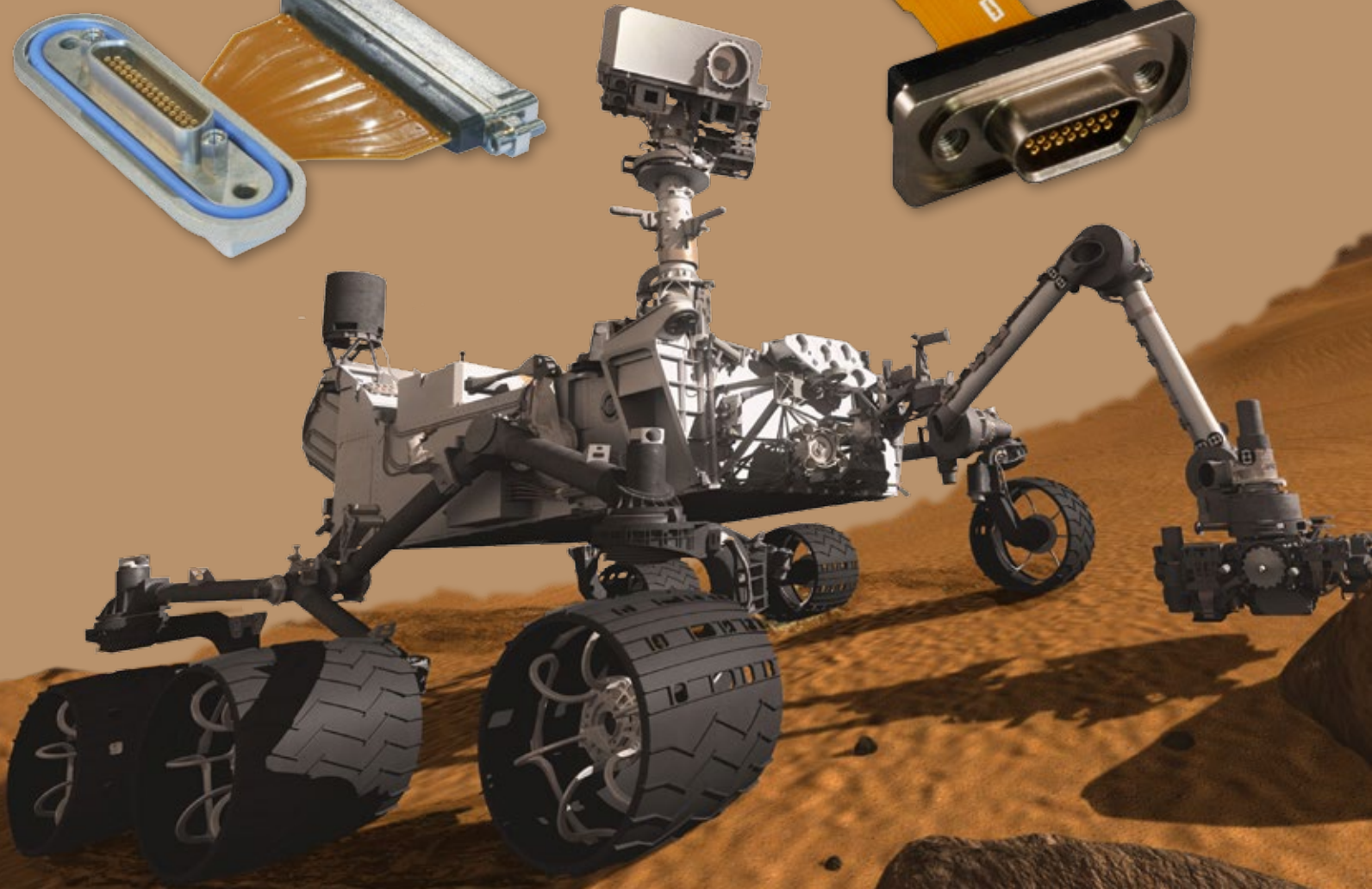

Why Choose **GLENAIR?**



Plenty of Raw Materials!



Outstanding
Customer Service!



Abundant Machining Capacity!



In-House Assembly!



Huge "Same-Day" Inventory!



One of North America's
and Machining



High-Production Injection Molding Equipment

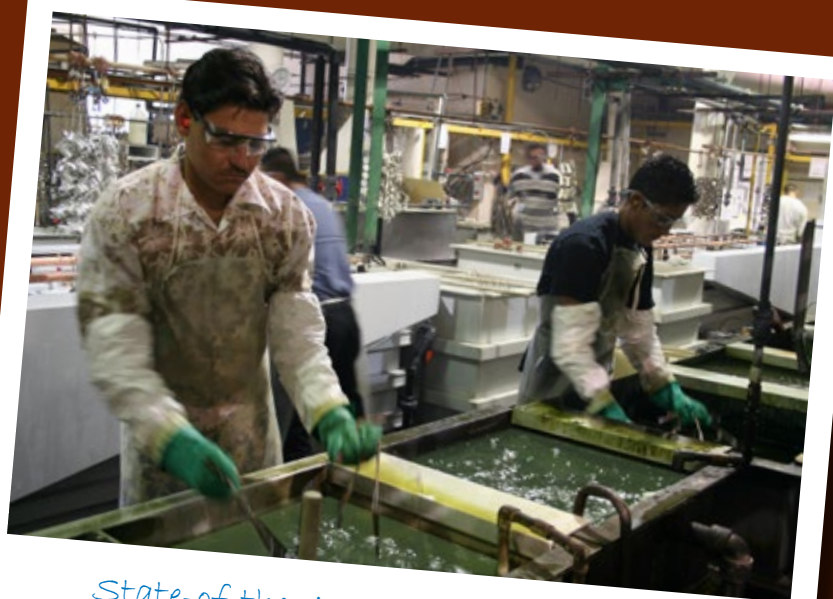

State-of-the-Art Plating Capabilities



The Industry's Most Experienced EMI/RFI Braided Shielding Specialists



Largest CNC Milling Installations



Clean Rooms for Filter Array and Printed Circuit Board Assembly



Out of This World
**INTERCONNECT
SOLUTIONS**

Glenair, Inc.

1211 Air Way • Glendale, California • 91201-2497
Telephone: 818-247-6000 • Fax: 818-500-9912 • sales@glenair.com
www.glenair.com

**Glenair Power
Products Group**

860 N. Main Street Extension
Wallingford, CT
06492

Telephone:
203-741-1115
Facsimile:
203-741-0053
sales@glenair.com

Glenair UK Ltd

40 Lower Oakham Way
Oakham Business Park
P.O. Box 37, Mansfield
Notts, NG18 5BY England

Telephone:
+44-1623-638100
Facsimile:
+44-1623-638111
sales@glenair.co.uk

Glenair Microway Systems

7000 North Lawndale Avenue
Lincolnwood, IL
60712

Telephone:
847-679-8833
Facsimile:
847-679-8849

Glenair Nordic AB

Gustav III : S Boulevard 46
S - 169 27 Solna
Sweden

Telephone:
+46-8-50550000
Facsimile:
+46-8-50550001
sales@glenair.se

Glenair Electric GmbH

Schaberweg 28
61348 Bad Homburg
Germany

Telephone:
06172 / 68 16 0
Facsimile:
06172 / 68 16 90
germany@glenair.com

Glenair Iberica

C/ La Vega, 16
45612 Velada
Spain

Telephone:
+34-925-89-29-88
Facsimile:
+34-925-89-29-87
sales@glenair.es

Glenair Italia S.p.A.

Via Del Lavoro, 7
40057 Quarto Inferiore –
Granarolo dell'Emilia
Bologna, Italy

Telephone:
+39-051-782811
Facsimile:
+39-051-782259
info@glenair.it

Glenair France SARL

7, Avenue Parmentier
Immeuble Central Parc #2
31200 Toulouse
France

Telephone:
+33-5-34-40-97-40
Facsimile:
+33-5-61-47-86-10
sales@glenair.fr

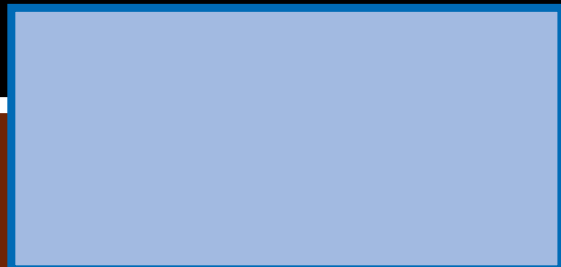

Компания «Life Electronics» занимается поставками электронных компонентов импортного и отечественного производства от производителей и со складов крупных дистрибьюторов Европы, Америки и Азии.

С конца 2013 года компания активно расширяет линейку поставок компонентов по направлению коаксиальный кабель, кварцевые генераторы и конденсаторы (керамические, пленочные, электролитические), за счёт заключения дистрибьюторских договоров

Мы предлагаем:

- Конкурентоспособные цены и скидки постоянным клиентам.
- Специальные условия для постоянных клиентов.
- Подбор аналогов.
- Поставку компонентов в любых объемах, удовлетворяющих вашим потребностям.
- Приемлемые сроки поставки, возможна ускоренная поставка.
- Доставку товара в любую точку России и стран СНГ.
- Комплексную поставку.
- Работу по проектам и поставку образцов.
- Формирование склада под заказчика.
- Сертификаты соответствия на поставляемую продукцию (по желанию клиента).
- Тестирование поставляемой продукции.
- Поставку компонентов, требующих военную и космическую приемку.
- Входной контроль качества.
- Наличие сертификата ISO.

В составе нашей компании организован Конструкторский отдел, призванный помогать разработчикам, и инженерам.

Конструкторский отдел помогает осуществить:

- Регистрацию проекта у производителя компонентов.
- Техническую поддержку проекта.
- Защиту от снятия компонента с производства.
- Оценку стоимости проекта по компонентам.
- Изготовление тестовой платы монтаж и пусконаладочные работы.



Тел: +7 (812) 336 43 04 (многоканальный)
Email: org@lifeelectronics.ru