

FUSB303EVBUM

FUSB303 Evaluation Board User's Manual



ON Semiconductor®

www.onsemi.com

EVAL BOARD USER'S MANUAL

Introduction

The FUSB303 evaluation board and included software allows customers a complete platform to evaluate the Type-C™ interface detection solution the FUSB303 provides. The evaluation board is designed for both stand-alone operation and connection to test equipment for specific testing requirements. With a single connection to a PC and using the FUSB303 GUI (Graphical User Interface), or with just a power supply, the evaluation board can be configured and function as a Source, Sink, or DRP device with Accessory detection support.

Description

The FUSB303 device is a fully autonomous USB Type-C™ controller optimized for 15W or less applications. The FUSB303 offers CC logic detection for Source Port role, Sink Port role, DRP Port role, and accessory detection support, as well as Dead Battery support as defined in USB-C specifications. The FUSB303 features configurable I²C address to support multiple ports per system or it can operate autonomously configured by just pins. The FUSB303 features ultra-low power during operation and an ultra-thin, 12 Lead QFN package.

Features

- Fully Autonomous USB Type-C™ Port Controller
- Supports USB Type-C™ Specification Release 1.2
- Source, Sink, and DRP Port role Configuration with Optional Accessory Support
- Try.SRC and Try.SNK modes for Preferring Source Role or Sink Role Respectively
- V_{DD} Operating Range: 2.7 V – 5.5 V
- Typical Low Power Operation: I_{CC} < 10 μA
- GPIO and I²C Configurable
- Dead Battery Support (Sink Port role when No Power Applied)
- 4 kV HBM ESD Protection for Connector Pins
- Small Packaging: 12 Lead QFN (1.6 mm x 1.6 mm x 0.375 mm)

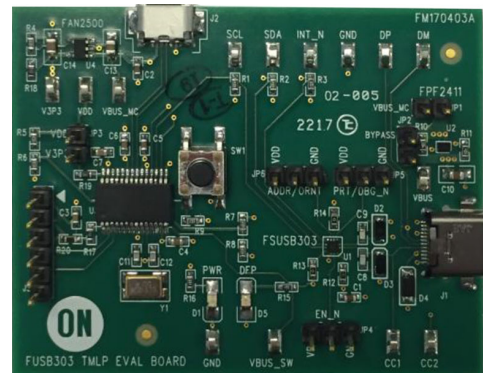

FUSB303EVBUM

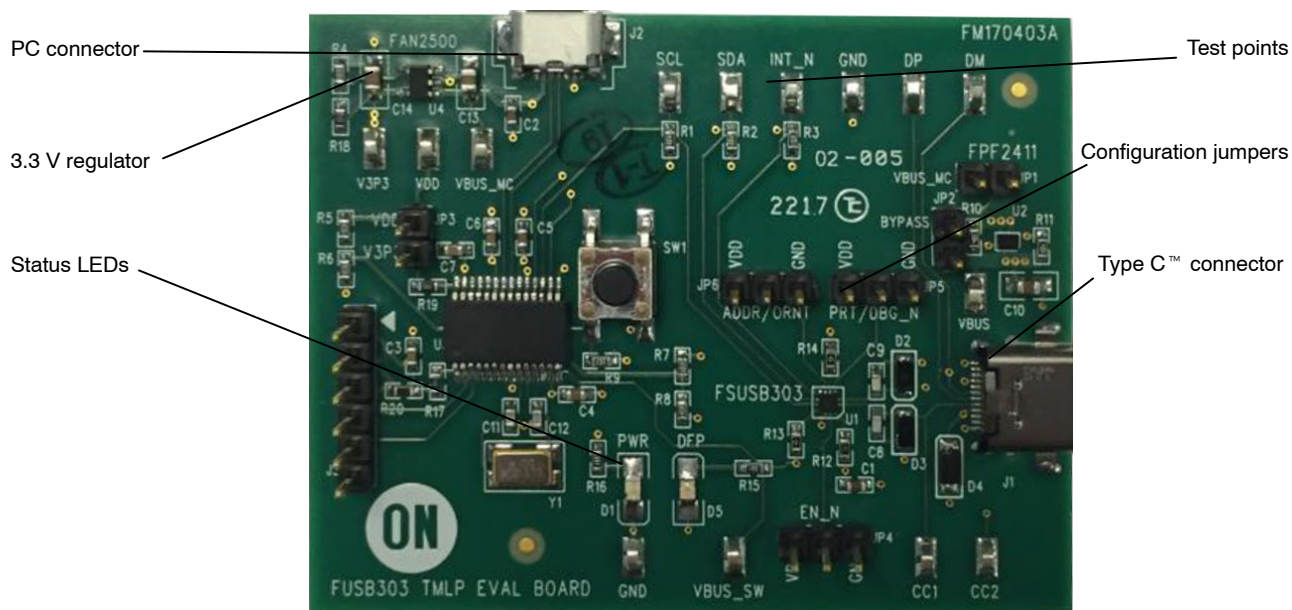

Figure 1. Evaluation Board Layout

APPLICATIONS INFORMATION

Power Configuration

The FUSB303 evaluation board is designed to be powered from just the PC connection or powered externally based on testing requirements.

Power Supplied From Board

The FUSB303 can fully operate from the VBUS input of the micro-B USB receptacle J2. To operate the evaluation board, the USB power should be provided to the board over the micro-B USB connector. Then, the on-board regulator generates VDD, which is 3.3V for the device supply. Once valid USB power is provided, the indicator LED, “PWR”, will be turned on.

I²C Communication

Communication with the FUSB303, when in I²C mode, is done through I²C accesses. The evaluation board allows for different ways of connecting I²C masters to the FUSB303.

Direct I²C Connection

Customers that want to directly control their I²C masters to the evaluation board can connect the I²C master signals to the SCL, SDA, and INT_N test points. The evaluation board has 10kΩ pull-ups to VDD, which is 3.3V, on each of these signals.

PC I²C Connection

The evaluation board uses a PIC32MX250F128 microcontroller as an I²C master to control the FUSB303 when it is configured as an I²C slave. This is the communication method used by the FUSB303 GUI. By connecting the PC to the micro-B USB receptacle, J2, the evaluation board automatically powers the microcontroller and connects the I²C master to the FUSB303.

Type-C™ Signal Connections

The FUSB303 evaluation board allows different ways of connecting to another Type-C™ device or controlling the signals of the Type-C™ receptacle based on the type of testing that is required.

CC Pins

The Type-C™ CC1 and CC2 pins are directly connected to the Type-C™ receptacle, J1, on the board. There is also a test point for each pin that can be used to connect the CC pins externally. Note that the FUSB303 evaluation board contains the minimum cReceiver capacitance specified in the USB PD specification for the CC pins which is 200pF. This capacitance is C8 and C9 in the schematic.

VBUS

VBUS is used differently based on the Type-C™ port type. As a device/UFP port, VBUS is directly connected to the Type-C™ receptacle, J1, and the VBUS test point located near J1. As a host/DFP port, VBUS can be supplied to the receptacle, J1, and controlled by the FUSB303 device. When connected to a PC, VBUS is supplied from the micro-B USB connection. The FUSB303 controls an on-board load switch, the FPF2411 or U2, for enabling of VBUS to the Type-C™ receptacle, J1.

VCONN

VCONN is not supplied nor managed on the evaluation board.

USB2.0 and SBU

The USB2.0 and SBU signals are left open in the Type-C™ connector and no connections on the board.

FUSB303EVBUM

Table 1. STATUS LEDS

LED ID	LED Name	Description
D1	PWR	VDD is supplied to FUSB303 and microcontroller
D5	DFP	FUSB303 is Source Port role

Table 2. CONFIGURATION JUMPERS

Jumper ID	Jumper Name	Description
JP1	VBUS_MC	Connects VBUS to PPF2411 load switch
JP2	BYPASS	Bypasses the PPF2411 load switch
JP3	VDD/V3P3	Connects V3P3 supply to VDD rail (for FUSB303 VDD, I ² C pull-ups, and GPIO pull-ups)
JP4 (Note 1)	EN_N	Configures FUSB303 EN_N Input when JP6 = HI or LO (I ² C mode) <ul style="list-style-type: none"> EN_N must be LO when JP6 = float (GPIO mode) Float or HI = FUSB303 disabled LO = FUSB303 enabled
JP5 (Note 1)	PRT/DBG_N	Configures the FUSB303 PORT/DEBUG_N input when JP6 = HI or LO (I ² C mode) <ul style="list-style-type: none"> PRT/DBG_N is ignored when JP6 = float (GPIO mode) Float = port type is DRP HI = port type is SRC only LO = port type is SNK only
JP6 (Note 1)	ADDR/ORNT	Configures the FUSB303 ADDR/ORIENT input when JP6 = HI or LO (I ² C mode) <ul style="list-style-type: none"> LO = I²C 7-bit address is 21h (42h >> 1) HI = I²C 7-bit address is 31h (62 >> 1) When JP6 = float (GPIO mode) GPIO mode; no I²C access

1. Refer to FUSB303 datasheet for more details on these signals

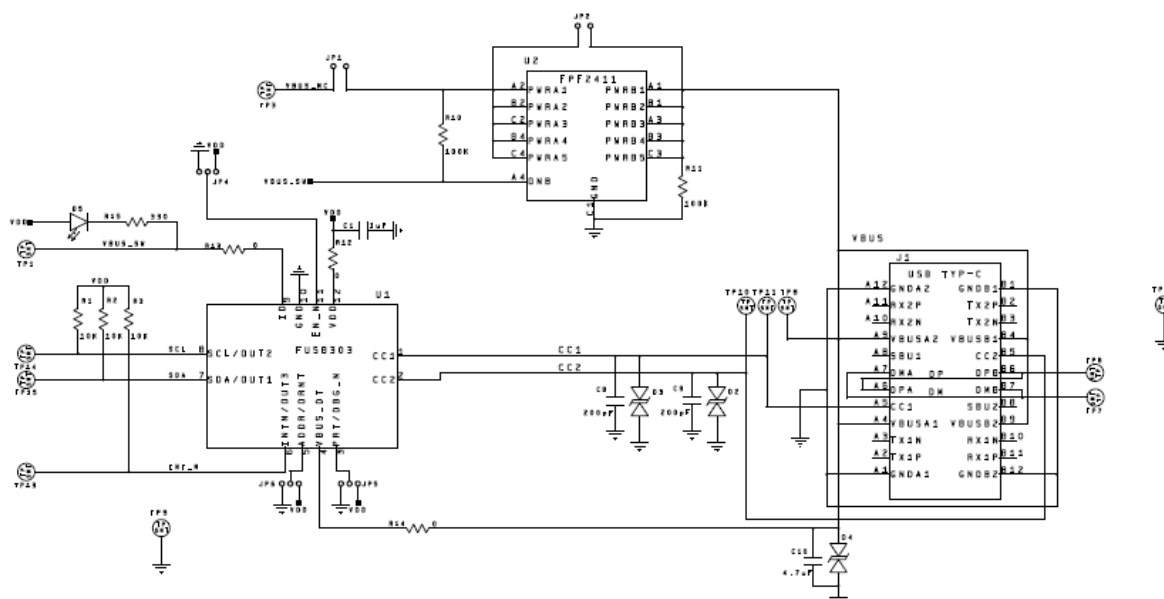

Figure 2. FUSB303 Evaluation Board FM170403A Schematic (1/2)

FUSB303EVBUM

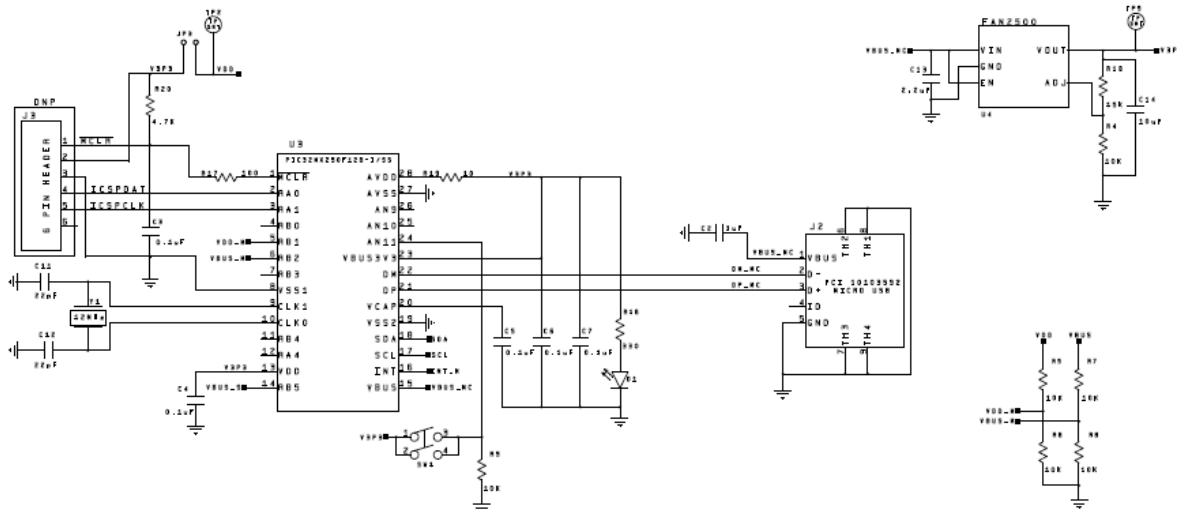

Figure 3. FUSB303 Evaluation Board FM170403A Schematic (2/2)

Figure 4. FUSB303 GUI Layout

GUI Installation

The FUSB303 GUI requires no special installation procedure. After requesting and receiving the download link for the GUI, download the archived GUI. Then extract the GUI file to an installation location on the PC.

GUI Startup

Double-click on the FUSB303 GUI executable to run the program. Plug the STD-A end of the USB cable into the

USB port of your PC. Plug the micro-B end of the USB cable into the GUI interface, J2, on the evaluation board. The “PWR” LED will illuminate if properly connected. Wait for the USB port to connect with a message in the lower left hand corner of the GUI that states “USB Device: VID: 0x0779 PID: 0x1118” highlighted in green. If the message background remains red and states “Disconnected”, then there is a connection problem.

FUSB303EVBUM

Automatic FUSB303 EVB I²C Address Detection

Before connecting the FUSB303 EVB to the GUI, the GUI will display a message in the lower right hand corner that states “No Device” highlighted in red. When the FUSB303 EVB is connected to the PC, the GUI will scan the FUSB303 EVB for its I²C address. Then the GUI will change the message in the lower right hand corner to state “Device Connected: v1.0.0” highlighted in green (possibly a different version number if the EVB firmware gets updated in the future). If the EVB is not detected, try clicking the “Scan I²C” button in the top, middle of the GUI (Figure 4) to see if this resolves the I²C address and connects.

GUI Dropdown Menus

- File
 - ◆ Click “Exit” to quit
- Preferences
 - ◆ Click “Auto Poll” to have the GUI constantly poll the FUSB302 EVB status
- Help
 - ◆ Click “About” to see the version of the GUI

FUSB303 EVB Status

When in “Auto Poll” mode, the FUSB303 GUI will constantly poll the FUSB303 EVB for various status and information. This information is displayed in the Type–C Status, Device ID, Status, and Interrupt sections across the top of the GUI.

General USB Tab

This tab allows you to read the current configuration of the FUSB303 with the Read Config button. It also allows you to change the configuration of the FUSB303 with the Write Config button. And the I²C Reset button allows you to reset the FUSB303 to its default configuration. Each section of the General tab correlates to a register of the FUSB303 and is described in the Register Definitions section of the FUSB303 datasheet.

Register Map Tab

This tab allows you to read or write any value to any register in the FUSB303. When performing a register write, the selected register/register is/are read back again to confirm the write action. So the write button actually performs a write then read function.

Script Tab

This tab enables the use of scripts to configure the FUSB303. Scripts can be added through the GUI using the editing window on the left of the tab. This edit window allows for normal copying and pasting to or from any text file if you want to save or copy your scripts from external files. Each line of the script should be formatted as follows:

Command, port, I²C addr, # bytes, register addr, data1, ..., dataN, optional comment

The *Command* is: “r” or “w”

The *port* is always 0

The *I²C addr* is either 0x42, 0x4A, 0x62, or 0x6A

The *# bytes* is the number of bytes to read or write

The *register addr* is the starting register address

The *data1* through *dataN* are for writing values to registers

And *optional comment* is just informational

Each field can be separated with a space (“ ”), a comma (“,”), or a semicolon (“;”).

An example of reading from 3 consecutive registers:

r 0 0x42 3 0x04 ; read 3 bytes starting at CONTROL (register address 0x04)

An example of writing to 2 consecutive registers:

w 0 0x42 2 0x0E 0x22 0x55 ; write 2 bytes starting at MASK (register address 0x0E)

The Execute button will run all the lines of the script.

The Step button will execute the highlighted line.

The Loop feature will loop the entire script up to 99 times. Setting Loop count to 0 will loop indefinitely.

Results of the executed script are shown in the box on the right side of the tab. These results can be copied and pasted to an external file.

Table 3. REVISION HISTORY

Rev.	Date	Description
1.0	October 2017	Initial release

ON Semiconductor and the ON Semiconductor logo are trademarks of Semiconductor Components Industries, LLC dba ON Semiconductor or its subsidiaries in the United States and/or other countries. ON Semiconductor owns the rights to a number of patents, trademarks, copyrights, trade secrets, and other intellectual property. A listing of ON Semiconductor's product/patent coverage may be accessed at www.onsemi.com/site/pdf/Patent-Marking.pdf. ON Semiconductor is an Equal Opportunity/Affirmative Action Employer. This literature is subject to all applicable copyright laws and is not for resale in any manner.

The evaluation board/kit (research and development board/kit) (hereinafter the "board") is not a finished product and is as such not available for sale to consumers. The board is only intended for research, development, demonstration and evaluation purposes and should as such only be used in laboratory/development areas by persons with an engineering/technical training and familiar with the risks associated with handling electrical/mechanical components, systems and subsystems. This person assumes full responsibility/liability for proper and safe handling. Any other use, resale or redistribution for any other purpose is strictly prohibited.

The board is delivered "AS IS" and without warranty of any kind including, but not limited to, that the board is production-worthy, that the functions contained in the board will meet your requirements, or that the operation of the board will be uninterrupted or error free. ON Semiconductor expressly disclaims all warranties, express, implied or otherwise, including without limitation, warranties of fitness for a particular purpose and non-infringement of intellectual property rights.

ON Semiconductor reserves the right to make changes without further notice to any board.

You are responsible for determining whether the board will be suitable for your intended use or application or will achieve your intended results. Prior to using or distributing any systems that have been evaluated, designed or tested using the board, you agree to test and validate your design to confirm the functionality for your application. Any technical, applications or design information or advice, quality characterization, reliability data or other services provided by ON Semiconductor shall not constitute any representation or warranty by ON Semiconductor, and no additional obligations or liabilities shall arise from ON Semiconductor having provided such information or services.

The boards are not designed, intended, or authorized for use in life support systems, or any FDA Class 3 medical devices or medical devices with a similar or equivalent classification in a foreign jurisdiction, or any devices intended for implantation in the human body. Should you purchase or use the board for any such unintended or unauthorized application, you shall indemnify and hold ON Semiconductor and its officers, employees, subsidiaries, affiliates, and distributors harmless against all claims, costs, damages, and expenses, and reasonable attorney fees arising out of, directly or indirectly, any claim of personal injury or death associated with such unintended or unauthorized use, even if such claim alleges that ON Semiconductor was negligent regarding the design or manufacture of the board.

This evaluation board/kit does not fall within the scope of the European Union directives regarding electromagnetic compatibility, restricted substances (RoHS), recycling (WEEE), FCC, CE or UL, and may not meet the technical requirements of these or other related directives.

FCC WARNING – This evaluation board/kit is intended for use for engineering development, demonstration, or evaluation purposes only and is not considered by ON Semiconductor to be a finished end product fit for general consumer use. It may generate, use, or radiate radio frequency energy and has not been tested for compliance with the limits of computing devices pursuant to part 15 of FCC rules, which are designed to provide reasonable protection against radio frequency interference. Operation of this equipment may cause interference with radio communications, in which case the user shall be responsible, at its expense, to take whatever measures may be required to correct this interference.

ON Semiconductor does not convey any license under its patent rights nor the rights of others.

LIMITATIONS OF LIABILITY: ON Semiconductor shall not be liable for any special, consequential, incidental, indirect or punitive damages, including, but not limited to the costs of requalification, delay, loss of profits or goodwill, arising out of or in connection with the board, even if ON Semiconductor is advised of the possibility of such damages. In no event shall ON Semiconductor's aggregate liability from any obligation arising out of or in connection with the board, under any theory of liability, exceed the purchase price paid for the board, if any.

For more information and documentation, please visit www.onsemi.com.

PUBLICATION ORDERING INFORMATION

LITERATURE FULFILLMENT:

Email Requests to: orderlit@onsemi.com

ON Semiconductor Website: www.onsemi.com

TECHNICAL SUPPORT

North American Technical Support:

Voice Mail: 1 800-282-9855 Toll Free USA/Canada

Phone: 011 421 33 790 2910

Europe, Middle East and Africa Technical Support:

Phone: 00421 33 790 2910

For additional information, please contact your local Sales Representative

Компания «Life Electronics» занимается поставками электронных компонентов импортного и отечественного производства от производителей и со складов крупных дистрибьюторов Европы, Америки и Азии.

С конца 2013 года компания активно расширяет линейку поставок компонентов по направлению коаксиальный кабель, кварцевые генераторы и конденсаторы (керамические, пленочные, электролитические), за счёт заключения дистрибьюторских договоров

Мы предлагаем:

- Конкурентоспособные цены и скидки постоянным клиентам.
- Специальные условия для постоянных клиентов.
- Подбор аналогов.
- Поставку компонентов в любых объемах, удовлетворяющих вашим потребностям.
- Приемлемые сроки поставки, возможна ускоренная поставка.
- Доставку товара в любую точку России и стран СНГ.
- Комплексную поставку.
- Работу по проектам и поставку образцов.
- Формирование склада под заказчика.
- Сертификаты соответствия на поставляемую продукцию (по желанию клиента).
- Тестирование поставляемой продукции.
- Поставку компонентов, требующих военную и космическую приемку.
- Входной контроль качества.
- Наличие сертификата ISO.

В составе нашей компании организован Конструкторский отдел, призванный помогать разработчикам, и инженерам.

Конструкторский отдел помогает осуществить:

- Регистрацию проекта у производителя компонентов.
- Техническую поддержку проекта.
- Защиту от снятия компонента с производства.
- Оценку стоимости проекта по компонентам.
- Изготовление тестовой платы монтаж и пусконаладочные работы.



Тел: +7 (812) 336 43 04 (многоканальный)

Email: org@lifeelectronics.ru