

PSR-MS20 / PSR-MS25

PL
EN ISO 13849

SILCL
IEC 62061

Safety relay for emergency stop and safety door monitoring



Data sheet
106167_en_03

© PHOENIX CONTACT 2015-08-21

1 Description

Intended Use

The **PSR-MS20** and **PSR-MS25** safety relays can be used to monitor single-channel signal generators, e.g., emergency stop buttons and safety door locking mechanisms, and to control actuators.

The safety relays are equipped with an enabling current path that drops out without delay according to stop category 0 in accordance with EN 60204-1.

In the case of the **PSR-MS20** safety relay, the enabling current path is controlled automatically once the sensor circuit has been closed.

In the case of the **PSR-MS25** safety relay, the enabling current path is controlled once the sensor circuit has been closed and the manual reset device (reset button) has first been pressed and released again (manual, monitored start).

With the manual, monitored reset device, a machine start may not be triggered in accordance with EN ISO 13849-1.

Features

- Safety relay for emergency stop and safety door monitoring
- Suitable up to category 1, PL c (EN ISO 13849-1), SILCL 1 (EN 62061)
- Depending on the application, suitable up to category 4, PL e (EN ISO 13849-1), SILCL 3 (EN 62061)
- 1 single-channel sensor circuit
- 1 undelayed enabling current path
- 1 digital signal output
- Fixed screw connection
- 6.8 mm housing width



WARNING: Risk of electric shock

Observe the safety instructions in the corresponding section!



Make sure you always use the latest documentation. It can be downloaded from the product at phoenixcontact.net/products.



This document meets the same requirements as the original operating instructions in terms of contents and is valid for all products listed in the "Ordering data" section.

2	Table of contents	
1	Description	1
2	Table of contents	2
3	Ordering data	3
4	Technical data	3
5	Safety notes.....	6
6	Basic circuit diagram	7
	6.1 Block diagram PSR-MS20	7
	6.2 Block diagram PSR-MS25	7
7	Derating.....	7
	7.1 Vertical or horizontal mounting position	7
8	Load curve.....	7
	8.1 Ohmic load	7
9	Function/time diagrams	8
	9.1 Time diagram PSR-MS20	8
	9.2 Time diagram PSR-MS25	8
10	Operating and indication elements	9
	10.1 Connection versions	9
	10.2 Connection assignment.....	9
11	Mounting and connection	10
12	Startup.....	10
13	Calculating the power dissipation	11
14	Diagnostics.....	12
	14.1 General states	12
	14.2 Error Messages.....	12
15	Application examples	13
	15.1 Emergency stop monitoring/automatic start.....	13
	15.2 Safety door monitoring/automatic start	13
	15.3 Connection to failsafe controller/automatic start	14
	15.4 Emergency stop monitoring/manual, monitored start	14
	15.5 Safety door monitoring/manual, monitored start.....	15
	15.6 Connection to failsafe controller/manual, monitored start	15
16	Revision history	16

3 Ordering data

Description	Type	Order No.	Pcs. / Pkt.
Safety relay for emergency stop and safety doors up to SIL 1, SILCL 1, Cat. 1, PL c, depending on the application up to SIL 3, SILCL 3, Cat. 4, PL e, 1-channel operation, automatic start, 1 enabling current path, $U_S = 24$ V DC, fixed screw terminal block	PSR-MS20-1NO-1DO-24DC-SC	2904950	1
Safety relay for emergency stop and safety doors up to SIL 1, SILCL 1, Cat. 1, PL c, depending on the application up to SIL 3, SILCL 3, Cat. 4, PL e, 1-channel operation, manual, monitored start, 1 enabling current path, $U_S = 24$ V DC, fixed screw terminal block	PSR-MS25-1NO-1DO-24DC-SC	2904951	1

4 Technical data

Hardware/firmware version	
HW/FW	≥ 00/-- (The technical data and safety characteristics are valid as of the specified HW/FW version.)
Input data	
Rated control supply voltage U_S	24 V DC -15 % / +10 %
Rated control supply current I_S	typ. 42 mA
Input voltage range "0"-signal	0 V DC ... 5 V DC (for safe off)
Typical inrush current	4.5 A ($\Delta t = 120 \mu s$ at U_S) < 20 mA (with U_S/I_x to S12) < 10 mA (with U_S/I_x at the start circuit)
Current consumption	< 5 mA (with U_S/I_x to S12) < 10 mA (with U_S/I_x at the start circuit)
Power consumption at U_S	typ. 1 W
Voltage at input/start and feedback circuit	24 V DC -15 % / +10 %
Filter time	1 ms (at A1 in the event of voltage dips at U_S) max. 1.5 ms (at S12; test pulse width) min. 7.5 ms (at S12; test pulse rate) Test pulse rate = 5 x Test pulse width
Max. permissible overall conductor resistance (Input and reset circuit at U_S)	150 Ω
Typical response time at U_S	< 175 ms
Typical starting time with U_S	< 250 ms (when controlled via A1)
Typical release time with U_S	< 20 ms (when controlled via A1 or S12)
Recovery time	< 500 ms
Maximum switching frequency	0.5 Hz
Operating voltage display	1 x green LED
Status display	2 x green LEDs
Protective circuit	Surge protection Suppressor diode Reverse polarity protection for rated control supply voltage
Output data	
Contact type	1 enabling current path
Contact material	AgSnO ₂
Minimum switching voltage	20 V AC/DC
Maximum switching voltage	250 V AC/DC
Limiting continuous current	6 A (N/O contact)
Maximum inrush current	6 A
Inrush current, minimum	3 mA
Sq. Total current	36 A ² (see to derating)

Output data

Switching capacity min.	60 mW
Mechanical service life	10 x 10 ⁶ cycles
Output fuse	6 A gL/gG (N/O contact) 4 A gL/gG (for low-demand applications)

Alarm outputs

Number of outputs	1 (digital, PNP)
Voltage	22 V DC (U _S - 2 V)
Current	max. 100 mA
Maximum inrush current	500 mA (Δt = 1 ms at U _S)
Short-circuit protection	no

General data

Relay type	Electromechanical relay with forcibly guided contacts in accordance with IEC/EN 61810-3 (EN 50205)
Nominal operating mode	100% operating factor
Degree of protection	IP20
Min. degree of protection of inst. location	IP54
Mounting type	DIN rail mounting
Mounting position	vertical or horizontal
Assembly instructions	See derating curve
Dimensions (W/H/D)	6.8 x 93.1 x 102.5 mm
Type of housing	PBT yellow
Clearances and creepage distances between the power circuits	DIN EN 50178
Rated insulation voltage	250 V AC
Rated surge voltage/insulation	Safe isolation, reinforced insulation 6 kV between input circuit and enabling current path Basic insulation 4 kV between all current paths and housing
Pollution degree	2
Surge voltage category	III

Connection data

Connection method	Screw connection
Conductor cross section, solid	0.2 mm ² ... 2.5 mm ²
Conductor cross section, stranded	0.2 mm ² ... 2.5 mm ²
Conductor cross section AWG/kcmil	26 ... 12
Stripping length	12 mm
Screw thread	M3

Ambient conditions

Ambient temperature (operation)	-40 °C ... 60 °C (observe derating)
Ambient temperature (storage/transport)	-40 °C ... 85 °C
Max. permissible relative humidity (operation)	75 % (on average, 85% infrequently, non-condensing)
Max. permissible humidity (storage/transport)	75 % (on average, 85% infrequently, non-condensing)
Maximum altitude	max. 2000 m (Above sea level)
Shock	15g
Vibration (operation)	10 Hz ... 150 Hz, 2g

Conformance / approvals

Conformance	CE-compliant
Approvals	

Safety data

Stop category according to IEC 60204	0
--------------------------------------	---

Safety parameters for IEC 61508 - High demand

SIL	1 (up to SIL 3 depending on the application)
PFH _d	1.5×10^{-9} (4 A DC13; 5 A AC15; 8760 switching cycles/year)
Demand rate	< 12 Months
Proof test interval	240 Months
Duration of use	240 Months

Safety parameters for IEC 61508 - Low demand

SIL	1 (up to SIL 3 depending on the application)
PFD _{avg}	1.47×10^{-4}
Proof test interval	60 Months
Duration of use	240 Months

Safety parameters for EN 62061

SIL CL	1 (up to SIL CL 3 depending on the application)
--------	---

Safety characteristic data according to EN ISO 13849

Category	1 (up to Cat. 4 depending on the application)
Performance level	c (up to PL e depending on the application)
Duration of use	240 Months
For applications in PL e, the required demand rate for the safety function is	once per month.
Calculation basis	4 A DC13; 5 A AC15; 8760 switching cycles/year

5 Safety notes



WARNING: Risk of electric shock

During operation, parts of electrical switching devices carry hazardous voltages.

Before working on the switching device, disconnect the power.

Please observe the safety regulations of electrical engineering and industrial safety and liability associations!

Disregarding these safety regulations may result in death, serious personal injury or damage to equipment.

Startup, mounting, modifications, and upgrades should only be carried out by a skilled electrical engineer!



WARNING: Risk of automatic machine restart!

For emergency stop applications, the machine must be prevented from restarting automatically by a higher-level control system.

Protective covers must not be removed when operating electrical switching devices.



WARNING: Danger due to faulty devices!

The devices may be damaged following an error and correct operation can no longer be ensured.

In the event of an error, replace the device immediately.

Repairs to the device, especially if the housing must be opened, may only be carried out by the manufacturer or authorized persons. Otherwise the warranty is invalidated.



WARNING: Risk due to incorrect installation

For reliable operation, the safety relay must be installed in housing protected from dust and humidity (IP54).

Carry out wiring according to the application. Refer to the "Application examples" section for this.



WARNING: Risk due to welded relay contacts

A suitable and effective protective circuit is to be provided for inductive loads. This is to be implemented parallel to the load and not parallel to the switch contact.



WARNING: danger due to magnetic interference!

Do not use the device in the vicinity of strong magnetic fields (e.g., caused by transformers or magnetic iron). The magnetic field strength of the environment must not exceed 30 A/m.



NOTE: Risk of damage to equipment due to noise emissions

When operating relay modules the operator must meet the requirements for noise emission for electrical and electronic equipment (EN 61000-6-4) on the contact side and, if required, take appropriate measures.



NOTE: Risk of damage to equipment due to noise emissions

This is a Class A product. In a domestic environment it may cause radion interference, in which case the user may be required to take adequate measures.



Only use power supply units with safe isolation and SELV / PELV in accordance with EN 50178/VDE 0160 (SELV / PELV).



NOTE: Electrostatic discharge!

The device contains components that can be damaged or destroyed by electrostatic discharge. When handling the device, observe the necessary safety precautions against electrostatic discharge (ESD) according to EN 61340-5-1 and EN 61340-5-2.

6 Basic circuit diagram

Key:

Designation	Explanation
A1	+24 V power supply
A2	0 V power supply
M1	Signal output (PNP)
S11	Output 24 V
S12	Input sensor circuit
S35 (PSR-MS20 only)	Automatic start
S34 (PSR-MS25 only)	Manual, monitored start
13/14	Enabling current path, undelayed

6.1 Block diagram PSR-MS20

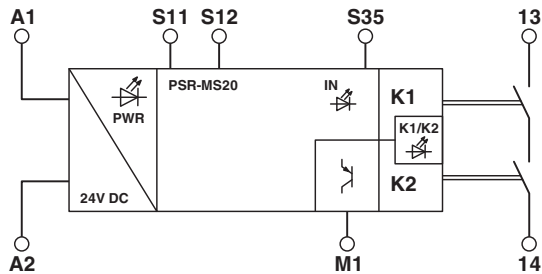

Figure 1 Block diagram PSR-MS20

6.2 Block diagram PSR-MS25

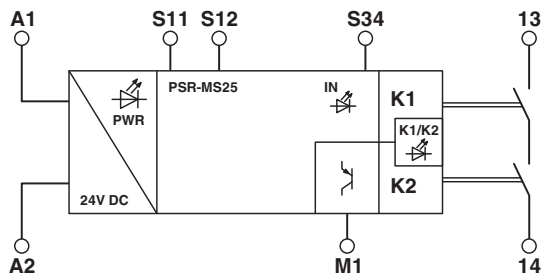

Figure 2 Block diagram PSR-MS25

7 Derating

7.1 Vertical or horizontal mounting position

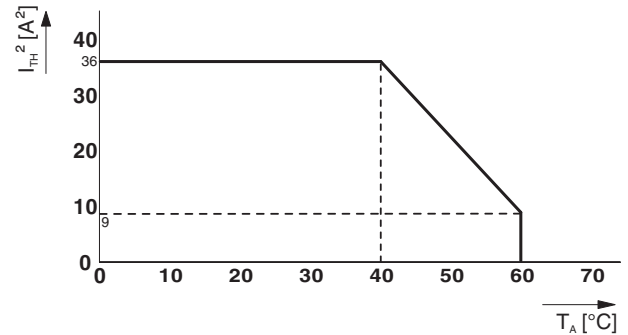

Figure 3 Derating curve - vertical or horizontal mounting position with connected modules

8 Load curve

8.1 Ohmic load

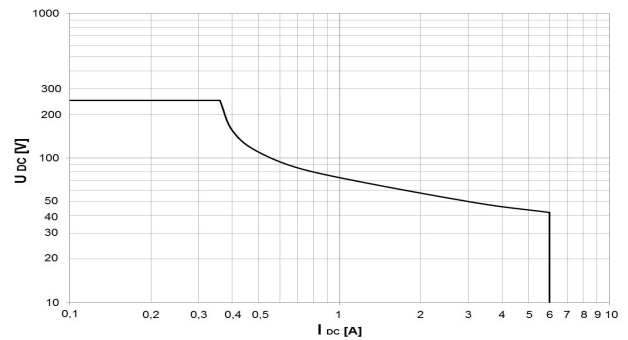

Figure 4 Relay load curve - ohmic load

9 Function/time diagrams

Key:

Designation	Explanation
A1/A2	Power supply
S35 (PSR-MS20 only)	Automatic start
S34 (PSR-MS25 only)	Manual, monitored start
S12	Input sensor circuit
13/14	Enabling current path, undelayed
M1	Signal output (PNP)

9.1 Time diagram PSR-MS20

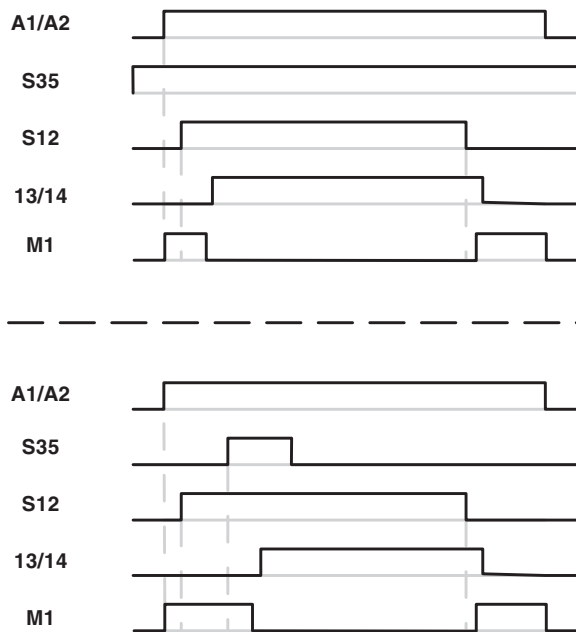

Figure 5 Time diagram PSR-MS20

9.2 Time diagram PSR-MS25

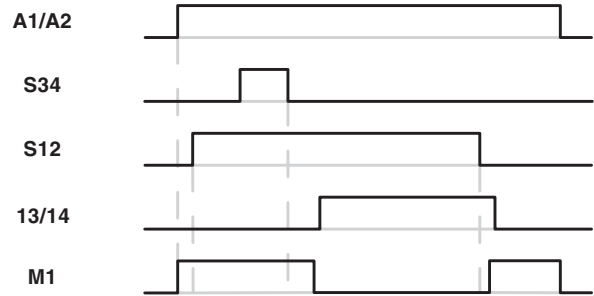

Figure 6 Time diagram PSR-MS25

10 Operating and indication elements

10.1 Connection versions

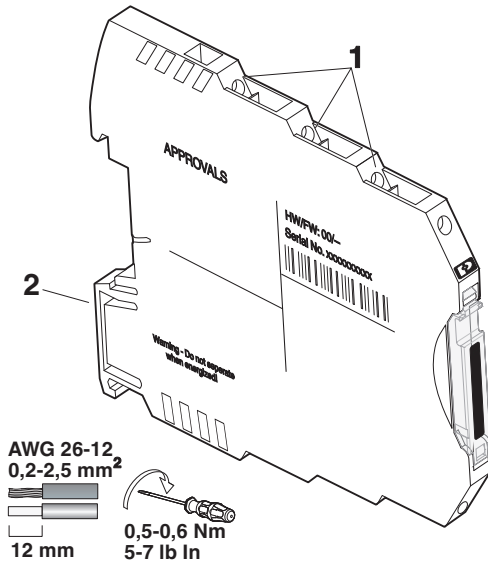

Figure 7 Connection versions

- 1 Fixed screw connection
- 2 Snap-on foot for DIN rail mounting



The year the device was constructed can be found underneath the CE designation on the housing.

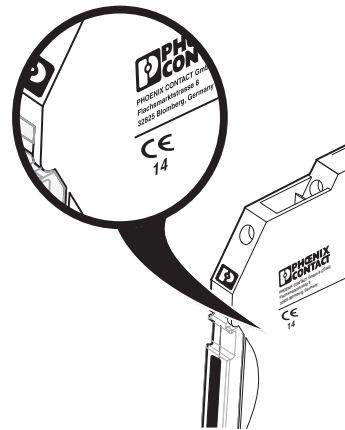

Figure 8 Year of manufacture of the device

10.2 Connection assignment

Figure	Designation	Explanation
	A 1	+24 V power supply
	A 2	0 V power supply
	S 11	Output 24 V
	S 12	Input sensor circuit
	PWR	Power LED (green)
	IN	Status indicator sensor circuit; LED (green)
	K1/K2	Status indicator safety circuit; LED (green)
	S 35 (PSR-MS20 only)	Automatic start
	S 34 (PSR-MS25 only)	Manual, monitored start
	1 4	Enabling current path, undelayed
	1 3	Enabling current path, undelayed
	M 1	Signal output (PNP)

11 Mounting and connection

Mount the module on a 35 mm DIN rail according to EN 60715.

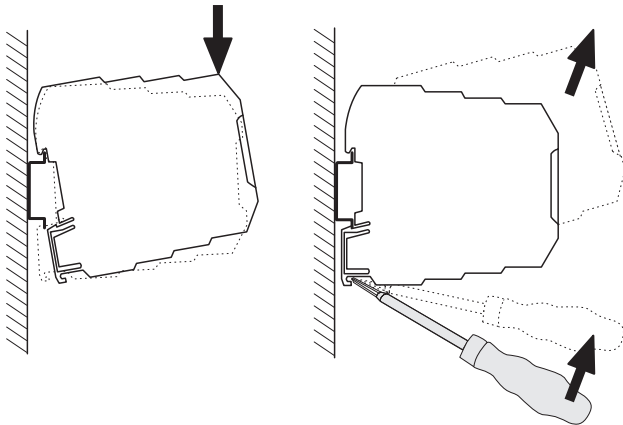

Figure 9 Mounting and removing

Connect the cables to the connection terminal blocks using a screwdriver.

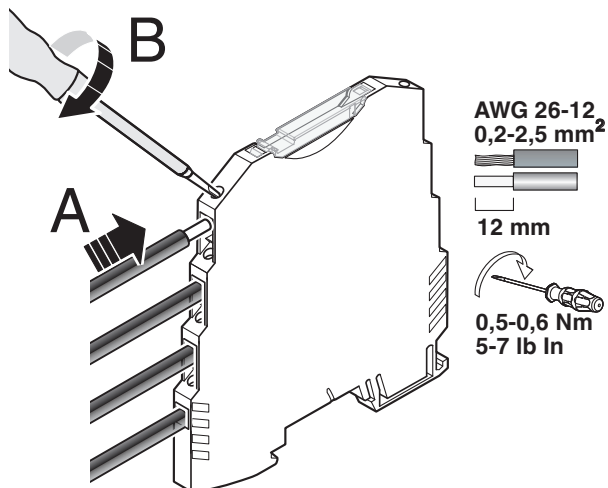

Figure 10 Connection of the cables



For compliance with UL approval, use copper wire that is approved up to 60°C/75°C.

12 Startup

Apply the rated control supply voltage (24 V DC) at terminal blocks A1/A2. The PWR LED lights up.

Close sensor circuit S11/S12. The IN LED lights up.

Automatic start (PSR-MS20 only):

Close contacts S11/S35. The enabling current path closes.

Manual, monitored start (PSR-MS25 only):

Close contacts S11/S34. When the start circuit is then opened, the enabling current path is closed.

The K1/K2 LED lights up.

When the rated control supply voltage drops or the sensor circuit (S11/S12) is opened, the enabling current path of the output circuit (13/14) opens and the contacts enter the safe state.

13 Calculating the power dissipation



The total power dissipation of the safety relay is based on the input power dissipation and the contact power dissipation for the same and for different load currents.

Input power dissipation

$$P_{\text{Input}} = U_B^2 / (U_S / I_S)$$

Contact power dissipation

With the same load currents:

$$P_{\text{Contact}} = n \cdot I_L^2 \cdot 50 \text{ m}\Omega$$

With different load currents:

$$P_{\text{Contact}} = (I_{L1}^2 + I_{L2}^2 + \dots + I_{Ln}^2) \cdot 50 \text{ m}\Omega$$

Total power dissipation

$$P_{\text{Total}} = P_{\text{Input}} + P_{\text{Contact}}$$

therefore

$$P_{\text{Total}} = U_B^2 / (U_S / I_S) + n \cdot I_L^2 \cdot 50 \text{ m}\Omega$$

or

$$P_{\text{Total}} = U_B^2 / (U_S / I_S) + (I_{L1}^2 + I_{L2}^2 + \dots + I_{Ln}^2) \cdot 50 \text{ m}\Omega$$

Key:

Designation	Explanation
P	Power dissipation in mW
U_B	Applied operating voltage
U_S	Rated control supply voltage
I_S	Rated control supply current
n	Number of enabling current paths used
I_L	Contact load current

14 Diagnostics

The following section describes the LED indicators for general states and error messages as well as possible causes and remedies.

Function test/proof test



Use the function test to check the safety function. To do this, request the safety function once by pressing the emergency stop button, for example. Check whether the safety function is running correctly by switching the device on again via the sensor circuits.

14.1 General states

PWR LED	IN LED	K1/K2 LED	State	Notes
ON	OFF	OFF	All relays are not activated. The sensor circuit is off.	Possible error see error messages
ON	ON	OFF	The sensor circuit is active. Relays K1 and K2 are ready to start and await reset/start command (S34 or S35).	-
ON	ON	ON	The sensor circuit is active. All relays are picked up.	-

14.2 Error Messages

PWR LED	IN LED	K1/K2 LED	State	Possible cause	Remedy
ON	OFF	OFF	The sensor circuit is actively controlled, but no input LEDs are lit up.	Interrupt in the sensor circuit or faulty signal generator.	Check the sensor circuit/signal generator. Then perform a function test.
ON	ON	OFF	The sensor circuit is active. The reset/start circuit (S34 or S35) is/was activated. The safety circuit (K1 and K2) is not picking up.	External error: the readback contact (external actuator) is open in the reset circuit. Internal error: 1. The diagnostic contact is not working correctly. 2. An N/O contact is welded.	External error: check the actuator. Internal error: perform a power down reset with subsequent function test. If the error occurs again after the function test, replace the device.
ON	ON	OFF	The sensor circuit is active. The reset/start circuit (S34) is/was activated. The safety circuit (K1 and K2) is not picking up.	Error during manual reset S34 (stuck-at at the input).	Remove the error in the reset/start circuit. Then perform a function test.
OFF	OFF	OFF	The sensor circuit is active.	1. No supply voltage at A1/A 2. Over- or undervoltage at A1	Check the supply voltage.

15 Application examples

Key:

- S1 = Emergency stop button
- S2 = Manual reset device
- B1 = Mechanical safety door switch
- K1/K2 = Contactors

Applications with the PSR-MS20

15.1 Emergency stop monitoring/automatic start

- Single-channel emergency stop monitoring
- Automatic start
- Monitoring of external contactors
- Suitable up to category 1, PL c (EN ISO 13849-1), SIL 1 (EN 62061)

i Contactor K2 is not essential in order to achieve category 1.

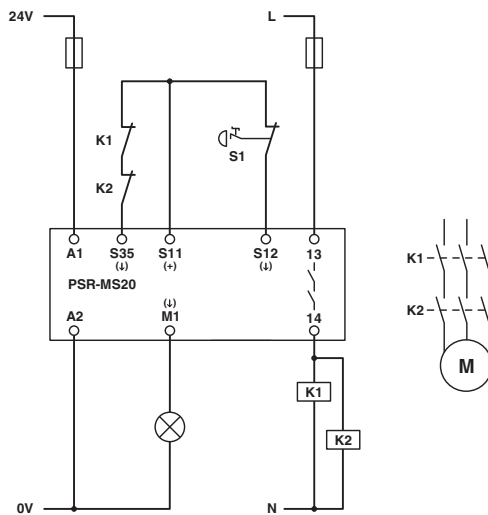

Figure 11 Emergency stop monitoring/automatic start

15.2 Safety door monitoring/automatic start

- Single-channel safety door monitoring
- Automatic start
- Monitoring of external contactors
- Suitable up to category 1, PL c (EN ISO 13849-1), SIL 1 (EN 62061)

i Contactor K2 is not essential in order to achieve category 1.

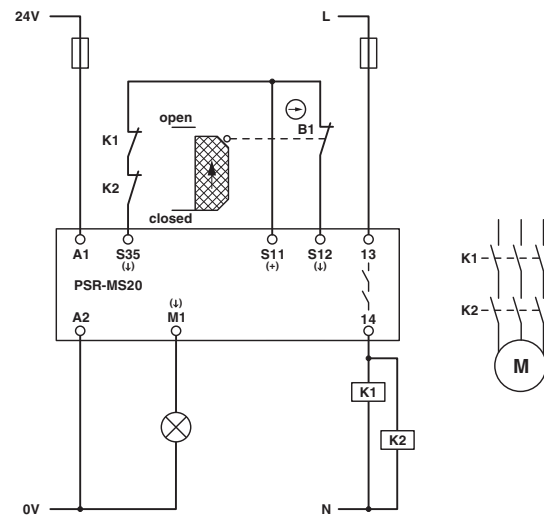

Figure 12 Safety door monitoring/automatic start

15.3 Connection to failsafe controller/automatic start

- Automatic start
- Monitoring of external contactors
- Suitable up to category 4, PL e (EN ISO 13849-1), SIL 3 (EN 62061) if the digital output of the safety-related controller meets PL e, SIL 3 and cross-circuits can be ruled out



WARNING: Loss of functional safety!
Make sure that the signal generator (e.g., PLC output card or light grid) and the safety relay have the same ground potential.



Cross-circuits in the cable installation can be excluded if the failsafe PLC, safety relay, and external contactors K1 and K2 are located in the same electrical installation space.

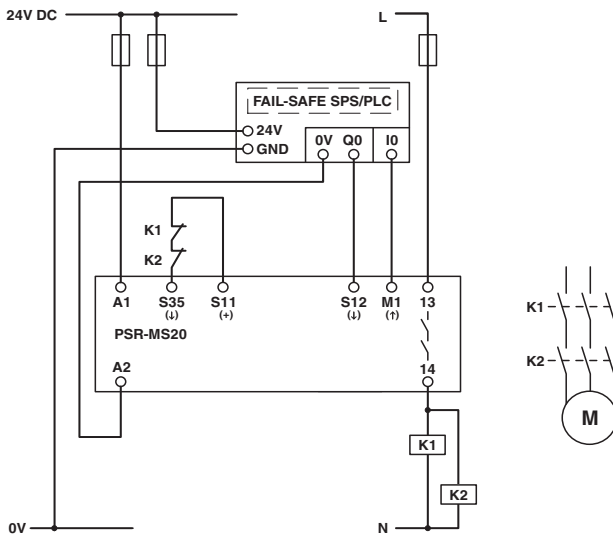

Figure 13 Connection to error-free PLC/automatic start

Applications with the PSR-MS25

15.4 Emergency stop monitoring/manual, monitored start

- Single-channel emergency stop monitoring
- Manual, monitored start
- Monitoring of external contactors
- Suitable up to category 1, PL c (EN ISO 13849-1), SIL 1 (EN 62061)



Contactors K2 is not essential in order to achieve category 1.

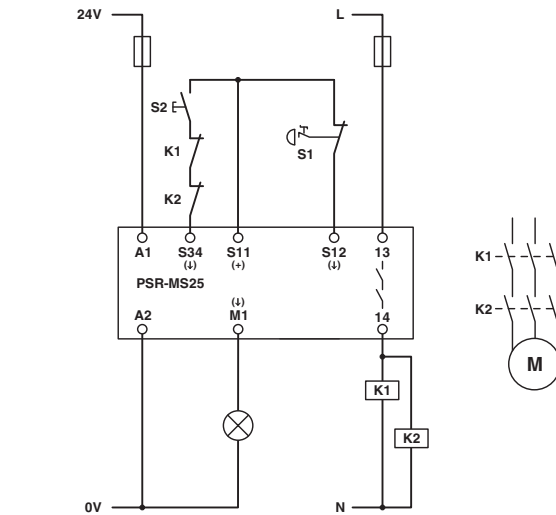

Figure 14 Emergency stop monitoring/manual, monitored start

15.5 Safety door monitoring/manual, monitored start

- Single-channel safety door monitoring
- Manual, monitored start
- Monitoring of external contactors
- Suitable up to category 1, PL c (EN ISO 13849-1), SIL 1 (EN 62061)



Contactor K2 is not essential in order to achieve category 1.

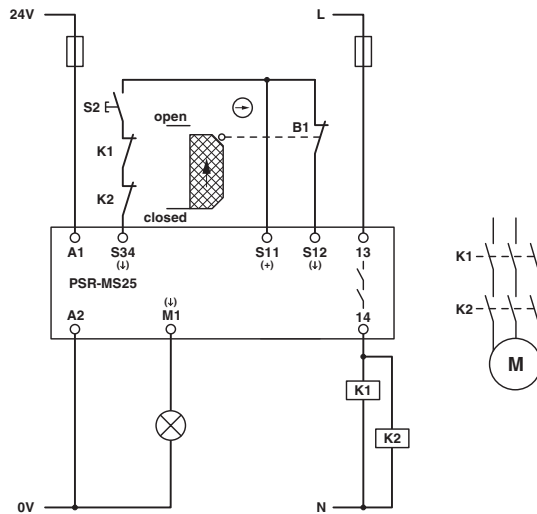

Figure 15 Safety door monitoring/manual, monitored start

15.6 Connection to failsafe controller/manual, monitored start

- Manual, monitored start
- Monitoring of external contactors
- Suitable up to category 4, PL e (EN ISO 13849-1), SIL 3 (EN 62061) if the digital output of the safety-related controller meets PL e, SIL 3 and cross-circuits can be ruled out



WARNING: Loss of functional safety!

Make sure that the signal generator (e.g., PLC output card or light grid) and the safety relay have the same ground potential.



Cross-circuits in the cable installation can be excluded if the failsafe PLC, safety relay, and external contactors K1 and K2 are located in the same electrical installation space.

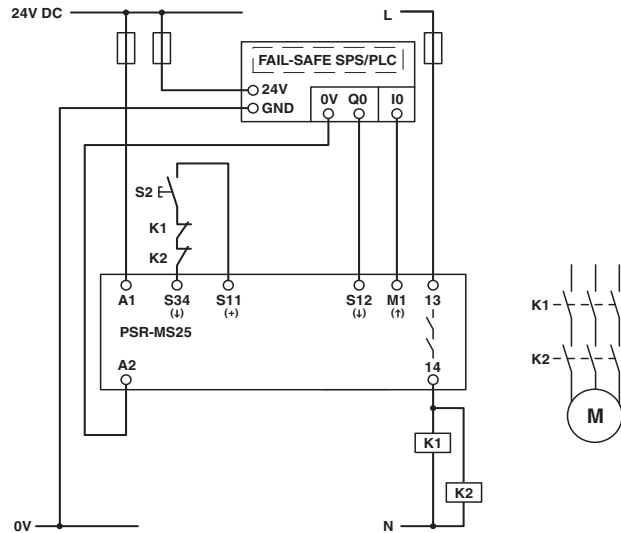

Figure 16 Connection to error-free PLC/manual, monitored start

16 Revision history

Version	Date	Contents
00	2014-12-03	First publication
01	2015-03-05	Reverse polarity protection extended; relay type extended; dimensions updated; load curve extended
02	2015-04-09	Cat., PL, SIL, SILCL revised in technical data
03	2015-08-21	Input voltage range "0"-signal added; relay type changed; application examples and notes for the examples revised

Компания «Life Electronics» занимается поставками электронных компонентов импортного и отечественного производства от производителей и со складов крупных дистрибьюторов Европы, Америки и Азии.

С конца 2013 года компания активно расширяет линейку поставок компонентов по направлению коаксиальный кабель, кварцевые генераторы и конденсаторы (керамические, пленочные, электролитические), за счёт заключения дистрибьюторских договоров

Мы предлагаем:

- Конкурентоспособные цены и скидки постоянным клиентам.
- Специальные условия для постоянных клиентов.
- Подбор аналогов.
- Поставку компонентов в любых объемах, удовлетворяющих вашим потребностям.
- Приемлемые сроки поставки, возможна ускоренная поставка.
- Доставку товара в любую точку России и стран СНГ.
- Комплексную поставку.
- Работу по проектам и поставку образцов.
- Формирование склада под заказчика.
- Сертификаты соответствия на поставляемую продукцию (по желанию клиента).
- Тестирование поставляемой продукции.
- Поставку компонентов, требующих военную и космическую приемку.
- Входной контроль качества.
- Наличие сертификата ISO.

В составе нашей компании организован Конструкторский отдел, призванный помогать разработчикам, и инженерам.

Конструкторский отдел помогает осуществить:

- Регистрацию проекта у производителя компонентов.
- Техническую поддержку проекта.
- Защиту от снятия компонента с производства.
- Оценку стоимости проекта по компонентам.
- Изготовление тестовой платы монтаж и пусконаладочные работы.



Тел: +7 (812) 336 43 04 (многоканальный)

Email: org@lifeelectronics.ru