

QorIQ LS Processor Family

QorIQ LS1012A Reference Design Board

The QorIQ LS1012A Reference Design Board is a compact form factor tool that enables evaluation and software development for a broad range of applications.

OVERVIEW

The QorIQ LS1012A communications processor addresses a wide variety of applications such as consumer NAS, battery-powered mobile NAS, entry-level broadband gateway, value-tier IoT gateways, trusted gateways, Industrial automation, building control, networked audio, Ethernet drives and more. The QorIQ LS1012A reference design board (LS1012ARDB) is a compact form-factor tool that enables evaluation of the LS1012A solution for these and other low-end networking applications. The LS1012ARDB also features an expansion connector suitable for adding additional components such as Arduino® shields.

The QorIQ LS1012ARDB can help shorten your time-to-market by exercising most capabilities of the device and can serve as a reference for hardware development. It can also be used as a debug tool to check behaviors on the board compared to behaviors seen on customer boards. The board can be used for software development and performance evaluation prior to the customer's own board being ready.

The LS1012ARDB comes in a compact 5.59 in x 5.59 in form factor which allows mounting in an enclosure. An SDIO Wi-Fi® module is included to facilitate evaluation and development of Wi-Fi connectivity solutions.

The LS1012A processor is a cost-effective, power-efficient and highly integrated system-on-chip design that extends the reach of NXP's Value Performance line of QorIQ communications processors into the ultra-value tier. Featuring an extremely power-efficient 64-bit ARM® Cortex®-A53 core running at up to 800 MHz and yielding over 2,000 CoreMarks, the LS1012A will deliver high packet processing performance and low power consumption.

Additional functionality includes an integrated hardware packet acceleration engine, together with high-speed interfaces and support for DDR3L running at 1000 MHz. High-speed peripherals include PCIe® Gen2, Super Speed USB3.0, USB2.0, SATA3.0 and dual Gigabit Ethernet controllers, with support for RGMII, and SGMII that can accommodate 2.5 Gbit Ethernet PHYs. To deliver outstanding security performance, the LS1012A features a hardware-based acceleration engine to support Secure Boot, and networking with both ARM® TrustZone™ and NXP's QorIQ Trust Architecture.



FEATURES

MEMORY

- ▶ 1GB DDR3L SDRAM
- ▶ 4 GB eMMC Memory
- ▶ SDHC Card Slot
- ▶ 128 MB QSPI NOR Flash
 - Bank0—64MB
 - Bank1—64MB

ETHERNET

- ▶ 2 x GbE LAN connectors
- ▶ 1 x PoE enable port

USB

- ▶ 1 x USB 3.0 micro AB port

OTHER

- ▶ 1 x SDIO Wi-Fi® module 2.4 GHz 802.11b/g/n
- ▶ 1 x half-height Mini PCI Express connector
- ▶ 1 x USB to JTAG using NXP's K22
- ▶ 1 x SATA connector
- ▶ 1 x 3-Axis digital angular rate gyroscope
- ▶ 1 x 6-axis sensor
- ▶ 1 x Arduino® shield header for expansion

QorIQ LS1012ARB SYSTEM BLOCK DIAGRAM

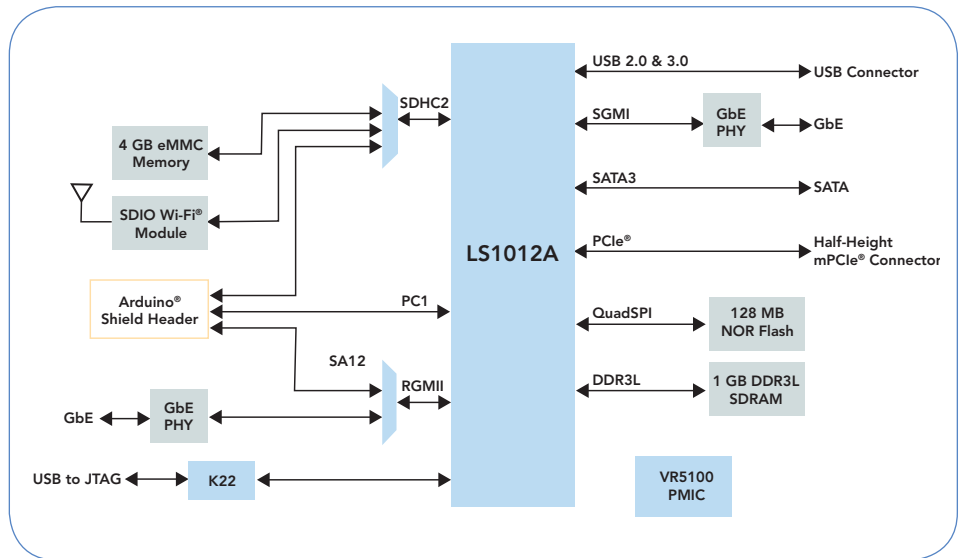

NXP DEVICES ON BOARD:

- ▶ LS1012A communications processor
- ▶ VR5100 multi-output DC-DC regulator
- ▶ K22 OpenSDA serial and debugger adapter
- ▶ FXAS21002 3-Axis digital angular rate gyroscope
- ▶ FXOS8700CQ 6-axis sensor with accelerometer and magnetometer
- ▶ BC3770 2.0 A switch-mode charger
- ▶ NTSX2102 dual-supply translating transceiver
- ▶ 74CBTLV3253 Dual 1 of 4 multiplexer/demultiplexer
- ▶ NX5P2190 logic-controlled high-side power switch
- ▶ CBTLO2043A 2:1 multiplexer/demultiplexer
- ▶ MC34713 5.0 A 1.0 MHz single switch-mode power supply

QorIQ LS1012A DEVELOPMENT BOARD

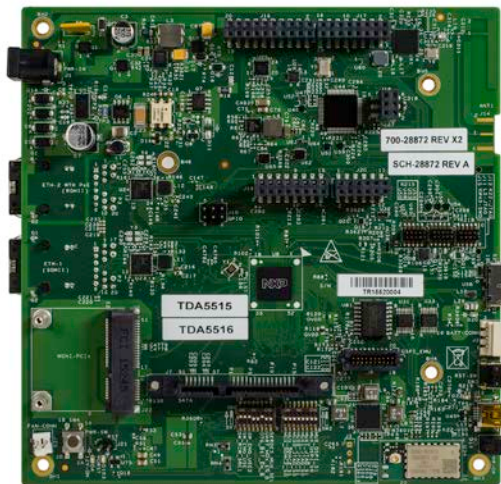
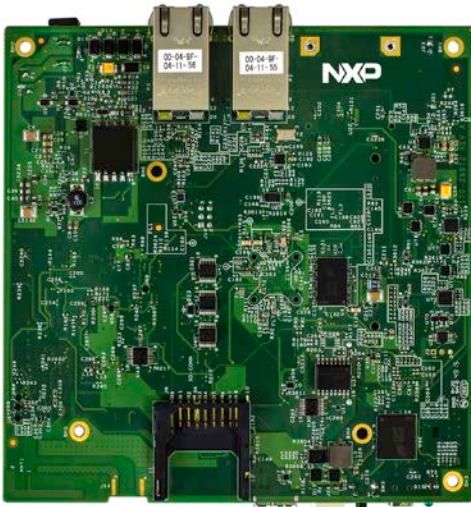

www.nxp.com

NXP, the NXP logo, Layerscape and QorIQNXP, the NXP logo, Layerscape and QorIQ are trademarks of NXP B.V. ARM, Cortex and TrustZone are registered trademarks of ARM Limited (or its subsidiaries) in the EU and/or elsewhere. All rights reserved. © 2014, 2016 NXP B.V.

Компания «Life Electronics» занимается поставками электронных компонентов импортного и отечественного производства от производителей и со складов крупных дистрибьюторов Европы, Америки и Азии.

С конца 2013 года компания активно расширяет линейку поставок компонентов по направлению коаксиальный кабель, кварцевые генераторы и конденсаторы (керамические, пленочные, электролитические), за счёт заключения дистрибьюторских договоров

Мы предлагаем:

- Конкурентоспособные цены и скидки постоянным клиентам.
- Специальные условия для постоянных клиентов.
- Подбор аналогов.
- Поставку компонентов в любых объемах, удовлетворяющих вашим потребностям.
- Приемлемые сроки поставки, возможна ускоренная поставка.
- Доставку товара в любую точку России и стран СНГ.
- Комплексную поставку.
- Работу по проектам и поставку образцов.
- Формирование склада под заказчика.
- Сертификаты соответствия на поставляемую продукцию (по желанию клиента).
- Тестирование поставляемой продукции.
- Поставку компонентов, требующих военную и космическую приемку.
- Входной контроль качества.
- Наличие сертификата ISO.

В составе нашей компании организован Конструкторский отдел, призванный помогать разработчикам, и инженерам.

Конструкторский отдел помогает осуществить:

- Регистрацию проекта у производителя компонентов.
- Техническую поддержку проекта.
- Защиту от снятия компонента с производства.
- Оценку стоимости проекта по компонентам.
- Изготовление тестовой платы монтаж и пусконаладочные работы.



Тел: +7 (812) 336 43 04 (многоканальный)

Email: org@lifeelectronics.ru

www.lifeelectronics.ru