

Tilt Sensor Switch

Item No.	RBS350100T	Description	Ball-Contact	Version	11
Page	1 of 15		Publish Date	Jul. 03, 2018	

● FUNCTIONS

Rotation Detecting for 4 directions in vertical mode

● APPLICATIONS

1. Screen rotation for portable 3C products

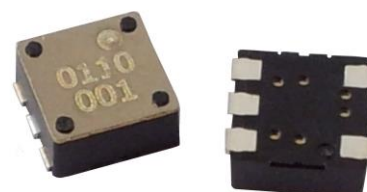

● FEATURES

1. Housing made of high insulation plastic material, free from electric conduction and rust problem.
2. Detecting with photo transistors, not affected by metal oxidization or wear. Possesses highly reliable and stable signals.
3. All plastic materials subject to industrial purpose, resist high temperature and meet fireproof function.
4. Simple ON and OFF signals, easy for design.
5. Suitable to vertical PCB.
6. RoHS compliance, an ideal substitute for mercury switch.
7. A more economical tilt and rotation detection option than IC design solution.
8. All made in Taiwan and examined before shipment.

● PATENTS

1. Taiwan Patent No. M 397113
2. Taiwan Patent No. I 441221
3. China Patent No. ZL 201020272893.2
4. Japan Patent No. 5281060
5. U.S.A. Patent No. US 8,586,910 B2



Tilt Sensor Switch

Item No.	RBS350100T	Description	Ball-Contact	Version	11
Page	2 of 15		Publish Date	Jul. 03, 2018	

● DIMENSIONS / P.C.B. LAYOUT (Unit: mm, Tolerance: ±0.20mm)

Fig. 1

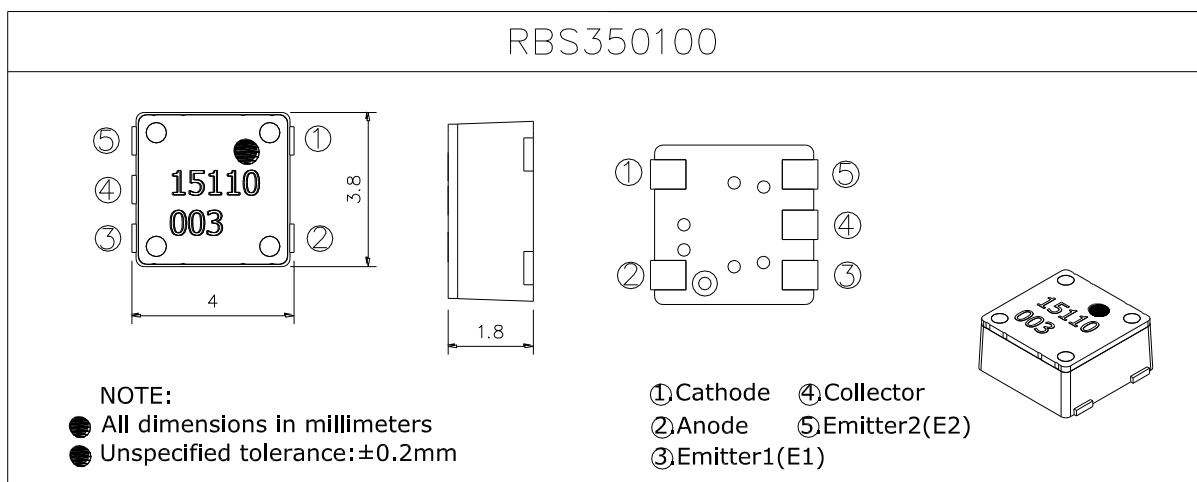

● PACKING ICON OF TAPE & REEL

Fig. 2

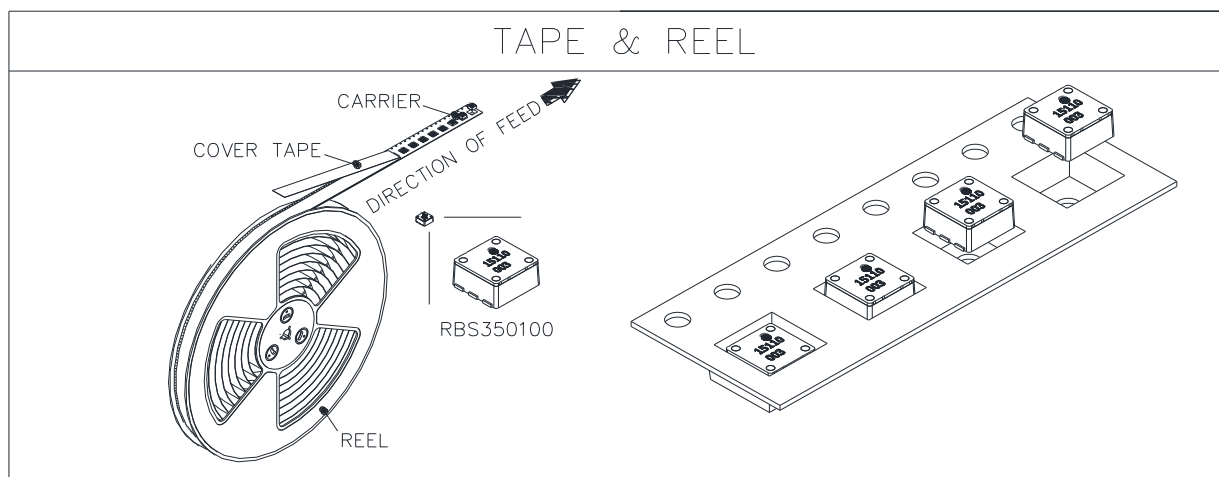

Tilt Sensor Switch

Item No.	RBS350100T	Description	Ball-Contact	Version	11
Page	3 of 15		Publish Date	Jul. 03, 2018	

● TILT ANGLE RANGE

I. Clarification:

1. Element with respect to the space Z axis inclination angle α is within 30° , can be normal actuation.
2. Component rotation angle Θ exceeding 75° , the output signal will be switched.

II. Fig. 3

	E1	E2
	0	1
	0	0
	1	0
	1	1

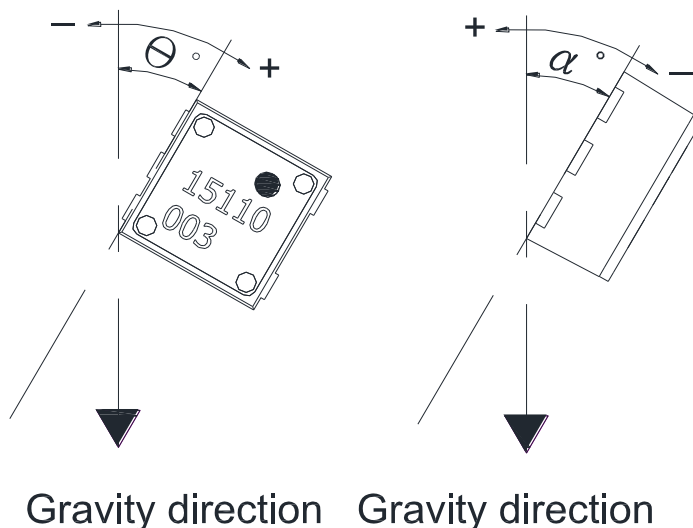

Tilt Sensor Switch

Item No.	RBS350100T	Description	Ball-Contact	Version	11
Page	4 of 15		Publish Date	Jul. 03, 2018	

III. Fig. 4

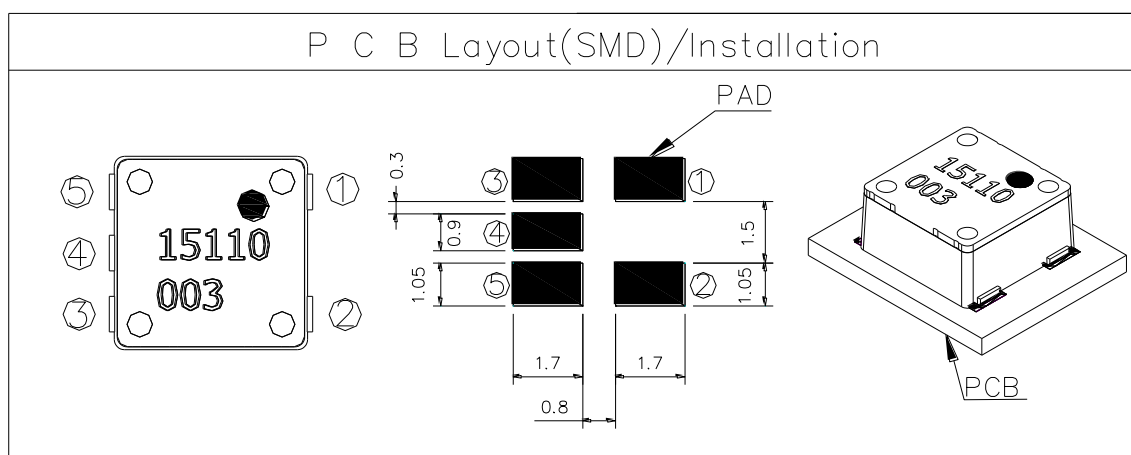
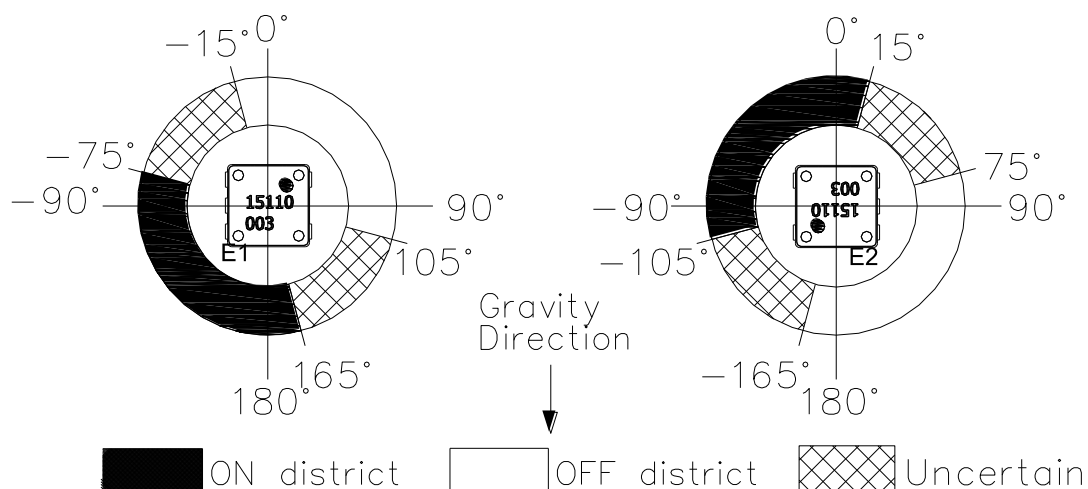

Tilt Sensor Switch

Item No.	RBS350100T	Description	Ball-Contact	Version	11
Page	5 of 15		Publish Date	Jul. 03, 2018	

● CIRCUIT SUGGESTED

Application Circuit

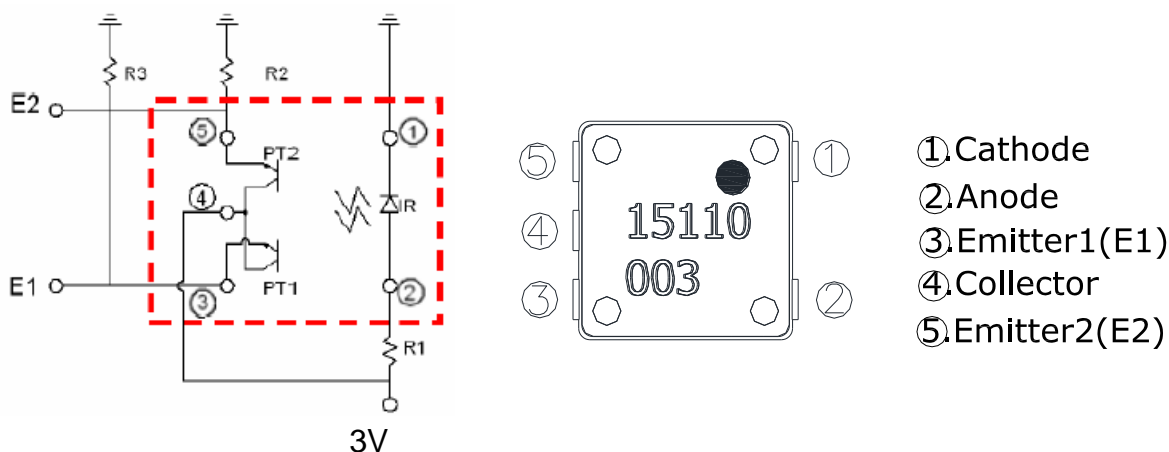

Note :

E1 : Output current of phototransistors PT1

E2 : Output current of phototransistors PT2

ON : Output current of phototransistors : 100μA or more

OFF : Output current of phototransistors : 20μA or less

Output current of ON/OFF is output when device is at a standstill



Tilt Sensor Switch

Item No.	RBS350100T	Description	Ball-Contact	Version	11
Page	6 of 15		Publish Date	Jul. 03, 2018	

● Recommended current and voltage

Input Current (mA)	Operating Voltage (V)	Conditions
3.5	3	$V_{CE}=3V$ $R_1=510\text{ ohm}$ $R_2、R_3=22K\text{ ohm}$

Input Current (mA)	Operating Voltage (V)	Conditions
3.5	3.3	$V_{CE}=3.3V$ $R_1=560\text{ ohm}$ $R_2、R_3=22\text{ K ohm}$

* Please refer to above Application Circuit for designing electrical circuit.

● Absolute Maximum Rating ($T_a=25^{\circ}\text{C}$)

Item		Symbol	Rating	Unit
Input	Power Dissipation	P_d	75	mW
	Reverse Voltage	V_R	5	V
	Forward Current	I_F	50	mA
	Peak Forward Current (*1)	I_{FP}	1	A
Output	Collector Power Dissipation	P_C	100	mW
	Collector Current	I_c	20	mA
	C-E Voltage	V_{CEO}	30	V
	E-C Voltage	V_{ECO}	5	V
Operating Temperature		T_{opr}	-25~+85	$^{\circ}\text{C}$
Storage Temperature		T_{stg}	-40~+85	$^{\circ}\text{C}$
Soldering Temperature (*2)		T_{sol}	260	$^{\circ}\text{C}$

(*1) $t_w=100\text{ uSec.}$, $T=10\text{ mSec.}$

(*2) $t=5\text{ Sec}$



Tilt Sensor Switch

Item No.	RBS350100T	Description	Ball-Contact	Version	11
Page	7 of 15		Publish Date	Jul. 03, 2018	

● Optical/Electrical Characteristics (Ta=25°C)

Parameter		Symbol	Conditions	MIN.	TYP.	MAX.	Unit	
Input	Forward voltage	V_F	$I_F=20mA$	-	1.25	1.3	V	
	Reverse current	I_R	$V_R=5V$	-	-	10	μA	
*1 Output	Collector dark current	I_{CE}	$V_{CE}=20V$	-	-	50	nA	
*1 Coupling Characteristics	Collector current	I_C	$V_{CE}=3.0V, R_1=510\Omega$	100	-	-	μA	
	*2 Leak current	I_{LEAK}	$V_{CE}=3.0V, R_1=510\Omega$	-	-	20	μA	
	Response Time	Rise time	t_r	$V_{CE}=3.0V, I_C=100\mu A$ $R_L=1000\Omega$	-	50	150	us
		Fall time	t_r		-	50	150	us
Collector-emitter Saturation voltage		$V_{CE(sat)}$	$I_F=2mA, I_C=100\mu A$	-	-	0.3	V	
Operation Angle		θ	Fig. 4				°	

*1 Output and coupling characteristics are common to the both phototransistors.

*2 Leak current is the output of transistor when $\theta=0^\circ$ or $\pm 90^\circ$, $\phi=0^\circ$ and $I_C=OFF$.



Tilt Sensor Switch

Item No.	RBS350100T	Description	Ball-Contact	Version	11
Page	8 of 15		Publish Date	Jul. 03, 2018	

● Typical Electrical / Optical Characteristics Curves (Ta=25°C)

Fig.1 Power Dissipation vs. Ambient Temperature

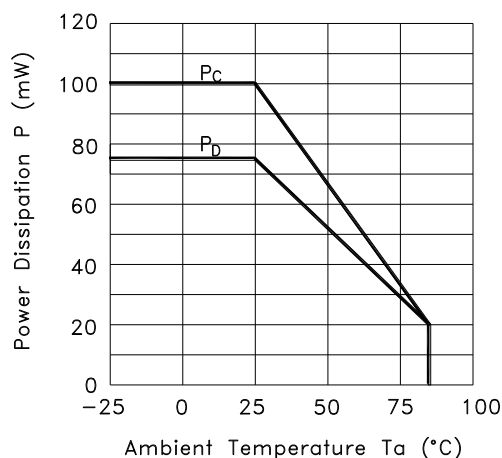

Fig.2 Forward Current vs. Forward Voltage

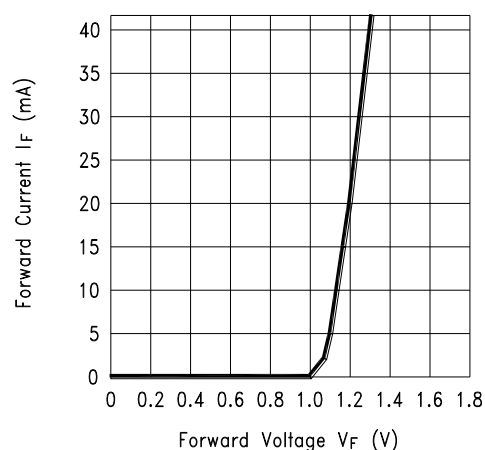

Fig.3 Collector Current vs. Collector-emitter Voltage

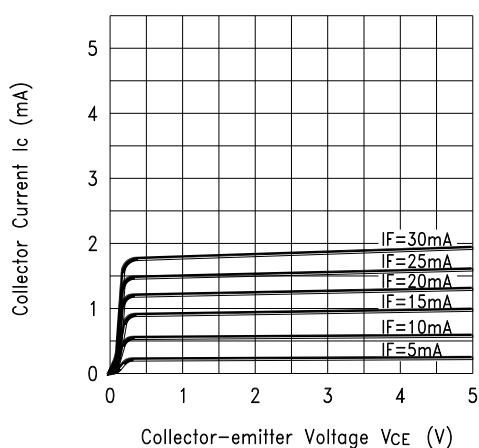
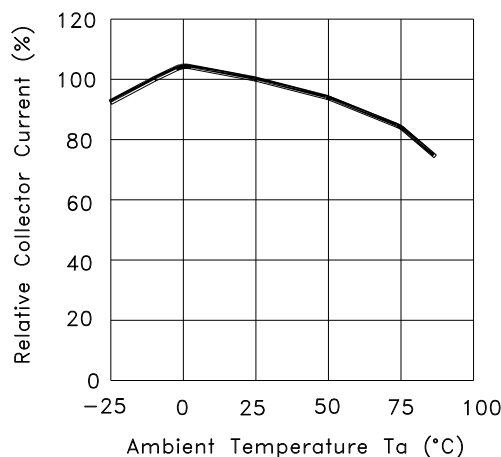

Fig.4 Collector Current vs. Ambient Temperature



Tilt Sensor Switch

Item No.	RBS350100T	Description	Ball-Contact	Version	11
Page	9 of 15		Publish Date	Jul. 03, 2018	

Fig.5 Collector-emitter Saturation Voltage vs. Ambient Temperature

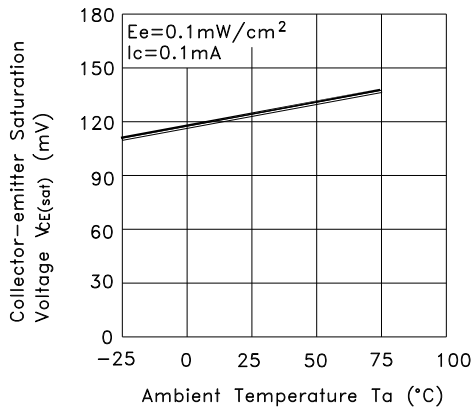

Fig.6 Response Time vs. Load Resistance

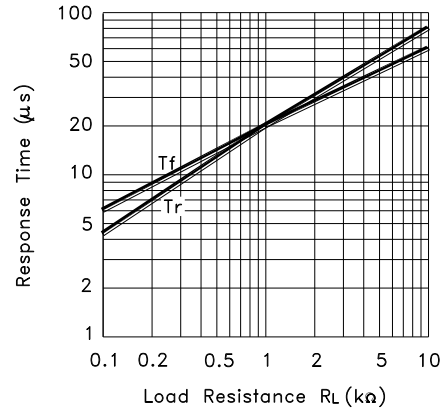
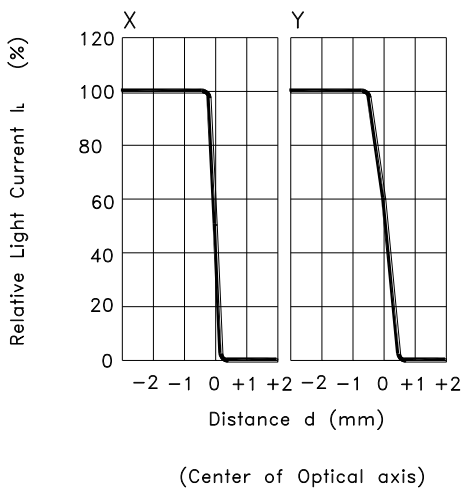
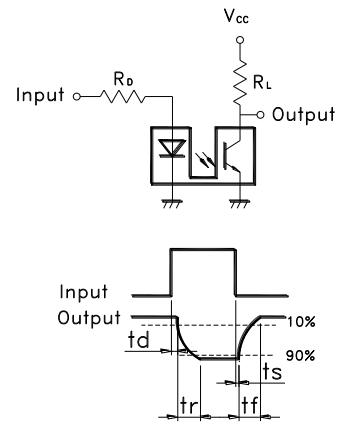

Fig.7 Sensing Position Characteristics (Typical)



Test Circuit for Response Time



Tilt Sensor Switch

Item No.	RBS350100T	Description	Ball-Contact	Version	11
Page	10 of 15		Publish Date	Jul. 03, 2018	

● RELIABLE TEST ITEMS

Reliable Test for RBS350100T

	Test Item	Contents
1	IR Reflow	Peak temp.=255~260°C
2	Operating Temperature	-25°C ~ 85°C
3	Storage Temperature	-40°C ~ 85°C
4	Humidity	40 °C / 95 %RH
5	Mechanical Life	2Hz, horizontal 1,000,000 times
6	Electrical Life	I _F =20 mA, V _{CE} =5 V TIME: 30,000 hrs

● SOLDERING CONDITION

Following soldering conditions are for reference only, please use soldering information that solder paste manufacturer recommends.

Condition Suitable Production Process	Soldering Temperature	Soldering Time	Wattage of Manual Soldering	Type
IR Reflow	Please refer to following < Table of classification Reflow profile > and Fig. 5		-	SMD
Manual Soldering	300±5°C	< 3 seconds max.	30W or Temperature- controlled manual soldering	SMD



Tilt Sensor Switch

Item No.	RBS350100T	Description	Ball-Contact	Version	11
Page	11 of 15		Publish Date	Jul. 03, 2018	

< Table of classification Reflow profile >

Item	Pb process	Pb free process
Pre-heat and Soak Temperature min.(T _{min}) Temperature max.(T _{max}) Time (T _{min} to T _{max})(t _s)	100°C 150°C 60-120 seconds	150°C 200°C 60-120 seconds
Average ram-up Rate (T _{max} to T _p)	3°C/second max.	3 °C/second max.
Liquidous Temperature (TL) Time at Liquidous (tL)	183°C 60-150 seconds	217°C 60-150 seconds
Peak package body Temperature (T _p)*	230°C ~235°C *	255°C ~260°C *
Classification temperature(T _c)	235°C	260°C
Time(tp)** within 5 °C of the specified classification temperature (T _c)	20** seconds	30** seconds
Average ram-down Rate (T _p to T _{max})	6°C/second max.	6°C/second max.
Time 25 °C to peak temperature	6 minutes max.	8 minutes max.
* Tolerance for peak profile temperature (T _p) is defined as a supplier minimum and a user maximum. ** Tolerance for time at peak profile temperature (tp) is defined as a supplier minimum and a user maximum.		



Tilt Sensor Switch

Item No.	RBS350100T	Description	Ball-Contact	Version	11
Page	12 of 15		Publish Date	Jul. 03, 2018	

Fig. 5

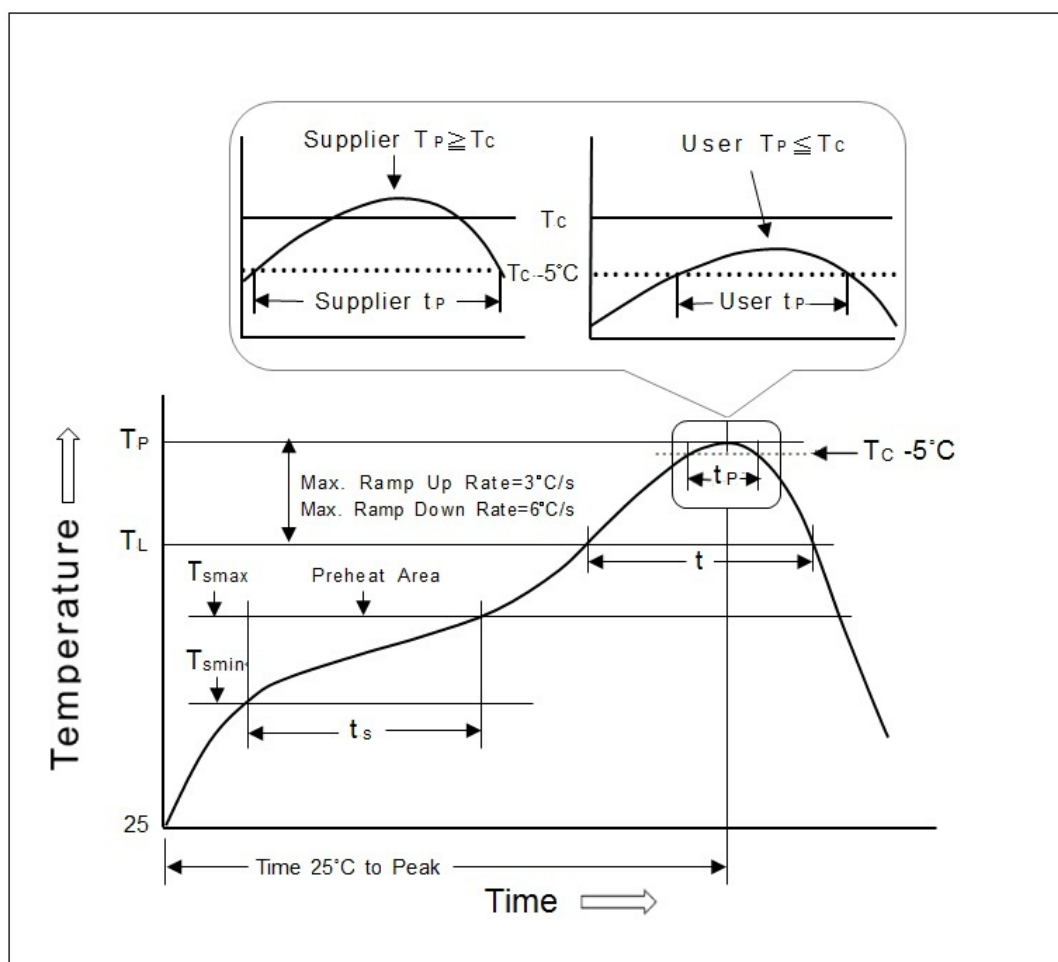

Tilt Sensor Switch

Item No.	RBS350100T	Description	Ball-Contact	Version	11
Page	13 of 15		Publish Date	Jul. 03, 2018	

● PACKAGE

	Part Number	Package	Quantity	Total	Dimension (mm)
1.	RBS350100T	Tape & reel	3,500 pcs	3,500 pcs	φ300*12.5H
		Inner box	3 reels	10,500 pcs	355L*340W*68H
		Carton	4 boxes	42,000 pcs	373L*358W*309H

※ Package shown as below for reference.

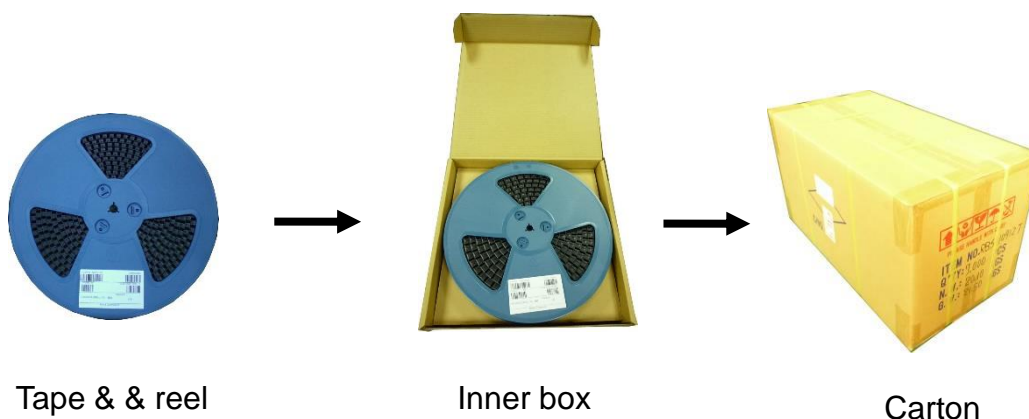

Tilt Sensor Switch

Item No.	RBS350100T	Description	Ball-Contact	Version	11
Page	14 of 15		Publish Date	Jul. 03, 2018	

● NOTE:

I. Design:

1. Caution should be taken not to overload with instantaneous voltage at the turning ON and OFF of the circuit.
2. When using the pulse drive care must be taken to keep the average current with the rate figures.
3. Avoid close to or direct circuit connect to magnetic devices. (ex: Relay, transformer ...and so on)
4. Don't try to clean the switch with a solvent or similar substance after the soldering process.
5. The switch might be damaged if using the water-soluble flux.

II. Storage:

1. In order to avoid the absorption of moisture, it is recommended to solder as soon as possible after unpacking the sealed bag.
2. If the bag is still sealed, to store it in the environment as following:
 - (1) Temperature: 5°C - 30°C (40°F) ;
Relative humidity: RH 60% MAX.
 - (2) After the packaging bag is opened to perform the IR reflow or soldering process, the necessary conditions are as below:
 - a. Completed within 168 hours
 - b. Stored at less than 30% RH.
 - (3) If parts is being unable to conform to condition of (2)a or (2)b, it must be baking before it goes to welding again.
 - (4) If baking is required, device must be baked under below condition:
48 hours at 60°C +/-3°C.



Tilt Sensor Switch

Item No.	RBS350100T	Description	Ball-Contact	Version	11
Page	15 of 15		Publish Date	Jul. 03, 2018	

III. Others:

1. If the products is intended to be used for other endurance equipment requiring higher safety and reliability such as life support system, space and aviation devices, disaster and safety system, it's necessary to make verification of conformity or contact us for the details before using.
2. To prevent damaging IR and PT, please make electrostatic protective treatment, for example: wearing a conductive wrist strap or antistatic gloves during production process, grounding machinery etc.

● Remark:

For the continued product improvement as one of the company policy, specifications may change or update without notice. The latest information can be obtained through our sales offices. Normally, all products are supplied under our standard conditions.



Компания «Life Electronics» занимается поставками электронных компонентов импортного и отечественного производства от производителей и со складов крупных дистрибьюторов Европы, Америки и Азии.

С конца 2013 года компания активно расширяет линейку поставок компонентов по направлению коаксиальный кабель, кварцевые генераторы и конденсаторы (керамические, пленочные, электролитические), за счёт заключения дистрибьюторских договоров

Мы предлагаем:

- Конкурентоспособные цены и скидки постоянным клиентам.
- Специальные условия для постоянных клиентов.
- Подбор аналогов.
- Поставку компонентов в любых объемах, удовлетворяющих вашим потребностям.
- Приемлемые сроки поставки, возможна ускоренная поставка.
- Доставку товара в любую точку России и стран СНГ.
- Комплексную поставку.
- Работу по проектам и поставку образцов.
- Формирование склада под заказчика.
- Сертификаты соответствия на поставляемую продукцию (по желанию клиента).
- Тестирование поставляемой продукции.
- Поставку компонентов, требующих военную и космическую приемку.
- Входной контроль качества.
- Наличие сертификата ISO.

В составе нашей компании организован Конструкторский отдел, призванный помогать разработчикам, и инженерам.

Конструкторский отдел помогает осуществить:

- Регистрацию проекта у производителя компонентов.
- Техническую поддержку проекта.
- Защиту от снятия компонента с производства.
- Оценку стоимости проекта по компонентам.
- Изготовление тестовой платы монтаж и пусконаладочные работы.



Тел: +7 (812) 336 43 04 (многоканальный)

Email: org@lifeelectronics.ru