

Hazardous Location Industrial VRS Magnetic Speed Sensors



DESCRIPTION

Hazardous Location VRS sensors are designed for use in locations where explosion-proof or intrinsically safe sensors are required.

Passive VRS (Variable Reluctance Speed) Magnetic Speed sensors are simple, rugged devices that do not require an external voltage source for operation.

A permanent magnet in the sensor establishes a fixed magnetic field. The approach and passing of a ferrous metal target near the sensor's pole piece (sensing area) changes the flux of the magnetic field, dynamically changing its strength. This change in magnetic field strength induces a current into a coil winding which is attached to the output terminals.

FEATURES

- Self-powered operation
- Direct conversion of actuator speed to output frequency
- Simple installation
- No moving parts
- Designed for use over a wide range of speeds
- Adaptable to a wide variety of configurations
- Customized VRS products for unique speed sensing applications
- Housing diameters: 3/4 in, 5/8 in
- Housing material/style: stainless steel threaded
- Terminations: MS3106 connector, preleaded
- Output voltages: 30 Vp-p to 60 Vp-p

The output signal of a VRS sensor is an ac voltage that varies in amplitude and wave frequency as the speed of the monitored device changes, and is usually expressed in peak to peak voltage (Vp-p).

One complete waveform (cycle) occurs as each target passes the sensor's pole piece. If a standard gear were used as a target, this output signal would resemble a sine wave if viewed on an oscilloscope.

Honeywell also offers VRS sensors for general purpose, high output, power output, high resolution and high temperature, as well as low-cost molded versions.

POTENTIAL APPLICATIONS

- Engine RPM (revolutions per minute) measurement on aircraft, automobiles, boats, buses, trucks and rail vehicles
- Motor RPM on oil and gas drilling equipment and machinery
- Motor RPM measurement on drills, grinders, lathes and automatic screw machines
- Process speed measurement on food, textile, paper, woodworking, printing, tobacco and pharmaceutical industry machinery
- Motor speed measurement of electrical generating equipment in grain elevators, sawmills and other potentially explosive environments
- Speed measurement of pumps, blowers, mixers, exhaust
- Gear speed measurement

Hazardous Location

3/4 INCH EXPLOSION-PROOF SENSORS (All dimensions for reference only. mm/[in])

When properly installed using the explosion containment method, all 3070X and catalog listings on this page are certified for use in hazardous locations as follows: Class I, Groups A, B, C, D; Class II Groups E, F, G; Class III.

These catalog listings have been tested to and meet the requirements of applicable U.S. and Canadian specifications for the locations described above.

General Specifications

Parameter	Characteristic	Parameter	Characteristic
Min. output voltage	60 Vp-p	Inductance	115 mH max.
Coil resistance	191 Ohm to 280 Ohm	Gear pitch range	12 DP (module 2.11) or coarser
Pole piece diameter	4,75 mm [0.187 in]	Optimum actuator	8 DP (module 3.17) ferrous metal gear
Min. surface speed	0,38 m/s [15 in/s] typ.	Max. operating frequency	40 kHz typ.
Operating temp. range	-73 °C to 93 °C [-100 °F to 200 °F]	Vibration	Mil-Std 202F Method 204D
Mounting thread	3/4-20 UNEF-2A	Termination	18 AWG PVC-Insulated Leads

Test Condition Specifications

Parameter	Characteristic
Surface speed	25 m/s [1000 in/s]
Gear	8 DP (module 3.17)
Air gap	0,127 mm [0.005 in]
Load resistance	100 kOhm

Catalog Listing	Thread Length (A)	Weight	
3070A	45 mm [1.8 in]	294 g [10.5 oz]	
3070A35	88 mm [3.5 in]	322 g [11.5 oz]	

Industrial VRS Magnetic Speed Sensors

5/8 INCH EXPLOSION-PROOF SENSORS (All dimensions for reference only. mm/[in])

When properly installed using the explosion containment method, the 3090X catalog listings on this page are certified for use in hazardous locations as follows: Class I, Groups A, B, C, D; Class II Groups E, F, G; Class III.

These catalog listings have been tested to and meet the requirements of applicable U.S. and Canadian specifications for the locations described above.

The catalog listings on this page conform to standards:  II 3 G EEx nA II T6.

General Specifications

Parameter	Characteristic	Parameter	Characteristic
Min. output voltage	60 Vp-p	Inductance	115 mH max.
Coil resistance	191 Ohm to 280 Ohm	Gear pitch range	12 DP (module 2.11) or coarser
Pole piece diameter	4,75 mm [0.187 in]	Optimum actuator	8 DP (module 3.17) ferrous metal gear
Minimum surface speed	0,38 m/s [15 in/s] typ.	Maximum operating frequency	40 kHz typ.
Operating temp. range	-73 °C to 93 °C [-100 °F to 200 °F]	Vibration	Mil-Std 202F Method 204D
Mounting thread	5/8-20 UNF-2A	Termination	18 AWG PVC-insulated leads

Test Condition Specifications

Parameter	Characteristic
Surface speed	25 m/s [1000 in/s]
Gear	8 DP (module 3.17)
Air gap	0,127 mm [0.005 in]
Load resistance	100 kOhm

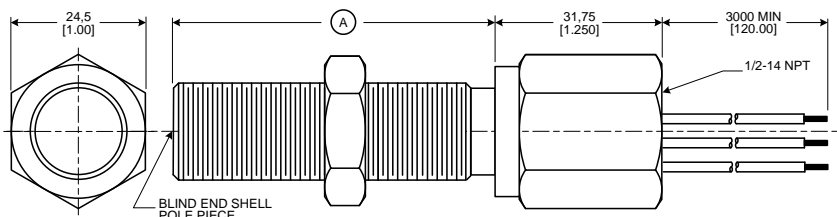
Catalog Listing	Thread Length (A)	Weight	
3090A	45 mm [1.8 in]	280 g [9.0 oz]	
3090A35	88 mm [3.5 in]	366 g [10.0 oz]	

Hazardous Location

5/8 INCH (M16*) INTRINSICALLY SAFE VRS SENSORS (All dimensions for reference only. mm/[in])

*Contact Honeywell for availability of metric mounting thread versions.

When properly installed using the intrinsic safety protection method connected per the control drawings on pages 6 and 7, catalog listings 3042A is intrinsically safe for hazardous locations as follows:

Class I, Groups A, B, C, D.

This product has been tested to and meets the requirements of applicable U.S. and Canadian specifications for the locations described above.

General Specifications

Parameter	Characteristic	Parameter	Characteristic
Min. output voltage	30 Vp-p	Inductance	26 mH max.
Coil resistance	150 Ohm	Gear pitch range	16 DP (module 1.58) or coarser
Pole piece diameter	3,9 mm [0.156 in]	Optimum actuator	12 DP (module 3.17) ferrous metal gear
Min. surface speed	0,38 m/s [15 in/s] typ.	Max. operating frequency	40 kHz typ.
Operating temp. range	-55 °C to 120 °C [-67 °F to 250 °F]	Vibration	N/A
Mounting thread	5/8-18 UNF-2A	Termination	MS3106 connector

Test Condition Specifications

Parameter	Characteristic
Surface speed	25 m/s [1000 in/s]
Gear	8 DP (module 3.17)
Air gap	0,127 mm [0.005 in]
Load resistance	100 kOhm

Catalog Listing	Weight	
3042A	70 g [2.5 oz]	

Industrial VRS Magnetic Speed Sensors

5/8 INCH (M16*) INTRINSICALLY SAFE VRS SENSORS (All dimensions for reference only. mm/[in])

*Contact Honeywell for availability of metric mounting thread versions.

When properly installed using the intrinsic safety protection method connected per the control drawings on pages 6 and 7, catalog listing 3042H20 is intrinsically safe for hazardous locations as follows:

Class I, Groups A, B, C, D; Class II Groups E, F, G; Class III.

This product has been tested to and meets the requirements of applicable U.S. and Canadian specifications for the locations described above.

General Specifications

Parameter	Characteristic	Parameter	Characteristic
Min. output voltage	30 Vp-p	Inductance	26 mH max.
Coil resistance	150 Ohm	Gear pitch range	16 DP (module 1.58) or coarser
Pole piece diameter	3,9 mm [0.156 in]	Optimum actuator	12 DP (module 3.17) ferrous metal gear
Min. surface speed	0,38 m/s [15 in/s] typ.	Max. operating frequency	40 kHz typ.
Operating temp. range	-55 °C to 120 °C [-67 °F to 250 °F]	Vibration	N/A
Mounting thread	5/8-18 UNF-2A	Termination	18 AWG PVC-insulated leads

Test Condition Specifications

Parameter	Characteristic
Surface speed	25 m/s [1000 in/s]
Gear	8 DP (module 3.17)
Air gap	0,127 mm [0.005 in]
Load resistance	100 kOhm

Catalog Listing	Weight	
3042AH20	140 g [5.0 oz]	

Hazardous Location

CONTROL DRAWING FOR SINGLE CHANNEL BARRIERS

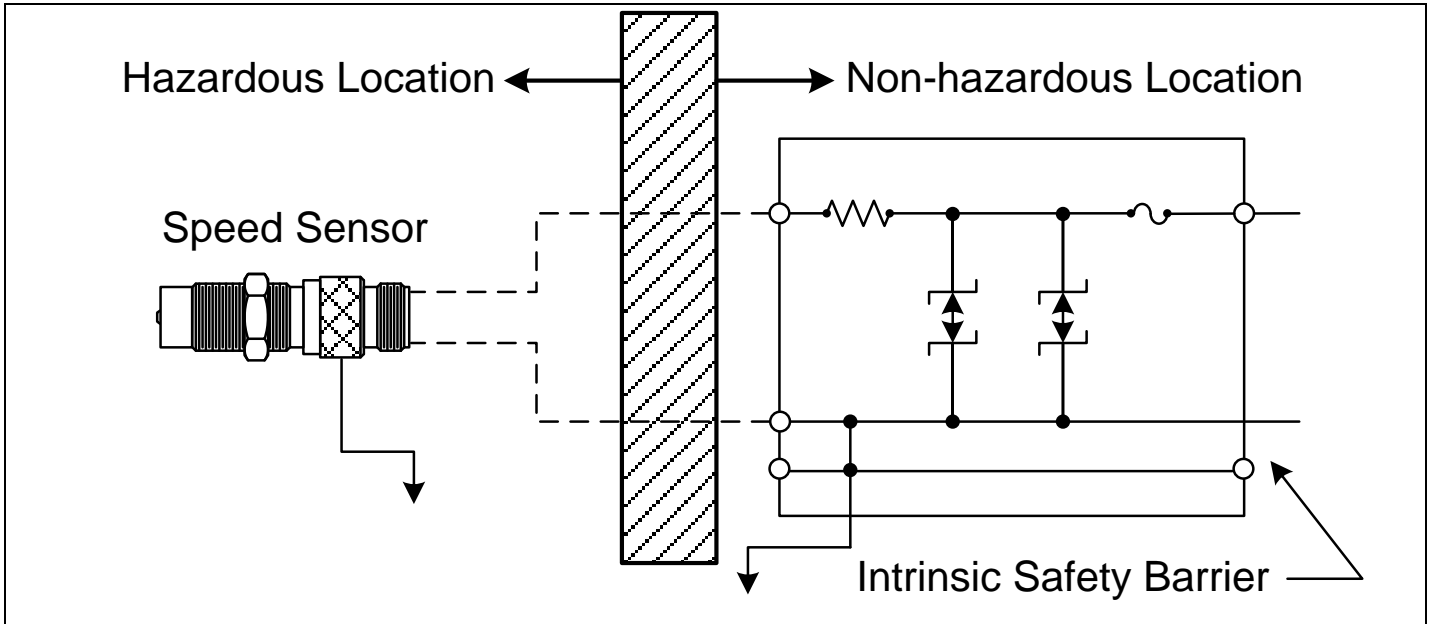

HAZARDOUS LOCATIONS

Catalog listing 3042H20:

- Class I, Groups A, B, C, D
- Class II, Groups E, F, G
- Class III

Catalog listing 3042A:

- Class I, Groups A, B, C, D

ENTITY PARAMETERS

$V_{max} = 24\text{ V}$, $I_{max} = 35\text{ mA}$, $L_i = 26\text{ mH}$, $C_i = 0\text{ }\mu\text{F}$

Any barrier (see General Notes) with entity parameters connected in accordance with barrier manufacturers instructions of:

$$V_{max} \geq V_{oc} \quad C_a \geq C_i + \text{cable capacitance}$$

$$I_{max} \geq I_{sc} \quad L_a \geq L_i + \text{cable inductance}$$

SYSTEM PARAMETERS

Any barrier (see General Notes) having one of the following specified parameters:

V_{max}	R_{min}	V_{max}	R_{min}	V_{max}	R_{min}
30	707	20	421	10	136
25	580	15	278	5	1

GENERAL NOTES

1. For jurisdictions requiring certification to the applicable Canadian standards, the barrier must be CSA Certified and the system must be installed in accordance with the Canadian Electrical Code Part 1.
2. For jurisdictions requiring certification to the applicable Occupational Safety and Health Administration (OSHA) standards, the barrier must be CSA NRTL or equivalent and the system must be installed in accordance with the National Electrical Code (NEC), article 504 or ANSI/NFPA 70.

SENSOR GROUNDING

Catalog listing 3042A: Sensor housing must be connected to intrinsically safe system ground during installation.

Catalog listing 3042H20: Green wire must be connected to intrinsically safe system ground.

Exia = Intrinsically Safe, Sécurité Intrinsèque

Industrial VRS Magnetic Speed Sensors

CONTROL DRAWING FOR DUAL CHANNEL BARRIERS

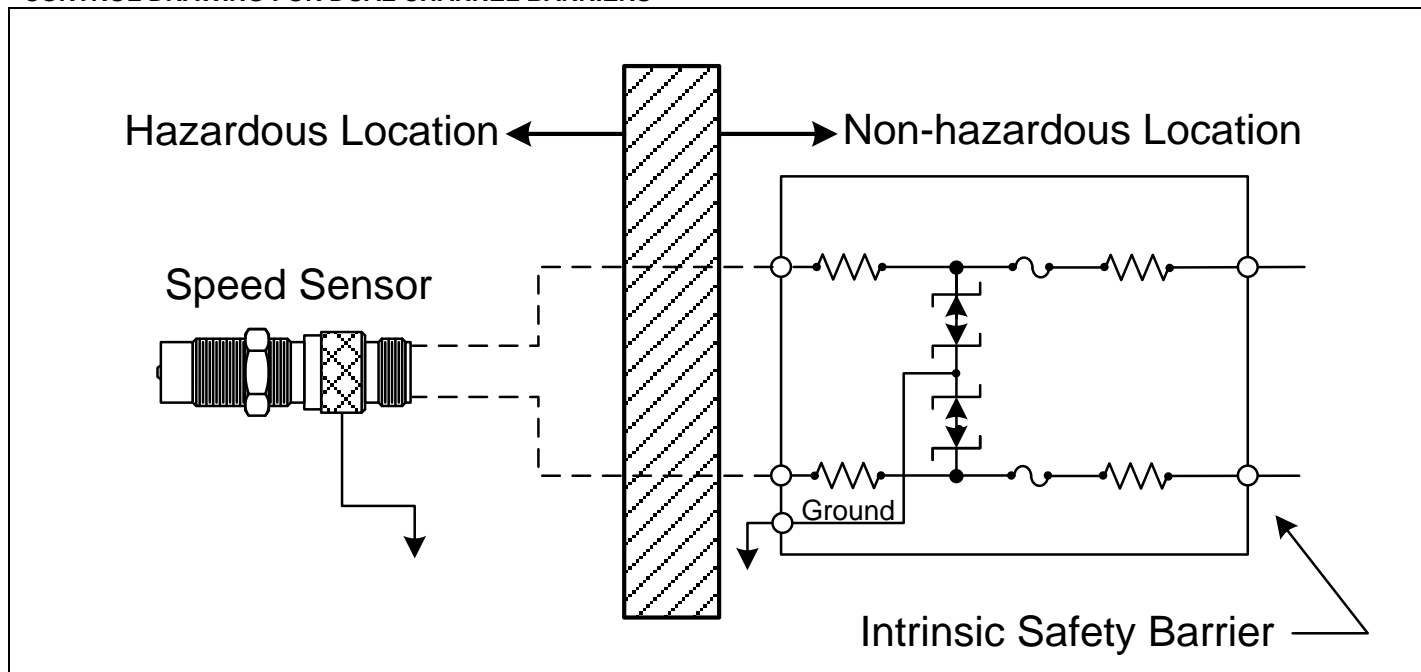

HAZARDOUS LOCATIONS

Catalog listing 3042H20:

- Class I, Groups A, B, C, D
- Class II, Groups E, F, G
- Class III

Catalog listing 3042A:

Class I, Groups A, B, C, D

ENTITY PARAMETERS

$V_{max} = 24\text{ V}$, $I_{max} = 35\text{ mA}$, $L_i = 26\text{ mH}$, $C_i = 0\text{ }\mu\text{F}$

Any barrier (see General Notes) with entity parameters connected in accordance with barrier manufacturers instructions of:

$$V_{max} \geq V_{oc} \quad C_a \geq C_i + \text{cable capacitance}$$

$$I_{max} \geq I_{sc} \quad L_a \geq L_i + \text{cable inductance}$$

SYSTEM PARAMETERS

Any barrier (see General Notes) having one of the following specified parameters:

V_{max}	R_{min}	V_{max}	R_{min}	V_{max}	R_{min}
30	1414	20	842	10	272
25	1160	15	556	5	2

GENERAL NOTES

1. For jurisdictions requiring certification to the applicable Canadian standards, the barrier must be CSA Certified and the system must be installed in accordance with the Canadian Electrical Code Part 1.
2. For jurisdictions requiring Certification to the applicable Occupational Safety and Health Administration (OSHA) standards, the barrier must be CSA NRTL or equivalent and the system must be installed in accordance with the National Electrical Code (NEC), article 504 or ANSI/NFPA 70.

SENSOR GROUNDING

Catalog listing 3042A: Sensor housing must be connected to intrinsically safe system ground during installation.

Catalog listing 3042H20: Green wire must be connected to intrinsically safe system ground.

Exia = Intrinsically Safe, Sécurité Intrinsèque

WARNING

PERSONAL INJURY

DO NOT USE these products as safety or emergency stop devices or in any other application where failure of the product could result in personal injury.

Failure to comply with these instructions could result in death or serious injury.

WARRANTY/REMEDY

Honeywell warrants goods of its manufacture as being free of defective materials and faulty workmanship. Honeywell's standard product warranty applies unless agreed to otherwise by Honeywell in writing; please refer to your order acknowledgement or consult your local sales office for specific warranty details. If warranted goods are returned to Honeywell during the period of coverage, Honeywell will repair or replace, at its option, without charge those items it finds defective. **The foregoing is buyer's sole remedy and is in lieu of all other warranties, expressed or implied, including those of merchantability and fitness for a particular purpose. In no event shall Honeywell be liable for consequential, special, or indirect damages.**

While we provide application assistance personally, through our literature and the Honeywell web site, it is up to the customer to determine the suitability of the product in the application.

Specifications may change without notice. The information we supply is believed to be accurate and reliable as of this printing. However, we assume no responsibility for its use.

WARNING

MISUSE OF DOCUMENTATION

- The information presented in this product sheet is for reference only. Do not use this document as a product installation guide.
- Complete installation, operation, and maintenance information is provided in the instructions supplied with each product.

Failure to comply with these instructions could result in death or serious injury.

SALES AND SERVICE

Honeywell serves its customers through a worldwide network of sales offices, representatives and distributors. For application assistance, current specifications, pricing or name of the nearest Authorized Distributor, contact your local sales office or:

E-mail: info.sc@honeywell.com

Internet: www.honeywell.com/sensing

Phone and Fax:

Asia Pacific	+65 6355-2828
	+65 6445-3033 Fax
Europe	+44 (0) 1698 481481
	+44 (0) 1698 481676 Fax
Latin America	+1-305-805-8188
	+1-305-883-8257 Fax
USA/Canada	+1-800-537-6945
	+1-815-235-6847
	+1-815-235-6545 Fax

Sensing and Control
Honeywell
1985 Douglas Drive North
Golden Valley, MN 55422
www.honeywell.com

005879-2-EN
March 2012
Copyright © 2012 Honeywell International Inc. All rights reserved.

Honeywell

Компания «Life Electronics» занимается поставками электронных компонентов импортного и отечественного производства от производителей и со складов крупных дистрибьюторов Европы, Америки и Азии.

С конца 2013 года компания активно расширяет линейку поставок компонентов по направлению коаксиальный кабель, кварцевые генераторы и конденсаторы (керамические, пленочные, электролитические), за счёт заключения дистрибьюторских договоров

Мы предлагаем:

- Конкурентоспособные цены и скидки постоянным клиентам.
- Специальные условия для постоянных клиентов.
- Подбор аналогов.
- Поставку компонентов в любых объемах, удовлетворяющих вашим потребностям.
- Приемлемые сроки поставки, возможна ускоренная поставка.
- Доставку товара в любую точку России и стран СНГ.
- Комплексную поставку.
- Работу по проектам и поставку образцов.
- Формирование склада под заказчика.
- Сертификаты соответствия на поставляемую продукцию (по желанию клиента).
- Тестирование поставляемой продукции.
- Поставку компонентов, требующих военную и космическую приемку.
- Входной контроль качества.
- Наличие сертификата ISO.

В составе нашей компании организован Конструкторский отдел, призванный помогать разработчикам, и инженерам.

Конструкторский отдел помогает осуществить:

- Регистрацию проекта у производителя компонентов.
- Техническую поддержку проекта.
- Защиту от снятия компонента с производства.
- Оценку стоимости проекта по компонентам.
- Изготовление тестовой платы монтаж и пусконаладочные работы.



Тел: +7 (812) 336 43 04 (многоканальный)

Email: org@lifeelectronics.ru