

THIS DRAWING IS UNPUBLISHED. RELEASED FOR PUBLICATION 20  
 © COPYRIGHT 20 BY - ALL RIGHTS RESERVED.

REVISIONS					
P	LTR	DESCRIPTION	DATE	DWN	APVD
V		REDRAWN/REVISED PER ECO-17-001756	09NOV2017	GR	JO

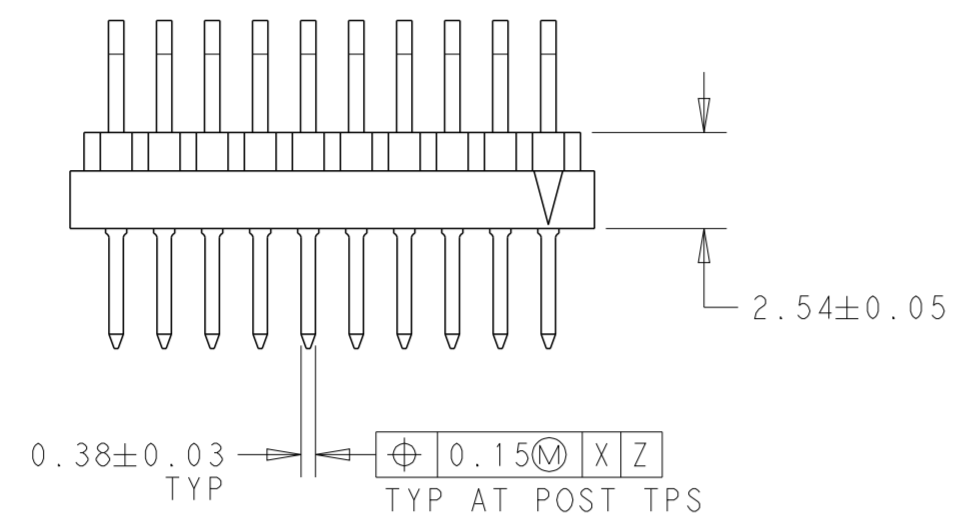

- 1 CONTACT AREAS PLATED WITH 0.76µm GOLD; SOLDER TAILS PLATED WITH 3.81µm MIN TIN-LEAD; ALL OVER 1.27µm MIN NICKEL
- 2. NOTE DELETED
- 3 THE NOTED DIMENSIONS APPLY AT THE INTERSECTION OF THE POST AND HOUSING.
- 4 CONTACT AREAS PLATED WITH 0.76µm GOLD; SOLDER TAILS PLATED WITH 3.81µm MIN TIN; ALL OVER 1.27µm MIN NICKEL
- 5. NOTE DELETED
- 6 FINISH: 0.03µm MIN GOLD ON GOLD PLATED AREA, 3.81µm MATTE TIN-LEAD ON TIN PLATED AREA, UNDER PLATING SHOULD BE 1.27µm NICKEL ON ENTIRE CONTACT. GOLD AND TIN PLATING MAY NOT OVERLAP.
- 7 FINISH: 0.03µm MIN GOLD ON GOLD PLATED AREA, 3.81µm MATTE TIN ON TIN PLATE AREA, UNDER PLATING SHOULD BE 1.27µm NICKEL ON ENTIRE CONTACT. GOLD AND TIN PLATING MAY NOT OVERLAP.
- 8. NOTE DELETED
- 9. NOTE DELETED
- 10. NOTE DELETED
- 11 MATERIAL: HOUSING: LCP  
COLOR-BLACK  
CONTACT: COPPER ALLOY

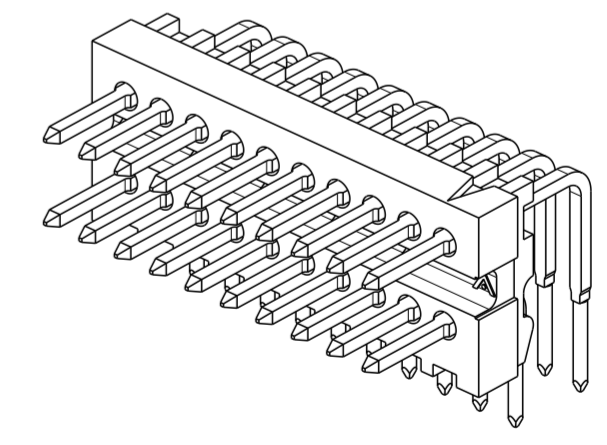
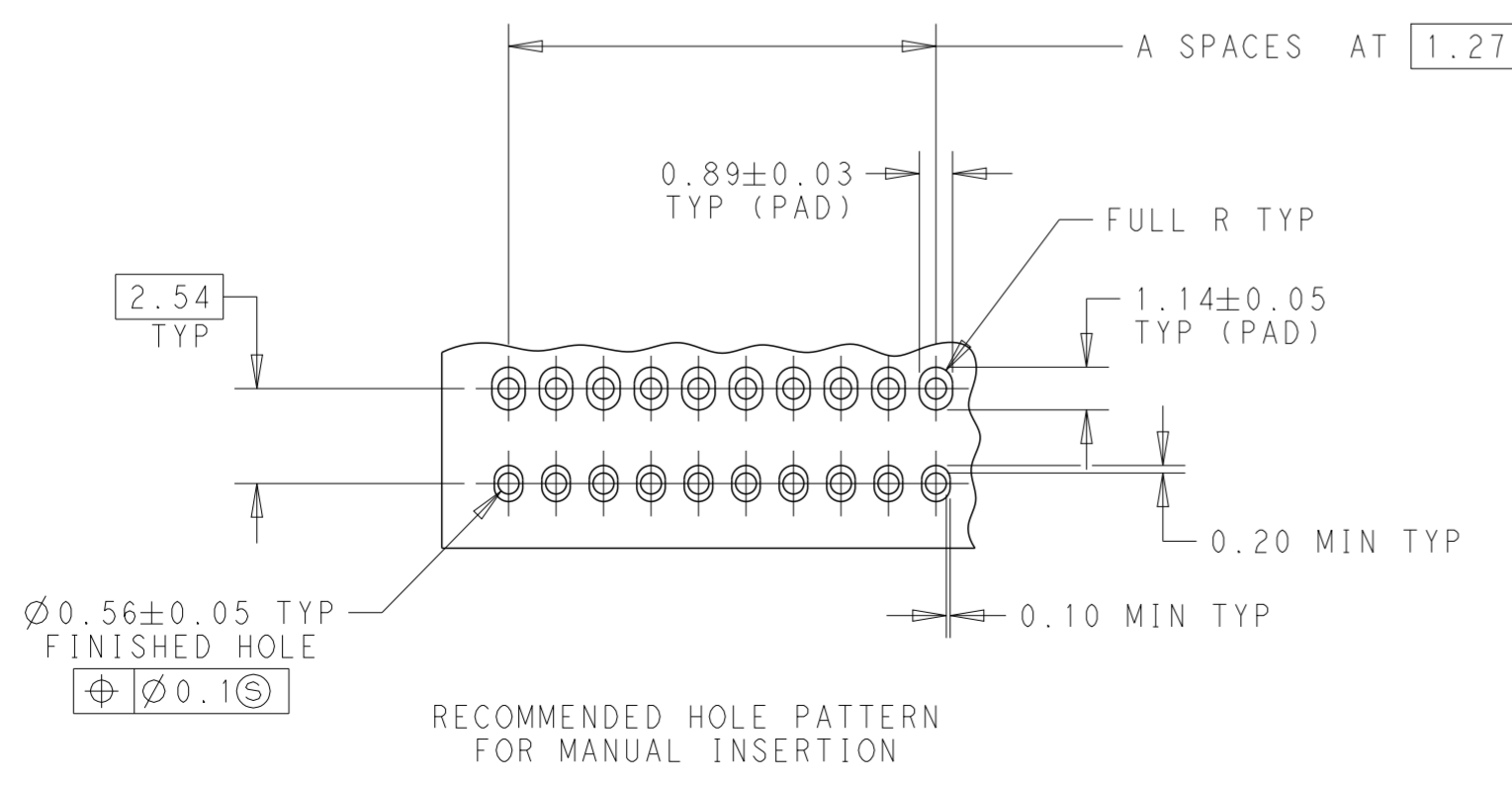
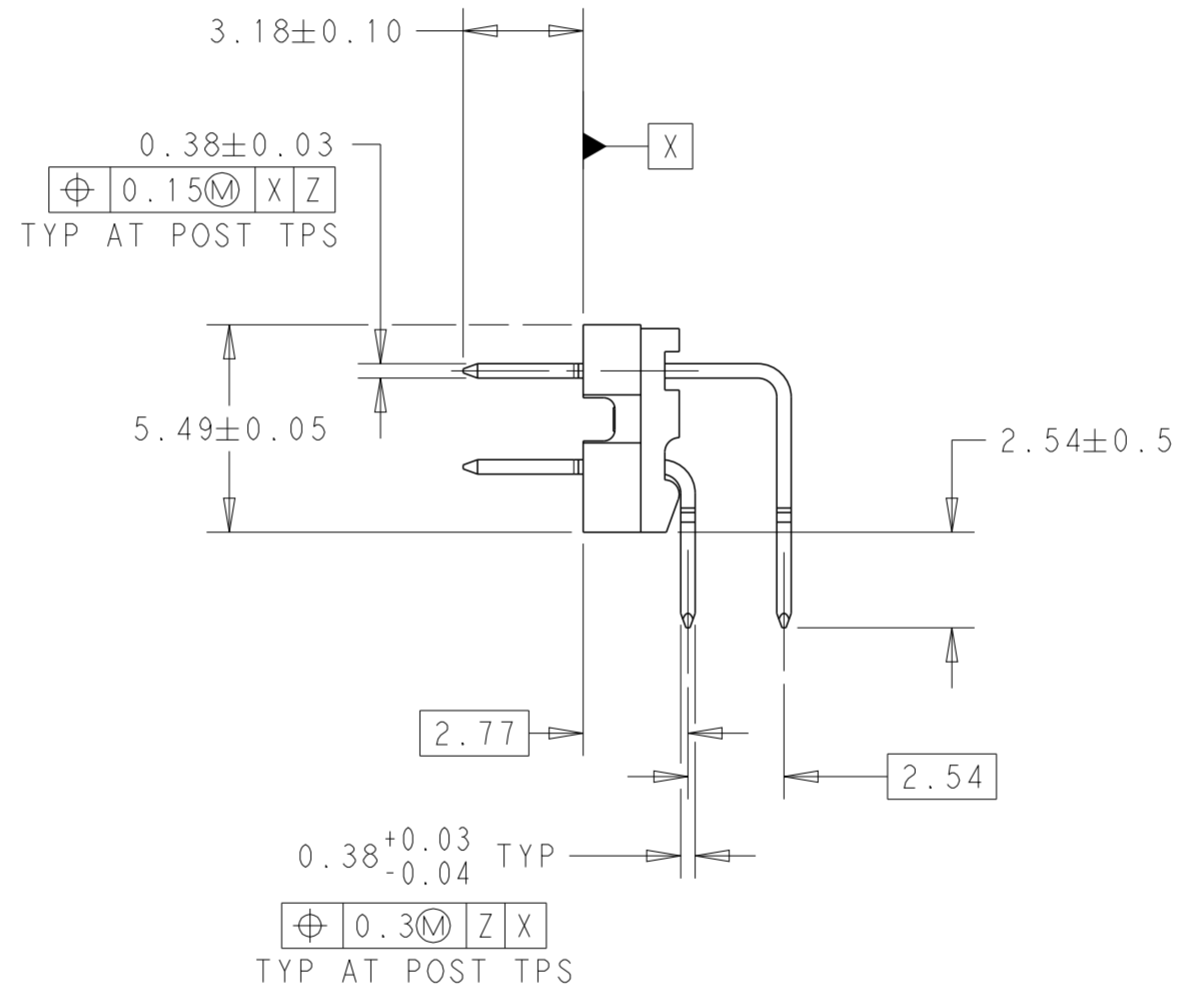
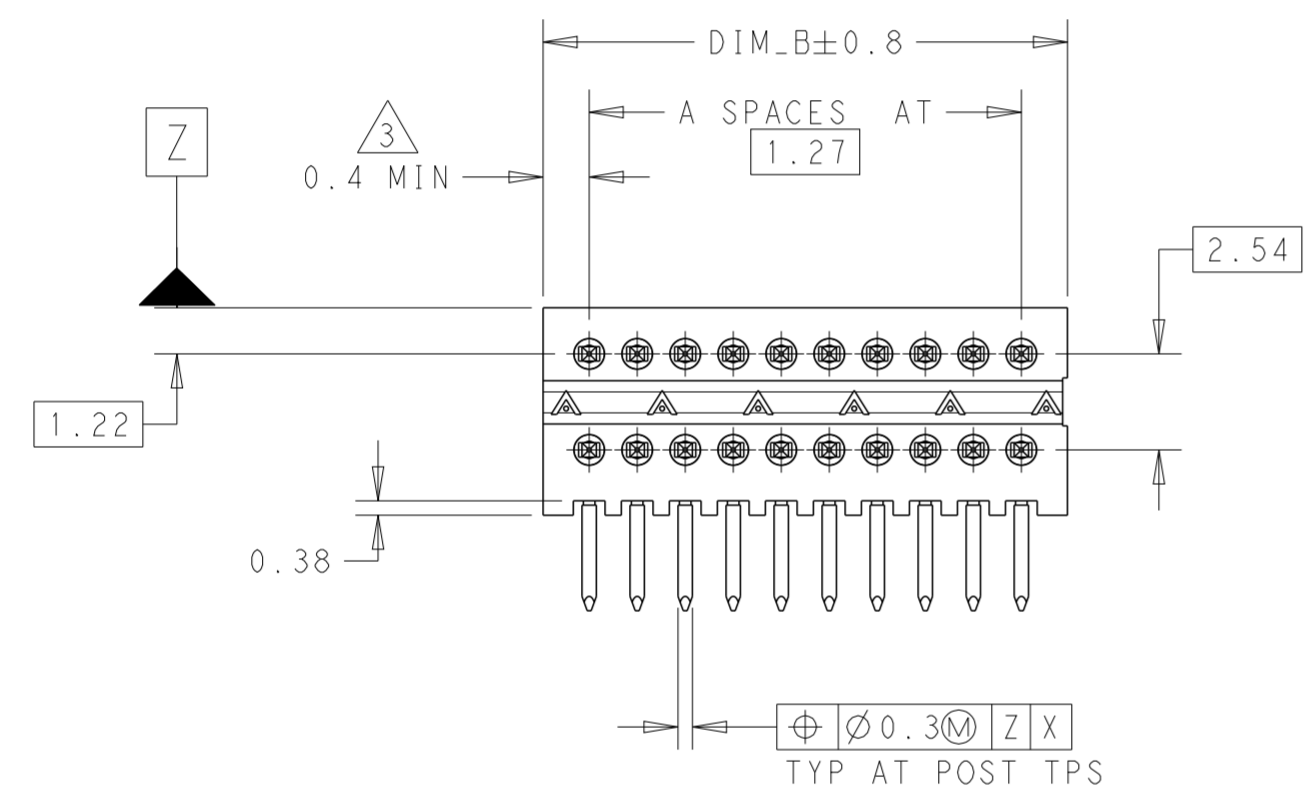

THIS DRAWING IS A CONTROLLED DOCUMENT.		DWN G. RAMESH 09NOV2017	TE Connectivity		
DIMENSIONS: mm		CHK J. OLSON 09NOV2017			
TOLERANCES UNLESS OTHERWISE SPECIFIED:		APVD J. OLSON 09NOV2017	NAME HEADER ASSEMBLY, RIGHT ANGLE, UNSHROUDED, DOUBLE ROW, AMPMODU System 50		
0 PLC ± 1 PLC ±0.3 2 PLC ±0.13 3 PLC ± 4 PLC ±		PRODUCT SPEC 108-1093	SIZE 114-20531		
ANGLES FINISH SEE TABLE		APPLICATION SPEC 114-20531	RESTRICTED TO		
MATERIAL 11		WEIGHT -	SCALE 5:1		
		CUSTOMER DRAWING	SHEET 1 OF 2		
			REV V		

THIS DRAWING IS UNPUBLISHED. RELEASED FOR PUBLICATION 20  
 © COPYRIGHT 20 BY - ALL RIGHTS RESERVED.

REVISIONS				
P	LTR	DESCRIPTION	DATE	APVD
-		SEE SHEET 1	-	-

7	63.88	49	100	8-104118-7	
	51.18	39	80	8-104118-6	
	46.10	35	72	8-104118-5	
	38.48	29	60	8-104118-4	
	28.32	21	44	8-104118-3	
	25.78	19	40	8-104118-2	
	21.97	16	34	8-104118-1	
	19.43	14	30	8-104118-0	
	16.89	12	26	7-104118-9	
	15.62	11	24	7-104118-8	
	13.08	9	20	7-104118-7	
	10.54	7	16	7-104118-6	
	9.27	6	14	7-104118-5	
	8.00	5	12	7-104118-4	
	6.73	4	10	7-104118-3	
	5.46	3	8	7-104118-2	
	32.13	24	50	7-104118-1	
	4	63.88	49	100	6-104118-7
		51.18	39	80	6-104118-6
		46.10	35	72	6-104118-5
38.48		29	60	6-104118-4	
28.32		21	44	6-104118-3	
25.78		19	40	6-104118-2	
21.97		16	34	6-104118-1	
19.43		14	30	6-104118-0	
16.89		12	26	5-104118-9	
15.62		11	24	5-104118-8	
13.08		9	20	5-104118-7	
10.54		7	16	5-104118-6	
9.27		6	14	5-104118-5	
8.00		5	12	5-104118-4	
6.73		4	10	5-104118-3	
5.46		3	8	5-104118-2	
32.13		24	50	5-104118-1	
FINISH		DIM_B	A SPACES	NO OF POSN	PART NUMBER

6	63.88	49	100	3-104118-7	
	51.18	39	80	3-104118-6	
	46.10	35	72	3-104118-5	
	38.48	29	60	3-104118-4	
	28.32	21	44	3-104118-3	
	25.78	19	40	3-104118-2	
	21.97	16	34	3-104118-1	
	19.43	14	30	3-104118-0	
	16.89	12	26	2-104118-9	
	15.62	11	24	2-104118-8	
	13.08	9	20	2-104118-7	
	10.54	7	16	2-104118-6	
	9.27	6	14	2-104118-5	
	8.00	5	12	2-104118-4	
	6.73	4	10	2-104118-3	
	5.46	3	8	2-104118-2	
	32.13	24	50	2-104118-1	
	1	63.88	49	100	1-104118-7
		51.18	39	80	1-104118-6
		46.10	35	72	1-104118-5
38.48		29	60	1-104118-4	
28.32		21	44	1-104118-3	
25.78		19	40	1-104118-2	
21.97		16	34	1-104118-1	
19.43		14	30	1-104118-0	
16.89		12	26	104118-9	
15.62		11	24	104118-8	
13.08		9	20	104118-7	
10.54		7	16	104118-6	
9.27		6	14	104118-5	
8.00		5	12	104118-4	
6.73		4	10	104118-3	
5.46		3	8	104118-2	
32.13		24	50	104118-1	
FINISH		DIM_B	A SPACES	NO OF POSN	PART NUMBER

THIS DRAWING IS A CONTROLLED DOCUMENT.		DWN G. RAMESH 09NOV2017	 TE Connectivity
DIMENSIONS: mm		CHK J. OLSON 09NOV2017	
TOLERANCES UNLESS OTHERWISE SPECIFIED: 0 PLC ± 1 PLC ±0.3 2 PLC ±0.13 3 PLC ± 4 PLC ±		APVD J. OLSON 09NOV2017	
MATERIAL		PRODUCT SPEC 108-1093	NAME HEADER ASSEMBLY, RIGHT ANGLE, UNSHROUDED, DOUBLE ROW, AMPMODU System 50
FINISH SEE TABLE		APPLICATION SPEC 114-20531	SIZE A200779
		WEIGHT -	DRAWING NO C-104118
		CUSTOMER DRAWING	RESTRICTED TO
		SCALE 5:1	SHEET 2 OF 2
			REV V

Компания «Life Electronics» занимается поставками электронных компонентов импортного и отечественного производства от производителей и со складов крупных дистрибьюторов Европы, Америки и Азии.

С конца 2013 года компания активно расширяет линейку поставок компонентов по направлению коаксиальный кабель, кварцевые генераторы и конденсаторы (керамические, пленочные, электролитические), за счёт заключения дистрибьюторских договоров

Мы предлагаем:

- Конкурентоспособные цены и скидки постоянным клиентам.
- Специальные условия для постоянных клиентов.
- Подбор аналогов.
- Поставку компонентов в любых объемах, удовлетворяющих вашим потребностям.
- Приемлемые сроки поставки, возможна ускоренная поставка.
- Доставку товара в любую точку России и стран СНГ.
- Комплексную поставку.
- Работу по проектам и поставку образцов.
- Формирование склада под заказчика.
- Сертификаты соответствия на поставляемую продукцию (по желанию клиента).
- Тестирование поставляемой продукции.
- Поставку компонентов, требующих военную и космическую приемку.
- Входной контроль качества.
- Наличие сертификата ISO.

В составе нашей компании организован Конструкторский отдел, призванный помогать разработчикам, и инженерам.

Конструкторский отдел помогает осуществить:

- Регистрацию проекта у производителя компонентов.
- Техническую поддержку проекта.
- Защиту от снятия компонента с производства.
- Оценку стоимости проекта по компонентам.
- Изготовление тестовой платы монтаж и пусконаладочные работы.



Тел: +7 (812) 336 43 04 (многоканальный)

Email: [org@lifeelectronics.ru](mailto:org@lifeelectronics.ru)