



**NPN 2N2218 – 2N2218A
2N2219 – 2N2219A**

SWITCHING SILICON TRANSISTORS

The 2N2218-A and 2N2219-A are NPN transistors mounted in TO-39 metal case . They are designed for high-speed switching applications and feature useful current gain over a wide range of collector current, low leakage currents and low saturation voltages. Compliance to RoHS

ABSOLUTE MAXIMUM RATINGS

Symbol	Ratings	Value		Unit
		2N2218 2N2219	2N2218 A 2N2219 A	
V _{CEO}	Collector-Emitter Voltage	30	40	V
V _{CBO}	Collector-Base Voltage	60	75	V
V _{EBO}	Emitter-Base Voltage	5	6	V
I _C	Collector Current	800		mA
P _D	Total Power Dissipation	T _{amb} = 25°	0.8	W
		T _{case} = 25°	3	
T _J	Junction Temperature	175		°C
T _{Stg}	Storage Temperature range	-65 to +200		°C

THERMAL CHARACTERISTICS

Symbol	Ratings	Value	Unit
R _{thJ-a}	Thermal Resistance, Junction to ambient in free air	50	°C/W
R _{thJ-c}	Thermal Resistance, Junction to case	187.5	°C/W

NPN 2N2218 – 2N2218A 2N2219 – 2N2219A

ELECTRICAL CHARACTERISTICS

TC=25°C unless otherwise noted

Symbol	Ratings	Test Condition(s)		Min	Typ	Max	Unit	
I_{CBO}	Collector Cutoff Current	$V_{CB}= 50\text{ V}$ $I_E= 0$	$T_j= 25^\circ\text{C}$	2N2218-2N2219	-	-	10	nA
			$T_j= 150^\circ\text{C}$	2N2218-2N2219	-	-	10	μA
		$V_{CB}= 60\text{ V}$ $I_E= 0$	$T_j= 25^\circ\text{C}$	2N2218A-2N2219A	-	-	10	nA
			$T_j= 150^\circ\text{C}$	2N2218A-2N2219A	-	-	10	μA
I_{EBO}	Emitter Cutoff Current	$V_{BE}= 3.0\text{ V}, I_C=0$		-	-	10	nA	
		2N2218-2N2219	2N2218A-2N2219A					
I_{CEX}	Collector Cutoff Current	$V_{CE}= 60\text{ V}, -V_{BE}= 3\text{V}$		-	-	10	nA	
V_{CEO}	Collector Emitter Breakdown Voltage (*)	$I_C= 10\text{ mA}, I_B= 0$		2N2218-2N2219	30	-	-	V
				2N2218A-2N2219A	40	-	-	
V_{CBO}	Collector Base Breakdown Voltage	$I_C= 10\text{ }\mu\text{A}, I_E= 0$		2N2218-2N2219	60	-	-	V
				2N2218A-2N2219A	75	-	-	
V_{EBO}	Emitter Base Breakdown Voltage	$I_E= 10\text{ }\mu\text{A}, I_C= 0$		2N2218-2N2219	5	-	-	V
				2N2218A-2N2219A	6	-	-	
h_{FE}	DC Current Gain (*)	$I_C=0.1\text{ mA}, V_{CE}=10\text{ V}$		2N2218-2N2218A	20	-	-	-
				2N2219-2N2219A	35	-	-	
		$I_C=1\text{ mA}, V_{CE}=10\text{ V}$		2N2218-2N2218A	25	-	-	
				2N2219-2N2219A	50	-	-	
		$I_C=10\text{ mA}, V_{CE}=10\text{ V}$		2N2218-2N2218A	35	-	-	
				2N2219-2N2219A	75	-	-	
		$I_C=10\text{ mA}, V_{CE}=10\text{ V}$ $T_{amb} = -55^\circ\text{C}$		2N2218A	15	-	-	
				2N2219A	35	-	-	
		$I_C=150\text{ mA}, V_{CE}=1\text{ V}$		2N2218-2N2218A	20	-	-	
				2N2219-2N2219A	50	-	-	
		$I_C=150\text{ mA}, V_{CE}=10\text{ V}$		2N2218-2N2218A	40	-	120	
				2N2219-2N2219A	100	-	300	
$I_C=500\text{ mA}, V_{CE}=10\text{ V}$		2N2218	20	-	-			
		2N2218A	25	-	-			
		2N2219	30	-	-			
		2N2219A	40	-	-			

NPN 2N2218 – 2N2218A 2N2219 – 2N2219A

ELECTRICAL CHARACTERISTICS

TC=25°C unless otherwise noted

Symbol	Ratings	Test Condition(s)		Min	Typ	Mx	Unit
$V_{CE(SAT)}$	Collector-Emitter saturation Voltage (*)	$I_C=150\text{ mA}, I_B=15\text{ mA}$	2N2218-2N2219	-	-	0.4	V
			2N2218A-2N2219A	-	-	0.3	
		$I_C=500\text{ mA}, I_B=50\text{ mA}$	2N2218-2N2219	-	-	1.6	
			2N2218A-2N2219A	-	-	1	
$V_{CE(SAT)}$	Collector-Emitter saturation Voltage (*)	$I_C=150\text{ mA}, I_B=15\text{ mA}$	2N2218-2N2219	-	-	1.3	V
			2N2218A-2N2219A	0.6	-	1.2	
		$I_C=500\text{ mA}, I_B=50\text{ mA}$	2N2218-2N2219	-	-	2.6	
			2N2218A-2N2219A	-	-	2	
f_T	Transition frequency	$I_C=20\text{ mA}, V_{CE}=20\text{ V}$ $f=100\text{ MHz}$	2N2218-2N2218A 2N2219	250	-	-	MHz
			2N2219A	300	-	-	
h_{fe}	Small signal current gain	$I_C=1\text{ mA}, V_{CE}=10\text{ V}$ $f=1\text{ kHz}$	2N2218A	30	-	150	-
			2N2219A	50	-	300	
		$I_C=10\text{ mA}, V_{CE}=10\text{ V}$ $f=1\text{ kHz}$	2N2218A	50	-	300	
			2N2219A	75	-	375	
t_d	Delay time	$I_C=150\text{ mA}, I_B=15\text{ mA}$ $-V_{BB}=0.5\text{ V}, V_{CC}=30\text{ V}$	2N2218A 2N2219A	-	-	10	ns
t_r	Rise time	$I_C=150\text{ mA}, I_B=15\text{ mA}$ $-V_{BB}=0.5\text{ V}, V_{CC}=30\text{ V}$	2N2218A 2N2219A	-	-	25	ns
t_s	Storage time	$I_C=150\text{ mA}, V_{CC}=30\text{ V}$ $I_{B1} = -I_{B2} = 15\text{ mA}$	2N2218A 2N2219A	-	-	225	ns
t_f	Fall time	$I_C=150\text{ mA}, V_{CC}=30\text{ V}$ $I_{B1} = -I_{B2} = 15\text{ mA}$	2N2218A 2N2219A	-	-	60	ns
r_b, C_c	Feedback time constant	$I_C=20\text{ mA}, V_{CE}=20\text{ V}$ $f=31.8\text{ MHz}$	2N2218A 2N2219A	-	-	150	ps

(*) Pulse conditions : $t_p < 300\text{ }\mu\text{s}, \delta = 2\%$

**NPN 2N2218 – 2N2218A
2N2219 – 2N2219A**

MECHANICAL DATA CASE TO-39

DIMENSIONS (mm)		
	min	max
A	8.50	9.39
B	7.74	8.50
C	6.09	6.60
D	0.40	0.53
E	-	0.88
F	2.41	2.66
G	4.82	5.33
H	0.71	0.86
J	0.73	1.02
K	12.70	-
L	42°	48°

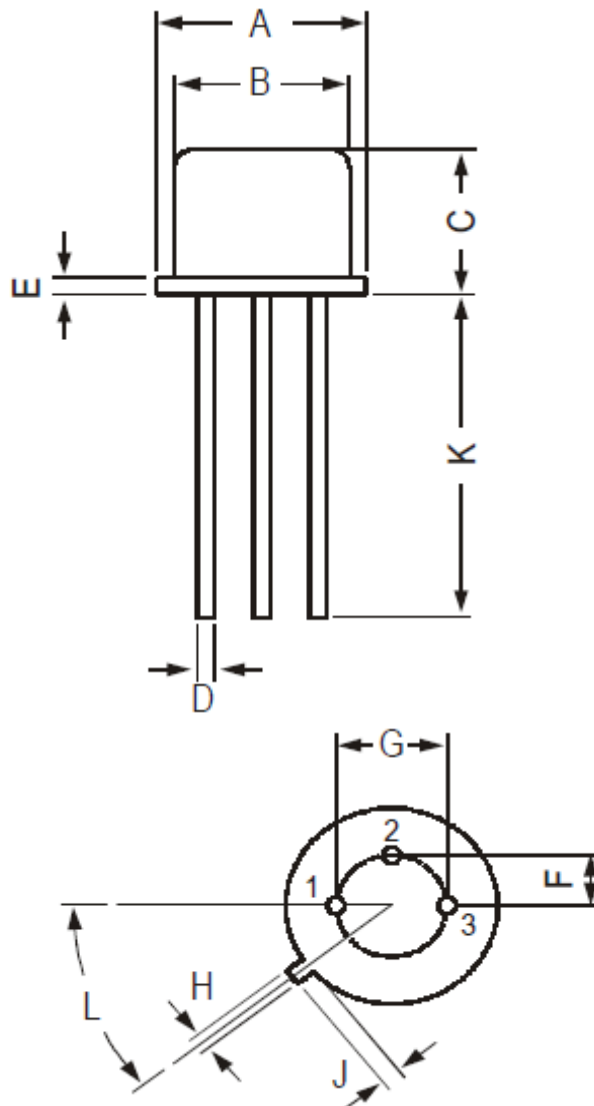

Pin 1 :	Emitter
Pin 2 :	Base
Pin 3 :	Collector
Case :	Collector

Revised August 2012

Information furnished is believed to be accurate and reliable. However, Comset Semiconductors assumes no responsibility for the consequences of use of such information nor for any infringement of patents or other rights of third parties which may result from its use. Data are subject to change without notice. Comset Semiconductors makes no warranty, representation or guarantee regarding the suitability of its products for any particular purpose, nor does Comset Semiconductors assume any liability arising out of the application or use of any product and specifically disclaims any and all liability, including without limitation consequential or incidental damages. Comset Semiconductors' products are not authorized for use as critical components in life support devices or systems.

Компания «Life Electronics» занимается поставками электронных компонентов импортного и отечественного производства от производителей и со складов крупных дистрибьюторов Европы, Америки и Азии.

С конца 2013 года компания активно расширяет линейку поставок компонентов по направлению коаксиальный кабель, кварцевые генераторы и конденсаторы (керамические, пленочные, электролитические), за счёт заключения дистрибьюторских договоров

Мы предлагаем:

- Конкурентоспособные цены и скидки постоянным клиентам.
- Специальные условия для постоянных клиентов.
- Подбор аналогов.
- Поставку компонентов в любых объемах, удовлетворяющих вашим потребностям.
- Приемлемые сроки поставки, возможна ускоренная поставка.
- Доставку товара в любую точку России и стран СНГ.
- Комплексную поставку.
- Работу по проектам и поставку образцов.
- Формирование склада под заказчика.
- Сертификаты соответствия на поставляемую продукцию (по желанию клиента).
- Тестирование поставляемой продукции.
- Поставку компонентов, требующих военную и космическую приемку.
- Входной контроль качества.
- Наличие сертификата ISO.

В составе нашей компании организован Конструкторский отдел, призванный помогать разработчикам, и инженерам.

Конструкторский отдел помогает осуществить:

- Регистрацию проекта у производителя компонентов.
- Техническую поддержку проекта.
- Защиту от снятия компонента с производства.
- Оценку стоимости проекта по компонентам.
- Изготовление тестовой платы монтаж и пусконаладочные работы.



Тел: +7 (812) 336 43 04 (многоканальный)

Email: org@lifeelectronics.ru