

N-channel 650 V, 0.335 Ω typ., 10 A MDmesh™ M5 Power MOSFET in a PowerFLAT™ 5x6 HV package

Datasheet - production data

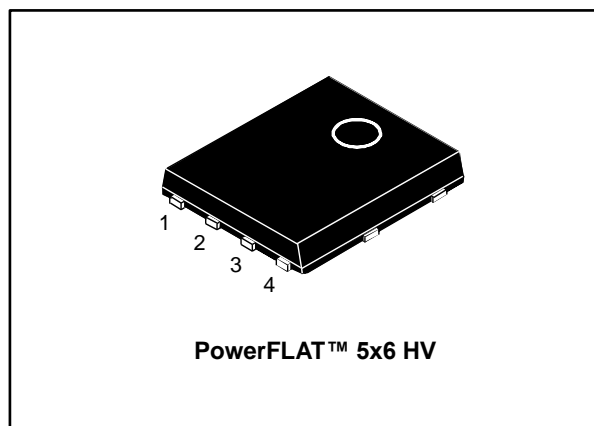
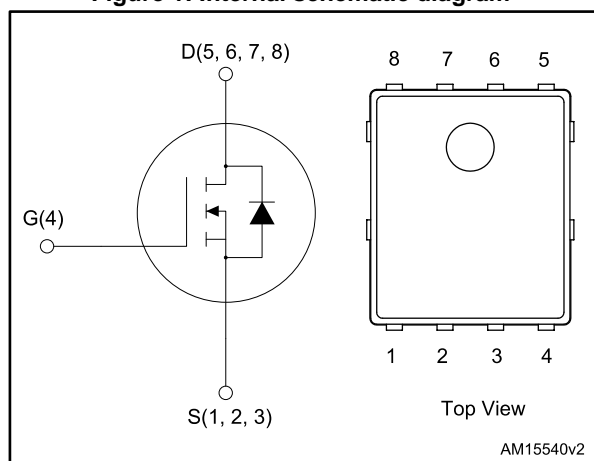

Figure 1: Internal schematic diagram



Features

Order code	V _{DS} @ T _J max.	R _{DS(on)} max	I _D
STL15N65M5	710 V	0.375 Ω	10 A

- Extremely low R_{DS(on)}
- Low gate charge and input capacitance
- Excellent switching performance
- 100% avalanche tested

Applications

- Switching applications

Description

This device is an N-channel Power MOSFET based on the MDmesh™ M5 innovative vertical process technology combined with the well-known PowerMESH™ horizontal layout. The resulting product offers extremely low on-resistance, making it particularly suitable for applications requiring high power and superior efficiency.

Table 1: Device summary

Order code	Marking	Package	Packing
STL15N65M5	15N65M5	PowerFLAT™ 5x6 HV	Tape and reel

Contents

1	Electrical ratings	3
2	Electrical characteristics	4
	2.1 Electrical characteristics (curves)	6
3	Test circuits	9
4	Package information	10
	4.1 Power Flat™ 5x6 HV package information	11
	4.2 Power Flat™ 5x6 HV packing information.....	13
5	Revision history	15

1 Electrical ratings

Table 2: Absolute maximum ratings

Symbol	Parameter	Value	Unit
V _{DS}	Drain-source voltage	650	V
V _{GS}	Gate-source voltage	± 25	V
I _D	Drain current (continuous) at T _C = 25 °C	10	A
I _D	Drain current (continuous) at T _C = 100 °C	5	A
I _{DM} ⁽¹⁾	Drain current (pulsed)	40	A
P _{TOT}	Total dissipation at T _C = 25 °C	52	W
I _{AR}	Avalanche current, repetitive or not-repetitive (pulse width limited by T _j max)	2.5	A
E _{AS}	Single pulse avalanche energy (starting T _j = 25 °C, I _D = I _{AR} , V _{DD} = 50 V)	160	mJ
dv/dt ⁽²⁾	Peak diode recovery voltage slope	15	V/ns
T _{stg}	Storage temperature range	- 55 to 150	°C
T _j	Operating junction temperature range		°C

Notes:

⁽¹⁾Pulse width limited by safe operating area.

⁽²⁾I_{SD} ≤ 10 A, di/dt ≤ 400 A/μs, V_{DS(peak)} ≤ V_{(BR)DSS}, V_{DD} = 400 V.

Table 3: Thermal data

Symbol	Parameter	Value	Unit
R _{thj-case}	Thermal resistance junction-case	2.4	°C/W
R _{thj-pcb} ⁽¹⁾	Thermal resistance junction-pcb	59	°C/W

Notes:

⁽¹⁾When mounted on 1inch² FR-4 board, 2 oz Cu.

2 Electrical characteristics

($T_C = 25\text{ °C}$ unless otherwise specified)

Table 4: On /off states

Symbol	Parameter	Test conditions	Min.	Typ.	Max.	Unit
$V_{(BR)DSS}$	Drain-source breakdown voltage	$I_D = 1\text{ mA}$, $V_{GS} = 0\text{ V}$	650			V
I_{DSS}	Zero gate voltage drain current	$V_{DS} = 650\text{ V}$			1	μA
		$V_{DS} = 650\text{ V}$, $T_C = 125\text{ °C}$ ⁽¹⁾ , $V_{GS} = 0\text{ V}$			100	μA
I_{GSS}	Gate-body leakage current	$V_{GS} = \pm 25\text{ V}$, $V_{DS} = 0$			± 100	nA
$V_{GS(th)}$	Gate threshold voltage	$V_{DS} = V_{GS}$, $I_D = 250\text{ }\mu\text{A}$	3	4	5	V
$R_{DS(on)}$	Static drain-source on- resistance	$V_{GS} = 10\text{ V}$, $I_D = 5\text{ A}$		0.335	0.375	Ω

Notes:

⁽¹⁾Defined by design, not subject to production test.

Table 5: Dynamic

Symbol	Parameter	Test conditions	Min.	Typ.	Max.	Unit
C_{iss}	Input capacitance	$V_{DS} = 100\text{ V}$, $f = 1\text{ MHz}$, $V_{GS} = 0\text{ V}$	-	816	-	pF
C_{oss}	Output capacitance		-	23	-	pF
C_{rss}	Reverse transfer capacitance		-	2.6	-	pF
$C_{o(tr)}$ ⁽¹⁾	Equivalent capacitance time related	$V_{DS} = 0\text{ to }520\text{ V}$, $V_{GS} = 0\text{ V}$	-	70	-	pF
$C_{o(er)}$ ⁽²⁾	Equivalent capacitance energy related		-	21	-	pF
R_G	Intrinsic gate resistance	$f = 1\text{ MHz}$ open drain	-	5	-	Ω
Q_g	Total gate charge	$V_{DD} = 520\text{ V}$, $I_D = 5.5\text{ A}$, $V_{GS} = 10\text{ V}$ (see Figure 16: "Test circuit for gate charge behavior")	-	22	-	nC
Q_{gs}	Gate-source charge		-	5.5	-	nC
Q_{gd}	Gate-drain charge		-	11	-	nC

Notes:

⁽¹⁾ C_{oss} eq. time related is defined as a constant equivalent capacitance giving the same charging time as C_{oss} when V_{DS} increases from 0 to 80 % V_{DSS} .

⁽²⁾ C_{oss} eq. energy related is defined as a constant equivalent capacitance giving the same stored energy as C_{oss} when V_{DS} increases from 0 to 80 % V_{DSS} .

Table 6: Switching times

Symbol	Parameter	Test conditions	Min.	Typ.	Max	Unit
$t_{d(V)}$	Voltage delay time	$V_{DD} = 400 \text{ V}$, $I_D = 7 \text{ A}$, $R_G = 4.7 \text{ } \Omega$, $V_{GS} = 10 \text{ V}$ (see Figure 17: "Test circuit for inductive load switching and diode recovery times" and Figure 20: "Switching time waveform")	-	30	-	ns
$t_{r(V)}$	Voltage rise time		-	8	-	ns
$t_{f(I)}$	Current fall time		-	11	-	ns
$t_{c(off)}$	Crossing time		-	12.5	-	ns

Table 7: Source drain diode

Symbol	Parameter	Test conditions	Min.	Typ.	Max.	Unit
I_{SD}	Source-drain current		-		10	A
$I_{SDM}^{(1)}$	Source-drain current (pulsed)		-		40	A
$V_{SD}^{(2)}$	Forward on voltage	$I_{SD} = 10 \text{ A}$, $V_{GS} = 0$	-		1.5	V
t_{rr}	Reverse recovery time	$I_{SD} = 10 \text{ A}$, $di/dt = 100 \text{ A}/\mu\text{s}$ $V_{DD} = 100 \text{ V}$ (see Figure 17: "Test circuit for inductive load switching and diode recovery times")	-	244		ns
Q_{rr}	Reverse recovery charge		-	2.35		μC
I_{RRM}	Reverse recovery current		-	19.2		A
t_{rr}	Reverse recovery time	$I_{SD} = 10 \text{ A}$, $di/dt = 100 \text{ A}/\mu\text{s}$ $V_{DD} = 100 \text{ V}$, $T_j = 150 \text{ }^\circ\text{C}$ (see Figure 17: "Test circuit for inductive load switching and diode recovery times")	-	308		ns
Q_{rr}	Reverse recovery charge		-	2.93		μC
I_{RRM}	Reverse recovery current		-	19		A

Notes:

(1)Pulse width limited by safe operating area.

(2)Pulsed: pulse duration = 300 μs , duty cycle 1.5 %.

2.1 Electrical characteristics (curves)

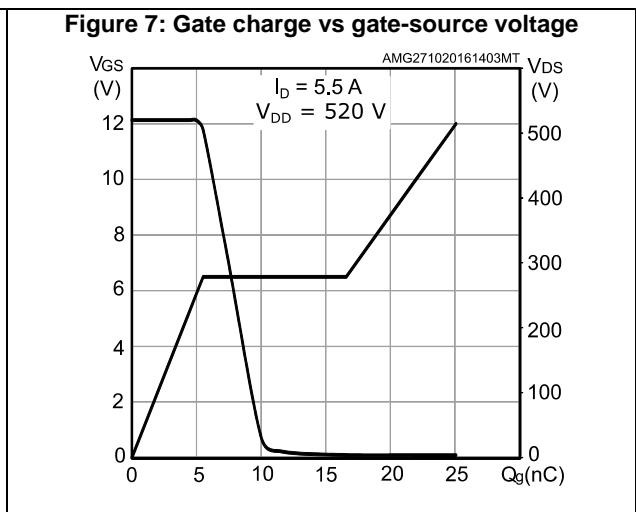
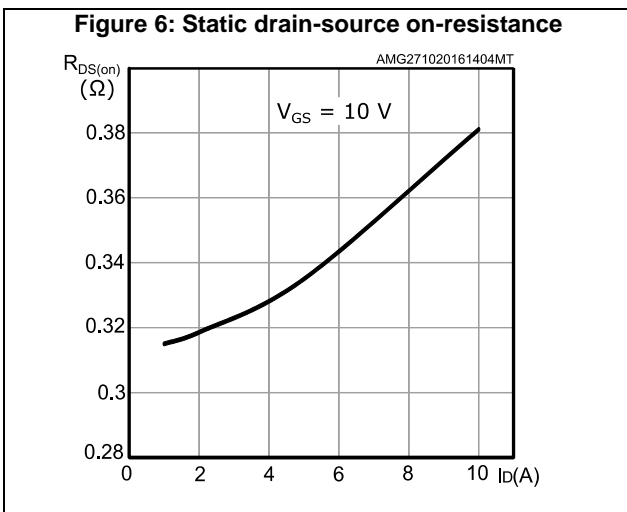
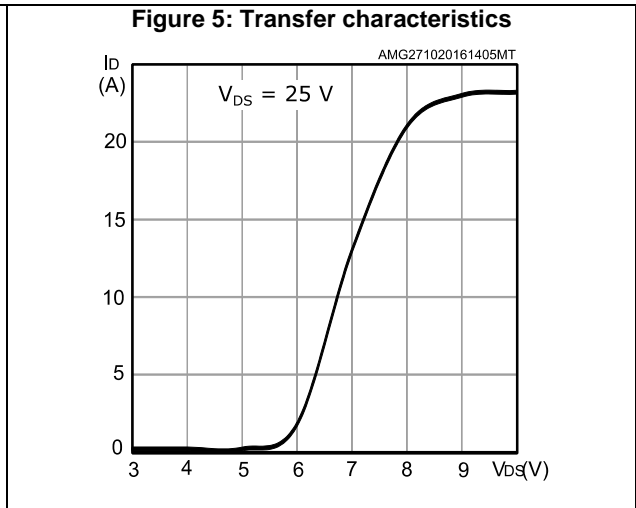
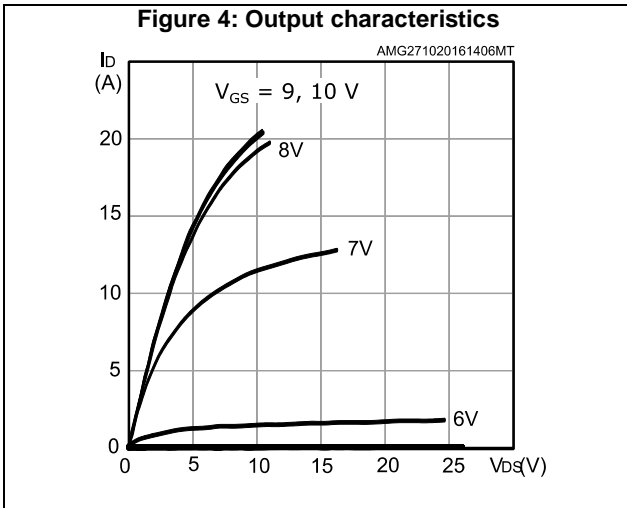
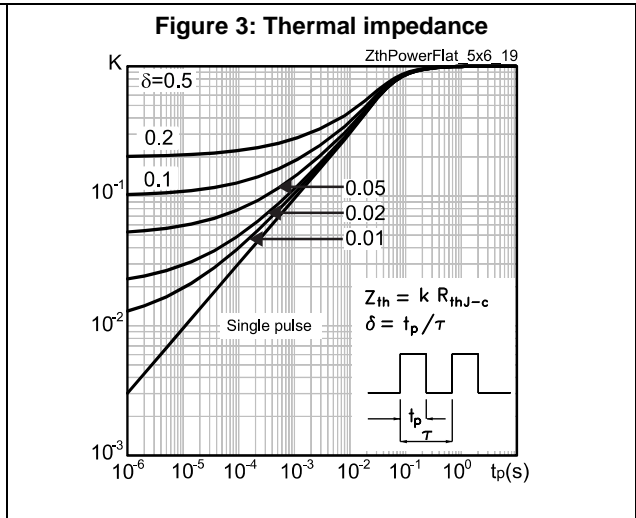
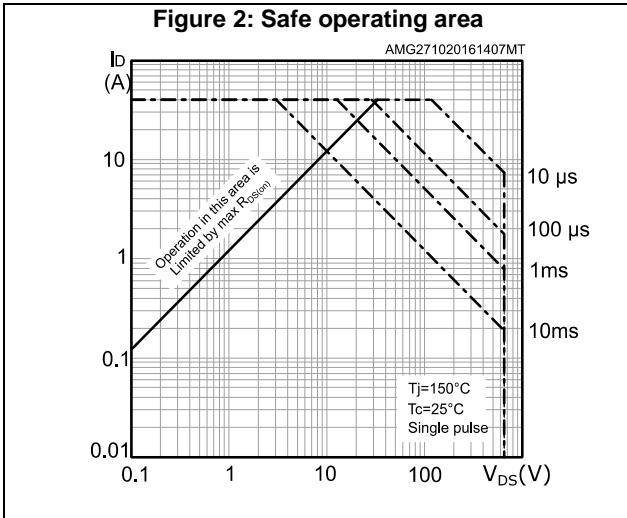

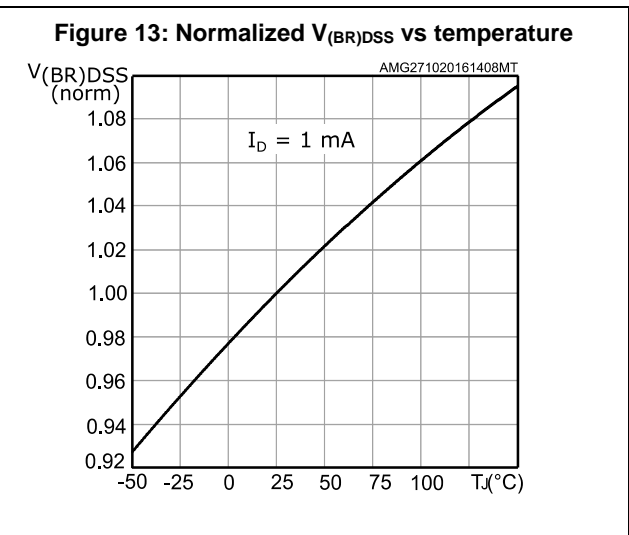
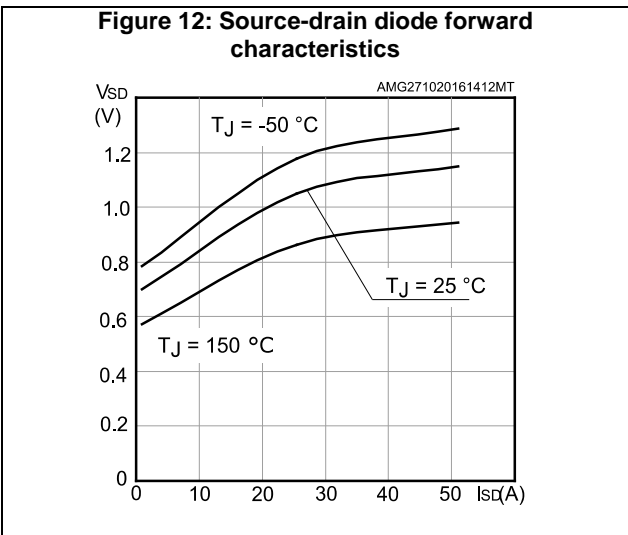
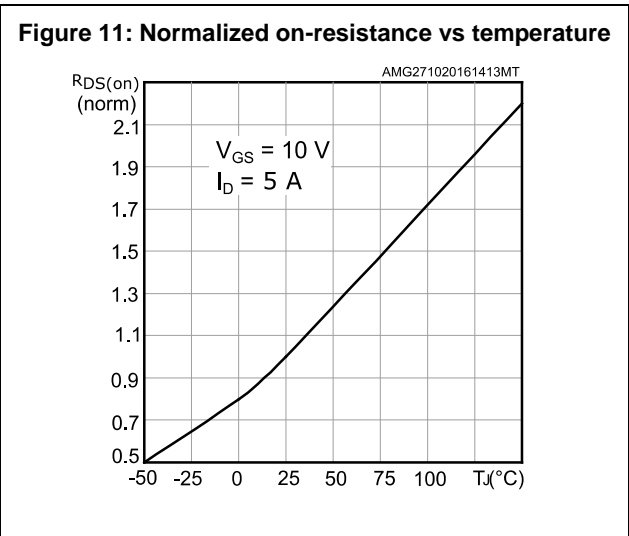
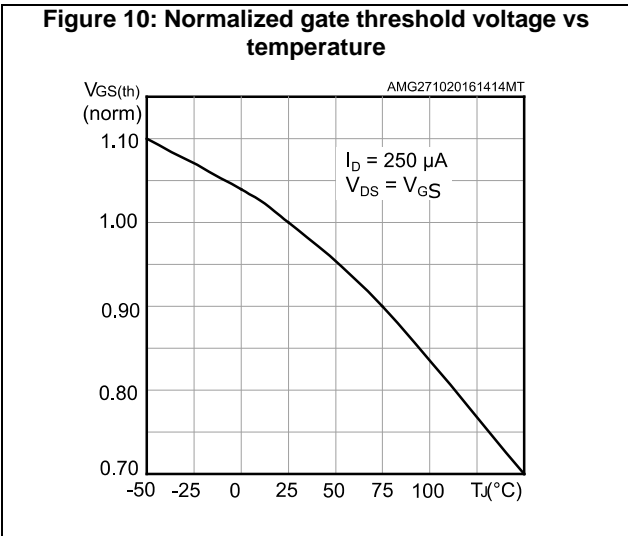
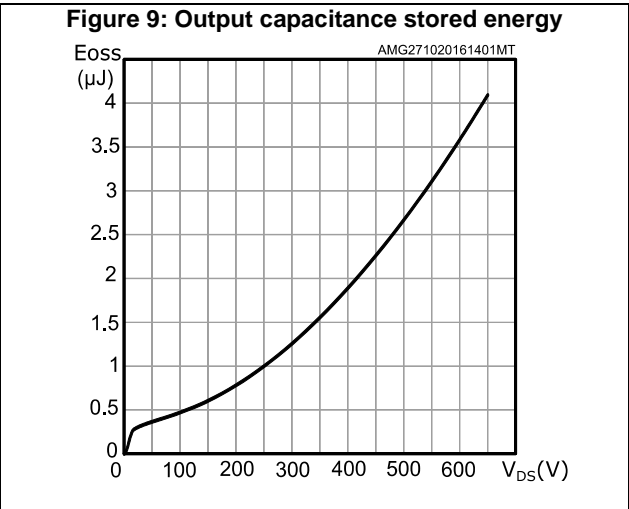
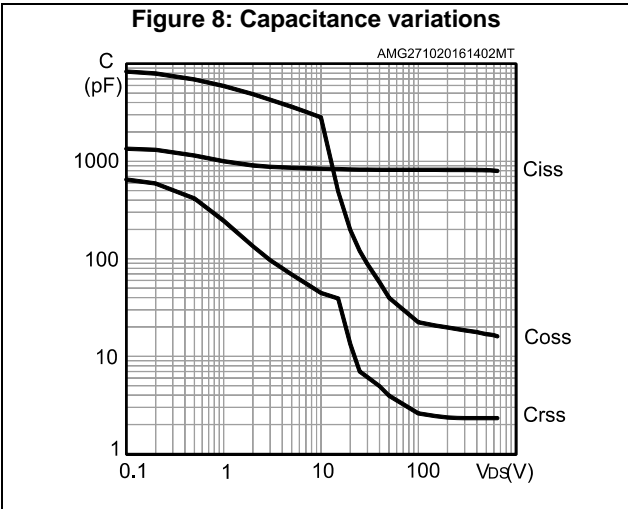
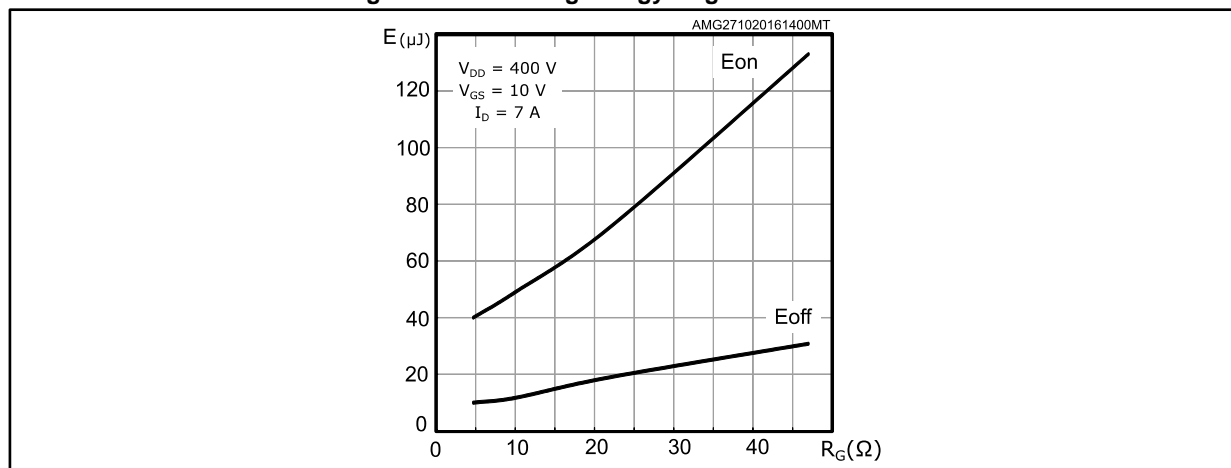

Figure 14: Switching energy vs gate resistance⁽¹⁾



Notes:

⁽¹⁾ E_{on} including reverse recovery of a SiC diode.

3 Test circuits

Figure 15: Test circuit for resistive load switching times

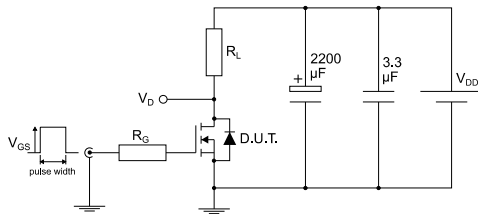

AM01468v1

Figure 16: Test circuit for gate charge behavior

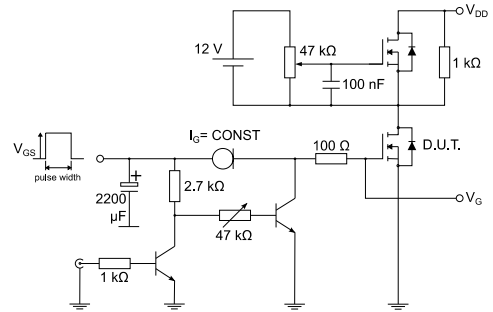

AM01469v1

Figure 17: Test circuit for inductive load switching and diode recovery times

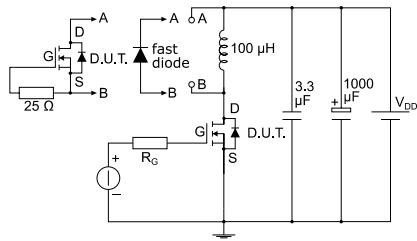

AM01470v1

Figure 18: Unclamped inductive load test circuit

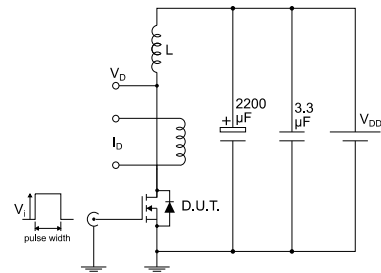

AM01471v1

Figure 19: Unclamped inductive waveform

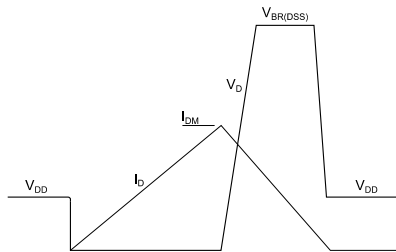

AM01472v1

Figure 20: Switching time waveform

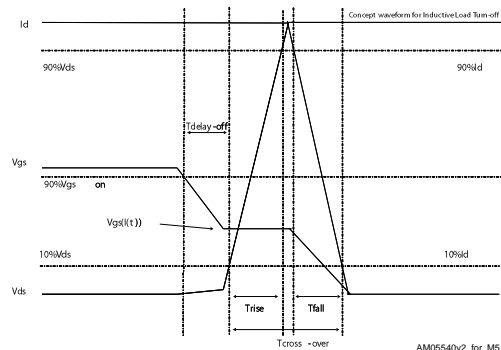

AM05540v2_for_M5

4 Package information

In order to meet environmental requirements, ST offers these devices in different grades of ECOPACK® packages, depending on their level of environmental compliance. ECOPACK® specifications, grade definitions and product status are available at: www.st.com. ECOPACK® is an ST trademark.

4.1 Power Flat™ 5x6 HV package information

Figure 21: PowerFLAT™ 5x6 HV package outline

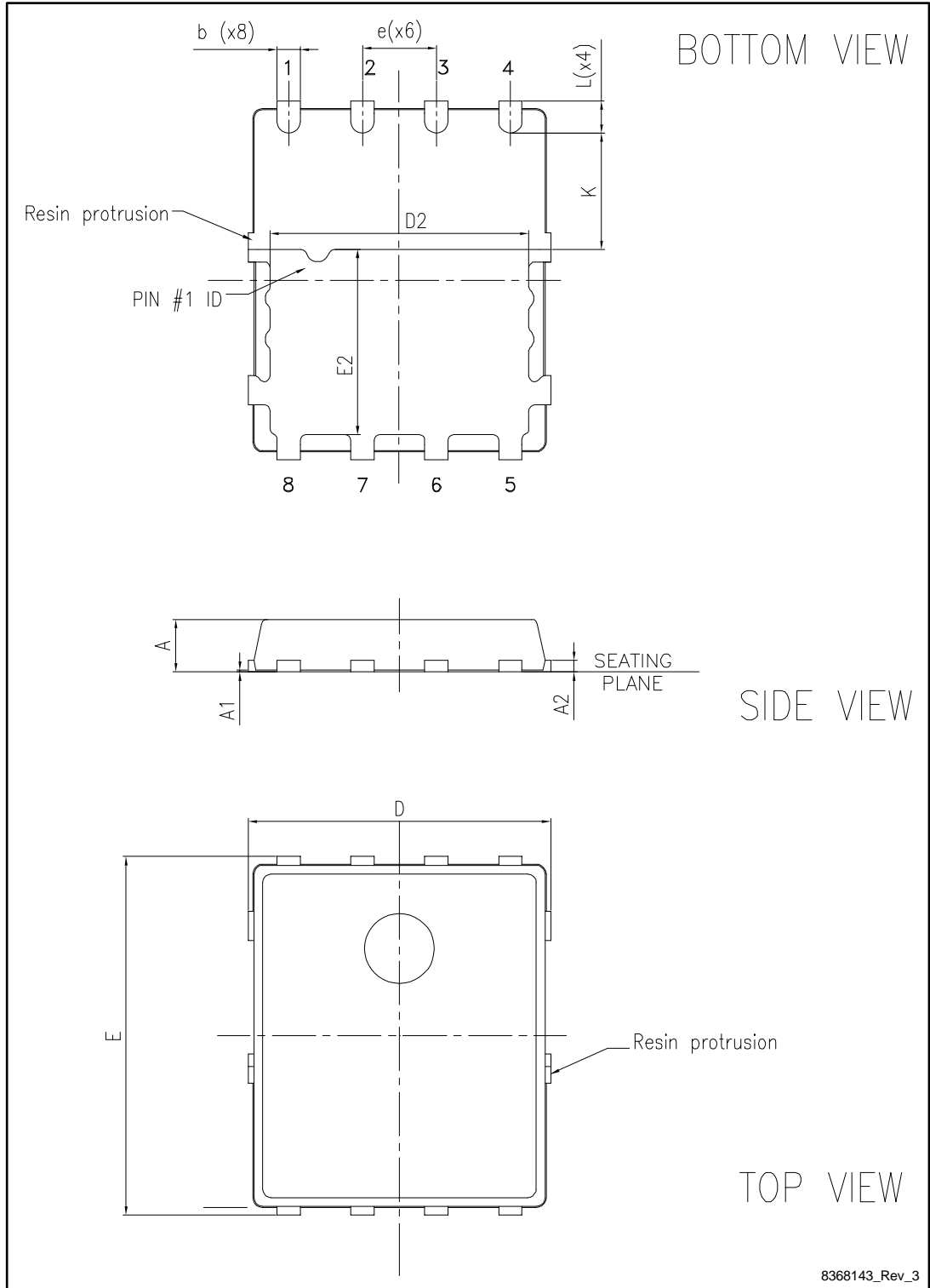
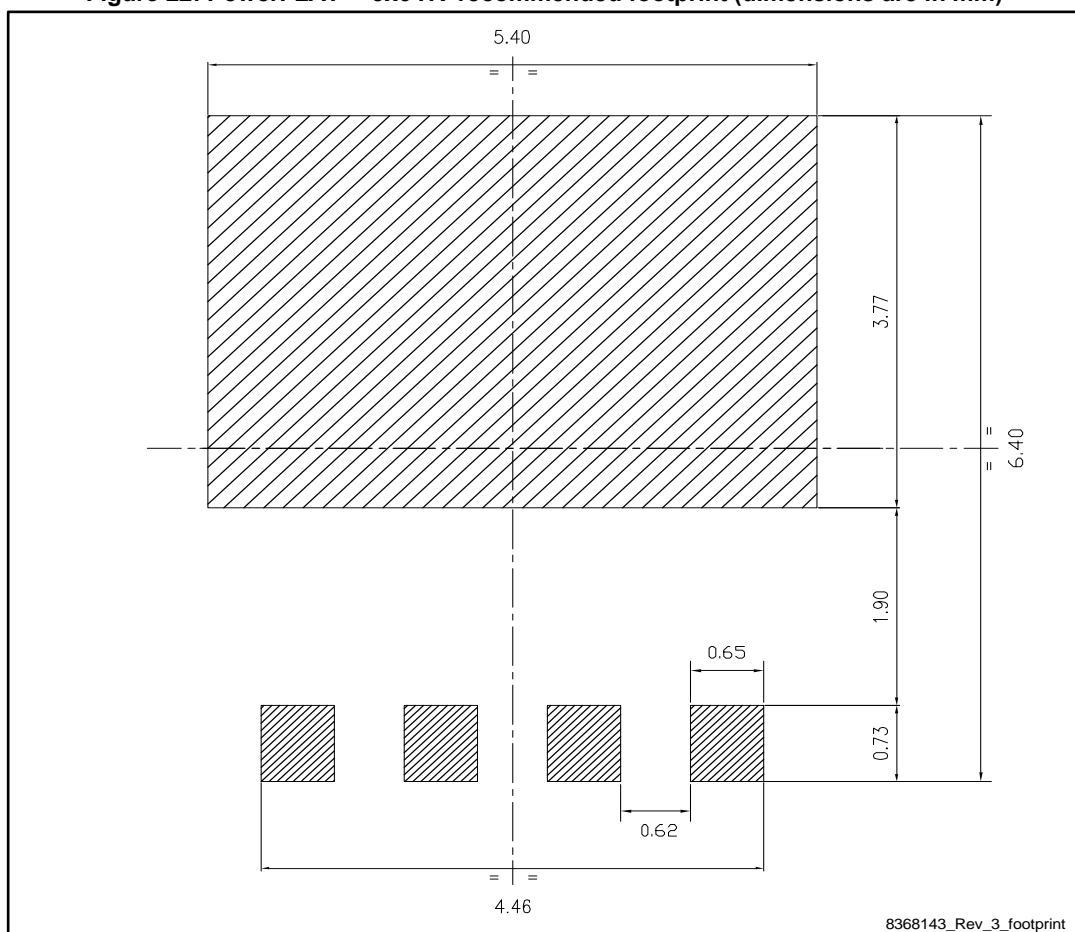

Table 8: PowerFLAT™ 5x6 HV mechanical data

Dim.	mm		
	Min.	Typ.	Max.
A	0.80		1.00
A1	0.02		0.05
A2		0.25	
b	0.30		0.50
D	5.10	5.20	5.30
E	6.05	6.15	6.25
E2	3.10	3.20	3.30
D2	4.30	4.40	4.50
e		1.27	
L	0.50	0.55	0.60
K	1.90	2.00	2.10

Figure 22: PowerFLAT™ 5x6 HV recommended footprint (dimensions are in mm)



4.2 Power Flat™ 5x6 HV packing information

Figure 23: PowerFLAT™ 5x6 tape (dimensions are in mm)

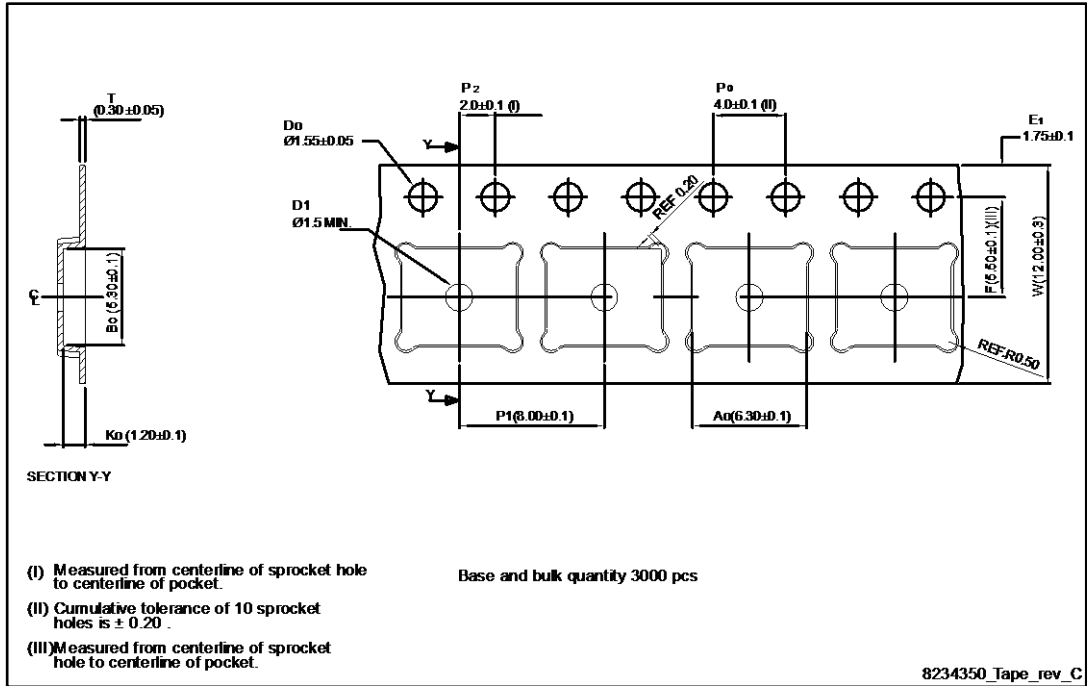

Figure 24: PowerFLAT™ 5x6 package orientation in carrier tape

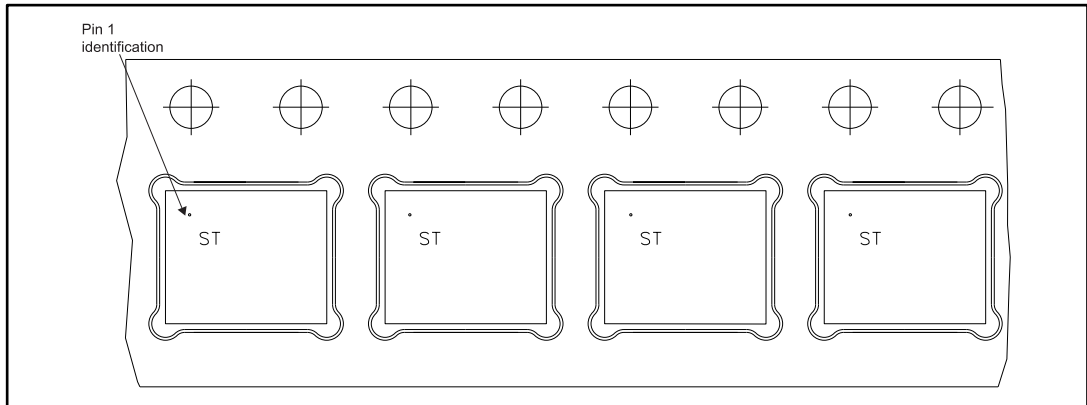
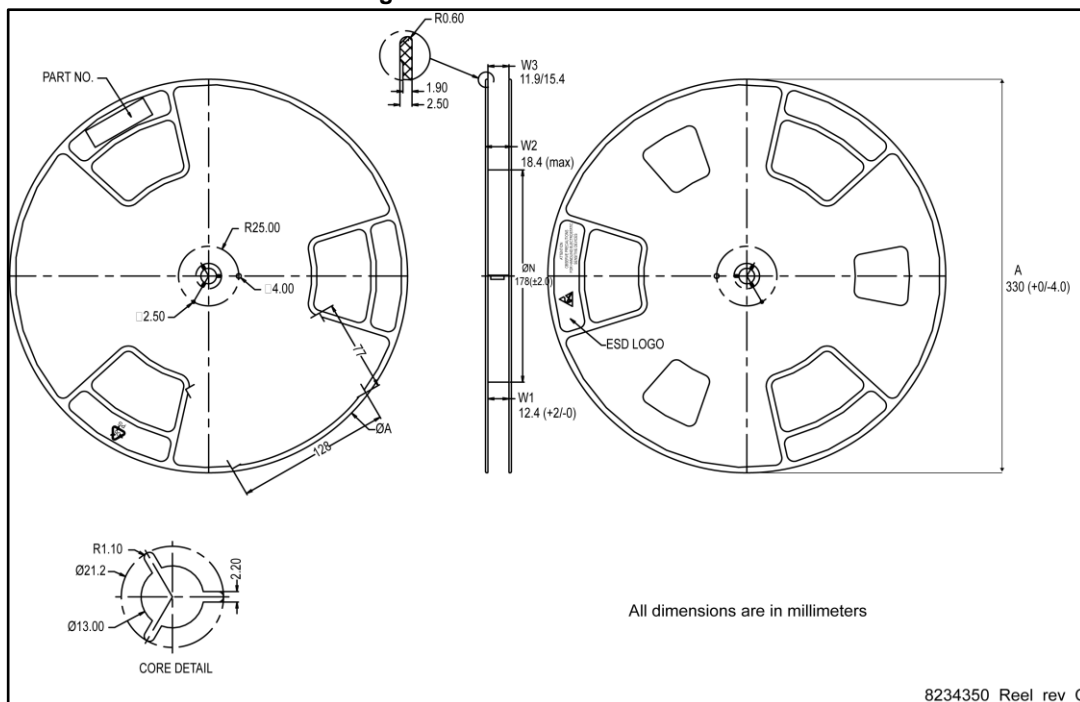

Figure 25: PowerFLAT™ 5x6 reel



5 Revision history

Table 9: Document revision history

Date	Revision	Changes
26-Jun-2013	1	First release
05-Dec-2016	2	Updated title, features and description in cover page. Updated <i>Figure 1: "Internal schematic diagram"</i> , <i>Table 2: "Absolute maximum ratings"</i> and <i>Section 4: "Package information"</i> . Minor text changes.

IMPORTANT NOTICE – PLEASE READ CAREFULLY

STMicroelectronics NV and its subsidiaries ("ST") reserve the right to make changes, corrections, enhancements, modifications, and improvements to ST products and/or to this document at any time without notice. Purchasers should obtain the latest relevant information on ST products before placing orders. ST products are sold pursuant to ST's terms and conditions of sale in place at the time of order acknowledgement.

Purchasers are solely responsible for the choice, selection, and use of ST products and ST assumes no liability for application assistance or the design of Purchasers' products.

No license, express or implied, to any intellectual property right is granted by ST herein.

Resale of ST products with provisions different from the information set forth herein shall void any warranty granted by ST for such product.

ST and the ST logo are trademarks of ST. All other product or service names are the property of their respective owners.

Information in this document supersedes and replaces information previously supplied in any prior versions of this document.

© 2016 STMicroelectronics – All rights reserved

Компания «Life Electronics» занимается поставками электронных компонентов импортного и отечественного производства от производителей и со складов крупных дистрибьюторов Европы, Америки и Азии.

С конца 2013 года компания активно расширяет линейку поставок компонентов по направлению коаксиальный кабель, кварцевые генераторы и конденсаторы (керамические, пленочные, электролитические), за счёт заключения дистрибьюторских договоров

Мы предлагаем:

- Конкурентоспособные цены и скидки постоянным клиентам.
- Специальные условия для постоянных клиентов.
- Подбор аналогов.
- Поставку компонентов в любых объемах, удовлетворяющих вашим потребностям.
- Приемлемые сроки поставки, возможна ускоренная поставка.
- Доставку товара в любую точку России и стран СНГ.
- Комплексную поставку.
- Работу по проектам и поставку образцов.
- Формирование склада под заказчика.
- Сертификаты соответствия на поставляемую продукцию (по желанию клиента).
- Тестирование поставляемой продукции.
- Поставку компонентов, требующих военную и космическую приемку.
- Входной контроль качества.
- Наличие сертификата ISO.

В составе нашей компании организован Конструкторский отдел, призванный помогать разработчикам, и инженерам.

Конструкторский отдел помогает осуществить:

- Регистрацию проекта у производителя компонентов.
- Техническую поддержку проекта.
- Защиту от снятия компонента с производства.
- Оценку стоимости проекта по компонентам.
- Изготовление тестовой платы монтаж и пусконаладочные работы.



Тел: +7 (812) 336 43 04 (многоканальный)

Email: org@lifeelectronics.ru