

## DESCRIPTION

The MP5408M integrates a monolithic, step-down, switch-mode converter with two USB current-limit switches and charging port identification circuitry for each port. The MP5408M achieves 6A of output current with excellent load and line regulation over a wide input-supply range.

The output of the USB switch is current-limited. Both USB ports support DCP schemes for battery charging specification (BC1.2), divider mode, 1.2V/1.2V mode and USB Type-C 5V@3A DFP mode, eliminating the need for outside user interaction.

Full protection features include hiccup current limiting, output over-voltage protection (OVP), and thermal shutdown.

The MP5408M requires a minimal number of readily available, standard, external components and is available in a QFN-26 (5mmx5mm) package.

## FEATURES

- EMI Reduction Technique
- Wide 6V to 36V Operating Input Voltage Range
- Selectable Output Voltage: 5.1V, 5.17V, and 5.3V
- 90mV Line Drop Compensation
- Accurate USB1/USB2 Output Current Limit
- 18mΩ/15mΩ Low  $R_{DS(ON)}$  Internal Buck Power MOSFETs
- 13mΩ/13mΩ Low  $R_{DS(ON)}$  Internal USB1/USB2 Power MOSFETs
- Frequency Adjustable (235kHz to 2.2MHz)
- Forced Continuous Conduction Mode (CCM) Operation
- Hiccup Current Limit for both Buck and USB
- Supports DCP Schemes for BC1.2, Divider Mode, and 1.2V/1.2V Mode
- Supports USB Type-C 5V @ 3A DFP Mode
- ±8kV HBM ESD Rating for USB, DP, and DM pins
- Available in a QFN-26 (5mmx5mm) Package

## APPLICATIONS

- USB Dedicated Charging Ports (DCP)
- USB Type-C 5V @ 3A DFP
- Automotive Cigarette Lighter Adapters
- Power Supply for Linear Chargers

All MPS parts are lead-free, halogen-free, and adhere to the RoHS directive. For MPS green status, please visit MPS website under Quality Assurance. "MPS" and "The Future of Analog IC Technology" are registered trademarks of Monolithic Power Systems, Inc.

## TYPICAL APPLICATION

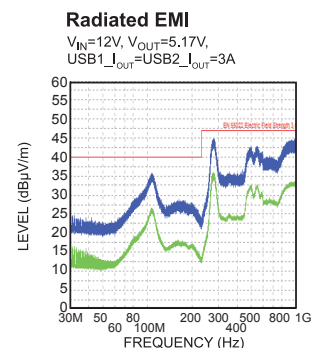
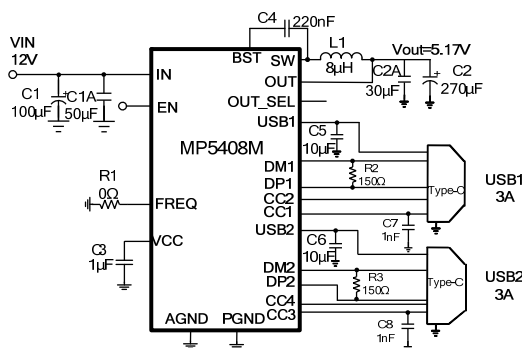

## ORDERING INFORMATION

Part Number*	Package	Top Marking
MP5408MGU	QFN-26 (5mmx5mm)	See Below

\* For Tape & Reel, add suffix -Z (e.g. MP5408MGU-Z)

## TOP MARKING

**MPSYYWW**

**MP5408M**

**LLLLLLL**

MPS: MPS prefix  
 YY: Year code  
 WW: Week code  
 MP5408M: Product code of MP5408MGU  
 LLLLLLL: Lot number

## PACKAGE REFERENCE

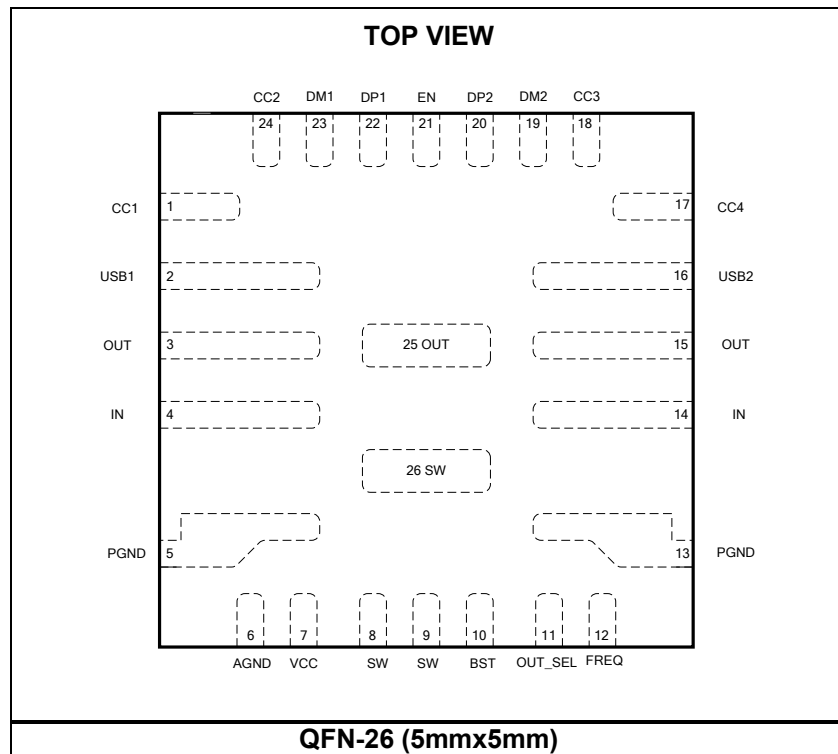

**ABSOLUTE MAXIMUM RATINGS** <sup>(1)</sup>

Supply voltage ( $V_{IN}$ ) .....	40V
$V_{SW}$ .....	-0.3V (-5V for <10ns) to $V_{IN} + 0.3V$ (43V for <10ns)
$V_{BST}$ .....	$V_{SW} + 5.5V$
$V_{EN}$ .....	-0.3V to +10V <sup>(2)</sup>
$V_{OUT}, V_{USB}$ .....	-0.3V to +6.5V
All other pins .....	-0.3V to +5.5V
Continuous power dissipation ( $T_A = +25^\circ C$ ) <sup>(3)</sup>	
QFN-26 (5mmx5mm) .....	6.25W
Junction temperature .....	150°C
Lead temperature .....	260°C
Storage temperature .....	-65°C to +150°C

**Recommended Operating Conditions** <sup>(4)</sup>

Operation input voltage range .....	6V to 36V
Output current .....	3A (USB1), 3A (USB2)
Operating junction temp. ( $T_J$ ) ...	-40°C to +125°C

<b>Thermal Resistance</b>	$\theta_{JA}$	$\theta_{JC}$
QFN-26 (5mmx5mm)		
JESD51-7 <sup>(5)</sup> .....	44 .....	9 .....
50mmx50mm 4-Layer PCB ...	20 .....	2 .....
		°C/W
		°C/W

**NOTES:**

- 1) Absolute maximum ratings are rated under room temperature unless otherwise noted. Exceeding these ratings may damage the device.
- 2) For details on EN's ABS max rating, please refer to the EN Control section on page 11.
- 3) The maximum allowable power dissipation is a function of the maximum junction temperature  $T_J$  (MAX), the junction-to-ambient thermal resistance  $\theta_{JA}$ , and the ambient temperature  $T_A$ . The maximum allowable continuous power dissipation at any ambient temperature is calculated by  $P_D$  (MAX) =  $(T_J$  (MAX) -  $T_A$ ) /  $\theta_{JA}$ . Exceeding the maximum allowable power dissipation produces an excessive die temperature, causing the regulator to go into thermal shutdown. Internal thermal shutdown circuitry protects the device from permanent damage. Measured on 4 layers PCB (50mmx50mm).
- 4) The device is not guaranteed to function outside of its operating conditions.
- 5) Measured on JESD51-7 and 4-layer PCB.

## ELECTRICAL CHARACTERISTICS

$V_{IN} = 12V$ ,  $V_{EN} = 5V$ ,  $CC1 = CC3 = 5.1k\Omega$ ,  $T_J = -40^\circ C$  to  $+125^\circ C$  <sup>(6)</sup>, typical value is tested at  $T_J = +25^\circ C$ , unless otherwise noted.

Parameter	Symbol	Condition	Min	Typ	Max	Units
Supply current (shutdown)	$I_{IN}$	$V_{EN} = 0V$		13	18	$\mu A$
Supply current (quiescent)	$I_{Q1}$	No switching		1	2	mA
	$I_{Q2}$	CC floating, $V_{BUS}$ disabled, $T_J = +25^\circ C$		200	300	$\mu A$
EN rising threshold	$V_{EN\_Rising}$		-3%	1.235	+3%	V
EN hysteresis	$V_{EN\_HYS}$			200		mV
EN pull-up current	$I_{EN}$		4	8	12	$\mu A$
Thermal shutdown <sup>(7)</sup>	$T_{TSD}$			165		$^\circ C$
Thermal hysteresis <sup>(7)</sup>	$T_{TSD\_HYS}$			20		$^\circ C$
VCC regulator	$V_{CC}$		4.2	4.5	4.85	V
VCC load regulation	$V_{CC\_LOG}$	$I_{CC} = 50mA$		1	3	%
<b>Step-Down Converter</b>						
$V_{IN}$ under-voltage lockout threshold rising	$V_{IN\_UVLO}$		4.6	5	5.4	V
$V_{IN}$ under-voltage lockout threshold hysteresis	$V_{UVLO\_HYS}$			700		mV
HS switch on resistance	$R_{DSON\_HS}$			18		m $\Omega$
LS switch on resistance	$R_{DSON\_LS}$			15		m $\Omega$
Output voltage	$V_{OUT}$	OUT_SEL = low, $T_J = +25^\circ C$	-1.5%	5.1	+1.5%	V
		OUT_SEL = float, $T_J = +25^\circ C$	-1%	5.17	+1%	
		OUT_SEL = float, $T_J = -40^\circ C$ to $+125^\circ C$	-2%	5.17	+2%	
		OUT_SEL = high, $T_J = +25^\circ C$	-1.5%	5.3	+1.5%	
Output over-voltage protection	$V_{OVP\_R}$		5.45	5.85	6.25	V
Output OVP recovery	$V_{OVP\_F}$		5.3	5.7	6.1	V
Output to ground resistance	$R_{Discharge}$			175		k $\Omega$
Low-side current limit	$I_{LS\_LIMIT}$			-2		A
Switch leakage	$SW_{LKG}$	$V_{EN} = 0V$ , $V_{SW} = 36V$ or $0V$ , $T_J = +25^\circ C$			1	$\mu A$
		$V_{EN} = 0V$ , $V_{SW} = 36V$ or $0V$ , $T_J = -40^\circ C$ to $+125^\circ C$			5	
High-side current limit	$I_{LIMIT}$	40% duty cycle	9	13		A
Oscillator frequency	$F_{SW1}$	Pull $R_{FREQ}$ to GND		235		kHz
	$F_{SW2}$	$R_{FREQ} = 66.5k\Omega$		350		
	$F_{SW3}$	$R_{FREQ} = 9.53k\Omega$		2200		
	$F_{SW4}$	$R_{FREQ} = float$	350	450	530	
Maximum duty cycle	$D_{MAX}$	FREQ = 450kHz		95		%

**ELECTRICAL CHARACTERISTICS** (continued)

 $V_{IN} = 12V$ ,  $V_{EN} = 5V$ ,  $CC1 = CC3 = 5.1k\Omega$ ,  $T_J = -40^{\circ}C$  to  $+125^{\circ}C$  <sup>(6)</sup>, typical value is tested at  $T_J = +25^{\circ}C$ , unless otherwise noted.

Parameter	Symbol	Condition	Min	Typ	Max	Units
Minimum off time	$T_{OFF\_MIN}$			110		ns
Minimum on time <sup>(7)</sup>	$T_{ON\_MIN}$			130		ns
Soft-start time	$T_{SS}$	Output from 10% to 90%, $T_J = +25^{\circ}C$		2		ms
<b>USB Switch (USB1 and USB2)</b>						
Under-voltage lockout threshold rising	$V_{USB\_UVR}$		3.7	4	4.3	V
Under-voltage lockout threshold hysteresis	$V_{USB\_UVHYS}$			200		mV
Switch on resistance	$R_{DSON\_SW}$			13		m $\Omega$
Output discharge resistance	$R_{DIS\_USB}$	Apply 5V voltage on USB output, CC pin float		500		k $\Omega$
USB OVP clamp	$V_{USB\_OV}$		5.3	5.6	5.9	V
Current limit	$I_{Limit1}$	$V_{OUT}$ drops 10%, Type-C mode	3.1	3.45	3.8	A
	$I_{Limit2}$	$T_J = +25^{\circ}C$ , $V_{OUT}$ drops 10%, Type-A mode	2.6	2.75	2.9	
Line drop compensation	$V_{DROP\_COM}$	$I_{out}=2.4A$ , $V_{OUT} = 5V$ , $T_J = +25^{\circ}C$		90		mV
$V_{BUS}$ soft-start time	$T_{SS}$	Output from 10% to 90%	1	2	3	ms
Hiccup mode on time	$T_{HICP\_ON2}$	OC, $V_{OUT}$ drops 10%, $T_J = +25^{\circ}C$	3.5	5	6.5	ms
		OC, $V_{OUT}$ drops 10%, $T_J = -40^{\circ}C$ to $+125^{\circ}C$	3	5	7	
Hiccup mode off time	$T_{HICP\_OFF}$	$V_{OUT}$ connected to GND		2		s
<b>BC1.2 DCP Mode</b>						
DP and DM short resistance	$R_{DP/DM\_Short}$	$V_{DP} = 0.8V$ , $I_{DM} = 1mA$ , $T_J = +25^{\circ}C$		85	155	$\Omega$
		$V_{DP} = 0.8V$ , $I_{DM} = 1mA$ , $T_J = -40^{\circ}C$ to $+125^{\circ}C$		85	160	
<b>Divider Mode</b>						
DP/DM output voltage	$V_{DP/DM\_Divider}$		2.55	2.7	2.85	V
DP/DM output impedance	$R_{DP/DM\_Divider}$	$T_J = +25^{\circ}C$	14	22	30	k $\Omega$
		$T_J = -40^{\circ}C$ to $+125^{\circ}C$	12	22	34	
<b>1.2V/1.2V Mode</b>						
DP/DM output voltage	$V_{DP/DM\_1.2V}$	$V_{OUT} = 5V$ , $T_J = +25^{\circ}C$	1.12	1.2	1.28	V
		$V_{OUT} = 5V$ , $T_J = -40^{\circ}C$ to $+125^{\circ}C$	1.1	1.2	1.3	
DP/DM output impedance	$R_{DP/DM\_1.2V}$	$T_J = +25^{\circ}C$	70	105	140	k $\Omega$
		$T_J = -40^{\circ}C$ to $+125^{\circ}C$	60	105	150	

**ELECTRICAL CHARACTERISTICS** (continued)

$V_{IN} = 12V$ ,  $V_{EN} = 5V$ ,  $CC1 = CC3 = 5.1k\Omega$ ,  $T_J = -40^{\circ}C$  to  $+125^{\circ}C$  <sup>(6)</sup>, typical value is tested at  $T_J = +25^{\circ}C$ , unless otherwise noted.

Parameter	Symbol	Condition	Min	Typ	Max	Units
<b>USB Type-C 5V @ 3A Mode – CC1, CC2, CC3, and CC4</b>						
CC resistor to disable Type-C mode	$R_A$	CC1 and CC3	70		90	k $\Omega$
CC voltage to enable $V_{CONN}$	$V_{Ra}$				0.75	V
CC voltage to enable $V_{BUS}$	$V_{Rd}$		0.9		2.45	V
CC detach threshold	$V_{Detach}$		2.75			
CC voltage falling debounce timer	$T_{CC\_debounce}$	$V_{BUS}$ enable deglitch	100	144	200	ms
CC voltage rising debounce timer	$T_{PD\_debounce}$	$V_{BUS}$ disable deglitch	10	15	20	ms
$V_{CONN}$ output power	$P_{VCONN}$	$V_{CONN}$ comes from the buck output with some series resistance, $T_J = +25^{\circ}C$	1			W

**NOTES:**

- 6) All min/max parameters are tested at  $T_J = 25^{\circ}C$ . Limits over temperature are guaranteed by design, characterization, and correlation.
- 7) Guaranteed by design and characterization test.

## TYPICAL PERFORMANCE CHARACTERISTICS

$V_{IN} = 12V$ ,  $V_{OUT} = 5.17V$ ,  $L = 8\mu H$ ,  $T_A = 25^\circ C$ , unless otherwise noted.

**Efficiency vs. Load Current**

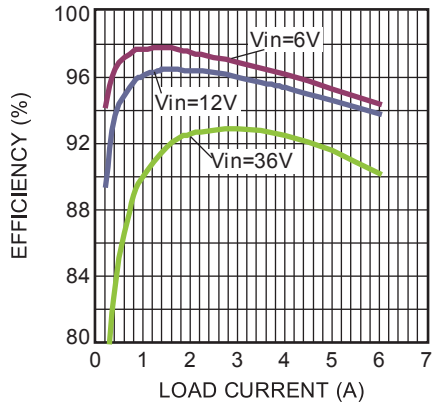

**Line Drop Compensation vs. Load Current**

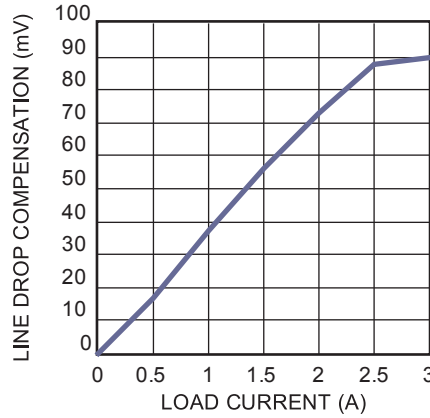

**Radiated EMI**

$V_{IN}=12V, V_{OUT}=5.17V,$   
 $USB1\_I_{OUT}=USB2\_I_{OUT}=3A$

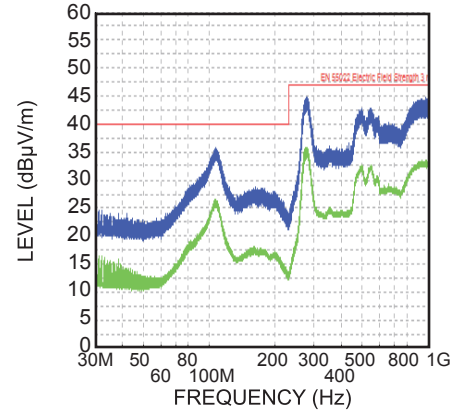

**TYPICAL PERFORMANCE CHARACTERISTICS (continued)**

$V_{IN} = 12V$ ,  $V_{OUT} = 5.17V$ ,  $L = 8\mu H$ ,  $T_A = 25^\circ C$ , unless otherwise noted.

**Output Ripple**

$V_{IN}=12V$ ,  $V_{OUT}=5.17V$ ,  
 $USB1\_I_{OUT}=USB2\_I_{OUT}=0A$

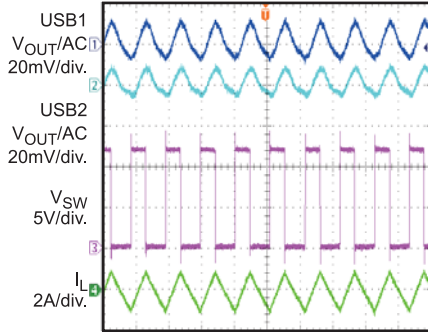

4µs/div.

**Output Ripple**

$V_{IN}=12V$ ,  $V_{OUT}=5.17V$ ,  
 $USB1\_I_{OUT}=USB2\_I_{OUT}=3A$

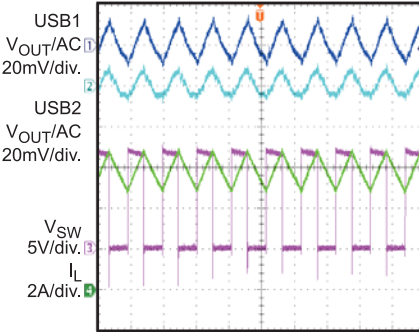

4µs/div.

**Power Start-Up**

$V_{IN}=12V$ ,  $V_{OUT}=5.17V$ ,  
 $USB1\_I_{OUT}=USB2\_I_{OUT}=0A$

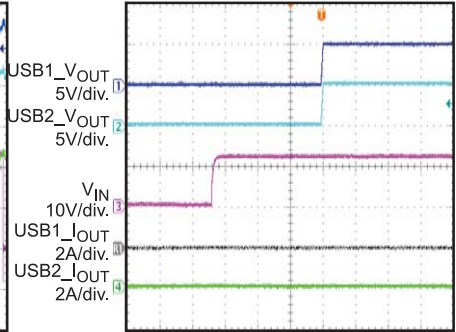

40ms/div.

**Power Start-Up**

$V_{IN}=12V$ ,  $V_{OUT}=5.17V$ ,  
 $USB1\_I_{OUT}=USB2\_I_{OUT}=3A$

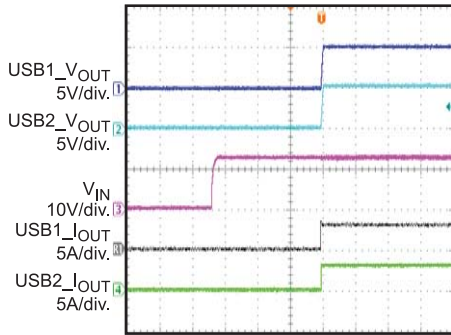

40ms/div

**Power Shutdown**

$V_{IN}=12V$ ,  $V_{OUT}=5.17V$ ,  
 $USB1\_I_{OUT}=USB2\_I_{OUT}=0A$

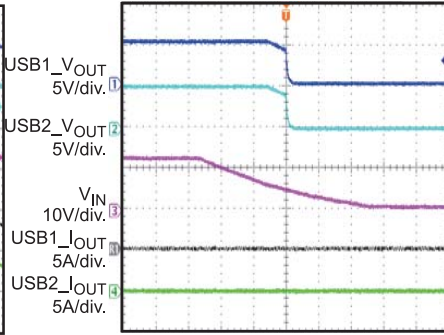

20ms/div

**Power Shutdown**

$V_{IN}=12V$ ,  $V_{OUT}=5.17V$ ,  
 $USB1\_I_{OUT}=USB2\_I_{OUT}=3A$

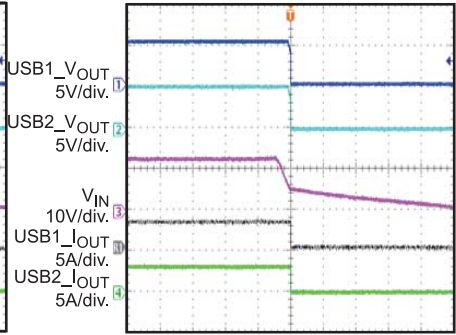

10ms/div

**USB Over-Current Protection**

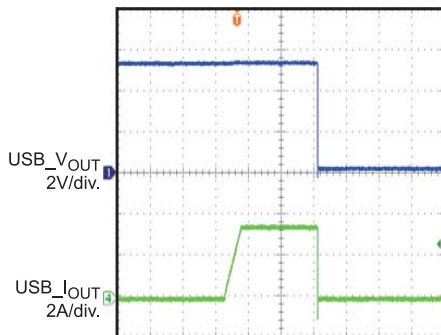

2ms/div



## PIN FUNCTIONS

QFN 5x5 Pin #	Name	Description
1	CC1	<b>Configuration channel.</b> CC1 is used to detect connections and configure the interface across the USB1 Type-C cables and connectors. Once a connection is established, CC1 or CC2 is reassigned to provide power over the V <sub>CONN</sub> pin of the plug.
2	USB1	<b>USB1 output.</b>
3, 15, 25	OUT	<b>Buck output.</b> OUT is the power input for USB1 and USB2.
4, 14	IN	<b>Supply voltage.</b> IN is the drain of the internal power device and provides power to the entire chip. The MP5408M operates from a 6V to 36V input voltage. The input capacitor (C <sub>IN</sub> ) prevents large voltage spikes at the input. Place C <sub>IN</sub> as close to the IC as possible.
5, 13	PGND	<b>Power ground.</b> PGND is the reference ground of the regulated output voltage. PGND requires extra care during the PCB layout. Connect PGND with copper traces and vias.
6	AGND	<b>Analog ground.</b> Connect AGND to PGND.
7	VCC	<b>Internal 4.5V LDO regulator output.</b> Decouple VCC with a 1μF capacitor.
8, 9, 26	SW	<b>Switch output.</b> Use a wide PCB trace to make the connection.
10	BST	<b>Bootstrap.</b> A 0.22μF capacitor is connected between SW and BST to form a floating supply across the high-side switch driver.
11	OUT_SEL	<b>Buck output voltage set.</b> By setting OUT_SEL to low, float, or high, three different output voltages can be achieved: 5.1V, 5.17V, or 5.3V.
12	FREQ	<b>Switching frequency program input.</b> Connect a resistor from FREQ to GND to set the switching frequency. Float FREQ or connect FREQ to VCC for the default 450kHz frequency. Connect FREQ to ground for a 235kHz internal frequency.
16	USB2	<b>USB2 output.</b>
17	CC4	<b>Configuration channel.</b> CC4 is used to detect connections and configure the interface across the USB2 Type-C cables and connectors. Once a connection is established, CC3 or CC4 is reassigned to provide power over the V <sub>CONN</sub> pin of the plug.
18	CC3	<b>Configuration channel.</b> CC3 is used to detect connections and configure the interface across the USB2 Type-C cables and connectors. Once a connection is established, CC3 or CC4 is reassigned to provide power over the V <sub>CONN</sub> pin of the plug.
19	DM2	<b>D- data line to USB2 connector.</b> DM2 is the input/output used for handshaking with portable devices.
20	DP2	<b>D+ data line to USB2 connector.</b> DP2 is the input/output used for handshaking with portable devices.
21	EN	<b>On/off control input.</b> EN has an internal auto pull-up with a 8μA current source.
22	DP1	<b>D+ data line to USB1 connector.</b> DP1 is the input/output used for handshaking with portable devices.
23	DM1	<b>D- data line to USB1 connector.</b> DM1 is the input/output used for handshaking with portable devices.
24	CC2	<b>Configuration channel.</b> CC2 is used to detect connections and configure the interface across the USB1 Type-C cables and connectors. Once a connection is established, CC1 or CC2 is reassigned to provide power over the V <sub>CONN</sub> pin of the plug.

## BLOCK DIAGRAM

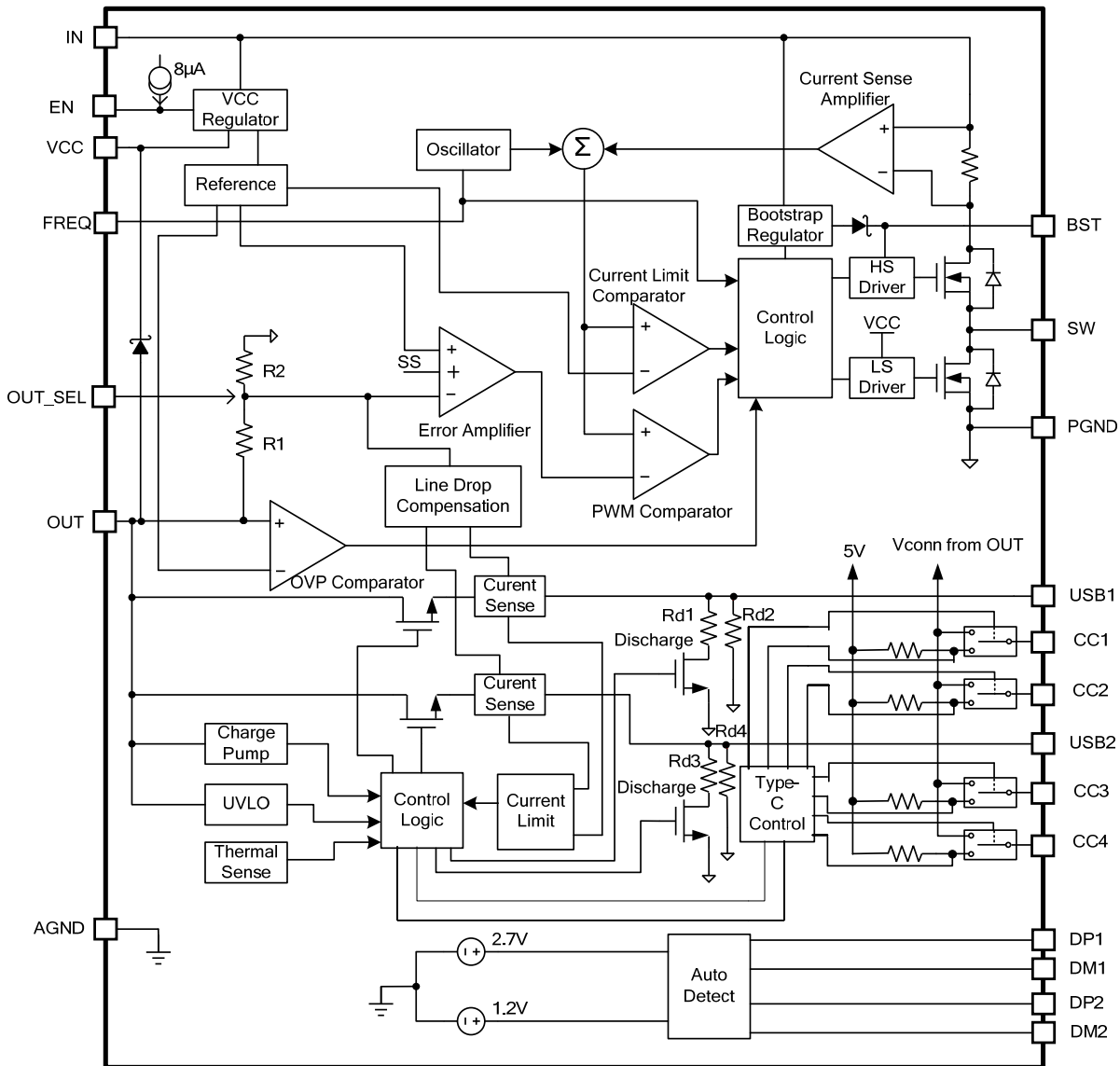

Figure 1: Functional Block Diagram

## OPERATION

### BUCK CONVERTER SECTION

The MP5408M integrates a monolithic, synchronous, rectified, step-down, switch-mode converter with internal power MOSFETs and two USB current-limit switches with charging-port auto-detection. The MP5408M offers a compact solution that achieves 6A of continuous output current with excellent load and line regulation over a wide input supply range.

The MP5408M operates in a fixed-frequency, peak-current-mode control to regulate the output voltage. The internal clock initiates the pulse-width modulation (PWM) cycle, which turns on the integrated high-side power MOSFET (HS-FET). The HS-FET remains on until its current reaches the value set by the COMP voltage ( $V_{COMP}$ ). When the power switch is off, it remains off until the next clock cycle begins. If the duty cycle reaches 95% (450kHz switching frequency) in one PWM period, the current in the power MOSFET does not reach the COMP-set current value, and the power MOSFET turns off.

### Error Amplifier (EA)

The error amplifier (EA) compares the internal feedback voltage against the internal reference (REF) and outputs  $V_{COMP}$ .  $V_{COMP}$  controls the power MOSFET current. The optimized, internal compensation network minimizes the external component count and simplifies the control loop design.

### Internal VCC Regulator

The 4.5V internal regulator powers most of the internal circuitries. This regulator takes  $V_{IN}$  and operates in the full  $V_{IN}$  range. When  $V_{IN}$  exceeds 4.5V, the output of the regulator is in full regulation. If  $V_{IN}$  is less than 4.5V, the output decreases with  $V_{IN}$ . VCC requires an external 1 $\mu$ F ceramic decoupling capacitor.

After the buck output starts up, the internal VCC LDO output is biased by the buck output through a Schottky diode.

### Enable (EN) Control

The MP5408M has an enable (EN) control pin. An internal 8 $\mu$ A pull-up current allows EN to be floated for automatic start-up. Pull EN high or float EN to enable the IC. Pull EN low to disable the IC.

EN is clamped internally using a 7.6V series Zener diode and a 10V break-down voltage of the ESD cell (see Figure 2).

Connect EN through a pull-up resistor to  $V_{IN}$  to enhance the EN pull-up current ability. This requires limiting the EN voltage below 10V or limiting EN input current below 500 $\mu$ A if the EN pull-up voltage is larger than 10V.

For example, if connecting EN to  $V_{IN} = 36V$ , then  $R_{PULLUP} \geq (36V - 10V) / 500\mu A = 52k\Omega$ .

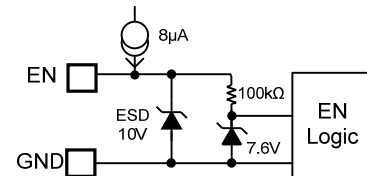

**Figure 2: Zener Diode between EN and GND**

### Setting the Switching Frequency

Connect a resistor from FREQ to ground to set the switching frequency (see Table 1). The value of the frequency can be calculated approximately with Equation (1):

$$FREQ(kHz) = \frac{1000000}{42.5 \times R_{FREQ}(K\Omega) + 53.7} \quad (1)$$

The frequency vs.  $R_{FREQ}$  is shown in Figure 3.

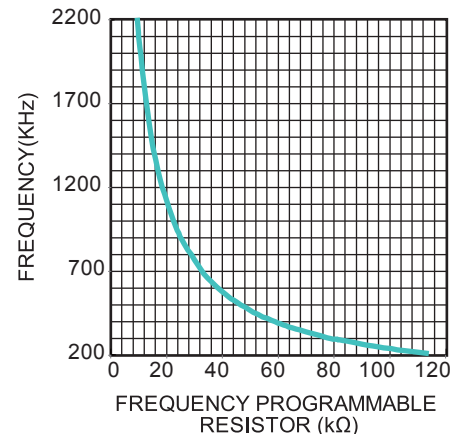
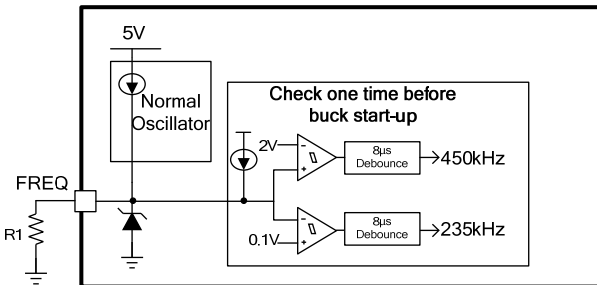

**Figure 3: Switching Frequency vs.  $R_{FREQ}$**

**Table 1: Recommended Resistor Values for Typical Switching Frequency**

R <sub>FREQ</sub> (kΩ)	F <sub>s</sub> (kHz)
0	235
66.5	350
NS	450
45.8	500
22.3	1000
14.6	1500
9.53	2200

Two internal comparators monitor FREQ's logic voltage to enable FREQ to float or short to GND. During power-up, there is another internal source current on FREQ. The frequency is locked at 450kHz when a voltage greater than 2V and a current greater than 8μs is sensed on FREQ. The frequency is locked at 235kHz when a voltage less than 0.1V and a current greater than 8μs is sensed on FREQ. Leave FREQ floating or connect FREQ to VCC to achieve the 450kHz default switching frequency. Short FREQ to ground to achieve a 235kHz frequency (see Figure 4).

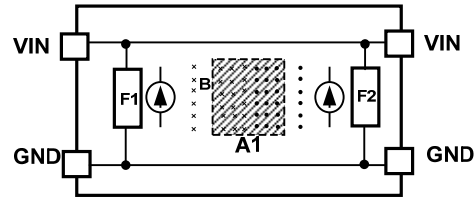

**Figure 4: Switching Frequency Functional Block**

**Electromagnetic Interference (EMI)**

Based on MPS's flip-chip package technology, the MP5408M integrates two sets of EMI filters to reduce the input path's parasitic inductance dramatically. Simultaneously, the input pin and GND pin are assigned on two sides symmetrically, partially cancelling the magnetic field inside those two filters (see Figure 5). The magnetic field in the overlap area (A1) is partially cancelled.

Using the above technique, the radiated emission performance is improved greatly.



**Figure 5: EMI Reduction**

**Under-Voltage Lockout (UVLO)**

Under-voltage lockout (UVLO) protects the chip from operating at an insufficient supply voltage. The UVLO comparator monitors the input voltage. The UVLO rising threshold is 5V, and its falling threshold is 4.3V.

**Internal Soft Start (SS)**

Soft start (SS) prevents the converter output voltage from overshooting during start-up. When the chip starts up, the internal circuitry generates a SS voltage that ramps up from 0V to 5V. When SS is lower than REF, the error amplifier uses SS as the reference. When SS is higher than REF, the error amplifier uses REF as the reference. The SS time is set to 2ms internally. If the output of the MP5408M is pre-biased to a certain voltage during start-up, the IC disables the switching of both the high-side and low-side switches until the voltage on the internal SS capacitor exceeds the internal feedback voltage.

**Forced CCM Operation**

The MP5408M works in forced continuous conduction mode (CCM) continuously. The MP5408M operates in a fixed switching frequency regardless of whether it is operating in light load or full load. The advantage of CCM is the controllable frequency, smaller output ripple, and sufficient bootstrap charge time, but it also has low efficiency at light-load condition. A proper inductance should be selected to avoid triggering the low-side switch's negative current limit (typically 2A, from SW to GND). If the negative current limit is triggered, the low-side switch turns off, and the high-side switch turns on when the internal clock comes around.

**Buck Over-Current Protection (OCP)**

The MP5408M has a cycle-by-cycle over-current limit when the inductor peak current exceeds the current-limit threshold, and the FB voltage drops below the under-voltage (UV)

threshold (typically 50% below the reference). Once UV is triggered, the MP5408M enters hiccup mode to restart the part periodically. This protection mode is especially useful when the output is dead-shortened to ground. This reduces the average short-circuit current greatly, alleviates thermal issues, and protects the regulator. The MP5408M exits hiccup mode once the over-current condition is removed.

**Buck Output Over-Voltage Protection (OVP)**

The MP5408M has output over-voltage protection (OVP). If the output is higher than 5.85V, the high-side switch stops turning on. The low-side switch turns on to discharge the output voltage until the output decreases to 5.7V, and then the chip resumes normal operation.

**Floating Driver and Bootstrap Charging**

An external bootstrap capacitor powers the floating power MOSFET driver. This floating driver has its own UVLO protection. The UVLO’s rising threshold is 2.2V with a hysteresis of 150mV. The bootstrap capacitor voltage is regulated internally by VIN and VCC through D1, D2, M1, C4, L1 and C2 (see Figure 5). BST capacitor C4 voltage will be charged up quickly by VCC through M1. The 2.5µA input to BST current source also can charge the BST capacitor when low-side switch doesn’t turn-on.

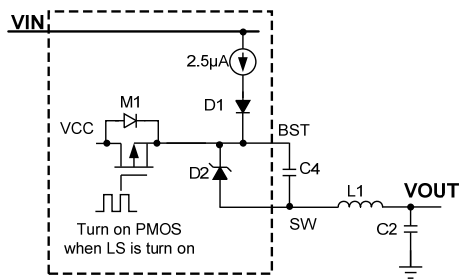

**Figure 6: Internal Bootstrap Charging Circuit**

**Start-Up and Shutdown**

If both IN and EN exceed their respective thresholds, the chip is enabled. The reference block starts first, generating a stable reference voltage and current, and then the internal regulator is enabled. The regulator provides a stable supply for the remaining circuitries.

Three events can shut down the chip: EN low, IN low, and thermal shutdown. In shutdown, the signaling path is blocked to avoid any fault

triggering. Then  $V_{COMP}$  and the internal supply rail are pulled down. The floating driver is not subject to this shutdown command.

**Buck Output Impedance**

The Buck doesn't involve output discharge function during EN shutdown. After EN shutdown, there is only two feedback resistor connected to the OUT pin, which has a typical resistance of 175kΩ in total. Refer to the block diagram.

**USB CURRENT-LIMIT SWITCH SECTION**

**Over-Current Protection (OCP) and Hiccup**

The MP5408M integrates two USB current-limit switches. The MP5408M provides built-in soft-start circuitry which controls the rising slew rate of the output voltage to limit inrush current and voltage surges.

When the load current reaches the current-limit threshold the USB power MOSFET works in constant current-limit mode (see Figure 7). If the over-current limit condition lasts more than 5ms ( $V_{OUT}$  does not drop too low), the corresponding USB channel enters hiccup mode with 5ms of on-time and 2s of off-time. Another USB channel works normally.

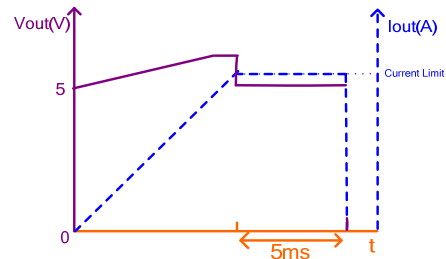

**Figure 7: Over-Current Limit**

After the soft start finishes, if the USB output voltage is lower than 3.5V and lasts longer than 50µs, the MP5408M enters hiccup without having to wait 5ms (see Figure 8). This can prevent abnormal thermal rise during the constant resistor (CR) load over-current case.

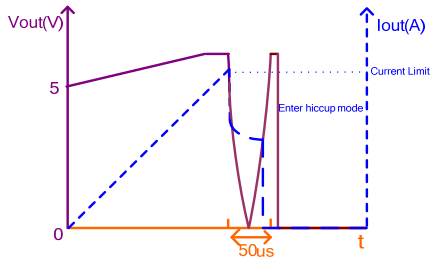

**Figure 8: Over-Current Limit for CR Load**

**Fast Response for Short-Circuit Protection (SCP)**

If the load current increases rapidly due to a short-circuit event, the current may exceed the current limit threshold before the control loop is able to respond. If the current reaches the 7A secondary current limit level, a fast turn-off circuit activates to turn off the power MOSFET. This can help limit the peak current through the switch, keeping the buck output voltage from dropping too much and affecting another USB channel. The total short-circuit response time is less than 1µs.

When the fast turn-off function is triggered, the MOSFET turns off for 100µs and restarts with a soft start. During the restart process, if the short still remains, the MP5408M regulates the gate voltage to hold the current at a normal current limit level.

**Output Line Drop Compensation**

The MP5408M can compensate for an output voltage drop, such as high impedance caused by a long trace, to maintain a fairly constant output voltage at the load-side voltage.

The internal comparator compares the current-sense output voltage of the two current-limit switches and uses the larger current-sense output voltage to compensate for the line drop voltage.

The line drop compensation amplitude increases linearly as the load current increases. It also has an upper limitation. The line drop compensation at a 3A output current is 90mV.

**USB Output Over-Voltage Clamp**

To protect the device at the cable terminal, the USB switch output has a fixed over-voltage protection (OVP) threshold. When the input voltage is higher than the OVP threshold, the output voltage is clamped at 5.6V.

**USB Output Discharge and Impedance**

Each USB switch involves a fast discharge path that can quickly discharge the external output capacitor's energy during power shutdown. This function will be active when the CC pins are released or the part is disabled (input voltage is under UVLO or enable off). The discharge path is turned off when USB output voltage is discharged lower than 50mV. After turn-off the fast discharge path, there is only a high impedance resistor (typical 500kΩ) from USB1 or USB2 to ground.

**Auto-Detection**

The MP5408M integrates a USB dedicated charging port auto-detect function. This function recognizes most mainstream portable devices and supports the following charging schemes:

USB battery charging specification BC1.2/ Chinese Telecommunications Industry standard YD/T 1591-2009

- Apple divider mode
- 1.2V/1.2V mode
- USB Type-C 5V @ 3A DFP mode

The auto-detect function is a state machine that supports all of the DCP charging schemes above. Connect DP and DM with 150Ω resistor for DCP mode.

**USB Type-C Mode and V<sub>CONN</sub>**

For USB Type-C solutions, two pins (CC1 and CC2) on the connector are used to establish and manage the source-to-sink connection. The general concept for setting up a valid connection between a source and a sink is based on being able to detect terminations residing in the product being attached. To aid in defining the functional behavior of CC, a pull-up (Rp) and pull-down (Rd 5.1kΩ) termination model is used based on a pull-up resistor and pull-down resistor (see Figure 9).

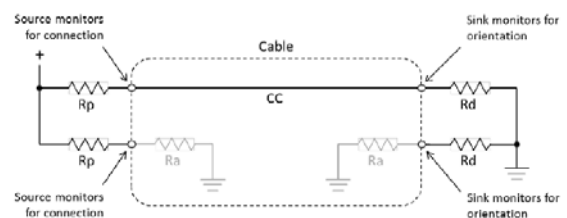
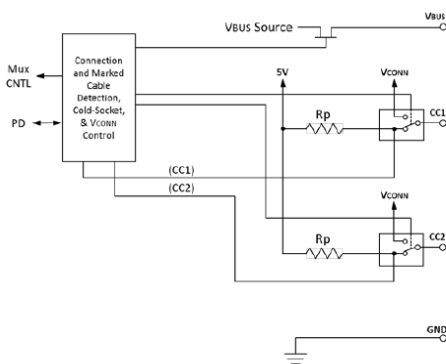

**Figure 9: Current Source/Pull-Down CC Model**

Initially, a source exposes independent  $R_p$  terminations on its CC1 and CC2 pins, and a sink exposes independent  $R_d$  terminations on its CC1 and CC2 pins. The source-to-sink combination of this circuit configuration represents a valid connection. To detect this, the source monitors CC1 and CC2 for a voltage lower than its unterminated voltage. The choice of  $R_p$  is a function of the pull-up termination voltage and the source's detection circuit. This indicates that either a sink, a powered cable, or a sink connected via a powered cable has been attached. Prior to the application of  $V_{CONN}$ , a powered cable exposes  $R_a$  (typically  $1k\Omega$ ) on its  $V_{CONN}$  pin.  $R_a$  represents the load on  $V_{CONN}$  plus any resistive elements to ground. In some cable plugs, this might be a pure resistance, and in others, it may simply be the load.

The source must be able to differentiate between the presence of  $R_d$  and  $R_a$  to know whether there is a sink attached and where to apply  $V_{CONN}$ . The source is not required to source  $V_{CONN}$  unless  $R_a$  is detected.

Two special termination combinations on the CC pins as seen by a source are defined for directly attached accessory modes:  $R_a/R_a$  for audio adapter accessory mode, and  $R_d/R_d$  for debug accessory mode (see Figure 10 and Table 2).



**Figure 10: CC Functional Block**

A port that behaves as a source has the following functional characteristics.

1. The source uses a MOSFET to enable or disable the power delivery across  $V_{BUS}$ . Initially, the source is disabled.
2. The source supplies pull-up resistors ( $R_p$ ) on CC1 and CC2 and monitors both to

detect a sink. The presence of an  $R_d$  pull-down resistor on CC1 or CC2 indicates that a sink is being attached. The value of  $R_p$  indicates the initial USB Type-C current level supported by the host. The MP5408M's  $R_p$  is  $10k\Omega$ , which represents a 3A current level.

3. The source uses the CC pull-down characteristic to detect and determine which CC pin is intended to supply  $V_{CONN}$  (when  $R_a$  is discovered).
4. Once a sink is detected, the source enables  $V_{BUS}$  and  $V_{CONN}$ .
5. The source monitors the continued presence of  $R_d$  to detect a sink detach. When a detach event is detected, the source is removed, and  $V_{BUS}$  and  $V_{CONN}$  return to step 2.

**Disable Type-C Mode (Type-A Mode)**

During the MP5408M initial start-up, the IC sources  $10\mu A$  for  $20\mu s$  on CC1. If the CC1 voltage falls into a  $400mV$  to  $1.2V$  voltage range, USB1 latches in Type-A mode unless the part is re-enabled. Type-C mode is disabled, so CC is attached, the detach logic is disabled and  $V_{BUS}$  is always enabled. The current limit changes to a Type-A spec. The same logic is implemented on CC3 for USB2.

To trigger Type-A mode, the external pull-down resistor should be  $70 - 90k\Omega$ . Do not connect extra capacitors on CC1 and CC3.

In normal Type-C mode application, a  $1nF$  capacitor should be added on CC1 and CC3 respectively to avoid falsely trigger Type-A mode. Refer to the typical schematic for detail.

The MP5408M also supports debug mode and audio adapter accessory mode in Type-C applications. If two  $R_a$  resistors pull down CC1 and CC2, or two  $R_d$  resistors pull down CC1 and CC2, there is no action inside the IC ( $V_{BUS}$  is not enabled).

**Thermal Shutdown**

Thermal shutdown prevents the chip from operating at exceedingly high temperatures. When the silicon die temperature exceeds  $165^\circ C$ , the entire chip shuts down. When the temperature falls below its lower threshold (typically  $145^\circ C$ ), the chip is enabled.

**Table 2: CC Logic Truth Table**

EN	CC of USB1 <sup>(8)</sup>	CC of USB2 <sup>(8)</sup>	Buck	V <sub>CONN</sub> (USB1)	USB1	VCONN (USB2)	USB2
0	X	X	Disabled	Disabled	Disabled	Disabled	Disabled
1	AUDIO	Open or AUDIO or DEBUG	Disabled	Disabled	Disabled	Disabled	Disabled
	DEBUG		Disabled	Disabled	Disabled	Disabled	Disabled
	"A" <sup>(9)</sup>		Enabled	Disabled	Enabled	Disabled	Disabled
	Rd, Ra		Enabled	Enabled	Enabled	Disabled	Disabled
	Open		Disabled	Disabled	Disabled	Disabled	Disabled
1	AUDIO	Rd, Ra	Enabled	Disabled	Disabled	Enabled	Enabled
	DEBUG		Enabled	Disabled	Disabled	Enabled	Enabled
	"A"		Enabled	Disabled	Enabled	Enabled	Enabled
	Rd, Ra		Enabled	Enabled	Enabled	Enabled	Enabled
	Open		Enabled	Disabled	Disabled	Enabled	Enabled
1	AUDIO	"A"	Enabled	Disabled	Disabled	Disabled	Enabled
	DEBUG		Enabled	Disabled	Disabled	Disabled	Enabled
	"A"		Enabled	Disabled	Enabled	Disabled	Enabled
	Rd, Ra		Enabled	Enabled	Enabled	Disabled	Enabled
	Open		Enabled	Disabled	Disabled	Disabled	Enabled

**NOTES:**

8) USB1 and USB2 are symmetric to each other.

9) "A" means Type-A mode. CC1 (CC3 for USB2) is requested to be pulled down by a 80.6kΩ resistor to enter this mode.



## APPLICATION INFORMATION

### Selecting the Inductor

For most applications, use an inductor with a DC current rating at least 25% higher than the maximum load current. Select an inductor with a small DC resistance for optimum efficiency. For most designs, the inductor value can be derived with Equation (2):

$$L_1 = \frac{V_{OUT} \times (V_{IN} - V_{OUT})}{V_{IN} \times \Delta I_L \times f_{OSC}} \quad (2)$$

Where  $\Delta I_L$  is the inductor ripple current.

Choose the inductor ripple current to be approximately 30% of the maximum load current. The maximum inductor peak current can be calculated with Equation (3):

$$I_{L(MAX)} = I_{LOAD} + \frac{\Delta I_L}{2} \quad (3)$$

### Selecting the Buck Input Capacitor

The input current to the step-down converter is discontinuous and therefore requires a capacitor to supply AC current while maintaining the DC input voltage. Use low ESR capacitors for optimum performance. Ceramic capacitors with X5R or X7R dielectrics are highly recommended because of their low ESR and small temperature coefficients. 100 $\mu$ F electrolytic and 50 $\mu$ F ceramic capacitors are recommended in applications with a 235kHz switching frequency.

Since the input capacitor (C1) absorbs the input switching current, it requires an adequate ripple current rating. The RMS current in the input capacitor can be estimated with Equation (4):

$$I_{C1} = I_{LOAD} \times \sqrt{\frac{V_{OUT}}{V_{IN}} \times \left(1 - \frac{V_{OUT}}{V_{IN}}\right)} \quad (4)$$

The worst-case condition occurs at  $V_{IN} = 2V_{OUT}$ , shown in Equation (5):

$$I_{C1} = \frac{I_{LOAD}}{2} \quad (5)$$

For simplification, choose an input capacitor with an RMS current rating greater than half of the maximum load current.

The input capacitor can be electrolytic, tantalum, or ceramic. When using an electrolytic capacitor, place two additional high-quality ceramic capacitors as close to IN as possible. Estimate the input voltage ripple caused by the capacitance with Equation (5):

$$\Delta V_{IN} = \frac{I_{LOAD}}{f_s \times C1} \times \frac{V_{OUT}}{V_{IN}} \times \left(1 - \frac{V_{OUT}}{V_{IN}}\right) \quad (5)$$

### Selecting the Buck Output Capacitor

The device requires an output capacitor (C2) to maintain the DC output voltage. Estimate the output voltage ripple with Equation (6):

$$\Delta V_{OUT} = \frac{V_{OUT}}{f_s \times L_1} \times \left(1 - \frac{V_{OUT}}{V_{IN}}\right) \times \left(R_{ESR} + \frac{1}{8 \times f_s \times C2}\right) \quad (6)$$

Where  $L_1$  is the inductor value, and  $R_{ESR}$  is the equivalent series resistance (ESR) value of the output capacitor.

For an electrolytic capacitor, the ESR dominates the impedance at the switching frequency. For simplification, the output ripple can be approximated with Equation (7):

$$\Delta V_{OUT} = \frac{V_{OUT}}{f_s \times L_1} \times \left(1 - \frac{V_{OUT}}{V_{IN}}\right) \times R_{ESR} \quad (7)$$

A 100 - 270 $\mu$ F capacitor with an ESR less than 50m $\Omega$  (e.g.: polymer capacitor or tantalum capacitor) and three 10 $\mu$ F ceramic capacitors are recommended in the application.

For CLA applications, set the switching frequency to be 235kHz for better thermal performance (see Table 3).

**Table 3: Recommended External Components**

Switching Frequency	Inductor	Input Cap	Buck Output Capacitor
235kHz	8 $\mu$ H	50 $\mu$ F ceramic cap + 100 $\mu$ F E-cap	30 $\mu$ F ceramic cap + 270 $\mu$ F Polymer cap
450kHz	4.7 $\mu$ H	50 $\mu$ F ceramic cap + 100 $\mu$ F E-cap	30 $\mu$ F ceramic cap + 270 $\mu$ F Polymer cap

**ESD Protection for I/O Pins**

Higher ESD levels should be considered for all USB I/O pins. The MP5408M features high ESD protection up to ±8kV human body model on DP, DM, USB1, and USB2, and ±5.5kV human body model on CC1 through CC4. The ESD structures can withstand high ESD both in normal operation and when the device is powered off. To further extend DP and DM's ESD level for covering complicated application environments, additional resistors and capacitors can be added (see Figure 11).

Similar R-C networks cannot be added on CC1 or CC2 because the CC line must support 200mA of current and 300kHz of signaling. Additional ESD diodes can be added on the CC pins.

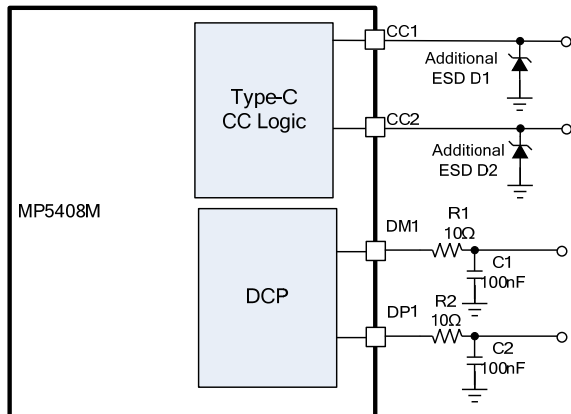

**Figure 11: Recommended I/O Pins ESD Enhancing**

**PC Board Layout <sup>(10)</sup>**

Efficient PCB layout is critical for stable operation and thermal dissipation. For best results, refer to Figure 12 and follow the guidelines below.

1. Use short, direct, and wide traces to connect OUT.
2. Add vias under the IC.
3. Route the OUT trace on both PCB layers.
4. Place the buck output ceramic capacitor C2A and C2B on one side and C2C on the other side.
5. Add a large copper plane for PGND.
6. Add multiple vias to improve thermal dissipation.
7. Connect AGND to PGND.
8. Place a large copper plane for SW, USB, and USB2.
9. Route the USB1 and USB2 traces on both PCB layers.
10. Add multiple vias.
11. Place two ceramic input decoupling capacitors as close to IN and PGND as possible to improve EMI performance.
12. Place the VCC decoupling capacitor as close to VCC as possible.

**NOTE:**

10) The recommended layout is based on the Typical Application Circuits in Figure 13 through Figure 15.

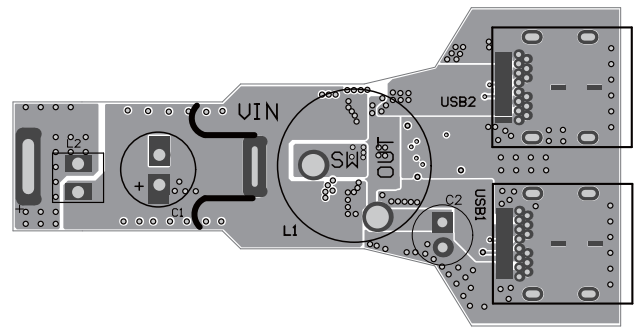

**Top Layer**

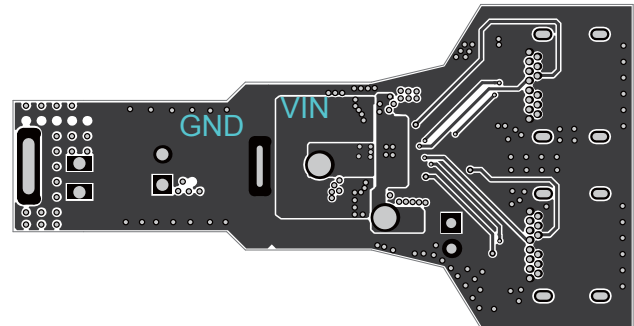

**Middle Layer 1**

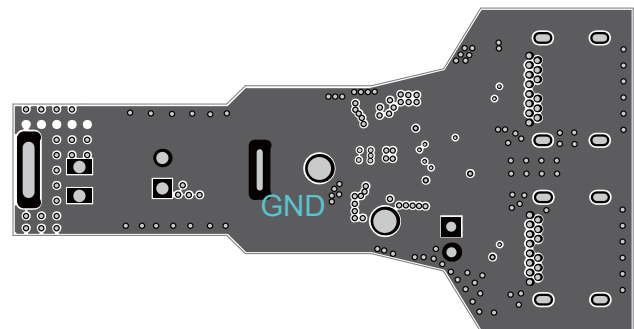

**Middle Layer 2**

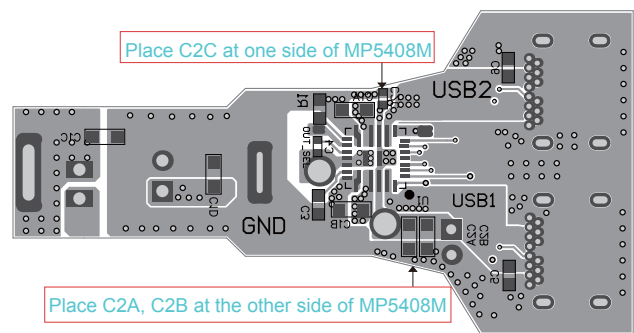

**Bottom Layer**

**Figure 12: Recommended Layout**

**TYPICAL APPLICATION CIRCUITS**

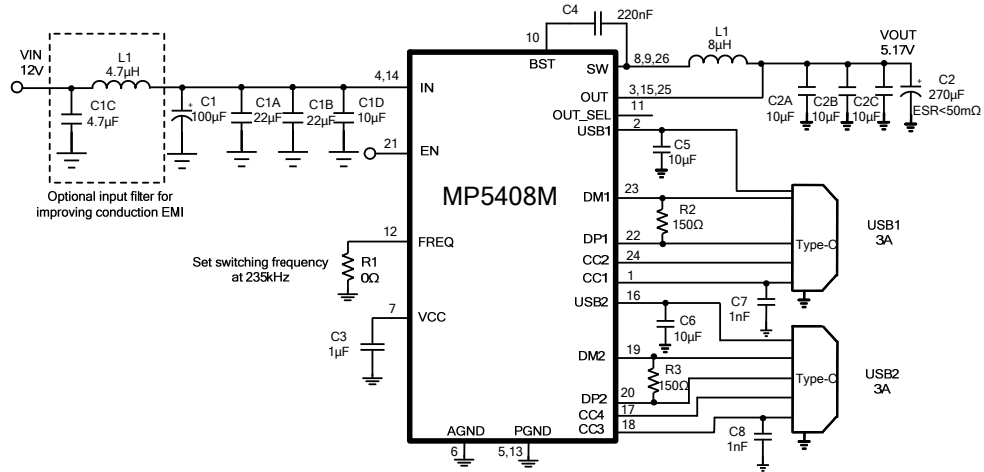

**Figure 13: Dual USB Type-C 5V/3A DFP Ports (11)**

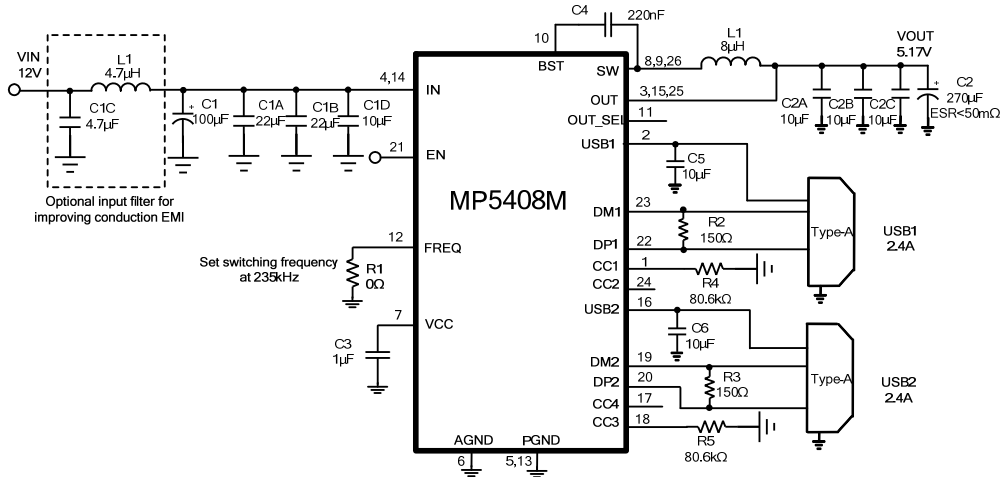

**Figure 14: Dual USB Type-A 5V/2.4A Ports (11)**

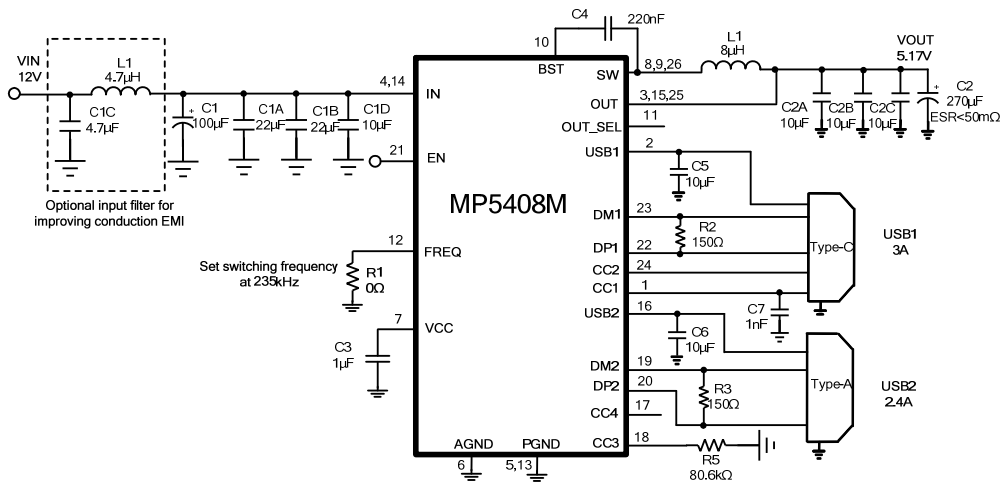

**Figure 15: One Type-C 5V/3A DFP Port, One Type-A 5V/2.4A Port (11)**

**NOTE:**

11) See Figure 11 for I/O pins' ESD protection enhancing details.

**PACKAGE INFORMATION**

**QFN-26 (5mmx5mm)**

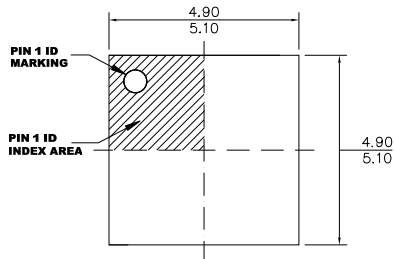

**TOP VIEW**

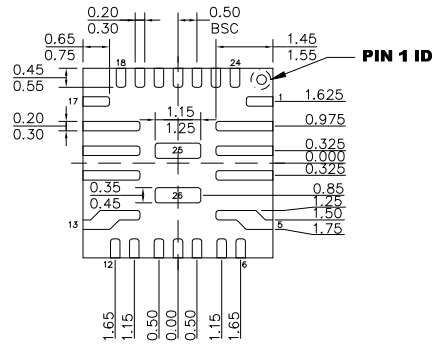

**BOTTOM VIEW**

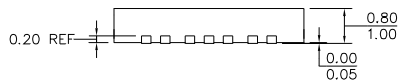

**SIDE VIEW**

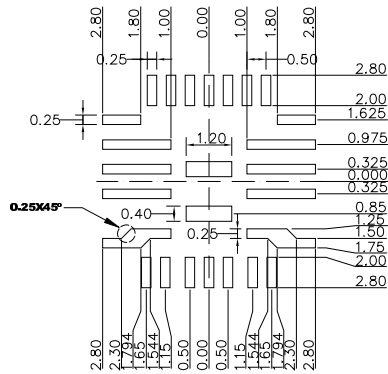

**RECOMMENDED LAND PATTERN**

**NOTE:**

- 1) LAND PATTERNS OF PIN 2-4 AND 14-16 HAVE THE SAME LENGTH AND WIDTH.
- 2) LAND PATTERNS OF PIN 5 AND PIN13 HAVE THE SAME LENGTH AND WIDTH.
- 3) ALL DIMENSIONS ARE IN MILLIMETERS.
- 4) LEAD COPLANARITY SHALL BE 0.10 MILLIMETERS MAX.
- 5) REFERENCE IS MO-220.
- 6) DRAWING IS NOT TO SCALE.

**NOTICE:** The information in this document is subject to change without notice. Users should warrant and guarantee that third party Intellectual Property rights are not infringed upon when integrating MPS products into any application. MPS will not assume any legal responsibility for any said applications.

Компания «Life Electronics» занимается поставками электронных компонентов импортного и отечественного производства от производителей и со складов крупных дистрибьюторов Европы, Америки и Азии.

С конца 2013 года компания активно расширяет линейку поставок компонентов по направлению коаксиальный кабель, кварцевые генераторы и конденсаторы (керамические, пленочные, электролитические), за счёт заключения дистрибьюторских договоров

Мы предлагаем:

- Конкурентоспособные цены и скидки постоянным клиентам.
- Специальные условия для постоянных клиентов.
- Подбор аналогов.
- Поставку компонентов в любых объемах, удовлетворяющих вашим потребностям.
- Приемлемые сроки поставки, возможна ускоренная поставка.
- Доставку товара в любую точку России и стран СНГ.
- Комплексную поставку.
- Работу по проектам и поставку образцов.
- Формирование склада под заказчика.
- Сертификаты соответствия на поставляемую продукцию (по желанию клиента).
- Тестирование поставляемой продукции.
- Поставку компонентов, требующих военную и космическую приемку.
- Входной контроль качества.
- Наличие сертификата ISO.

В составе нашей компании организован Конструкторский отдел, призванный помогать разработчикам, и инженерам.

Конструкторский отдел помогает осуществить:

- Регистрацию проекта у производителя компонентов.
- Техническую поддержку проекта.
- Защиту от снятия компонента с производства.
- Оценку стоимости проекта по компонентам.
- Изготовление тестовой платы монтаж и пусконаладочные работы.



Тел: +7 (812) 336 43 04 (многоканальный)

Email: [org@lifeelectronics.ru](mailto:org@lifeelectronics.ru)