

18 Watt

- Energy Efficiency Level VI
- European CoC Tier 2
- Universal Input
- Output Voltages from 9 V to 24 V
- Class II Construction
- Low Cost



The VET18 series of desk-top power supplies comply with the very latest energy efficiency level VI standards with high active mode efficiency and extremely low no load power consumption. Available with a standard jack plug connector these adaptors suit a wide variety of cost sensitive applications while maintaining industry leading performance.

Dimensions:

VET18:

4.21 x 1.71 x 1.22" (107.0 x 43.5 x 31.0 mm)

Models & Ratings

Output Power	Output Voltage	Output Current	Total Regulation ⁽²⁾	Output Connector	Model Number
18 W	9.0V	2000 mA	5%	5.5 x 2.1 x 12 mm DC Jack	VET18US090C2-JA
	12.0V	1500 mA	5%	5.5 x 2.1 x 12 mm DC Jack	VET18US120C2-JA
	15.0V	1250 mA	5%	5.5 x 2.1 x 12 mm DC Jack	VET18US150C2-JA
	18.0V	1000 mA	5%	5.5 x 2.1 x 12 mm DC Jack	VET18US180C2-JA
	24.0V	750 mA	5%	5.5 x 2.1 x 12 mm DC Jack	VET18US240C2-JA

Notes

1. Other output voltages available, contact sales for details.

2. Total regulation includes initial set accuracy, line and load regulation.

Input

Characteristic	Minimum	Typical	Maximum	Units	Notes & Conditions
Input Voltage	90		264	VAC	
Input Frequency	47		63	Hz	
Input Current			0.6	A	100 VAC
Inrush Current			80	A	240 VAC, cold start at 25 °C
Power Factor					EN61000-3-2, class A
No Load Input Power			75	mW	
Input Protection	Internal T1.0A/250 VAC fuse				

Output

Characteristic	Minimum	Typical	Maximum	Units	Notes & Conditions
Output Voltage	9		24	V	See Models and Ratings table
Minimum Load	0			A	No minimum load required
Start Up Delay			4	s	
Start Up Rise Time		30		ms	
Hold Up Time	8			ms	Full load and 100 VAC
Total Regulation			5	%	See Models and Ratings table
Transient Response			4	% deviation	Recovery within <1% within 500 µs for a 50% step load change at 0.15 A/µs
Ripple & Noise			150	mV pk-pk	Measured with 20 MHz bandwidth and 47 µF electrolytic in parallel with 0.1 µF ceramic capacitor
Short Circuit Protection					Continuous, trip and restart (hiccup mode) with auto recovery
Temperature Coefficient			0.05	%/°C	

General

Characteristic	Minimum	Typical	Maximum	Units	Notes & Conditions
Efficiency		85		%	Typical average of efficiencies measured at 25%, 50%, 75% and 100% load and 115 VAC input
Energy Efficiency					Level VI
Isolation	3000			VAC	Input to Output
Switching Frequency	24		70	kHz	Variable
Mean Time Between Failure	250			kHrs	MIL-HDBK-217F at 25 °C GB
Weight		0.302 (137.0)		lb (g)	

Environmental

Characteristic	Minimum	Typical	Maximum	Units	Notes & Conditions
Operating Temperature	0		+60	°C	Derate from 100% load at 40 °C to 50% load at 60 °C
Storage Temperature	-40		+85	°C	
Operating Humidity	5		95	%	RH, non-condensing
Cooling					Natural convection
Shock					1 m drop onto concrete on each of 6 axes
Vibration	10		300	Hz	2 g 15 mins/sweep, 60 mins for each of 3 axes

EMC: Emissions

Phenomenon	Standard	Test Level	Notes & Conditions
Conducted	EN55032	Level B	
Radiated	EN55032	Level B	
Harmonic Current	EN61000-3-2	Class A	
Voltage Flicker	EN61000-3-3		

EMC: Immunity

Phenomenon	Standard	Test Level	Criteria	Notes & Conditions
ESD Immunity	EN61000-4-2	±4 kV contact, ±8 kV air	A	
Radiated Immunity	EN61000-4-3	3 V/m	A	
EFT/Burst	EN61000-4-4	Level 2	A	
Surge	EN61000-4-5	Level 2	A	
Conducted Immunity	EN61000-4-6	3 V	A	
Magnetic Fields	EN61000-4-8	1 A/m	A	
Dips and Interruptions	EN55024 (115VAC)	100% U _T (0 VAC) for 10 ms	A	
		30% U _T (80.5 VAC) for 500 ms	A	
		100% U _T (0 VAC) for 5000 ms	B	
	EN55024 (230VAC)	100% U _T (0 VAC) for 10 ms	A	
		30% U _T (161 VAC) for 500 ms	A	
		100% U _T (0 VAC) for 5000 ms	B	

Safety Approvals

Phenomenon	Standard
CB Report	IEC60950-1
UL	UL/cUL60950-1, approved as limited power source (LPS)
TUV	EN60950-1
CCC	China Compulsory Certification, GB4943
AU/NZ	AU/NZ 60950.1

Mechanical Details

VET18USXXXC2-JA

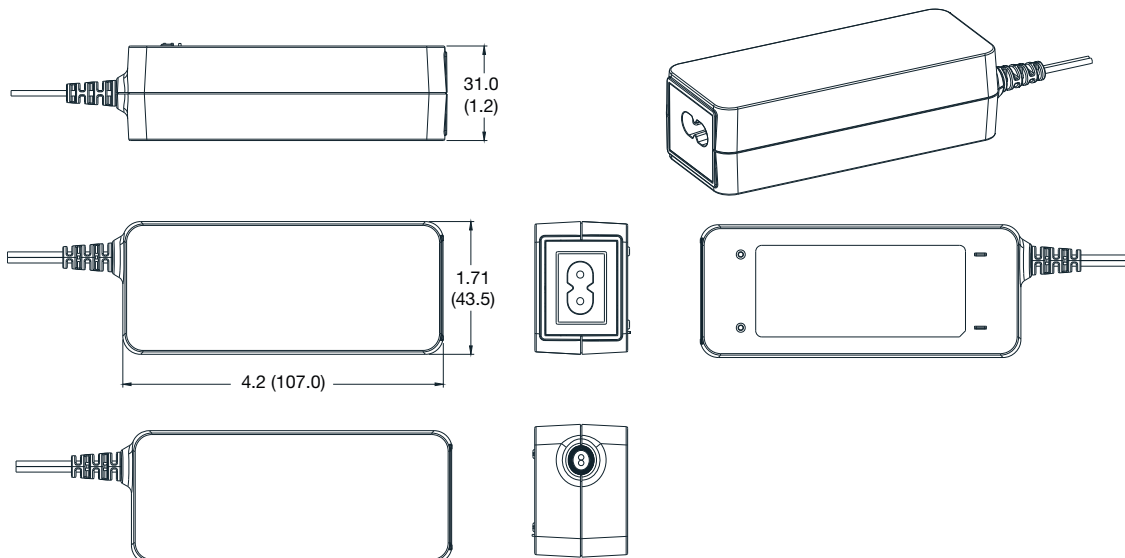

Output Lead and Connection

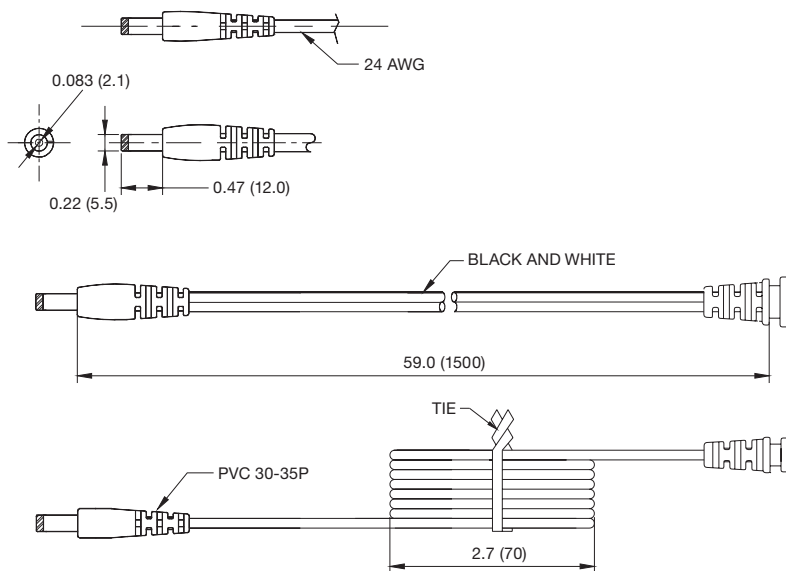

Wire type: VW-1 80°C 300V L=1500 mm 2468, 22 AWG for 12 V output, 24 AWG for other outputs, 2C Black and White. Black - Negative, White - Positive



Компания «Life Electronics» занимается поставками электронных компонентов импортного и отечественного производства от производителей и со складов крупных дистрибьюторов Европы, Америки и Азии.

С конца 2013 года компания активно расширяет линейку поставок компонентов по направлению коаксиальный кабель, кварцевые генераторы и конденсаторы (керамические, пленочные, электролитические), за счёт заключения дистрибьюторских договоров

Мы предлагаем:

- Конкурентоспособные цены и скидки постоянным клиентам.
- Специальные условия для постоянных клиентов.
- Подбор аналогов.
- Поставку компонентов в любых объемах, удовлетворяющих вашим потребностям.
- Приемлемые сроки поставки, возможна ускоренная поставка.
- Доставку товара в любую точку России и стран СНГ.
- Комплексную поставку.
- Работу по проектам и поставку образцов.
- Формирование склада под заказчика.
- Сертификаты соответствия на поставляемую продукцию (по желанию клиента).
- Тестирование поставляемой продукции.
- Поставку компонентов, требующих военную и космическую приемку.
- Входной контроль качества.
- Наличие сертификата ISO.

В составе нашей компании организован Конструкторский отдел, призванный помогать разработчикам, и инженерам.

Конструкторский отдел помогает осуществить:

- Регистрацию проекта у производителя компонентов.
- Техническую поддержку проекта.
- Защиту от снятия компонента с производства.
- Оценку стоимости проекта по компонентам.
- Изготовление тестовой платы монтаж и пусконаладочные работы.



Тел: +7 (812) 336 43 04 (многоканальный)

Email: org@lifeelectronics.ru