



LOW-VOLTAGE OCTAL BUS SWITCH

IDT74CBTLV3245

FEATURES:

- Pin-out compatible with standard '245 Logic products
- 5Ω A/B bi-directional switch
- Isolation under power-off conditions
- Over-voltage tolerant
- Latch-up performance exceeds 100mA
- $V_{CC} = 2.3V - 3.6V$, Normal Range
- ESD > 2000V per MIL-STD-883, Method 3015;
> 200V using machine model (C = 200pF, R = 0)
- Available in QSOP and TSSOP packages

APPLICATIONS:

- 3.3V High Speed Bus Switching and Bus Isolation

DESCRIPTION:

The octal bus switch has standard 245 pinouts. The CBTLV3245 is designed for asynchronous communication between data buses. When Output Enable (\overline{OE}) is low, the 8-bit bus switch is on and port A is connected to Port B. When \overline{OE} is high, the switch is off and a high impedance exists between Port A and Port B.

To ensure the high-impedance state during power up or power down, \overline{OE} should be tied to V_{CC} through a pullup resistor.

FUNCTIONAL BLOCK DIAGRAM

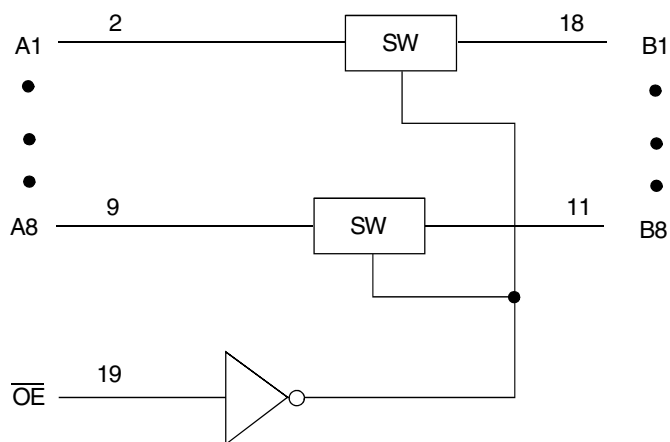

SIMPLIFIED SCHEMATIC, EACH SWITCH

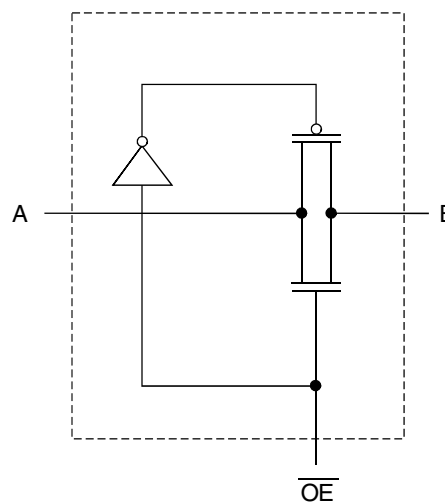

PIN CONFIGURATION

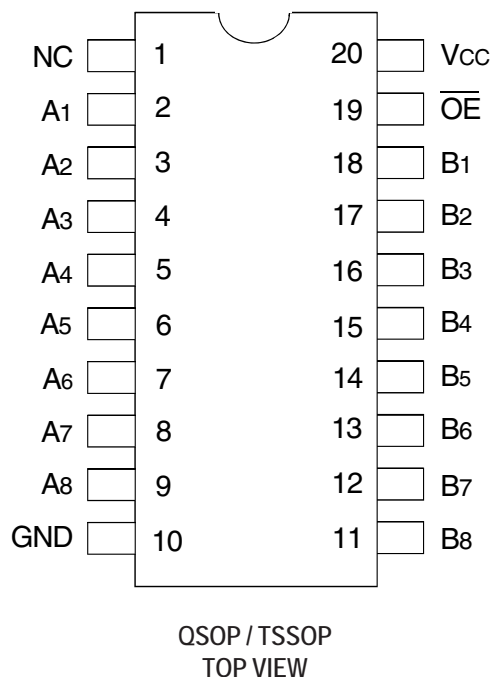

ABSOLUTE MAXIMUM RATINGS⁽¹⁾

| Symbol | Description | Max | Unit |
|------------------|---|--------------|------|
| V _{CC} | Supply Voltage Range | -0.5 to +4.6 | V |
| V _I | Input Voltage Range | -0.5 to +4.6 | V |
| | Continuous Channel Current | 128 | mA |
| I _{IK} | Input Clamp Current, V _{I/O} < 0 | -50 | mA |
| T _{STG} | Storage Temperature | -65 to +150 | °C |

NOTE:

1. Stresses greater than those listed under ABSOLUTE MAXIMUM RATINGS may cause permanent damage to the device. This is a stress rating only and functional operation of the device at these or any other conditions above those indicated in the operational sections of this specification is not implied. Exposure to absolute maximum rating conditions for extended periods may affect reliability.

PIN DESCRIPTION

| Pin Names | Description |
|-----------------|----------------------------|
| \overline{OE} | Output Enable (Active LOW) |
| A _x | Port A Inputs or Outputs |
| B _x | Port B Inputs or Outputs |

FUNCTION TABLE⁽¹⁾

| Input | Operation |
|-----------------|-----------------|
| \overline{OE} | |
| L | A Port = B Port |
| H | Isolation |

NOTE:

1. H = HIGH Voltage Level
L = LOW Voltage Level

OPERATING CHARACTERISTICS, T_A = 25°C⁽¹⁾

| Symbol | Parameter | Test Conditions | Min. | Max. | Unit |
|-----------------|----------------------------------|--------------------------------|------|------|------|
| V _{CC} | Supply Voltage | | 2.3 | 3.6 | V |
| V _{IH} | High-Level Control Input Voltage | V _{CC} = 2.3V to 2.7V | 1.7 | — | V |
| | | V _{CC} = 2.7V to 3.6V | 2 | — | |
| V _{IL} | Low-Level Control Input Voltage | V _{CC} = 2.3V to 2.7V | — | 0.7 | V |
| | | V _{CC} = 2.7V to 3.6V | — | 0.8 | |
| T _A | Operating Free-Air Temperature | | -40 | 85 | °C |

NOTE:

1. All unused control inputs of the device must be held at V_{CC} or GND to ensure proper device operation.

DC ELECTRICAL CHARACTERISTICS OVER OPERATING RANGE

Following Conditions Apply Unless Otherwise Specified:

Operating Conditions: $T_A = -40^{\circ}\text{C}$ to $+85^{\circ}\text{C}$

| Symbol | Parameter | Test Conditions | Min. | Typ. ⁽¹⁾ | Max. | Unit | |
|-----------------------|--|---|---------------------|---------------------|---------|---------------|----------|
| V_{IK} | Control Inputs, Data Inputs | $V_{CC} = 3\text{V}$, $I_I = -18\text{mA}$ | — | — | -1.2 | V | |
| I_I | Control Inputs | $V_{CC} = 3.6\text{V}$, $V_I = V_{CC}$ or GND | — | — | ± 1 | μA | |
| I_{OZ} | Data I/O | $V_{CC} = 3.6\text{V}$, $V_O = 0$ or 3.6V , switch disabled | — | — | 5 | μA | |
| I_{OFF} | | $V_{CC} = 0$, V_I or $V_O = 0$ to 3.6V | — | — | 50 | μA | |
| I_{CC} | | $V_{CC} = 3.6\text{V}$, $I_O = 0$, $V_I = V_{CC}$ or GND | — | — | 10 | μA | |
| $\Delta I_{CC}^{(2)}$ | Control Inputs | $V_{CC} = 3.6\text{V}$, one input at 3V , other inputs at V_{CC} or GND | — | — | 300 | μA | |
| C_I | Control Inputs | $V_I = 3\text{V}$ or 0 | — | 4 | — | pF | |
| $C_{I(OFF)}$ | | $V_O = 3\text{V}$ or 0 , $\overline{OE} = V_{CC}$ | — | 6 | — | pF | |
| $R_{ON}^{(3)}$ | $V_{CC} = 2.3\text{V}$ Typ. at $V_{CC} = 2.5\text{V}$ | $V_I = 0$ | $I_O = 64\text{mA}$ | — | 5 | 8 | Ω |
| | | | $I_O = 24\text{mA}$ | — | 5 | 8 | |
| | $V_I = 1.7\text{V}$ | $I_O = 15\text{mA}$ | — | 27 | 40 | | |
| | $V_{CC} = 3\text{V}$ | $V_I = 0$ | $I_O = 64\text{mA}$ | — | 5 | 7 | |
| | | | $I_O = 24\text{mA}$ | — | 5 | 7 | |
| | | $V_I = 2.4\text{V}$ | $I_O = 15\text{mA}$ | — | 10 | 15 | |

NOTES:

- Typical values are at $V_{CC} = 3.3\text{V}$, $+25^{\circ}\text{C}$ ambient.
- The increase in supply current is attributable to each current that is at the specified voltage level rather than V_{CC} or GND.
- This is measured by the voltage drop between the A and B terminals at the indicated current through the switch.

SWITCHING CHARACTERISTICS

| Symbol | Parameter | $V_{CC} = 2.5\text{V} \pm 0.2\text{V}$ | | $V_{CC} = 3.3\text{V} \pm 0.3\text{V}$ | | Unit |
|----------------|--|--|------|--|------|------|
| | | Min. | Max. | Min. | Max. | |
| $t_{PD}^{(1)}$ | Propagation Delay A to B or B to A | — | 0.15 | — | 0.25 | ns |
| t_{EN} | Output Enable Time \overline{OE} to A or B | 1 | 4.5 | 1 | 4.2 | ns |
| t_{DIS} | Output Disable Time \overline{OE} to A or B | 1 | 5 | 1 | 5 | ns |

- NOTE:
- The propagation delay is the calculated RC time constant of the typical on-state resistance of the switch and the specified load capacitance driven by an ideal voltage source (zero output impedance).

TEST CIRCUITS AND WAVEFORMS

TEST CONDITIONS

| Symbol | $V_{CC}^{(1)} = 3.3V \pm 0.3V$ | $V_{CC}^{(2)} = 2.5V \pm 0.2V$ | Unit |
|------------|--------------------------------|--------------------------------|------|
| V_{LOAD} | 6 | $2 \times V_{CC}$ | V |
| V_{IH} | 3 | V_{CC} | V |
| V_T | 1.5 | $V_{CC} / 2$ | V |
| V_{LZ} | 300 | 150 | mV |
| V_{HZ} | 300 | 150 | mV |
| C_L | 50 | 30 | pF |

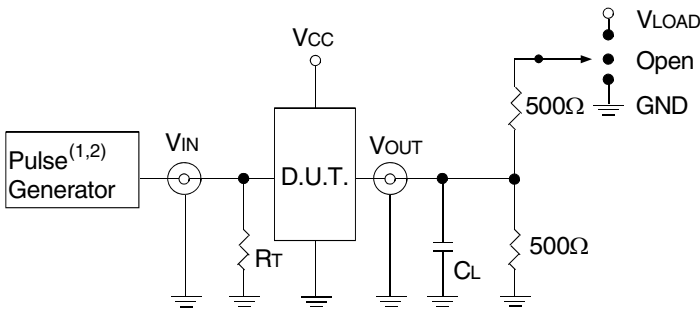

Test Circuits for All Outputs

DEFINITIONS:

C_L = Load capacitance: includes jig and probe capacitance.
 R_T = Termination resistance: should be equal to Z_{OUT} of the Pulse Generator.

NOTES:

1. Pulse Generator for All Pulses: Rate $\leq 10\text{MHz}$; $t_r \leq 2.5\text{ns}$; $t_f \leq 2.5\text{ns}$.
2. Pulse Generator for All Pulses: Rate $\leq 10\text{MHz}$; $t_r \leq 2\text{ns}$; $t_f \leq 2.5\text{ns}$.

SWITCH POSITION

| Test | Switch |
|-------------------|------------|
| t_{PLZ}/t_{PZL} | V_{LOAD} |
| t_{PHZ}/t_{PZH} | GND |
| t_{PD} | Open |

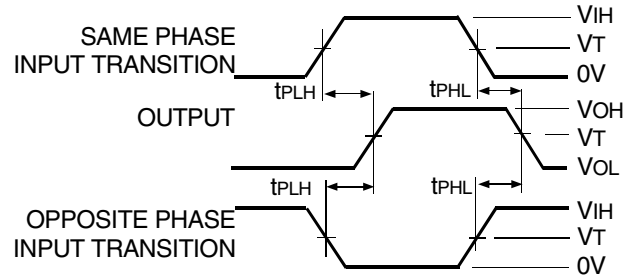

Propagation Delay

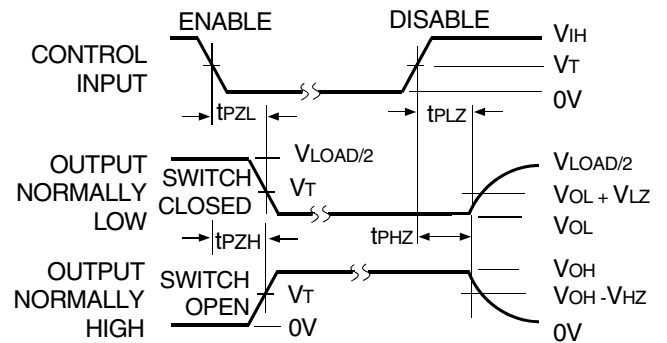

Enable and Disable Times

ORDERING INFORMATION

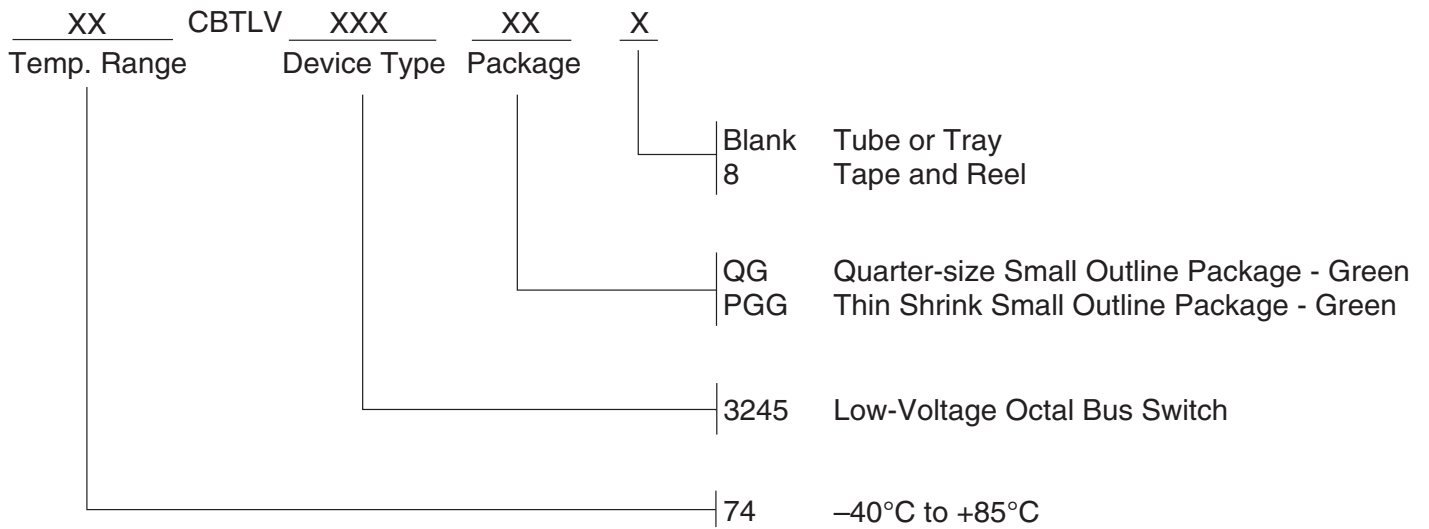

Datasheet Document History

12/18/2014 Pg. 5 Updated the ordering information by removing non RoHS part and by adding Tape and Reel information.



CORPORATE HEADQUARTERS
6024 Silver Creek Valley Road
San Jose, CA 95138

for SALES:
800-345-7015 or 408-284-8200
fax: 408-284-2775
www.idt.com

for Tech Support:
logichelp@idt.com

Компания «Life Electronics» занимается поставками электронных компонентов импортного и отечественного производства от производителей и со складов крупных дистрибьюторов Европы, Америки и Азии.

С конца 2013 года компания активно расширяет линейку поставок компонентов по направлению коаксиальный кабель, кварцевые генераторы и конденсаторы (керамические, пленочные, электролитические), за счёт заключения дистрибьюторских договоров

Мы предлагаем:

- Конкурентоспособные цены и скидки постоянным клиентам.
- Специальные условия для постоянных клиентов.
- Подбор аналогов.
- Поставку компонентов в любых объемах, удовлетворяющих вашим потребностям.
- Приемлемые сроки поставки, возможна ускоренная поставка.
- Доставку товара в любую точку России и стран СНГ.
- Комплексную поставку.
- Работу по проектам и поставку образцов.
- Формирование склада под заказчика.
- Сертификаты соответствия на поставляемую продукцию (по желанию клиента).
- Тестирование поставляемой продукции.
- Поставку компонентов, требующих военную и космическую приемку.
- Входной контроль качества.
- Наличие сертификата ISO.

В составе нашей компании организован Конструкторский отдел, призванный помогать разработчикам, и инженерам.

Конструкторский отдел помогает осуществить:

- Регистрацию проекта у производителя компонентов.
- Техническую поддержку проекта.
- Защиту от снятия компонента с производства.
- Оценку стоимости проекта по компонентам.
- Изготовление тестовой платы монтаж и пусконаладочные работы.



Тел: +7 (812) 336 43 04 (многоканальный)

Email: org@lifeelectronics.ru