

Si50122-Ax-EVB USER GUIDE

Description

Si50122-Ax is a high performance, crystal-less PCIe clock generator with internal CMEMS that can generate two 100 MHz HCSL and one 25 MHz LVCMOS clock outputs.

This document is intended to be used in conjunction with the Si50122-Ax-EVB, Si50122 device, and data sheet for the following tests:

- PCIe Gen 1, Gen 2, Gen 3 compliancy
- Power consumption test
- Jitter performance

The Si50122-Ax-EVB is used to evaluate the Si50122-Ax. Table 1 shows the device part number and corresponding evaluation board part number.

Table 1. Evaluation Board Orderable Part Number

Device Part Number	PCIe Compliant	Spread Spectrum	EVB Orderable Part Number
Si50122-A1-GM	Gen 1	No	Si50122-A3-EVB
Si50122-A2-GM	Gen 1	Yes	Si50122-A4-EVB
Si50122-A3-GM	Gen 1/2	No	Si50122-A3-EVB
Si50122-A4-GM	Gen 1/2	Yes	Si50122-A4-EVB
Si50122-A5-GM	Gen 1/2/3	No	Si50122-A5-EVB
Si50122-A6-GM	Gen 1/2/3	Yes	Si50122-A6-EVB

Si50122-Ax-EVB

1. Front Panel

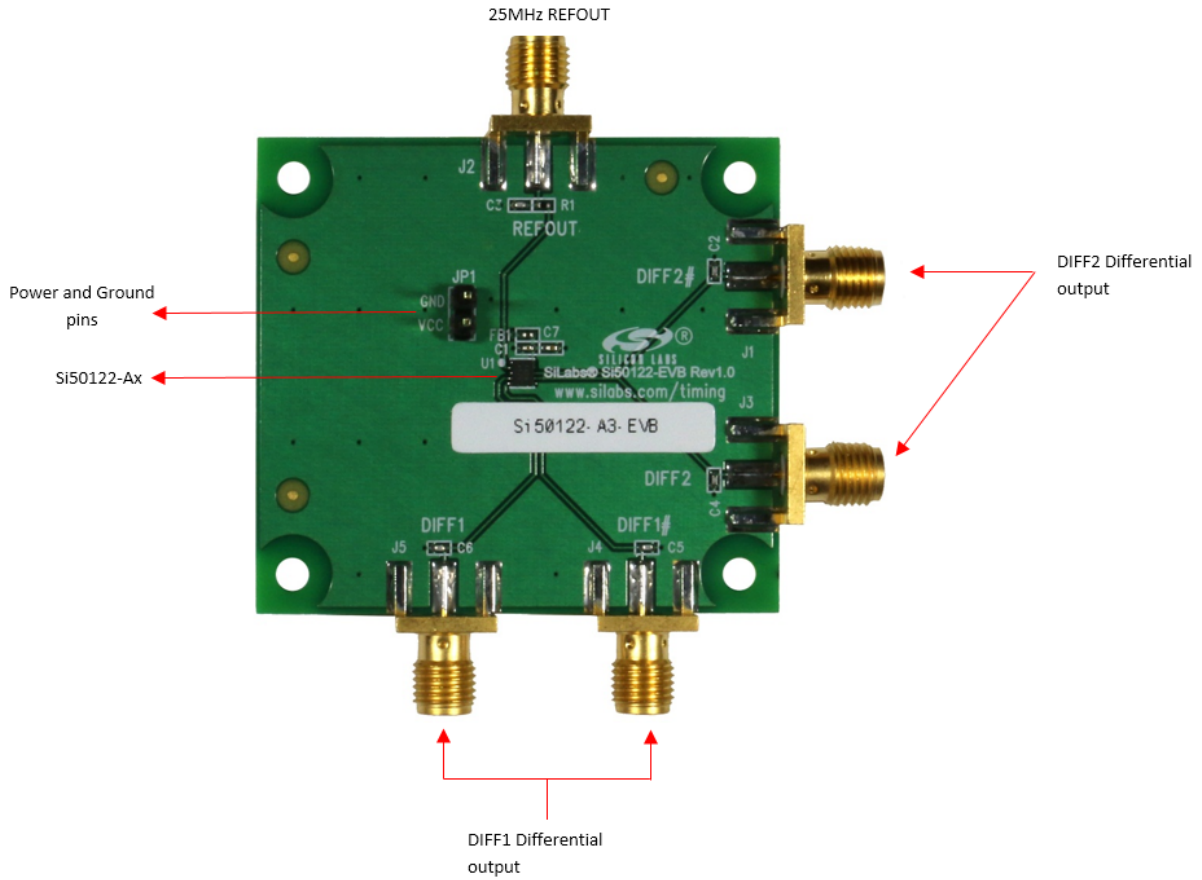

Figure 1. Evaluation Module Front Panel

To use Si50122-Ax-EVB:

1. Check to confirm that the device part number to be evaluated corresponds to the evaluation board – refer to Table 1.
2. Power up the EVB using the VCC and GND pins.
3. View and measure the outputs via the SMA connectors.

2. Schematics

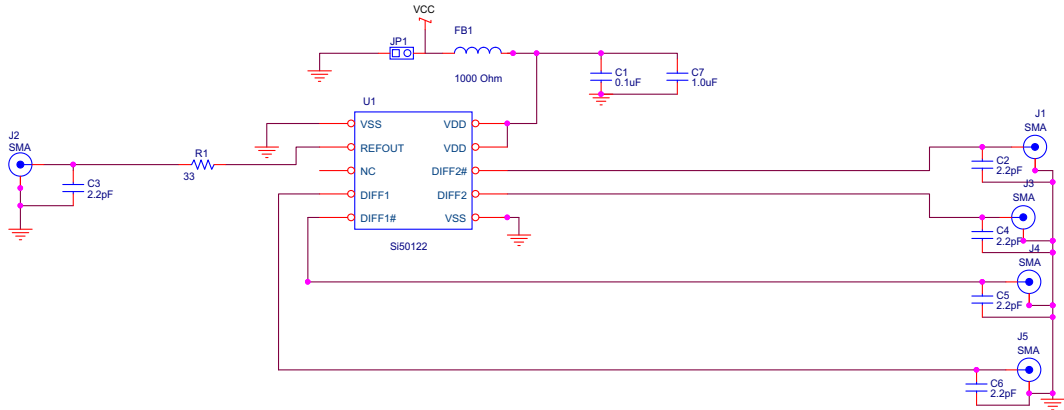

Figure 2. Si50122 Device Connection

Si50122-Ax-EVB

3. Bill of Materials

Item	Qty	Ref	Part	Rating	Tol	PCB Footprint	Manufacturer Part Number	Mfr
1	1	C1	0.1 μ F	16 V	\pm 10%	0402	C0402X7R160-104K	Venkel
2	4	C2	2.2 pF	50 V	\pm 0.1 pF	0402	C0402C0G500-2R2B	Venkel
		C3	2.2 pF					
		C4	2.2 pF					
		C5	2.2 pF					
		C6	2.2 pF					
3	2	JP1	HEADER 1x2	NA	NA	NA	TSW-102-07-G-S	Samtec
4	5	J1	SMA	NA	NA	NA	142-0701-801	Johnson Components
		J2	SMA					
		J3	SMA					
		J4	SMA					
		J5	SMA					
5	1	C7	1 μ F	6.3 V	\pm 10%	0402	C0402X5R6R3-105K	Venkel
6	1	R1	33 Ω	1/16 W	\pm 5%	0402	CR0402-16W-330J	Venkel
7	1	FB1	1000 Ω	200 mA		0402	BLM15AG102SN1	Murata
8	1	U1	Si50122	NA	NA	3X3 10-TDFN	Si50122	Si Labs

CONTACT INFORMATION

Silicon Laboratories Inc.

400 West Cesar Chavez

Austin, TX 78701

Tel: 1+(512) 416-8500

Fax: 1+(512) 416-9669

Toll Free: 1+(877) 444-3032

Please visit the Silicon Labs Technical Support web page:

<https://www.siliconlabs.com/support/pages/contacttechnicalsupport.aspx>

and register to submit a technical support request.

Patent Notice

Silicon Labs invests in research and development to help our customers differentiate in the market with innovative low-power, small size, analog-intensive mixed-signal solutions. Silicon Labs' extensive patent portfolio is a testament to our unique approach and world-class engineering team.

The information in this document is believed to be accurate in all respects at the time of publication but is subject to change without notice. Silicon Laboratories assumes no responsibility for errors and omissions, and disclaims responsibility for any consequences resulting from the use of information included herein. Additionally, Silicon Laboratories assumes no responsibility for the functioning of undescribed features or parameters. Silicon Laboratories reserves the right to make changes without further notice. Silicon Laboratories makes no warranty, representation or guarantee regarding the suitability of its products for any particular purpose, nor does Silicon Laboratories assume any liability arising out of the application or use of any product or circuit, and specifically disclaims any and all liability, including without limitation consequential or incidental damages. Silicon Laboratories products are not designed, intended, or authorized for use in applications intended to support or sustain life, or for any other application in which the failure of the Silicon Laboratories product could create a situation where personal injury or death may occur. Should Buyer purchase or use Silicon Laboratories products for any such unintended or unauthorized application, Buyer shall indemnify and hold Silicon Laboratories harmless against all claims and damages.

Silicon Laboratories and Silicon Labs are trademarks of Silicon Laboratories Inc.

Other products or brandnames mentioned herein are trademarks or registered trademarks of their respective holders.

Компания «Life Electronics» занимается поставками электронных компонентов импортного и отечественного производства от производителей и со складов крупных дистрибьюторов Европы, Америки и Азии.

С конца 2013 года компания активно расширяет линейку поставок компонентов по направлению коаксиальный кабель, кварцевые генераторы и конденсаторы (керамические, пленочные, электролитические), за счёт заключения дистрибьюторских договоров

Мы предлагаем:

- Конкуренеспособные цены и скидки постоянным клиентам.
- Специальные условия для постоянных клиентов.
- Подбор аналогов.
- Поставку компонентов в любых объемах, удовлетворяющих вашим потребностям.
- Приемлемые сроки поставки, возможна ускоренная поставка.
- Доставку товара в любую точку России и стран СНГ.
- Комплексную поставку.
- Работу по проектам и поставку образцов.
- Формирование склада под заказчика.
- Сертификаты соответствия на поставляемую продукцию (по желанию клиента).
- Тестирование поставляемой продукции.
- Поставку компонентов, требующих военную и космическую приемку.
- Входной контроль качества.
- Наличие сертификата ISO.

В составе нашей компании организован Конструкторский отдел, призванный помогать разработчикам, и инженерам.

Конструкторский отдел помогает осуществить:

- Регистрацию проекта у производителя компонентов.
- Техническую поддержку проекта.
- Защиту от снятия компонента с производства.
- Оценку стоимости проекта по компонентам.
- Изготовление тестовой платы монтаж и пусконаладочные работы.



Тел: +7 (812) 336 43 04 (многоканальный)

Email: org@lifeelectronics.ru