

Product Data Sheet

Amphenol® Industrial Amphe-PPM Quick Disconnect Connectors

No. 195

The Amphe-PPM is a rapid mate, push/pull connector which provides positive mating in limited space and ease of use. The design features of the Amphe-PPM allow consumers to save cost in space savings and in installation.

Amphe-PPM, the high performance signal and power interconnection solution, is ideally suited to many commercial and industrial applications including, but not limited to:

- Medical Equipment
- Instrumentation/Test & Measurement
- Communication Equipment

The Amphe-PPM continues Amphenol's commitment of providing new products to meet customer and market demands for new emerging technologies and advancing applications.



Features and Benefits of Amphe-PPM Connectors

- Push/pull rapid mate connector system - high performance of 500 + mating cycles
- Sealed or non-sealed connector versions -
NON-SEALED VERSION:
 - Available in 12mm and 16mm shell sizes
 - From 2 up to 12 contacts of 1.0mm to 2.5mm diameter (see back side for insert arrangement charts)
 - Jam nut receptacle and straight plug are available with a rubber boot or standard cable clamp rear accessory
 - Non-reflective nickel or black epoxy finish
 - IP55 rated
- SEALED VERSION:
 - Available in 10mm, 12mm, 16mm and 18mm shell sizes
 - From 2 up to 14 contacts of 0.8mm to 2.5mm diameter (see back side for insert arrangement charts)
 - Jam nut receptacle and straight plug come with jacketed cable PG sealing gland
 - Non-reflective nickel finish only
 - IP67 rated
- Three shell styles available: box mount and jam nut receptacles and a straight plug
- Designed to IEC 61984
- Inserts have a UL94V-0 flammability rating
- Operating temperature: -40° to 100°C
- Solder contacts standard, crimp by special request
- Non-magnetic product standard

Notice: Specifications are subject to change without notice. Contact your nearest Amphenol Corporation Sales Office for the latest specifications. All statements, information and data given herein are believed to be accurate and reliable but are presented without guarantee, warranty, or responsibility of any kind, expressed or implied. Statements or suggestions concerning possible use of our products are made without representation or warranty that any such use is free of patent infringement and are not recommendations to infringe any patent. The user should assume that all safety measures are indicated or that other measures may not be required. Specifications are typical and may not apply to all connectors.

AMPHENOL is a registered trademark of Amphenol Corporation.

©2006 Amphenol Corporation

Amphenol

Printed in U.S.A. 4/2006

HOW TO ORDER

Amphe-PPM Sealed Connectors

APS _____
 designates Amphe-PPM Sealed Series Connectors

D _____
 Shell Size: _____
 C designates 10mm shell size
 D designates 12mm shell size
 E designates 16mm shell size
 F designates 18mm shell size

S _____
 Contact Type: _____
 P designates pin contacts
 S designates socket contacts

A _____
 Insert Arrangement Designator _____
 See Insert Arrangement Tables 1, 2, 3, 4

6 _____
 Sealing Range:

Series	Diameters in mm			
	E1		E2	
C	N/A	N/A	3 - 6.5	PG7
D	3 - 6.5	PG7	4 - 8	PG9
E	4 - 8	PG9	7 - 12	PG13.5
F	7 - 12	PG13.5	10 - 14	PG16

E1 _____
 Shell Style:
 2 designates square flange receptacle
 6 designates straight plug
 7 designates jam nut receptacle

Table 1
Shell Size "C" 10mm

Insert Arrangement	Contact Diameter (mm)	No. of Contacts
A	1	2
B	1	3
C	0.8	4
D	0.8	5

Table 2
Shell Size "D" 12mm

Insert Arrangement	Contact Diameter (mm)	No. of Contacts
A	1.6	2
B	1	3
C	1	4
D	1	5
E	1	6
F	1	7

Table 3
Shell Size "E" 16mm

Insert Arrangement	Contact Diameter (mm)	No. of Contacts
A	1.5	2
B	2.5	2
C	1	3
D	1.5	3
E	1	4
F	1.5	4
G	1	5
H	1	7
I	1	9
J	1	12

Table 4
Shell Size "F" 18mm

Insert Arrangement	Contact Diameter (mm)	No. of Contacts
A	2.5	3
B	1.5	5
C	1.5 (3 contacts), 1 (5 contacts)	8
D	1	5

HOW TO ORDER

Amphe-PPM Non-Sealed Connectors

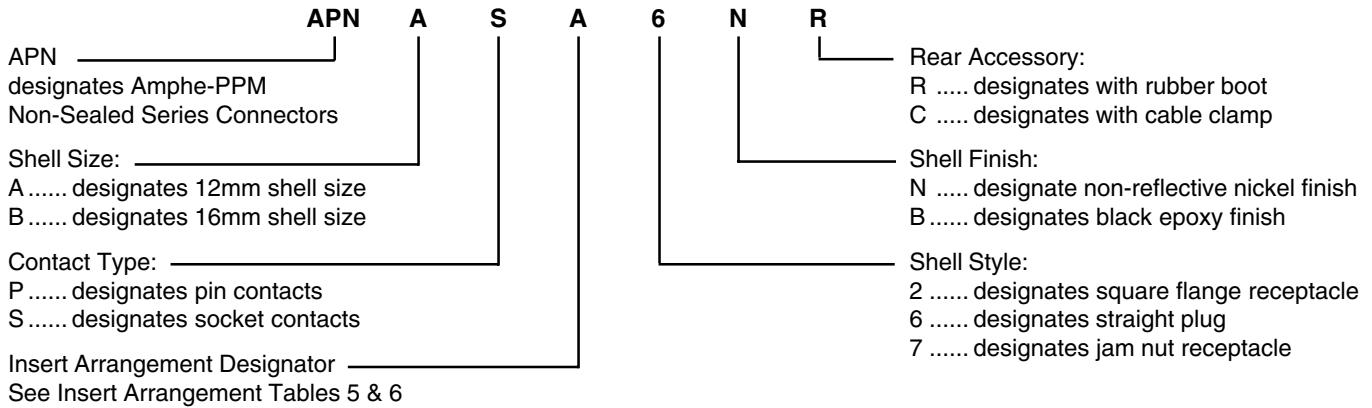

Table 5
Shell Size "A" 12mm

Insert Arrangement	Contact Diameter (mm)	No. of Contacts
A	1.6	2
B	1	3
C	1	4
D	1	5
E	1	6
F	1	7

Table 6
Shell Size "B" 16mm

Insert Arrangement	Contact Diameter (mm)	No. of Contacts
A	1.5	2
B	2.5	2
C	1	3
D	1.5	3
E	1	4
F	1.5	4
G	1	5
H	1	7
I	1	9
J	1	12

For additional information on the Amphe-PPM connectors consult Amphenol Industrial Operations.

For further information on your individual application requirements, contact:

Amphenol Corporation
Amphenol Industrial Operations
40-60 Delaware Avenue
Sidney, NY 13838-1395
Phone: 1-607-563-5011 Fax: 1-607-563-5351
Internet: www.amphenol-industrial.com

Компания «Life Electronics» занимается поставками электронных компонентов импортного и отечественного производства от производителей и со складов крупных дистрибьюторов Европы, Америки и Азии.

С конца 2013 года компания активно расширяет линейку поставок компонентов по направлению коаксиальный кабель, кварцевые генераторы и конденсаторы (керамические, пленочные, электролитические), за счёт заключения дистрибьюторских договоров

Мы предлагаем:

- Конкурентоспособные цены и скидки постоянным клиентам.
- Специальные условия для постоянных клиентов.
- Подбор аналогов.
- Поставку компонентов в любых объемах, удовлетворяющих вашим потребностям.
- Приемлемые сроки поставки, возможна ускоренная поставка.
- Доставку товара в любую точку России и стран СНГ.
- Комплексную поставку.
- Работу по проектам и поставку образцов.
- Формирование склада под заказчика.
- Сертификаты соответствия на поставляемую продукцию (по желанию клиента).
- Тестирование поставляемой продукции.
- Поставку компонентов, требующих военную и космическую приемку.
- Входной контроль качества.
- Наличие сертификата ISO.

В составе нашей компании организован Конструкторский отдел, призванный помогать разработчикам, и инженерам.

Конструкторский отдел помогает осуществить:

- Регистрацию проекта у производителя компонентов.
- Техническую поддержку проекта.
- Защиту от снятия компонента с производства.
- Оценку стоимости проекта по компонентам.
- Изготовление тестовой платы монтаж и пусконаладочные работы.



Тел: +7 (812) 336 43 04 (многоканальный)
Email: org@lifeelectronics.ru