

## DUAL HIGH SPEED SINGLE SUPPLY OPERATIONAL AMPLIFIER

### ■FEATURES

- Low Input Offset Voltage 3.5mV max.
- Low Input Offset Voltage Drift 3.5 $\mu$ V/ $^{\circ}$ C
- High Slew Rate 8.5V/ $\mu$ s
- High Unity Gain Frequency 3.5MHz
- Single Supply 3V~36V
- Operating Temperature Range -40 $^{\circ}$ C~+125 $^{\circ}$ C
- Low input voltage around GND level
- Unity-Gain Stable ( $C_L=1000$ pF)
- Operating Current (All amplifiers) 4.3mA
- No Phase Reversal
- High EMI Immunity
- Output Short-Circuit Protection
- Package

NJM842                      SOP8, SSOP8, VSP8

### ■GENERAL DESCRIPTION

The NJM842 is a high slew rate, single supply Dual operational amplifier.

The NJM842 is suitable for active filter, buffer, and current control/detect circuits of inverter and motor driver.

### ■APPLICATIONS

- Current Sensor
- Buffer Application Amplifier
- Active filter
- Battery Application

### ■PACKAGE OUTLINE

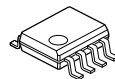

**NJM842G**  
(SOP8)

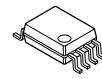

**NJM842V**  
(SSOP8)



**NJM842R**  
(VSP8)

### ■PIN CONFIGURATION

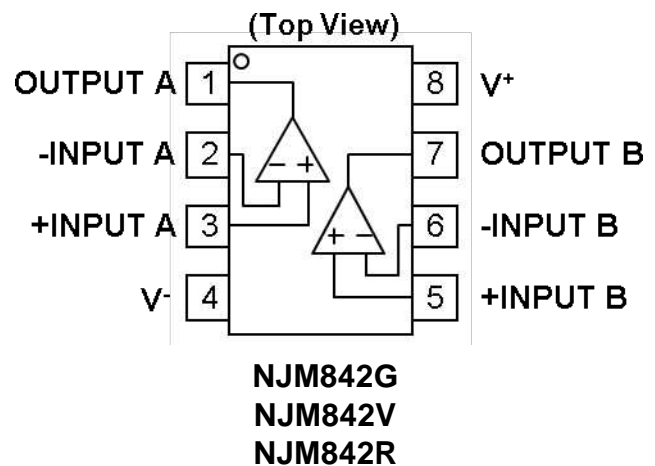

## ■ABSOLUTE MAXIMUM RATINGS (Ta=25°C, unless otherwise noted.)

PARAMETER	SYMBOL	RATING	UNIT
Supply Voltage	$V^+ - V^-$	38 <sup>(5)</sup>	V
Differential Input Voltage <sup>(1)</sup>	$V_{ID}$	$\pm 36$ <sup>(2)</sup>	V
Input Voltage <sup>(2)</sup>	$V_{IN}$	$V^- - 0.3$ to $V^+ + 36$	V
Output Terminal Input Voltage	$V_O$	$V^- - 0.3$ to $V^+ + 0.3V$	V
Power Dissipation <sup>(3)</sup>	$P_D$	(2-layer / 4-layer)	mW
SOP8		780 / 1200	
SSOP8		510 / 650	
VSP8		600 / 810	
Output Short-Circuit Duration <sup>(4)</sup>		infinite	
Operating Temperature Range	$T_{opr}$	-40 to +125	°C
Storage Temperature Range	$T_{stg}$	-55 to +150	°C

(1) Differential voltage is the voltage difference between +INPUT and -INPUT.

(2) Input voltage should be allowed to apply to the input terminal independent of the magnitude of  $V^+$ . The normal operation will establish when any input is within the Common Mode Voltage Range of electrical characteristics.

(3) Power dissipation is the power that can be consumed by the IC at Ta=25°C, and is the typical measured value based on JEDEC condition. When using the IC over Ta=25°C subtract the value [mW/°C]=PD/(Tstg(MAX)-25) per temperature.

2-layer: EIA/JEDEC STANDARD Test board (76.2x114.3x1.6mm, 2layers, FR-4) mounting

4-layer: EIA/JEDEC STANDARD Test board (76.2x114.3x1.6mm, 4layers, FR-4) mounting

(4) Temperature and/or supply voltages must be limited to ensure the maximum dissipation rating is not exceeded.

(5) Supply Voltage is the voltage difference between  $V^+$  and  $V^-$ .

Figure1. Power Dissipation vs. Temperature

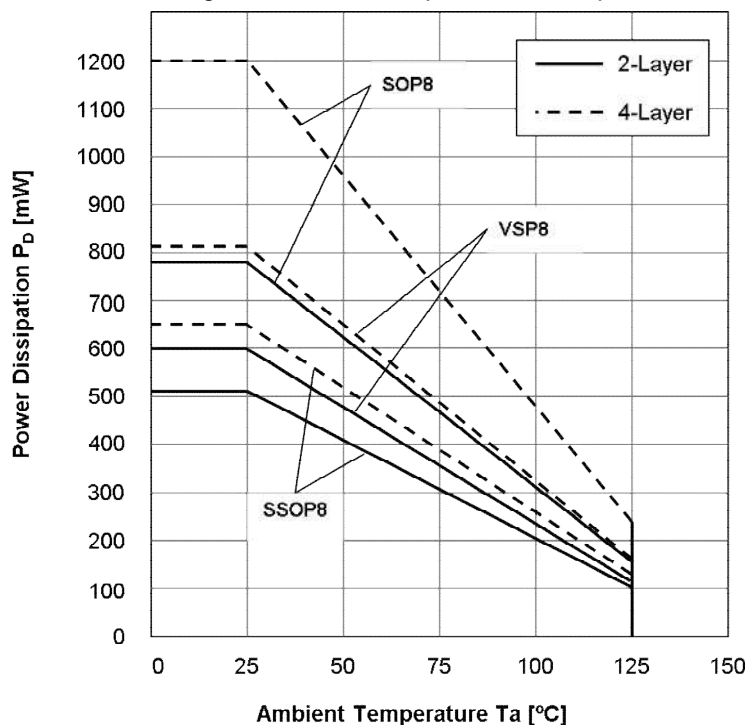

## ■RECOMMENDED OPERATING CONDITIONS (Ta=25°C)

PARAMETER	Supply Voltage	UNIT
Supply Voltage	+3 to +36 ( $\pm 1.5$ to $\pm 18$ )	V

**■ELECTRICAL CHARACTERISTICS** ( $V^+=+15V$ ,  $V^-=-15V$ ,  $V_{CM}=0V$ ,  $T_a=25^\circ C$  unless otherwise noted)

PARAMETER	SYMBOL	TEST CONDITION	MIN.	TYP.	MAX.	UNIT
<b>INPUT CHARACTERISTICS</b>						
Input Offset Voltage	$V_{IO}$	$R_S=50\Omega$ , $V_{CM}=0V$	-	0.8	3.5	mV
Input Offset Voltage Drift	$\Delta V_{IO}/\Delta T$	$T_a=-40^\circ C \sim +125^\circ C$	-	3.5	-	$\mu V/^\circ C$
Input Bias Current	$I_B$		-	120	500	nA
Input Offset Current	$I_{IO}$		-	6	75	nA
Open-Loop Voltage Gain	$A_V$	$V_O=\pm 10V$ , $R_L=2k\Omega$ to $0V$	88	110	-	dB
Common Mode Rejection Ratio	CMR	$V_{ICM}=-15V$ to $13.2V$	70	86	-	dB
Common Mode Input Voltage Range	$V_{ICM}$	CMR $\geq 70$ dB	$V^-$	-	$V^+-1.8$	V
<b>OUTPUT CHARACTERISTICS</b>						
High-level Output Voltage	$V_{OH}$	$R_L=10k\Omega$ to $0V$	13.7	14	-	V
		$R_L=2k\Omega$ to $0V$	13.5	14	-	
Low-level Output Voltage	$V_{OL}$	$R_L=10k\Omega$ to $0V$	-	-14.3	-13.7	V
		$R_L=2k\Omega$ to $0V$	-	-13.8	-13.5	
Output Source Current	$I_{SOURCE}$	$V_O=0V$ , +Input= $+1V$ , -Input= $0V$	10	40	-	mA
Output Sink Current	$I_{SINK}$	$V_O=0V$ , +Input= $0V$ , -Input= $+1V$	10	45	-	mA
<b>POWER SUPPLY</b>						
Supply Current (All amplifiers)	$I_{SUPPLY}$	No Signal, $R_L=\infty$	-	4.3	5.5	mA
Supply Voltage Rejection Ratio	SVR	$V^+/V^-=\pm 1.5V$ to $\pm 18V$ , $V_{ICM}=0V$	70	93	-	dB
<b>AC CHARACTERISTICS</b>						
Gain Bandwidth Product	GBW	$R_L=2k\Omega$ to $0V$ , $f=100kHz$	-	3.5	-	MHz
Slew Rate	SR	$G_V=0dB$ , $R_L=2k\Omega$ to $0V$ , $C_L=20pF$ , $V_{in}=-10V$ to $+10V$	-	8.5	-	V/ $\mu s$
Phase Margin	$\phi_M$	$R_L=2k\Omega$ to $0V$ , $C_L=20pF$	-	90	-	deg
		$R_L=2k\Omega$ to $0V$ , $C_L=330pF$	-	70	-	
Gain Margin	GM	$R_L=2k\Omega$ to $0V$ , $C_L=20pF$	-	9	-	dB
		$R_L=2k\Omega$ to $0V$ , $C_L=330pF$	-	8	-	
<b>NOISE, THD</b>						
Equivalent Input Noise Voltage	$e_n$	$f=1kHz$	-	32	-	nV/ $\sqrt{Hz}$
Total Harmonic Distortion + Noise	THD+N	$G_V=20dB$ , $R_L=2k\Omega$ to $0V$ , $C_L=20pF$ , $f=1kHz$ , $V_O=15V_{PP}$	-	0.003	-	%
Channel Separation	CS	$f=10kHz$ , Equivalent Input value	-	120	-	dB

**■ ELECTRICAL CHARACTERISTICS** ( $V^+=+5V$ ,  $V^-=0V$ ,  $V_{CM}=2.5V$ ,  $T_a=25^\circ C$  unless otherwise noted)

PARAMETER	SYMBOL	TEST CONDITION	MIN.	TYP.	MAX.	UNIT
<b>INPUT CHARACTERISTICS</b>						
Input Offset Voltage	$V_{IO}$	$R_S=50\Omega$ , $V_{CM}=V^+/2$ , $V_O=V^+/2$	-	0.5	3.5	mV
Input Offset Voltage Drift	$\Delta V_{IO}/\Delta T$	$T_a=-40^\circ C \sim +125^\circ C$	-	2.5	-	$\mu V/^\circ C$
Input Bias Current	$I_B$	$V_{CM}=V^+/2$ , $V_O=V^+/2$	-	140	500	nA
Input Offset Current	$I_{IO}$	$V_{CM}=V^+/2$ , $V_O=V^+/2$	-	6	75	nA
Open-Loop Voltage Gain	$A_v$	$V_O=1.5V$ to $3.5V$ , $R_L=2k\Omega$ to $0V$	88	110	-	dB
Common Mode Rejection Ratio	CMR	$V_{CM}=0V$ to $3.2V$	70	80	-	dB
Common Mode Input Voltage Range	$V_{ICM}$	CMR $\geq 70$ dB	$V^-$	-	$V^+-1.8$	V
<b>OUTPUT CHARACTERISTICS</b>						
High-level Output Voltage	$V_{OH}$	$R_L=2k\Omega$ to $0V$	3.7	4	-	V
Low-level Output Voltage	$V_{OL}$	$R_L=2k\Omega$ to $0V$	-	0	0	V
Output Source Current	$I_{SOURCE}$	$V_O=0V$ , +Input= $+1V$ , -Input= $0V$	10	30	-	mA
Output Sink Current	$I_{SINK}$	$V_O=5V$ , +Input= $0V$ , -Input= $+1V$	10	30	-	mA
<b>POWER SUPPLY</b>						
Supply Current (All amplifier)	$I_{SUPPLY}$	No Signal, $R_L=\infty$	-	3.3	4.5	mA
<b>AC CHARACTERISTICS</b>						
Gain Bandwidth Product	GBW	$R_L=2k\Omega$ to $0V$ , $f=100kHz$	-	3.5	-	MHz
Slew Rate	SR	$G_v=0dB$ , $R_L=2k\Omega$ to $0V$ , $C_L=20pF$ , $V_{in}=+0.5V$ to $+3V$	-	7	-	V/ $\mu s$
Phase Margin	$\phi_M$	$R_L=2k\Omega$ to $0V$ , $C_L=20pF$	-	80	-	deg
		$R_L=2k\Omega$ to $0V$ , $C_L=330pF$	-	55	-	
Gain Margin	GM	$R_L=2k\Omega$ to $0V$ , $C_L=20pF$	-	9	-	dB
		$R_L=2k\Omega$ to $0V$ , $C_L=330pF$	-	7	-	
<b>NOISE, THD</b>						
Equivalent Input Noise Voltage	$e_n$	$f=1kHz$	-	30	-	nV/ $\sqrt{Hz}$

■ PACKAGE DIMENSIONS

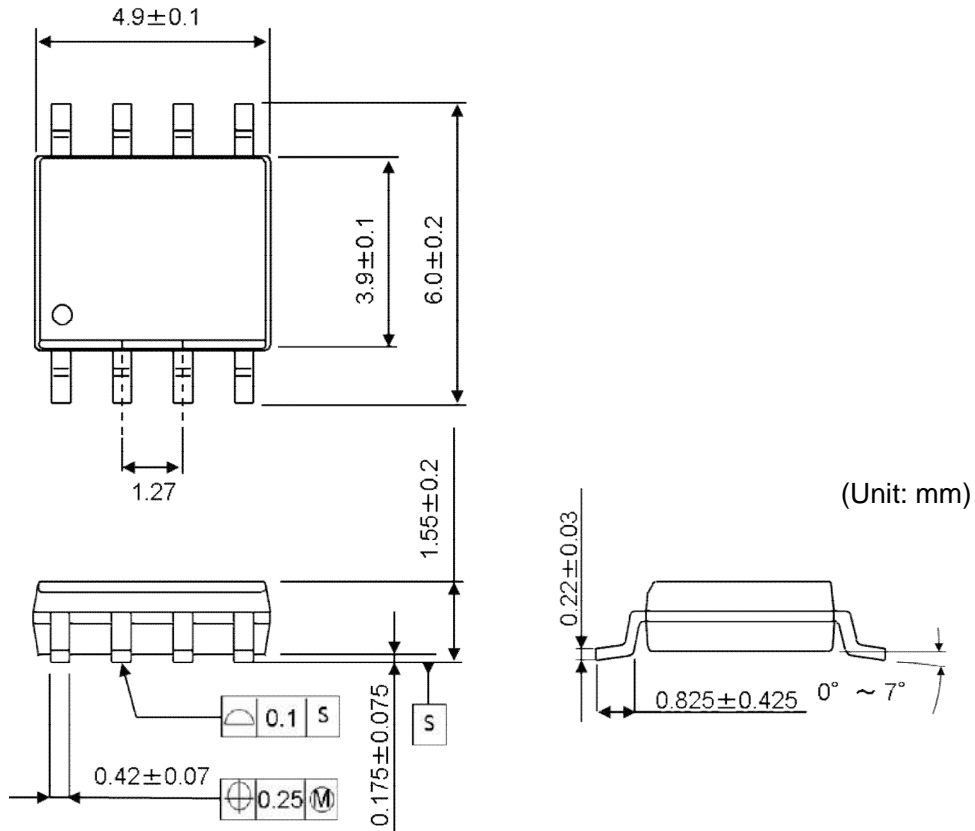

SOP8 Package

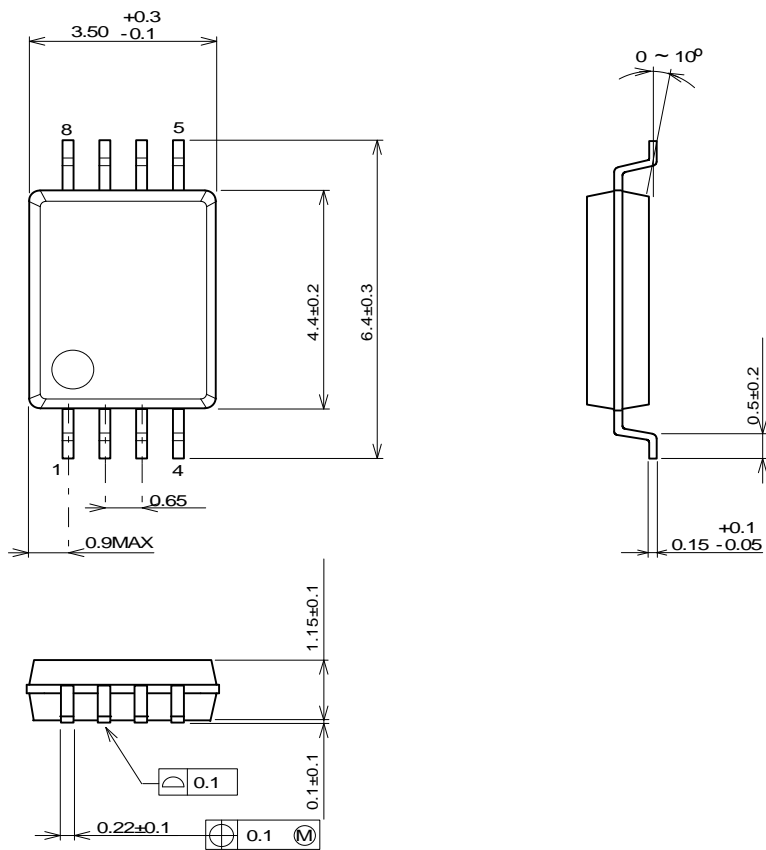

SSOP8 Package

■ PACKAGE DIMENSIONS

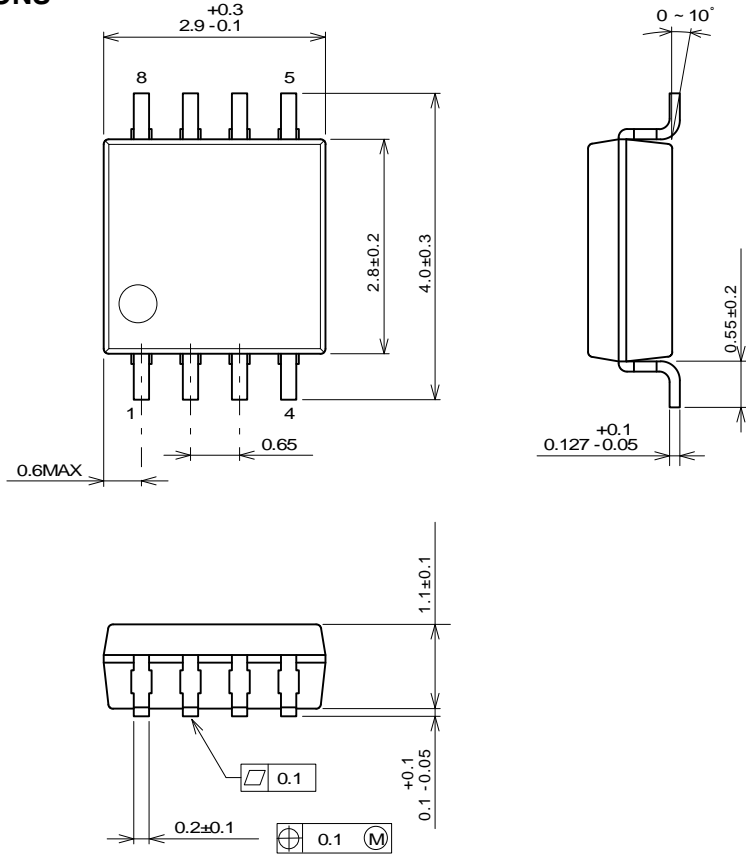

(Unit: mm)

**MSOP8 (TVSP8) JEDEC MO-187-DA / thin type Package**

[CAUTION]  
 The specifications on this data book are only given for information, without any guarantee as regards either mistakes or omissions. The application circuits in this data book are described only to show representative usages of the product and not intended for the guarantee or permission of any right including the industrial rights.

# Mouser Electronics

Authorized Distributor

Click to View Pricing, Inventory, Delivery & Lifecycle Information:

[NJR:](#)

[NJM842G-TE2](#) [NJM842V-TE1](#) [NJM842R-TE1](#)

Компания «Life Electronics» занимается поставками электронных компонентов импортного и отечественного производства от производителей и со складов крупных дистрибьюторов Европы, Америки и Азии.

С конца 2013 года компания активно расширяет линейку поставок компонентов по направлению коаксиальный кабель, кварцевые генераторы и конденсаторы (керамические, пленочные, электролитические), за счёт заключения дистрибьюторских договоров

Мы предлагаем:

- Конкурентоспособные цены и скидки постоянным клиентам.
- Специальные условия для постоянных клиентов.
- Подбор аналогов.
- Поставку компонентов в любых объемах, удовлетворяющих вашим потребностям.
- Приемлемые сроки поставки, возможна ускоренная поставка.
- Доставку товара в любую точку России и стран СНГ.
- Комплексную поставку.
- Работу по проектам и поставку образцов.
- Формирование склада под заказчика.
- Сертификаты соответствия на поставляемую продукцию (по желанию клиента).
- Тестирование поставляемой продукции.
- Поставку компонентов, требующих военную и космическую приемку.
- Входной контроль качества.
- Наличие сертификата ISO.

В составе нашей компании организован Конструкторский отдел, призванный помогать разработчикам, и инженерам.

Конструкторский отдел помогает осуществить:

- Регистрацию проекта у производителя компонентов.
- Техническую поддержку проекта.
- Защиту от снятия компонента с производства.
- Оценку стоимости проекта по компонентам.
- Изготовление тестовой платы монтаж и пусконаладочные работы.



Тел: +7 (812) 336 43 04 (многоканальный)  
Email: [org@lifeelectronics.ru](mailto:org@lifeelectronics.ru)