

EVALUATION KIT
AVAILABLE

MAXIM

2x4-Channel, Simultaneous-Sampling 12-Bit ADCs

MAX115/MAX116

General Description

The MAX115/MAX116 are high-speed, multichannel, 12-bit data-acquisition systems (DAS) with simultaneous track/holds (T/Hs). These devices contain a 12-bit, 2 μ s, successive-approximation analog-to-digital converter (ADC), a +2.5V reference, a buffered reference input, and a bank of four simultaneous-sampling T/H amplifiers that preserve the relative phase information of the sampled inputs. The MAX115/MAX116 have two multiplexed inputs for each T/H, allowing a total of eight inputs. In addition, the converter is overvoltage tolerant to ± 17 V. A fault condition on any channel will not damage the IC. Available input ranges are ± 5 V (MAX115) and ± 2.5 V (MAX116).

The parallel interface's data access and bus release timing specifications are compatible with most popular digital signal processors and 16-bit/32-bit microprocessors. The MAX115/MAX116 conversion results can be accessed without resorting to wait-states.

Applications

Multiphase Motor Control
Power-Grid Synchronization
Power-Factor Monitoring
Digital Signal Processing
Vibration and Waveform Analysis

Pin Configuration

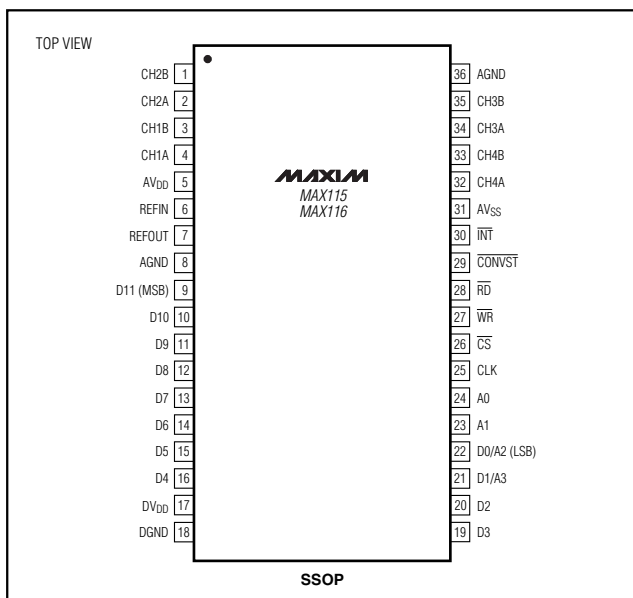

Features

- ◆ Four Simultaneous-Sampling T/H Amplifiers with Two Multiplexed Inputs (Eight Single-Ended Inputs Total)
- ◆ 2 μ s Conversion Time per Channel
- ◆ Throughput: 390ksps (1 Channel)
218ksps (2 Channels)
152ksps (3 Channels)
116ksps (4 Channels)
- ◆ Input Range: ± 5 V (MAX115)
 ± 2.5 V (MAX116)
- ◆ Fault-Protected Input Multiplexer (± 17 V)
- ◆ Internal +2.5V or External Reference Operation
- ◆ Programmable On-Board Sequencer
- ◆ High-Speed Parallel DSP Interface
- ◆ Internal 10MHz Clock

Ordering Information

| PART | TEMP. RANGE | PIN-PACKAGE |
|-----------|----------------|-------------|
| MAX115CAX | 0°C to +70°C | 36 SSOP |
| MAX115EAX | -40°C to +85°C | 36 SSOP |
| MAX116CAX | 0°C to +70°C | 36 SSOP |
| MAX116EAX | -40°C to +85°C | 36 SSOP |

Typical Operating Circuit

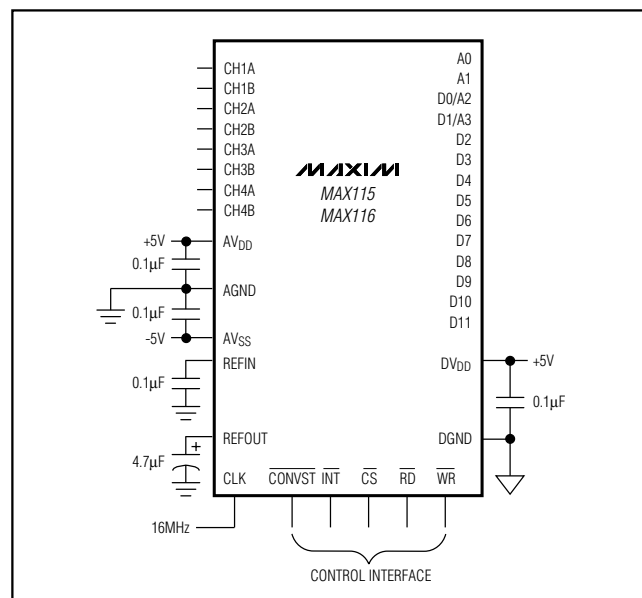

MAXIM

Maxim Integrated Products 1

For price, delivery, and to place orders, please contact Maxim Distribution at 1-888-629-4642, or visit Maxim's website at www.maxim-ic.com.

2x4-Channel, Simultaneous-Sampling 12-Bit ADCs

ABSOLUTE MAXIMUM RATINGS

| | | |
|--------------------------------------|------------------------------------|---|
| AV _{DD} to AGND | -0.3V to 6V | Continuous Power Dissipation (T _A = +70°C) |
| AV _{SS} to AGND | 0.3V to -6V | 36-Pin SSOP (derate 11.8mW/°C above +70°C) |
| DV _{DD} to DGND | -0.3V to 6V | Operating Temperature Ranges |
| AGND to DGND | -0.3V to 0.3V | MAX115_CAX/MAX116_CAX |
| CH_ _ to AGND | ±17V | MAX115_EAX/MAX116_EAX |
| REFIN, REFOUT to AGND | -0.3V to 6V | Junction Temperature |
| Digital Inputs/Outputs to DGND | -0.3V to (DV _{DD} + 0.3V) | Storage Temperature Range |
| | | Lead Temperature (soldering, 10s)..... |

Stresses beyond those listed under "Absolute Maximum Ratings" may cause permanent damage to the device. These are stress ratings only, and functional operation of the device at these or any other conditions beyond those indicated in the operational sections of the specifications is not implied. Exposure to absolute maximum rating conditions for extended periods may affect device reliability.

ELECTRICAL CHARACTERISTICS

(AV_{DD} = +5V ±5%, AV_{SS} = -5V ±5%, DV_{DD} = +5V ±5%, V_{REFIN} = +2.5V (external reference), AGND = DGND = 0, 4.7μF capacitor from REFOUT to AGND, 0.1μF capacitor from REFIN to AGND, f_{CLK} = 16MHz, external clock, 50% duty cycle. T_A = T_{MIN} to T_{MAX}, unless otherwise noted. Typical values are at T_A = +25°C.)

| PARAMETER | SYMBOL | CONDITIONS | MIN | TYP | MAX | UNITS |
|--|--------|----------------------|---|-----|-----|-------|
| DC ACCURACY (Note 1) | | | | | | |
| Resolution | N | All channels | 12 | | | Bits |
| Integral Nonlinearity (Note 2) | INL | | | 0.6 | ±1 | LSB |
| Differential Nonlinearity | DNL | | | 0.6 | ±1 | LSB |
| Bipolar Zero Error | | MAX115 | T _A = +25°C | ±5 | ±15 | mV |
| | | | T _A = T _{MIN} to T _{MAX} | | ±30 | |
| | | MAX116 | T _A = +25°C | ±5 | ±10 | |
| | | | T _A = T _{MIN} to T _{MAX} | | ±18 | |
| Bipolar Zero-Error Match | | Between all channels | | 2 | 5 | mV |
| Zero-Code Tempco | | MAX115 | | 180 | | μV/°C |
| | | MAX116 | | 90 | | |
| Gain Error | | MAX115 | T _A = +25°C | ±5 | ±15 | mV |
| | | | T _A = T _{MIN} to T _{MAX} | | ±25 | |
| | | MAX116 | T _A = +25°C | ±5 | ±10 | |
| | | | T _A = T _{MIN} to T _{MAX} | | ±18 | |
| Gain Error Match | | | | 2 | 5 | mV |
| Gain Error Tempco | | MAX115 | | 120 | | μV/°C |
| | | MAX116 | | 60 | | |
| DYNAMIC PERFORMANCE (f _{CLK} = 16MHz, f _{IN} = 10.06kHz) (Notes 1, 3) | | | | | | |
| Signal-to-Noise Ratio | SNR | (Note 4) | 69 | | | dB |
| Total Harmonic Distortion | THD | (Notes 4, 5) | | | -80 | dB |
| Spurious-Free Dynamic Range | SFDR | (Note 4) | 80 | | | dB |
| Channel-to-Channel Isolation | | (Note 6) | | 80 | | dB |

2x4-Channel, Simultaneous-Sampling 12-Bit ADCs

MAX115/MAX116

ELECTRICAL CHARACTERISTICS (continued)

(AVDD = +5V ±5%, AVSS = -5V ±5%, DVDD = +5V ±5%, VREFIN = +2.5V (external reference), AGND = DGND = 0, 4.7µF capacitor from REFOUT to AGND, 0.1µF capacitor from REFIN to AGND, fCLK = 16MHz, external clock, 50% duty cycle. TA = TMIN to TMAX, unless otherwise noted. Typical values are at TA = +25°C.)

| PARAMETER | SYMBOL | CONDITIONS | MIN | TYP | MAX | UNITS |
|---|---------|-------------------------------|-------|------|-------|--------|
| ANALOG INPUT | | | | | | |
| Input Voltage Range | VIN | MAX115 | | | ±5 | V |
| | | MAX116 | | | ±2.5 | |
| Input Current | IIN | MAX115 (-5V to +5V range) | | | ±625 | µA |
| | | MAX116 (-2.5V to +2.5V range) | | | ±15 | |
| Input Capacitance | CIN | | | 16 | | pF |
| TRACK/HOLD | | | | | | |
| Acquisition Time | tACQ | | 600 | | | ns |
| Small-Signal Bandwidth | | | | 10 | | MHz |
| Full-Power Bandwidth | | | | 1.3 | | MHz |
| Drop Rate | | | | 2 | | mV/ms |
| Aperture Delay | | | | 10 | | ns |
| Aperture Jitter | | | | 30 | | ps |
| Aperture-Delay Matching | | | | 500 | | ps |
| REFERENCE OUTPUT (Note 7) | | | | | | |
| Output Voltage | VREFOUT | TA = +25°C | 2.462 | 2.5 | 2.532 | V |
| External Load Regulation | | 0 < IREF < 1mA | | 0.5 | | mV/mA |
| REFOUT Tempco | | (Note 8) | | 30 | | ppm/°C |
| External Capacitive Bypass at REFIN | | | 0.1 | | | µF |
| External Capacitive Bypass at REFOUT | | | 4.7 | | 22 | µF |
| REFERENCE INPUT | | | | | | |
| Input Voltage Range | | | 2.40 | 2.50 | 2.60 | V |
| Input Current | | | | | ±50 | µA |
| Input Resistance (Note 9) | | | | 10 | | kΩ |
| Input Capacitance | | | | 10 | | pF |
| EXTERNAL CLOCK | | | | | | |
| External Clock Frequency | | | | | 16 | MHz |
| INTERNAL CLOCK | | | | | | |
| Internal Clock Frequency | | | 5.6 | 10 | 14.8 | MHz |
| DIGITAL INPUTS (CONVST, RD, WR, CS, CLK, A0-A3) (Note 1) | | | | | | |
| Input High Voltage | VIH | | 2.4 | | | V |
| Input Low Voltage | VIL | | | | 0.8 | V |
| Input Current | IIN | CONVST, RD, WR, CS, CLK | | | ±1 | µA |
| | | A0-A3 | | | ±10 | |
| Input Capacitance | CIN | | | 15 | | pF |

2x4-Channel, Simultaneous-Sampling 12-Bit ADCs

ELECTRICAL CHARACTERISTICS (continued)

(AVDD = +5V ±5%, AVSS = -5V ±5%, DVDD = +5V ±5%, VREFIN = +2.5V (external reference), AGND = DGND = 0, 4.7µF capacitor from REFOUT to AGND, 0.1µF capacitor from REFIN to AGND, fCLK = 16MHz, external clock, 50% duty cycle. TA = TMIN to TMAX, unless otherwise noted. Typical values are at TA = +25°C.)

| PARAMETER | SYMBOL | CONDITIONS | MIN | TYP | MAX | UNITS |
|--------------------------------------|-------------------|---------------|-------|-----|-------|-------|
| DIGITAL OUTPUTS (D0–D11, INT) | | | | | | |
| Output High Voltage | VOH | IOUT = 1mA | 4 | | | V |
| Output Low Voltage | VOL | IOUT = -1.6mA | | | 0.4 | V |
| Three-State Leakage Current | | D0–D11 | | | ±10 | µA |
| Three-State Output Capacitance | | | | 10 | | pF |
| POWER REQUIREMENTS | | | | | | |
| Positive Supply Voltage | AVDD | | 4.75 | 5 | 5.25 | V |
| Negative Supply Voltage | AVSS | | -5.25 | -5 | -4.75 | V |
| Digital Supply Voltage | DVDD | | 4.75 | 5 | 5.25 | V |
| Positive Supply Current | I _{AVDD} | | | 17 | 25 | mA |
| Negative Supply Current | I _{AVSS} | | -20 | -15 | | mA |
| Digital Supply Current | | | | 3 | 6 | mA |
| Shutdown Positive Current | | | | 1 | | µA |
| Shutdown Negative Current | | | | -1 | | µA |
| Shutdown Digital Current | | | | 13 | | µA |
| Positive Supply Rejection | PSRR+ | (Note 10) | | | ±1 | LSB |
| Negative Supply Rejection | PSRR- | (Note 10) | | | ±1 | LSB |
| Power Dissipation | | (Note 11) | | 175 | | mW |

TIMING CHARACTERISTICS

(See Figure 4, AVDD = +5V, AVSS = -5V, DVDD = +5V, AGND = DGND = 0, TA = TMIN to TMAX, Typical values are at TA = +25°C, unless otherwise noted.)

| PARAMETER | SYMBOL | CONDITIONS | MIN | TYP | MAX | UNITS |
|---|---|----------------------|-----|-----|-----|-------|
| CONVST Pulse Width | t _{CW} | | 30 | | | ns |
| \overline{CS} to \overline{WR} Setup Time | t _{CWS} | Guaranteed by design | 0 | | | ns |
| \overline{CS} to \overline{WR} Hold Time | t _{CWH} | Guaranteed by design | 0 | | | ns |
| \overline{WR} Low Pulse Width | t _{\overline{WR}} | | 30 | | | ns |
| Address Setup Time | t _{AS} | | 30 | | | ns |
| Address Hold Time | t _{AH} | | 0 | | | ns |
| \overline{RD} to \overline{INT} Delay | t _{ID} | 25pF load | | | 55 | ns |
| Delay Time Between Reads | t _{RD} | | 45 | | | ns |
| \overline{CS} to \overline{RD} Setup Time | t _{CRS} | Guaranteed by design | 0 | | | ns |
| \overline{CS} to \overline{RD} Hold Time | t _{CRH} | Guaranteed by design | 0 | | | ns |
| \overline{RD} Low Pulse Width | t _{\overline{RD}} | | 30 | | | ns |
| Data-Access Time | t _{DA} | 25pF load (Note 12) | | | 40 | ns |
| Bus-Relinquish Time | t _{DH} | 25pF load (Note 13) | 5 | | 45 | ns |

2x4-Channel, Simultaneous-Sampling 12-Bit ADCs

MAX115/MAX116

TIMING CHARACTERISTICS (continued)

(See Figure 4, $AV_{DD} = +5V$, $AV_{SS} = -5V$, $DV_{DD} = +5V$, $AGND = DGND = 0$, $T_A = T_{MIN}$ to T_{MAX} , Typical values are at $T_A = +25^\circ C$, unless otherwise noted.)

| PARAMETER | SYMBOL | CONDITIONS | MIN | TYP | MAX | UNITS |
|-----------------|-------------------|-------------------|-----|-----|-----|-------|
| Conversion Time | t _{CONV} | Mode 1, channel 1 | | | 2 | μs |
| | | Mode 2, channel 2 | | | 4 | |
| | | Mode 3, channel 3 | | | 6 | |
| | | Mode 4, channel 4 | | | 8 | |
| Conversion Rate | | Mode 1, channel 1 | | | 390 | ksps |
| | | Mode 2, channel 2 | | | 218 | |
| | | Mode 3, channel 3 | | | 152 | |
| | | Mode 4, channel 4 | | | 116 | |
| Startup Time | | Exiting shutdown | | 20 | | ms |

Note 1: $AV_{DD} = +5V$, $AV_{SS} = -5V$, $DV_{DD} = +5V$, $V_{REFIN} = 2.500V$ (external), $V_{IN} = \pm 5V$ (MAX115) or $\pm 2.5V$ (MAX116).

Note 2: Integral nonlinearity is the analog value's deviation at any code from its theoretical value after the full-scale range and offset have been calibrated.

Note 3: CLK synchronized with \overline{CONVST} .

Note 4: $f_{IN} = 10.06kHz$, $V_{IN} = \pm 5V$ (MAX115) or $\pm 2.5V$ (MAX116).

Note 5: First five harmonics.

Note 6: All inputs except CH1A driven with $\pm 5V$ (MAX115) or $\pm 2.5V$ (MAX116) 10.06kHz signal, CH1A connected to AGND and digitized.

Note 7: $AV_{DD} = DV_{DD} = +5V$, $AV_{SS} = -5V$, $V_{IN} = 0V$ (all channels).

Note 8: Temperature drift is defined as the change in output voltage from $+25^\circ C$ to T_{MIN} or T_{MAX} . It is calculated as $TC = [\Delta REFOUT / REFOUT] / \Delta T$.

Note 9: See Figure 2.

Note 10: Defined as the change in positive full scale caused by a $\pm 5\%$ variation in the nominal supply voltage. Tested with one input at full scale and all others at AGND. $V_{REFIN} = +2.5V$ (internal).

Note 11: Tested with all inputs connected to AGND. $V_{REFIN} = +2.5V$ (internal).

Note 12: The data access time is defined as the time required for an output to cross $+0.8V$ or $+2.0V$. It is measured using the circuit of Figure 1. The measured number is then extrapolated back to determine the value with a 25pF load.

Note 13: The bus relinquish time is derived from the measured time taken for the data outputs to change $+0.5V$ when loaded with the circuit of Figure 1. The measured number is then extrapolated back to remove the effects of charging and discharging the 120pF capacitor. The time given is the part's true bus relinquish time, which is independent of the external bus loading capacitance.

2x4-Channel, Simultaneous-Sampling 12-Bit ADCs

Pin Description

| PIN | NAME | FUNCTION |
|--------|----------------------------|--|
| 1, 2 | CH2B, CH2A | Channel 2 Multiplexed Inputs (single-ended) |
| 3, 4 | CH1B, CH1A | Channel 1 Multiplexed Inputs (single-ended) |
| 5 | AV _{DD} | Analog Supply Voltage |
| 6 | REFIN | External reference input/internal reference output. Bypass with a 0.1 μ F capacitor to AGND. |
| 7 | REFOUT | Reference-Buffer output. Bypass with a 4.7 μ F capacitor to AGND. |
| 8, 36 | AGND | Analog ground. Both pins must be connected to ground. |
| 9-16 | D11-D4 | Data Bits. D11 = MSB. |
| 17 | DV _{DD} | Digital Supply Voltage |
| 18 | DGND | Digital Ground |
| 19, 20 | D3, D2 | Data Bits |
| 21, 22 | D1/A3, D0/A2 | Bidirectional Data Bits/Address Bits |
| 23, 24 | A1, A0 | Address Bits |
| 25 | CLK | Clock Input (duty cycle must be 30% to 70%). Connect CLK to DV _{DD} to activate internal clock. |
| 26 | $\overline{\text{CS}}$ | Chip-Select Input (active-low) |
| 27 | $\overline{\text{WR}}$ | Write Input (active-low) |
| 28 | $\overline{\text{RD}}$ | Read Input (active-low) |
| 29 | $\overline{\text{CONVST}}$ | Conversion-Start input. Rising edge initiates sampling and conversion sequence. |
| 30 | $\overline{\text{INT}}$ | Interrupt output. Falling edge indicates the end of a conversion sequence. |
| 31 | AV _{SS} | Analog Supply Voltage |
| 32, 33 | CH4A, CH4B | Channel 4 Multiplexed Inputs (single-ended) |
| 34, 35 | CH3A, CH3B | Channel 3 Multiplexed Inputs (single-ended) |

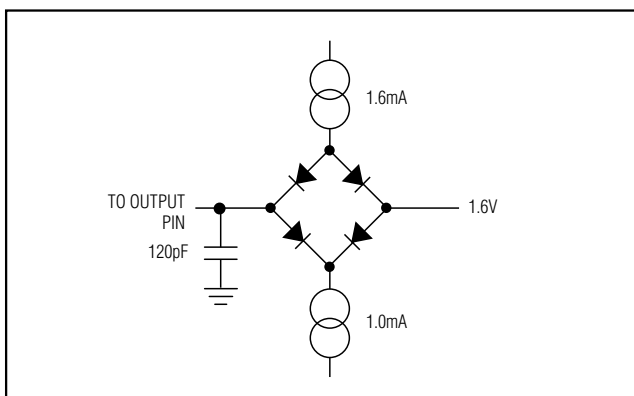

Figure 1. Load Circuit for Access Time and Bus Relinquish Time

Detailed Description

The MAX115/MAX116 use a successive-approximation conversion technique and four simultaneous-sampling track/hold (T/H) amplifiers to convert analog signals into 12-bit digital outputs. Each T/H has two multiplexed inputs, allowing a total of eight inputs. Each T/H output is converted and stored in memory to be accessed sequentially by the parallel interface with successive read cycles. The MAX115/MAX116 internal micro-sequencer can be programmed to digitize one, two, three, or four inputs sampled simultaneously from either of the two banks of four inputs (Figure 2). The MAX115/MAX116 can operate with either an external or internal clock. For internal operation, connect CLK to DV_{DD}.

2x4-Channel, Simultaneous-Sampling 12-Bit ADCs

MAX115/MAX116

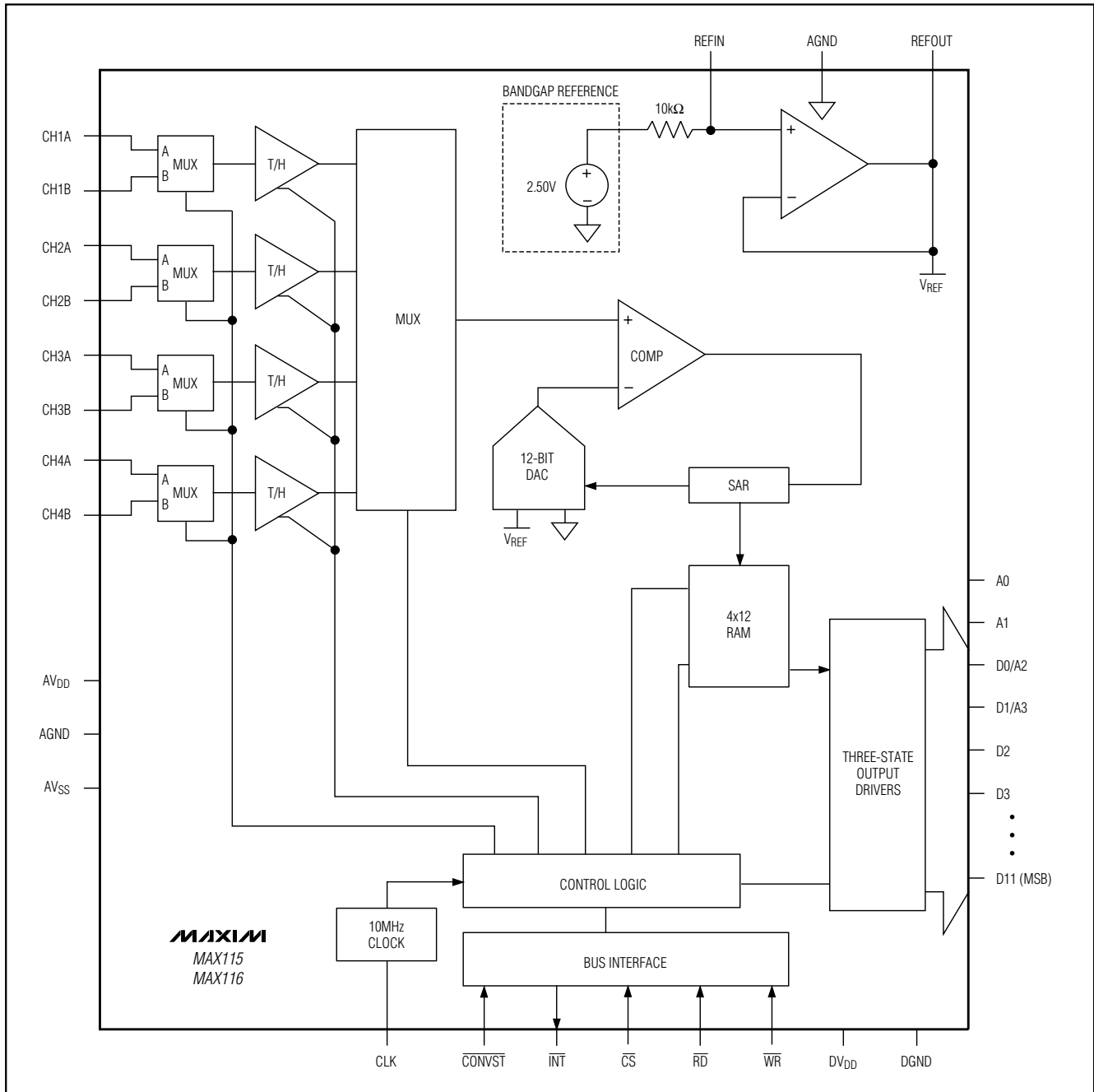

Figure 2. Functional Diagram

2x4-Channel, Simultaneous-Sampling 12-Bit ADCs

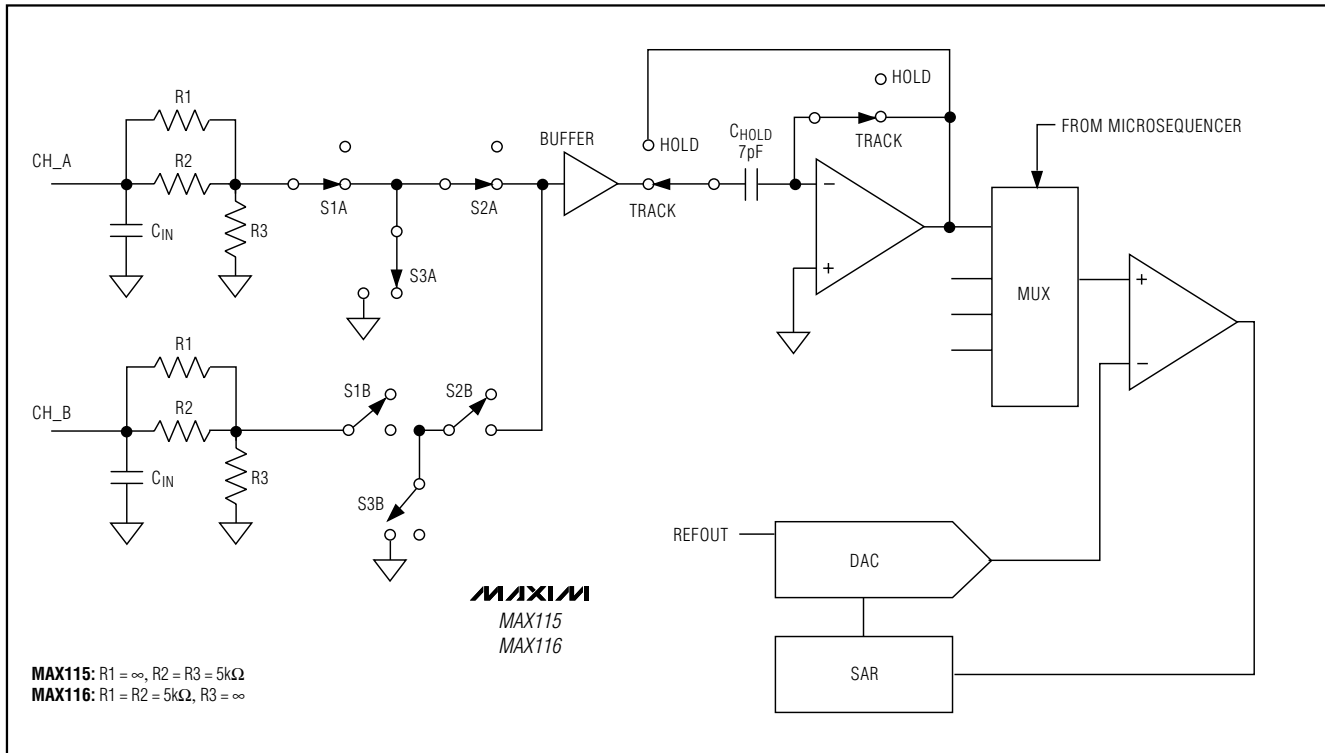

Figure 3. Equivalent Input Circuit

The conversion timing and control sequences are derived from either an internal clock or an external clock, the $\overline{\text{CONVST}}$ signal, and the programmed mode. The T/H amplifiers hold the input voltages at the $\overline{\text{CONVST}}$ rising edge. Additional $\overline{\text{CONVST}}$ pulses are ignored until the last conversion for the sample is complete. An on-board sequencer converts one to four channels per $\overline{\text{CONVST}}$ pulse. In the default mode, one T/H output (CH1A) is converted. An interrupt signal ($\overline{\text{INT}}$) is provided after the last conversion is complete. Convert two to four channels by reprogramming the MAX115/MAX116 through the bidirectional parallel interface. Once programmed, the MAX115/MAX116 continues to convert the specified number of channels per $\overline{\text{CONVST}}$ pulse until they are reprogrammed. The channels are converted sequentially, beginning with CH1. The $\overline{\text{INT}}$ signal always follows the end of the last conversion in a conversion sequence. The ADC converts each assigned channel in $2\mu\text{s}$ and stores the result in an internal 4×12 -bit memory.

At the end of the last conversion, $\overline{\text{INT}}$ goes low and the T/H amplifiers begin to track the inputs again. The data can be accessed by applying successive pulses to the $\overline{\text{RD}}$ pin. Successive reads access data words sequen-

tially. The memory is not random-access and data from CH1 is always read first. After performing four consecutive reads or initiating a new conversion, the address pointer selects CH1 again. Additional read pulses cycle through the data words. $\overline{\text{CS}}$ can be held low during successive reads.

Input Bandwidth

The T/H's input tracking circuitry has a 10MHz small-signal bandwidth, so it is possible to digitize high-speed transient events and measure periodic signals with bandwidths exceeding the ADC's sampling rate by using undersampling techniques. To avoid high-frequency signals being aliased into the frequency band of interest, anti-alias filtering is recommended.

Analog Input Range and Input Protection

The MAX115's input range is $\pm 5\text{V}$, and the MAX116's input range is $\pm 2.5\text{V}$. The input resistance for the MAX115 is $10k\Omega$ (typ), and the input resistance for the MAX116 is $1M\Omega$ (typ). An input protection structure allows input voltages to $\pm 17\text{V}$ without harming the IC. This protection is also active in shutdown mode.

2x4-Channel, Simultaneous-Sampling 12-Bit ADCs

MAX115/MAX116

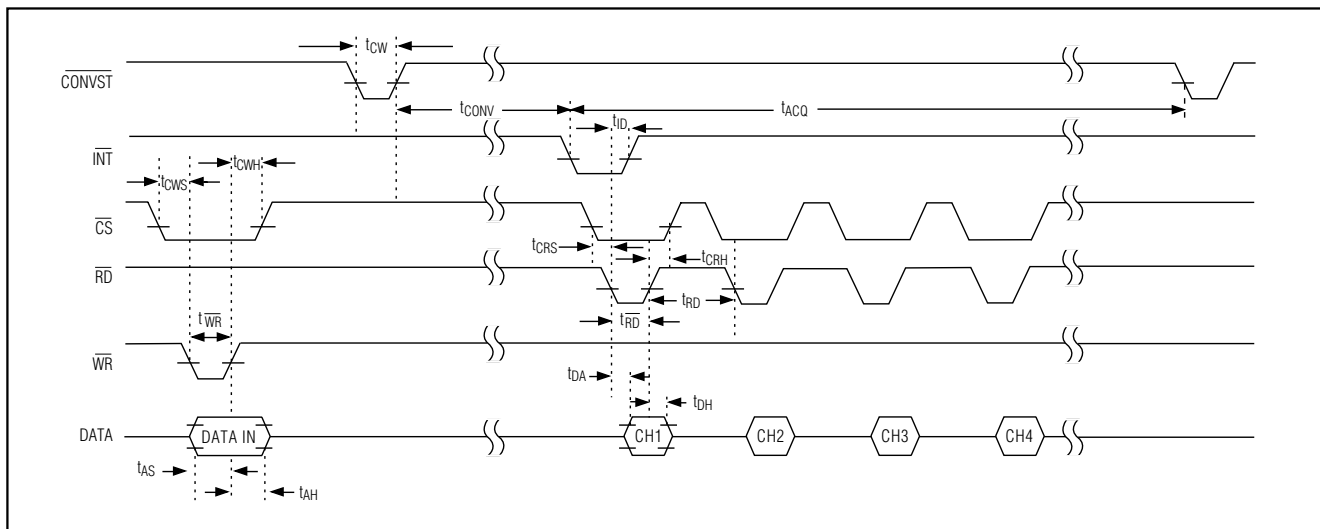

Figure 4. Timing Diagram

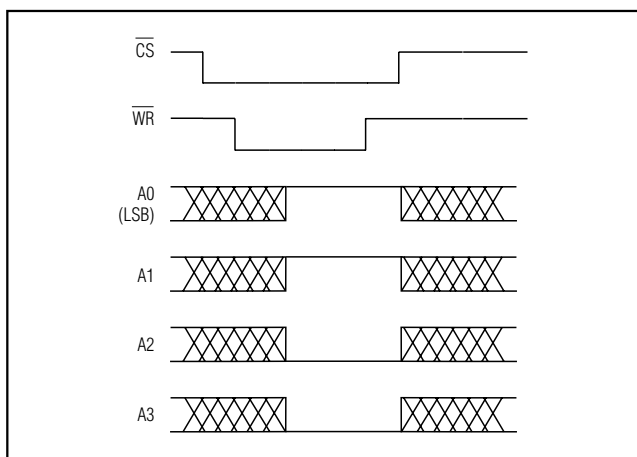

Figure 5. Programming a Four-Channel Conversion, Input Mux A

Track/Holds

The MAX115/MAX116 feature four simultaneous T/Hs. Each T/H has two multiplexed inputs. A T-switch input configuration provides excellent hold-mode isolation. Allow 600ns acquisition time for 12-bit accuracy.

The T/H aperture delay is typically 10ns. The 500ps aperture-delay mismatch between the T/Hs allows the relative phase information of up to four different inputs to be preserved. Figure 3 shows the equivalent input circuit, illustrating the ADC's sampling architecture. Only one of four T/H stages with its two multiplexed inputs (CH_A and CH_B) is shown. All switches are in track configuration for channel A. An internal buffer charges the hold capacitor to minimize the required

acquisition time between conversions. The analog input appears as a 10kΩ resistor in parallel with a 16pF capacitor for the MAX115 and as a 1MΩ resistor in parallel with a 16pF capacitor for the MAX116.

Between conversions, the buffer input is connected to channel 1 of the selected track/hold bank. When a channel is not selected, switches S1, S2, and S3 are placed in hold mode to improve channel-to-channel isolation.

Digital Interface

Input data (A0–A3) and output data (D0–D11) are multiplexed on a three-state bidirectional interface. This parallel I/O can easily be interfaced with a microprocessor (μP) or DSP. \overline{CS} , \overline{WR} , and \overline{RD} control the write and read operations. \overline{CS} is the standard chip-select signal, which enables the controller to address the MAX115/MAX116 as an I/O port. When \overline{CS} is high, it disables the \overline{WR} and \overline{RD} inputs and forces the interface into a high-Z state. Figure 4 details the interface timing.

Programming Modes

The MAX115/MAX116 have eight conversion modes plus power-down, which are programmed through a bidirectional parallel interface. At power-up, the devices default to the Input Mux A/Single-Channel Conversion mode. The user can select between two banks (mux inputs A or mux inputs B) of four simultaneous-sampled input channels, as illustrated in Figure 2. An internal microsequencer can be programmed to convert one to four channels of the selected bank per sample. For a single-channel conversion, CH1 is digitized, and then \overline{INT} goes low to indicate completion of the conversion.

2x4-Channel, Simultaneous-Sampling 12-Bit ADCs

Table 1. Modes of Operation

| A3 | A2 | A1 | A0 | CONVERSION TIME (μs) | MODE |
|----|----|----|----|-----------------------------------|---|
| 0 | 0 | 0 | 0 | 2 | Input Mux A/Single-Channel Conversion (default at power-up) |
| 0 | 0 | 0 | 1 | 4 | Input Mux A/Two-Channel Conversion |
| 0 | 0 | 1 | 0 | 6 | Input Mux A/Three-Channel Conversion |
| 0 | 0 | 1 | 1 | 8 | Input Mux A/Four-Channel Conversion |
| 0 | 1 | 0 | 0 | 2 | Input Mux B/Single-Channel Conversion |
| 0 | 1 | 0 | 1 | 4 | Input Mux B/Two-Channel Conversion |
| 0 | 1 | 1 | 0 | 6 | Input Mux B/Three-Channel Conversion |
| 0 | 1 | 1 | 1 | 8 | Input Mux B/Four-Channel Conversion |
| 1 | X | X | X | — | Power-Down |

X = Don't care

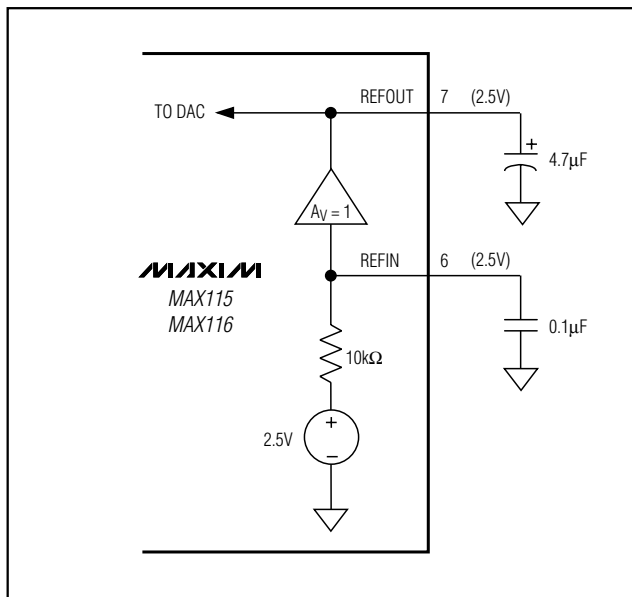

Figure 6. Internal Reference

For multichannel conversions, $\overline{\text{INT}}$ goes low after the last channel has been digitized.

To input data into the MAX115/MAX116, pull $\overline{\text{CS}}$ low, program the bidirectional pins A0–A3 (Table 1), and pulse $\overline{\text{WR}}$ low. Data is latched into the devices on the $\overline{\text{WR}}$ or $\overline{\text{CS}}$ rising edge. The ADC is now ready to convert. Once programmed, the ADC continues operating in the same mode until reprogrammed or until power is removed. Figure 5 shows an example of programming a four-channel conversion using Input Mux A.

Starting a Conversion

After programming the MAX115/MAX116 as outlined in the *Programming Modes* section, pulse $\overline{\text{CONVST}}$ low to initiate a conversion sequence. The analog inputs are sampled at the $\overline{\text{CONVST}}$ rising edge. Do not start a new conversion while the conversion is in progress. Monitor the $\overline{\text{INT}}$ output. A falling edge indicates the end of a conversion sequence.

Reading a Conversion

Digitized data from up to four channels is stored in memory to be read out through the parallel interface. After receiving an $\overline{\text{INT}}$ signal, the user can access up to four conversion results by performing up to four read operations.

With $\overline{\text{CS}}$ low, the conversion results from CH1_- are accessed, and $\overline{\text{INT}}$ is reset high on the first $\overline{\text{RD}}$ falling edge. On the $\overline{\text{RD}}$ rising edge, the internal address pointer is advanced. If a single conversion is programmed, only one $\overline{\text{RD}}$ pulse is required. For multichannel conversions, up to four $\overline{\text{RD}}$ falling edges sequentially access the data for channels 1 through 4. For any number of channels converted, the address pointer is reset to CH1_- after four $\overline{\text{RD}}$ pulses. The address pointer also resets after receiving a $\overline{\text{CONVST}}$ pulse. Do not perform a read operation during conversion; it will corrupt the conversion's accuracy.

Applications Information

Clock

The MAX115/MAX116 have an internal 10MHz (typ) clock, which is activated by connecting CLK to DV_{DD} (internal clock startup time is 165 μs typ). The CLK input also accepts an external clock with duty cycle between 30% and 70%.

2x4-Channel, Simultaneous-Sampling 12-Bit ADCs

MAX115/MAX116

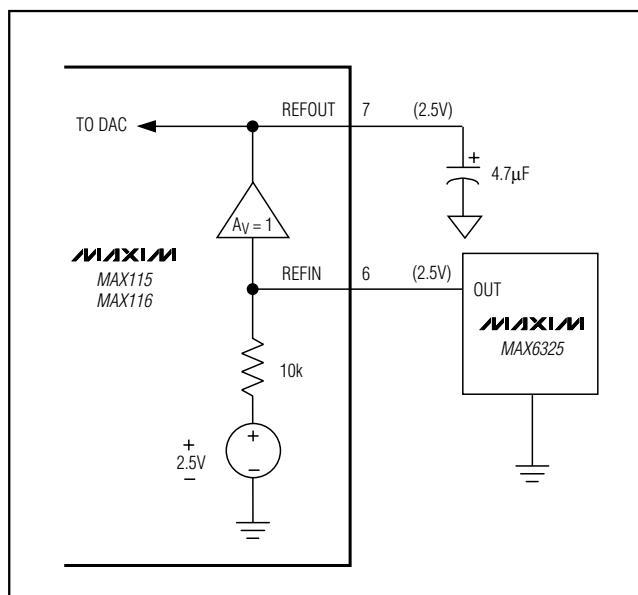

Figure 7. External Reference

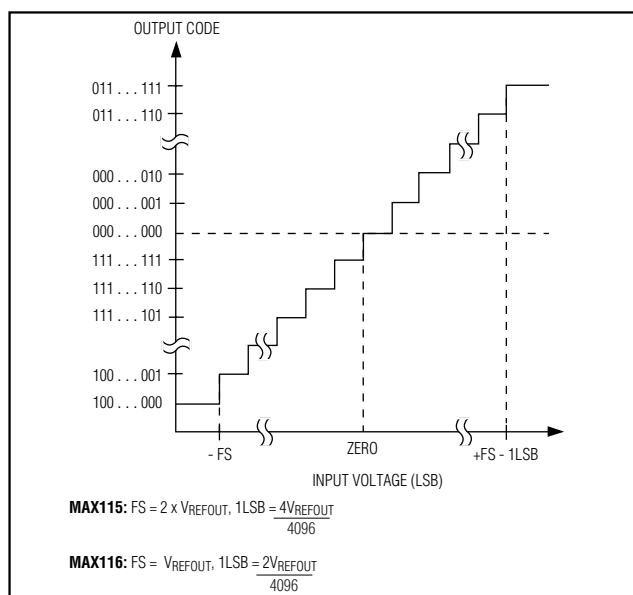

Figure 8. Bipolar Transfer Function

Internal and External Reference

The MAX115/MAX116 can be used with an internal or external reference voltage. An external +2.5 reference can be connected directly at REFIN. An internal buffer with a gain of +1 provides +2.5V at REFOUT.

Internal Reference

The full-scale range with the internal reference is $\pm 5V$ for the MAX115 and $\pm 2.5V$ for the MAX116. Bypass REFIN with a $0.1\mu F$ capacitor to AGND, and bypass the REFOUT pin with a $4.7\mu F$ (min) capacitor to AGND (Figure 6). The maximum value to compensate the reference buffer is $22\mu F$. Larger values are acceptable if low-ESR capacitors are used.

External Reference

For operation over a wide temperature range, an external +2.5V reference with tighter specifications improves accuracy. The MAX6325 is an excellent choice to match the MAX115/MAX116 accuracy over the commercial and extended temperature ranges with a $1\text{ppm}/^\circ\text{C}$ (max) temperature drift. Connect an external reference at REFIN as shown in Figure 7. The minimum impedance is $7k\Omega$ for DC currents in both normal operation and shutdown. Bypass REFOUT with a $4.7\mu F$ low-ESR capacitor.

Power-On Reset

When power is first applied, the internal power-on reset (POR) circuitry activates the MAX115/MAX116 with INT = high, ready to convert. The default conversion mode

is Input Mux A/Single Channel Conversion. See the *Programming Modes* section if other configurations are desired.

After the power supplies have been stabilized, the reset time is $5\mu s$. No conversions should be performed during this phase. At power-up, data-in memory is undefined.

Software Power-Down

Software power-down is activated by setting bit A3 of the control word high (Table 1). It is asserted after the \overline{WR} or \overline{CS} rising edge, at which point the ADC immediately powers down to a low quiescent-current state. I_{AVDD} and I_{AVSS} drop to less than $1\mu A$ (typ), and I_{DVDD} drops to $13\mu A$ (typ). The ADC circuitry and reference buffer are turned off, but the digital interface and the reference remain active for fast power-up recovery. Wake up the MAX115/MAX116 by writing a control word (A0–A3, Table 1). The bidirectional interface interprets a logic zero at A3 as the start signal, and powers up in the mode selected by A0, A1, and A2. The reference buffer's settling time and the bypass capacitor's value dominate the power-up delay. With the recommended $4.7\mu F$ at REFOUT, the power-up delay is typically 20ms.

Transfer Function

The MAX115/MAX116 have bipolar input ranges. Figure 8 shows the bipolar/output transfer function. Code transitions occur at successive-integer least significant bit

2x4-Channel, Simultaneous-Sampling 12-Bit ADCs

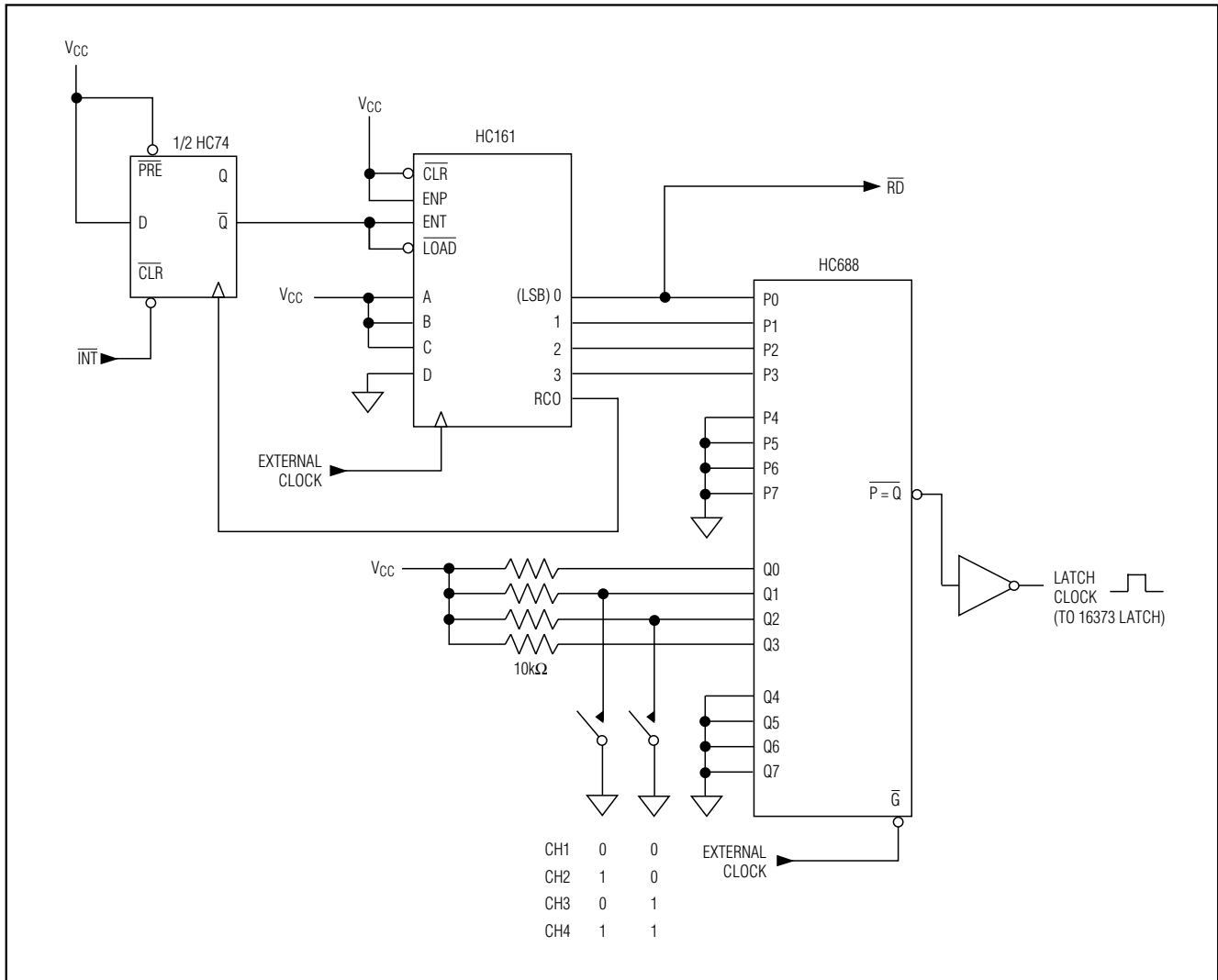

Figure 9. Output Demultiplexer Circuit

(LSB) values. Output coding is two-complement binary with 1LSB = 2.44mV for the MAX115 and 1LSB = 1.22mV for the MAX116.

Output Demultiplexer

An output demultiplexer circuit is useful for isolating data from one channel in a four-channel conversion sequence. Figure 9's circuit uses the external 16MHz clock and the INT signal to generate four RD pulses and a latch clock to save data from the desired channel. CS must be low during the four RD pulses. The channel is selected with the binary coding of two switches. A 16-bit 16373 latch simplifies layout.

Motor-Control Applications

Vector motor control requires monitoring of the individual phase currents. In their most basic application, the MAX115/MAX116 simultaneously sample two currents (CH1A and CH2A, Figure 10) and preserve the necessary relative phase information. Only two of the three phase currents have to be digitized because the third component can be mathematically derived with a coordinate transformation.

The circuit of Figure 10 shows a typical vector motor-control application using all available inputs of the MAX115/MAX116. CH1A and CH2A are connected to two isolated Hall-effect current sensors and are a

2x4-Channel, Simultaneous-Sampling 12-Bit ADCs

MAX115/MAX116

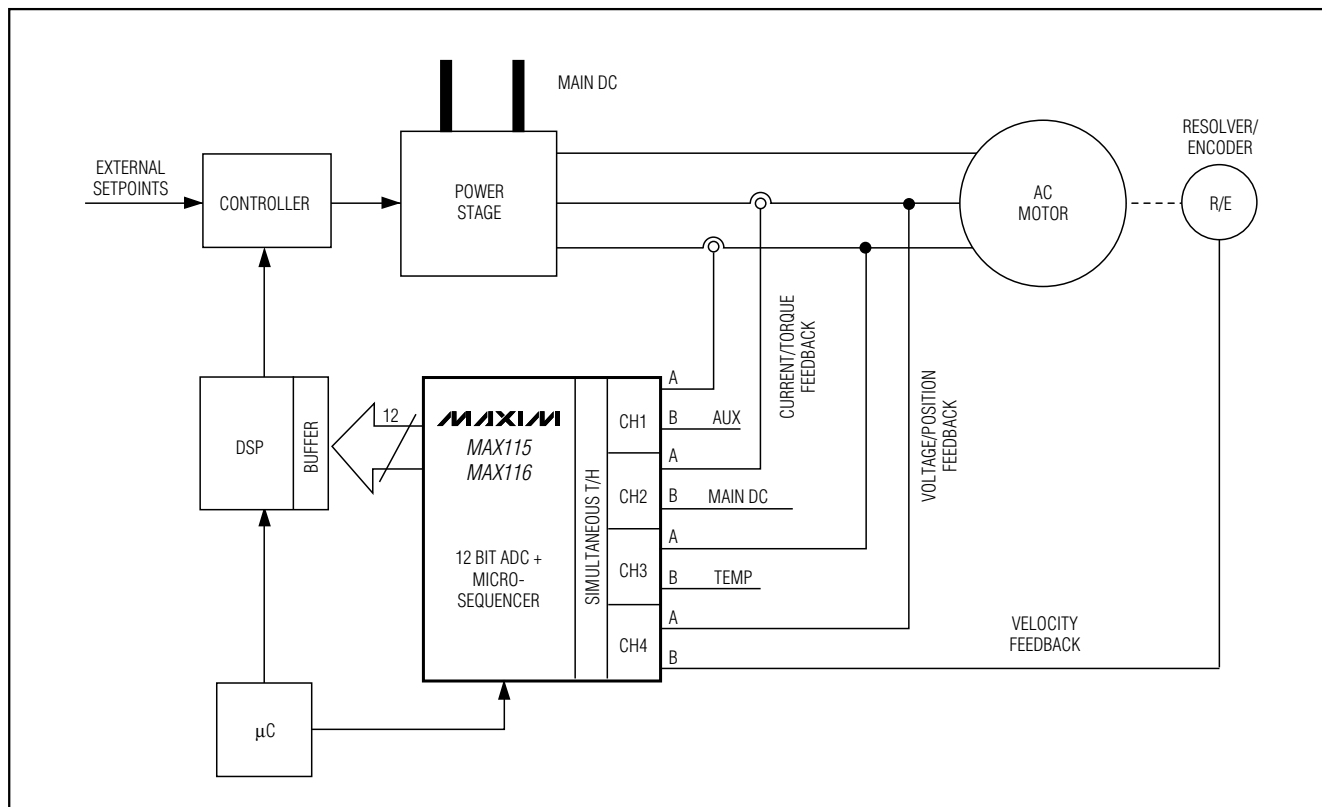

Figure 10. Vector Motor Control

part of the current (torque) feedback loop. The MAX115/MAX116 digitize the currents and deliver raw data to the following DSP and controller stages, where the vector processing takes place. Sensorless vector control uses a computer model for the motor and an algorithm to split each output current into its magnetizing (stator current) and torque-producing (rotor current) components.

If a two-to-three phase conversion is not practical, three currents can be sampled simultaneously with the addition of a third sensor (not shown). Optional voltage (position) feedback can be derived by measuring two phase voltages (CH3A, CH4A). Typically, an isolated differential amplifier is used between the motor and the MAX115/MAX116. Again, the third phase voltage can be derived from the magnitude (phase voltage) and its relative phase.

For optimum speed control and good load regulation close to zero speed, additional velocity and position feedback are derived from an encoder or resolver and brought to the MAX115/MAX116 at CH4B. The addi-

tional channels can be used to evaluate slower analog inputs, such as the main DC bus voltage (CH2B), temperature sensors (CH3B), or other analog inputs (AUX, CH1B).

Power-Supply Bypassing and Ground Management

For optimum system performance, use printed circuit boards with separate analog and digital ground planes. Wire-wrapped boards are not recommended. Connect the two ground planes together at the low-impedance power-supply source. For the best ground connection, connect the DGND and AGND pins together and connect that point to the system analog ground plane to avoid interference from other digital noise sources. If DGND is connected to the system digital ground, digital noise may get through to the ADC's analog portion.

The AGND pins must be connected directly to a low-impedance ground plane. Extra impedance between the pins and the ground plane increases crosstalk and degrades INL.

2x4-Channel, Simultaneous-Sampling 12-Bit ADCs

Bypass AV_{DD} and AV_{SS} with 0.1μF ceramic capacitors to AGND. Mount them with short leads close to the device. Ferrite beads may also be used to further isolate the analog and digital power supplies. Bypass DV_{DD} with a 0.1μF ceramic capacitor to DGND.

Chip Information

TRANSISTOR COUNT: 4116
SUBSTRATE CONNECTED TO AV_{SS}
PROCESS: BiCMOS

Package Information

| | INCHES | | MILLIMETERS | |
|----|--------|-------|-------------|-------|
| | MIN | MAX | MIN | MAX |
| A | 0.094 | 0.104 | 2.39 | 2.65 |
| A1 | 0.004 | 0.011 | 0.10 | 0.28 |
| B | 0.011 | 0.017 | 0.30 | 0.44 |
| C | 0.009 | 0.012 | 0.23 | 0.32 |
| e | 0.0315 | | 0.80 | |
| E | 0.292 | 0.298 | 7.42 | 7.57 |
| H | 0.398 | 0.416 | 10.10 | 10.57 |
| L | 0.020 | 0.035 | 0.51 | 0.89 |

| | INCHES | | MILLIMETERS | | N |
|---|--------|-------|-------------|-------|----|
| | MIN | MAX | MIN | MAX | |
| D | 0.604 | 0.610 | 15.34 | 15.49 | 36 |
| D | 0.702 | 0.708 | 17.83 | 17.98 | 44 |

NOTES:
 1. D&E DO NOT INCLUDE MOLD FLASH
 2. MOLD FLASH OR PROTRUSIONS NOT TO EXCEED .15mm (.006")
 3. LEADS TO BE COPLANAR WITHIN .102mm (.004")
 4. CONTROLLING DIMENSION: MILLIMETER
 5. N = NUMBER OF PINS

PROPRIETARY INFORMATION

TITLE:
PACKAGE OUTLINE, SSOP, 36/44L, .300X8mm

| | | |
|----------|----------------------|-------|
| APPROVAL | DOCUMENT CONTROL NO. | REV |
| | 21-0040 | B 1/1 |

SSOP-44L

Maxim cannot assume responsibility for use of any circuitry other than circuitry entirely embodied in a Maxim product. No circuit patent licenses are implied. Maxim reserves the right to change the circuitry and specifications without notice at any time.

14 Maxim Integrated Products, 120 San Gabriel Drive, Sunnyvale, CA 94086 408-737-7600

Компания «Life Electronics» занимается поставками электронных компонентов импортного и отечественного производства от производителей и со складов крупных дистрибьюторов Европы, Америки и Азии.

С конца 2013 года компания активно расширяет линейку поставок компонентов по направлению коаксиальный кабель, кварцевые генераторы и конденсаторы (керамические, пленочные, электролитические), за счёт заключения дистрибьюторских договоров

Мы предлагаем:

- Конкурентоспособные цены и скидки постоянным клиентам.
- Специальные условия для постоянных клиентов.
- Подбор аналогов.
- Поставку компонентов в любых объемах, удовлетворяющих вашим потребностям.
- Приемлемые сроки поставки, возможна ускоренная поставка.
- Доставку товара в любую точку России и стран СНГ.
- Комплексную поставку.
- Работу по проектам и поставку образцов.
- Формирование склада под заказчика.
- Сертификаты соответствия на поставляемую продукцию (по желанию клиента).
- Тестирование поставляемой продукции.
- Поставку компонентов, требующих военную и космическую приемку.
- Входной контроль качества.
- Наличие сертификата ISO.

В составе нашей компании организован Конструкторский отдел, призванный помогать разработчикам, и инженерам.

Конструкторский отдел помогает осуществить:

- Регистрацию проекта у производителя компонентов.
- Техническую поддержку проекта.
- Защиту от снятия компонента с производства.
- Оценку стоимости проекта по компонентам.
- Изготовление тестовой платы монтаж и пусконаладочные работы.



Тел: +7 (812) 336 43 04 (многоканальный)

Email: org@lifeelectronics.ru