

## DATA-CON-X™: SEALED USB TYPE A & B CONNECTORS

NEW PRODUCT BULLETIN C711

# CONXALL®

A SWITCHCRAFT COMPANY



CONXALL • 601 E Wildwood • Villa Park, IL 60181 • 630-834-7504  
Please visit [conxall.com](http://conxall.com) for the most up-to-date product specifications. Made in the USA.

# DATA-CON-X™: SEALED USB TYPE A & B CONNECTORS

NEW PRODUCT BULLETIN C711



## FEATURES & BENEFITS

- Sealed to IP67 & IP68 NEMA 250 (6P) (when mated)
- Feed-thru termination on the panel for easy field installation
- Field installable design is easy to assemble
- Quick connect bayonet or threaded style interface
- RoHS compliant assembly
- UV F1 rated housing

## APPLICATIONS

- Any sealed data transmission
- Military or industrial GPS location devices
- Instrumentation
- Medical data carts
- Data acquisition units
- General industrial electronic applications



# DATA-CON-X™: SEALED USB TYPE A & B CONNECTORS

NEW PRODUCT BULLETIN C711

## SPECIFICATIONS

### MECHANICAL SPECIFICATIONS

Life:	Minimum 350 insertion/withdrawal cycles
Hex Nut Torque:	10-12 in-lb max
Coupling Locking Style:	Quick Connect (Bayonet) or Threaded
Backshell Style:	Threaded Nut-Squeezed Grommet

### ELECTRICAL SPECIFICATIONS

Current Rating:	1.5 A
Voltage Rating:	Per USB 2.0 standard
Contact Resistance:	30 mΩ max
Insulation Resistance:	1000 MΩ min
Dielectric Withstanding Voltage:	500 V AC/one minute

### ENVIRONMENTAL SPECIFICATIONS

Operating Temperature Rating:	0 °C to +50 °C (+32°F to +122°F)
Storage Temperature:	-20 °C to +60 °C (-4°F to +140°F)
Moisture Resistance:	Mil-Std 202G Method 106G
Insulation Resistance:	Mil-Std 202G Method 302
Vibration:	Mil-Std 202G Method 201A
Thermal Shock:	Mil-Std 202G Method 107G
Weathertight:	IP67 & IP68, NEMA 250 (6P) (when mated)
Salt Spray:	Mil-Std 202G Method 101E
Product Ratings:	Tested per USB 2.0

### MATERIAL SPECIFICATIONS

Plug Nut, Coupling Ring:	Thermoplastic
Plug Housing, Insert:	Thermoplastic
Sealing Ring, O-Ring:	Elastomer
Panel Housing, Hex Nut:	Thermoplastic
Retaining Nut:	Copper Alloy, Nickel Plated
Gasket:	Elastomer

#### USB A or B Plug:

Shell:	Steel, Nickel Plated
Contacts:	Copper Alloy, Gold Plated
Insulator:	Thermoplastic UL94V-0, White

#### USB A Receptacle:

Shell:	Steel, Nickel Plated
Contacts:	Copper Alloy, Gold Plated
Insulator:	Thermoplastic UL94V-0, White

#### USB B Receptacle:

Shell:	Copper Alloy, Nickel Plated
Contacts:	Copper Alloy, Gold Plated
Insulator:	Thermoplastic UL94V-0, White

### MOLDED CABLE ASSEMBLIES

Consult factory for molded options

### OTHER

Flame Rating:	UL 94V-0
Recommended Panel Thickness:	1/32" - 3/16" [0.8mm to 4.8mm] - Quick Connect Coupling 1/32" - 5/32" [0.8mm to 3.9mm] - Threaded Coupling

### Recommended Cable Type

Conductor Type:	Solid or Stranded Conductors
Outer Cable O.D. Range:	Product 150 Series: 0.134"-0.170" [3.40mm-4.33mm] Product 180 Series: 0.171"-0.208" [4.34mm-5.28mm]



CONXALL • 601 E Wildwood • Villa Park, IL 60181 • 630-834-7504

Please visit [conxall.com](http://conxall.com) for the most up-to-date product specifications. Made in the USA.

# DATA-CON-X™: SEALED USB TYPE A & B CONNECTORS

## NEW PRODUCT BULLETIN C711

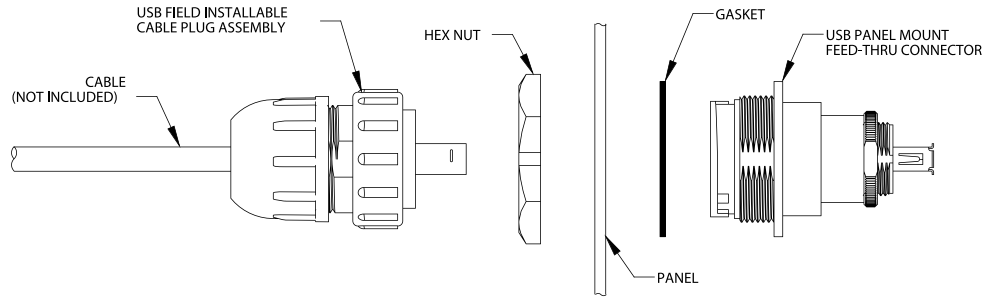

**USB A FIELD INSTALLABLE CABLE PLUG**  
(SHOWN WITH QUICK CONNECT COUPLING)

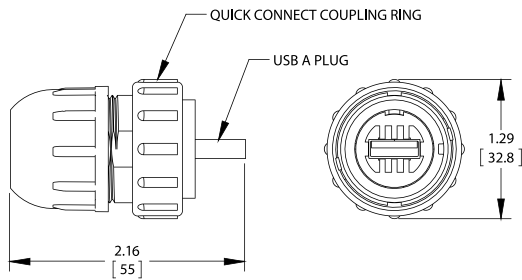

**USB B FIELD INSTALLABLE CABLE PLUG**  
(SHOWN WITH THREADED COUPLING)

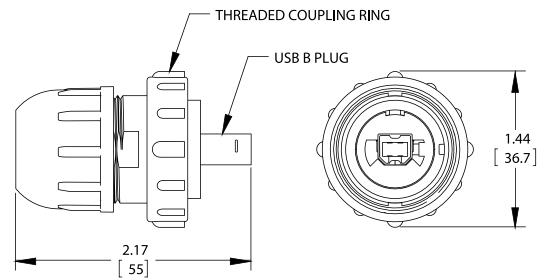

**USB PANEL MOUNT FEED-THRU CONNECTOR**  
(SHOWN WITH USB A TO B FEED-THRU CONNECTOR)  
(SHOWN WITH THREADED HOUSING)

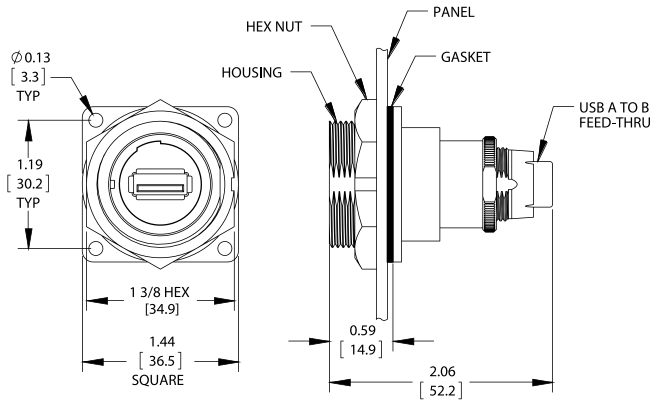

**USB PANEL MOUNT FEED-THRU CONNECTOR**  
(SHOWN WITH USB B TO A FEED-THRU CONNECTOR)  
(SHOWN WITH QUICK CONNECT HOUSING)

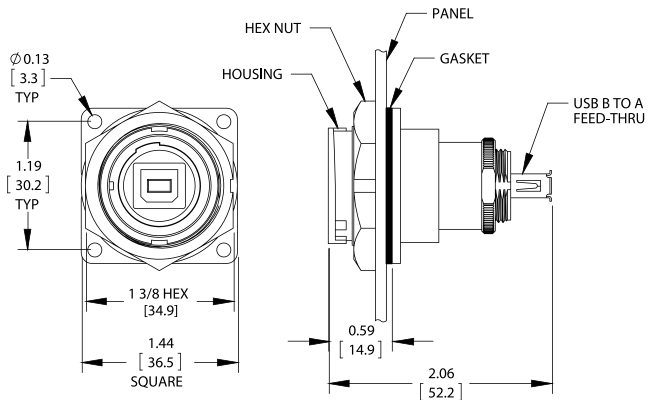

**USB FIELD INSTALLABLE CABLE PLUG PART NUMBER CHART**

USB FIELD INSTALLABLE CABLE PLUG ASSEMBLY	PLUG TYPE	COUPLING TYPE	SERIES
<b>DCC</b>	<b>USBA</b> = USB "A" 2.0 <b>USBB</b> = USB "B" 2.0	<b>B</b> = QUICK CONNECT <b>T</b> = THREADED	<b>150</b> = Ø0.134-0.170 [3.40-4.33MM] <b>180</b> = Ø0.171-0.208 [4.34-5.28MM]

**USB PANEL MOUNT FEED-THRU CONNECTORS PART NUMBER CHART**

USB FIELD INSTALLABLE PANEL HOUSING ASSEMBLY	RECEPTACLE TYPE (SEALED END)	COUPLING TYPE	RECEPTACLE TYPE (NON-SEALED END)
<b>DCP</b>	<b>USBA</b> = USB "A" 2.0 <b>USBB</b> = USB "B" 2.0	<b>B</b> = QUICK CONNECT <b>T</b> = THREADED	<b>USBA</b> = USB "A" 2.0 (NOT AVAILABLE WITH USBA ON SEALED END) <b>USBB</b> = USB "B" 2.0 (NOT AVAILABLE WITH USBB ON SEALED END)



# DATA-CON-X™: SEALED USB TYPE A & B CONNECTORS

NEW PRODUCT BULLETIN C711

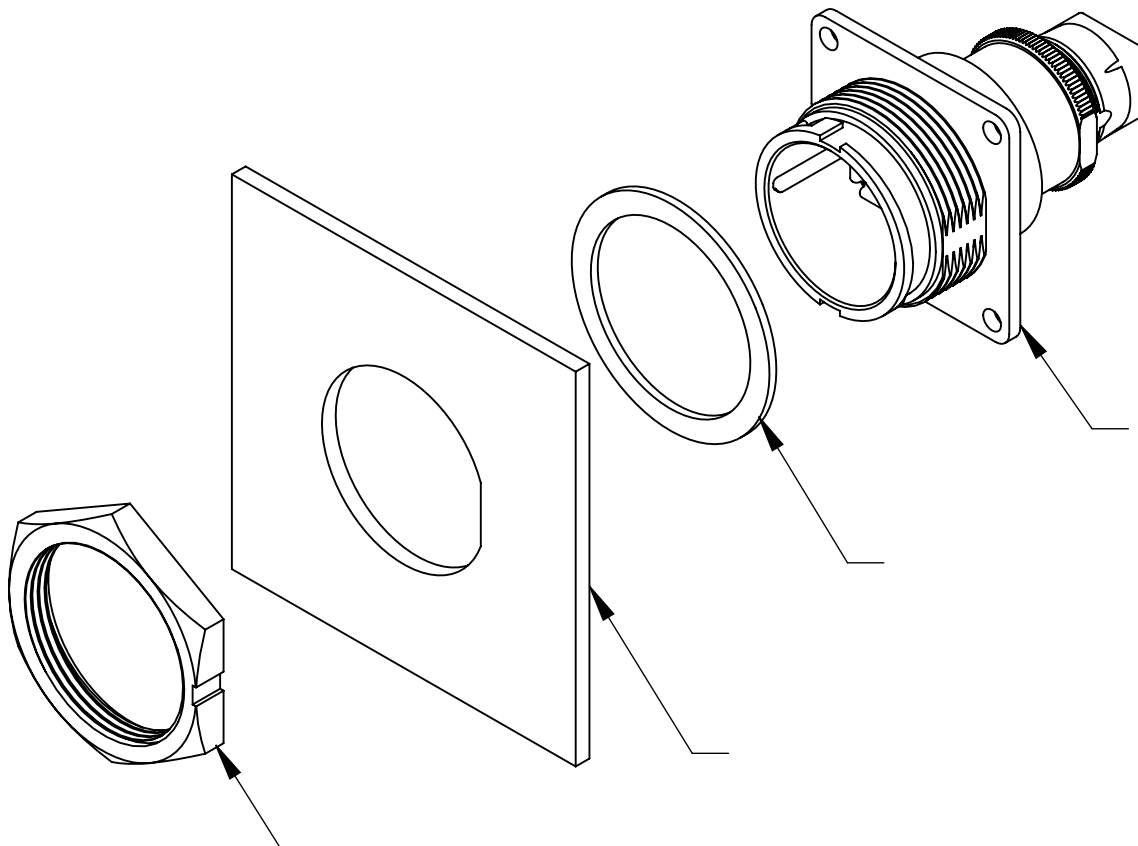

## NOTES:

1. DCP-USBAB-USBB SHOWN IN EXPLODED VIEW. (USB A TO B WITH QUICK CONNECT COUPLING.)
2. MATED ASSEMBLY MEETS IP-67 & IP-68, NEMA 250 (6P).
3. THESE ASSEMBLIES ARE RoHS COMPLIANT.

## MATERIALS:

GASKET: ELASTOMER  
HEX NUT: THERMOPLASTIC  
USB PANEL HOUSING: THERMOPLASTIC  
RETAINING NUT: COPPER ALLOY, NICKEL PLATED  
USB A RECEPTACLE:  
SHELL: STEEL, NICKEL PLATED  
CONTACTS: COPPER ALLOY, GOLD PLATED  
INSULATOR: THERMOPLASTIC  
USB B RECEPTACLE:  
SHELL: COPPER ALLOY, NICKEL PLATED  
CONTACTS: COPPER ALLOY, GOLD PLATED  
INSULATOR: THERMOPLASTIC

## OTHER:

RECOMMENDED PANEL THICKNESS:  
QUICK CONNECT COUPLING: 1/32" TO 3/16" (0.8mm to 4.8mm)  
THREADED COUPLING: 1/32" TO 5/32" (0.8mm to 3.9mm)



CONXALL • 601 E Wildwood • Villa Park, IL 60181 • 630-834-7504  
Please visit [conxall.com](http://conxall.com) for the most up-to-date product specifications. Made in the USA.

# DATA-CON-X™: SEALED USB TYPE A & B CONNECTORS

## NEW PRODUCT BULLETIN C711

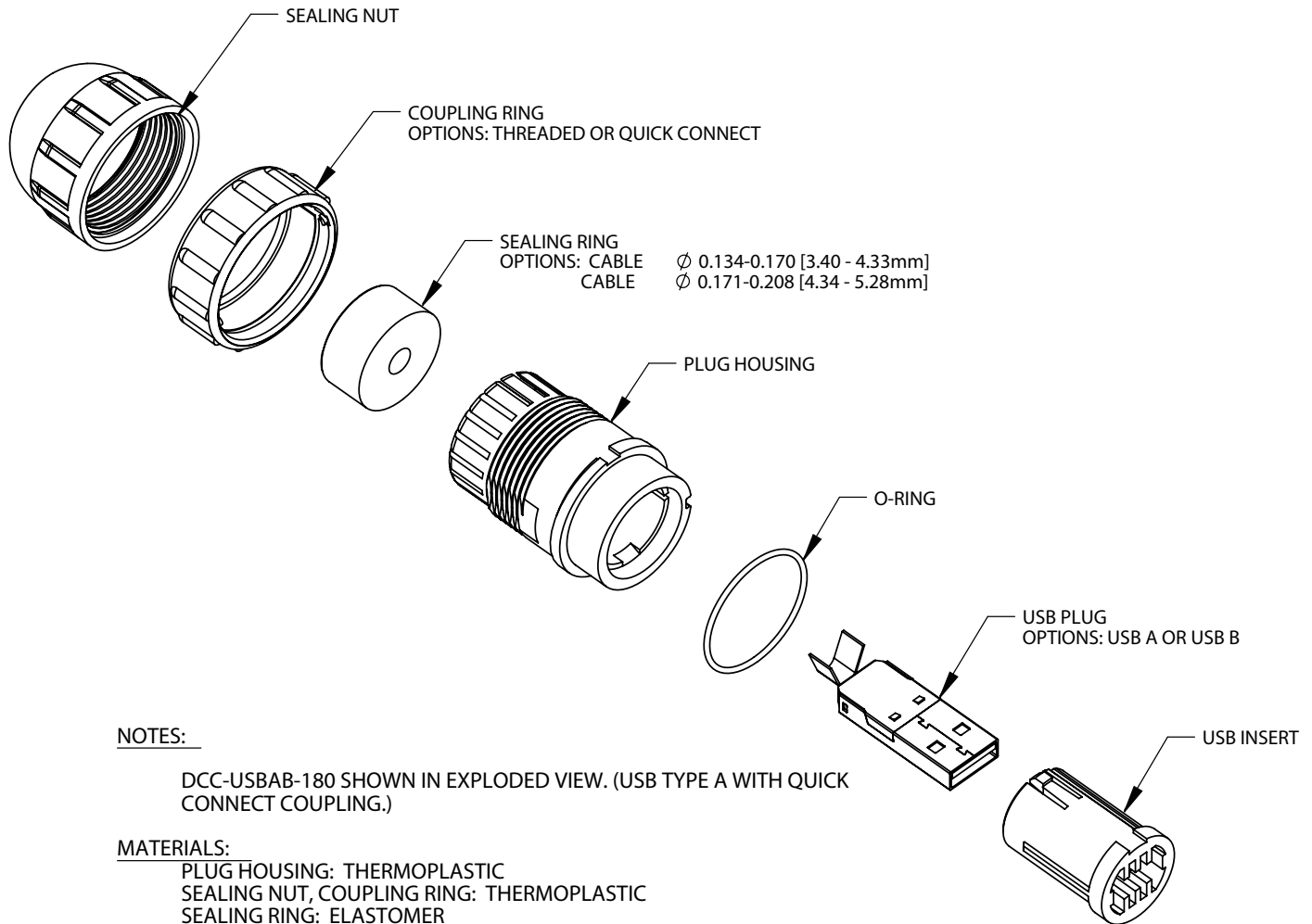

### NOTES:

DCC-USBAB-180 SHOWN IN EXPLODED VIEW. (USB TYPE A WITH QUICK CONNECT COUPLING.)

### MATERIALS:

PLUG HOUSING: THERMOPLASTIC  
SEALING NUT, COUPLING RING: THERMOPLASTIC  
SEALING RING: ELASTOMER  
O-RING: ELASTOMER  
INSERT: THERMOPLASTIC  
USB PLUG:  
INSULATOR: THERMOPLASTIC  
CONTACTS: COPPER ALLOY, GOLD PLATED  
SHIELD: COPPER ALLOY, TIN PLATED

### ELECTRICAL:

VOLTAGE RATING: PER USB 2.0 STANDARD  
CONTACT RESISTANCE: 30 MILLIOHMS MAXIMUM  
CONTACT CURRENT RATING: 1.5 A MINIMUM  
INSULATION RESISTANCE: 1000 MEGAOHMS MINIMUM  
WITHSTANDING VOLTAGE: 500VAC FOR 1 MINUTE

### PRODUCT RATING:

IP67 & IP68, NEMA 250 (6P) WHEN MATED  
USB A PLUG: USB 2.0  
USB B PLUG: USB 2.0

### OTHER:

OPERATING TEMPERATURE: 0 °C TO +50 °C  
RECOMMENDED CABLE TYPE: SOLID OR STRANDED CONDUCTORS  
OUTER CABLE O.D. RANGE:  
PRODUCT 150 SERIES: 0.134-0.170 [3.40mm-4.33mm]  
PRODUCT 180 SERIES: 0.171-0.208 [4.34mm-5.28mm]



Компания «Life Electronics» занимается поставками электронных компонентов импортного и отечественного производства от производителей и со складов крупных дистрибьюторов Европы, Америки и Азии.

С конца 2013 года компания активно расширяет линейку поставок компонентов по направлению коаксиальный кабель, кварцевые генераторы и конденсаторы (керамические, пленочные, электролитические), за счёт заключения дистрибьюторских договоров

Мы предлагаем:

- Конкурентоспособные цены и скидки постоянным клиентам.
- Специальные условия для постоянных клиентов.
- Подбор аналогов.
- Поставку компонентов в любых объемах, удовлетворяющих вашим потребностям.
- Приемлемые сроки поставки, возможна ускоренная поставка.
- Доставку товара в любую точку России и стран СНГ.
- Комплексную поставку.
- Работу по проектам и поставку образцов.
- Формирование склада под заказчика.
- Сертификаты соответствия на поставляемую продукцию (по желанию клиента).
- Тестирование поставляемой продукции.
- Поставку компонентов, требующих военную и космическую приемку.
- Входной контроль качества.
- Наличие сертификата ISO.

В составе нашей компании организован Конструкторский отдел, призванный помогать разработчикам, и инженерам.

Конструкторский отдел помогает осуществить:

- Регистрацию проекта у производителя компонентов.
- Техническую поддержку проекта.
- Защиту от снятия компонента с производства.
- Оценку стоимости проекта по компонентам.
- Изготовление тестовой платы монтаж и пусконаладочные работы.



Тел: +7 (812) 336 43 04 (многоканальный)

Email: [org@lifeelectronics.ru](mailto:org@lifeelectronics.ru)