

General Description

The 9DMU0431 is a member of IDT's SOC-Friendly 1.5V Ultra-Low-Power (ULP) PCIe Gen1-2-3 family. Each of the 4 outputs has its own dedicated OE# pin for optimal system control and power management. The part provides asynchronous and glitch-free switching modes.

Recommended Application

2:4 PCIe Gen1-2-3 clock multiplexer

Output Features

- 4 – Low-Power (LP) HCSL DIF pair

Key Specifications

- DIF *additive* cycle-to-cycle jitter <5ps
- DIF phase jitter is PCIe Gen1-2-3 compliant
- Additive phase jitter @ 125MHz: 535fs rms typical (12kHz to 20MHz)
- DIF output-to-output skew <50ps

Features/Benefits

- LP-HCSL outputs; save 8 resistors compared to standard HCSL outputs
- 1.5V operation; 31mW typical power consumption
- Selectable asynchronous or glitch-free switching; allows the mux to be selected at power up even if both inputs are not running, then transition to glitch-free switching mode
- Spread Spectrum Compatible; supports EMI reduction
- OE# pins; support DIF power management
- HCSL differential inputs; can be driven by common clock sources
- 1MHz to 167MHz operating frequency
- Space saving 24-pin 4x4mm VFQFPN; minimal board space

Block Diagram

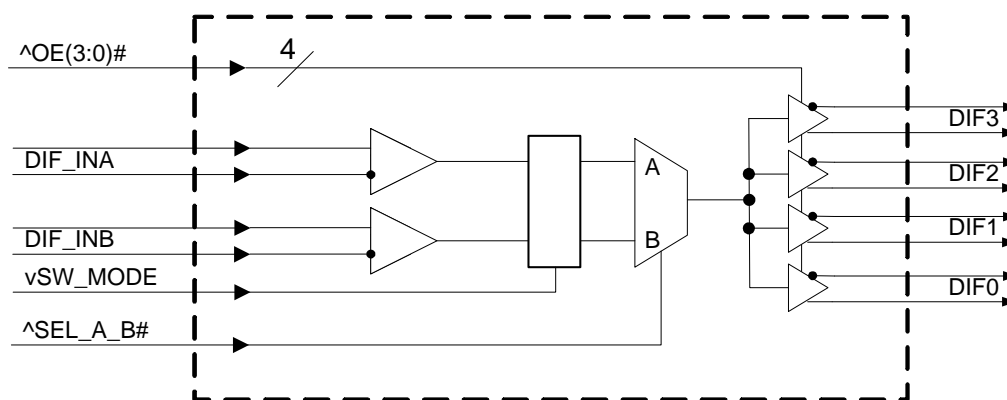

Pin Configuration

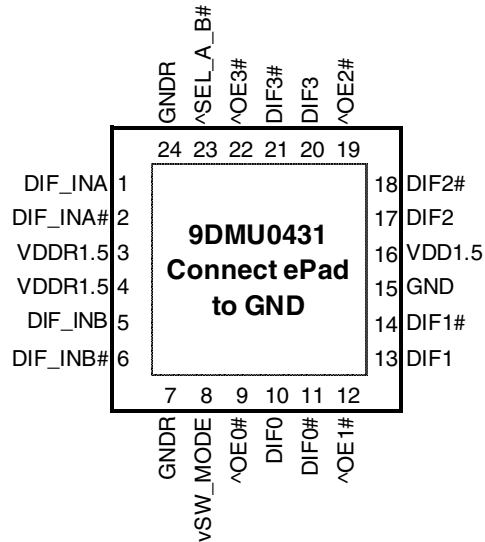

24 VFQFPN, 4x4 mm, 0.5mm pitch

^ prefix indicates internal 120KOhm pull up resistor
v prefix indicates internal 120KOhm pull down resistor

Power Management Table

OEx# Pin	DIF_IN	DIFx	
		True O/P	Comp. O/P
0	Running	Running	Running
1	Running	Low	Low

Power Connections

Pin Number		Description
VDD	GND	
3	24	Input A receiver analog
4	7	Input B receiver analog
16	15	DIF outputs

Pin Descriptions

Pin#	Pin Name	Type	Pin Description
1	DIF_INA	IN	HCSL Differential True input
2	DIF_INA#	IN	HCSL Differential Complement Input
3	VDDR1.5	PWR	1.5V power for differential input clock (receiver). This VDD should be treated as an Analog power rail and filtered appropriately.
4	VDDR1.5	PWR	1.5V power for differential input clock (receiver). This VDD should be treated as an Analog power rail and filtered appropriately.
5	DIF_INB	IN	HCSL Differential True input
6	DIF_INB#	IN	HCSL Differential Complement Input
7	GNDR	GND	Analog Ground pin for the differential input (receiver)
8	vSW_MODE	IN	Switch Mode. This pin selects either asynchronous or glitch-free switching of the mux. Use asynchronous mode if 0 or 1 of the input clocks is running. Use glitch-free mode if both input clocks are running. This pin has an internal pull down resistor of ~120kohms. 0 = asynchronous mode 1 = glitch-free mode
9	^OE0#	IN	Active low input for enabling DIF pair 0. This pin has an internal pull-up resistor. 1 =disable outputs, 0 = enable outputs
10	DIF0	OUT	Differential true clock output
11	DIF0#	OUT	Differential Complementary clock output
12	^OE1#	IN	Active low input for enabling DIF pair 1. This pin has an internal pull-up resistor. 1 =disable outputs, 0 = enable outputs
13	DIF1	OUT	Differential true clock output
14	DIF1#	OUT	Differential Complementary clock output
15	GND	GND	Ground pin.

Pin Descriptions (cont.)

Pin#	Pin Name	Type	Pin Description
16	VDD1.5	PWR	Power supply, nominally 1.5V
17	DIF2	OUT	Differential true clock output
18	DIF2#	OUT	Differential Complementary clock output
19	^OE2#	IN	Active low input for enabling DIF pair 2. This pin has an internal pull-up resistor. 1 =disable outputs, 0 = enable outputs
20	DIF3	OUT	Differential true clock output
21	DIF3#	OUT	Differential Complementary clock output
22	^OE3#	IN	Active low input for enabling DIF pair 3. This pin has an internal pull-up resistor. 1 =disable outputs, 0 = enable outputs
23	^SEL_A_B#	IN	Input to select differential input clock A or differential input clock B. This input has an internal pull-up resistor. 0 = Input B selected, 1 = Input A selected.
24	GNDR	GND	Analog Ground pin for the differential input (receiver)
25	EPAD	GND	Connect to Ground.

Test Loads

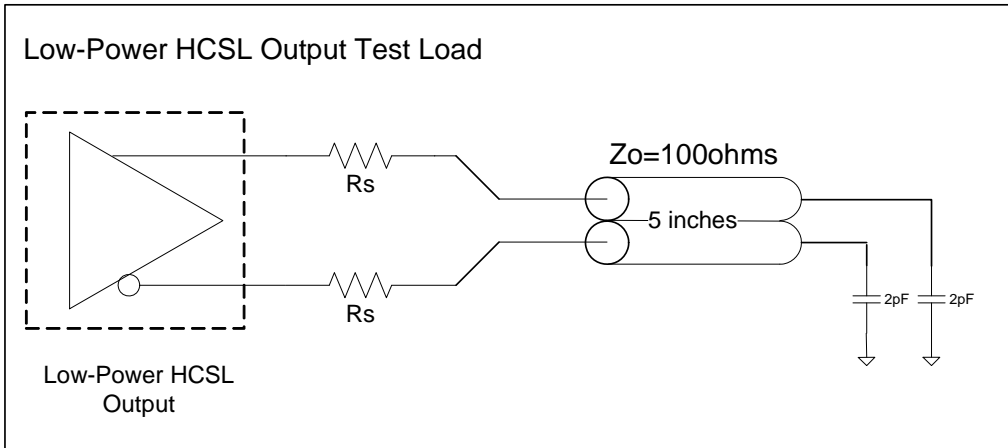

Alternate Differential Output Terminations

R_s	Z_o	Units
33	100	Ohms
27	85	

Driving LVDS

Driving LVDS

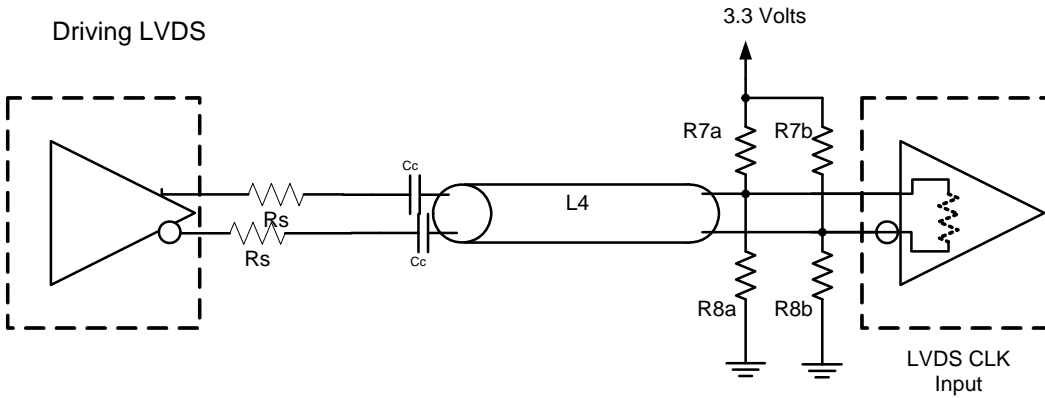

Driving LVDS inputs

Component	Value		Note
	Receiver has termination	Receiver does not have termination	
R7a, R7b	10K ohm	140 ohm	
R8a, R8b	5.6K ohm	75 ohm	
Cc	0.1 uF	0.1 uF	
Vcm	1.2 volts	1.2 volts	

Electrical Characteristics–Absolute Maximum Ratings

PARAMETER	SYMBOL	CONDITIONS	MIN	TYP	MAX	UNITS	NOTES
Supply Voltage	VDDx		-0.5		2	V	1,2
Input Voltage	V _{IN}		-0.5		V _{DD} +0.5	V	1,3
Input High Voltage, SMBus	V _{IHSMB}	SMBus clock and data pins			3.3	V	1
Storage Temperature	T _s		-65		150	°C	1
Junction Temperature	T _j				125	°C	1
Input ESD protection	ESD prot	Human Body Model	2000			V	1

¹Guaranteed by design and characterization, not 100% tested in production.

²Operation under these conditions is neither implied nor guaranteed.

³Not to exceed 2.0V.

Electrical Characteristics–Input/Supply/Common Parameters–Normal Operating Conditions

T_A = T_{AMB}, Supply Voltages per normal operation conditions, See Test Loads for Loading Conditions

PARAMETER	SYMBOL	CONDITIONS	MIN	TYP	MAX	UNITS	NOTES
Supply Voltage	VDDx	Supply voltage for core and analog	1.425	1.5	1.575	V	
Ambient Operating Temperature	T _{AMB}	Industrial range	-40	25	85	°C	1
Input High Voltage	V _{IH}	Single-ended inputs, except SMBus	0.75 V _{DD}		V _{DD} + 0.3	V	
Input Low Voltage	V _{IL}	Single-ended inputs, except SMBus	-0.3		0.25 V _{DD}	V	
Input Current	I _{IN}	Single-ended inputs, V _{IN} = GND, V _{IN} = VDD	-5		5	µA	
	I _{INP}	Single-ended inputs V _{IN} = 0 V; Inputs with internal pull-up resistors V _{IN} = VDD; Inputs with internal pull-down resistors	-200		200	µA	
Input Frequency	F _{in}		1		167	MHz	2
Pin Inductance	L _{pin}				7	nH	1
Capacitance	C _{IN}	Logic Inputs, except DIF_IN	1.5		5	pF	1
	C _{INDIF_IN}	DIF_IN differential clock inputs	1.5		2.7	pF	1,4
	C _{OUT}	Output pin capacitance			6	pF	1
Clk Stabilization	T _{STAB}	From V _{DD} Power-Up and after input clock stabilization or de-assertion of PD# to 1st clock			1	ms	1,2
Input SS Modulation Frequency PCIe	f _{MODINPCIe}	Allowable Frequency for PCIe Applications (Triangular Modulation)	30		33	kHz	
Input SS Modulation Frequency non-PCIe	f _{MODIN}	Allowable Frequency for non-PCIe Applications (Triangular Modulation)	0		66	kHz	
OE# Latency	t _{LATOE#}	DIF start after OE# assertion DIF stop after OE# deassertion	1		3	clocks	1,3
Tfall	t _F	Fall time of single-ended control inputs			5	ns	2
Trise	t _R	Rise time of single-ended control inputs			5	ns	2

¹Guaranteed by design and characterization, not 100% tested in production.

²Control input must be monotonic from 20% to 80% of input swing.

³Time from deassertion until outputs are >200 mV

⁴ DIF_IN input

Electrical Characteristics–Clock Input Parameters

TA = T_{AMB}, Supply Voltages per normal operation conditions, See Test Loads for Loading Conditions

PARAMETER	SYMBOL	CONDITIONS	MIN	TYP	MAX	UNITS	NOTES
Input High Voltage - DIF_IN	V _{IHDIF}	Differential inputs (single-ended measurement)	300	750	1150	mV	1
Input Low Voltage - DIF_IN	V _{ILDIF}	Differential inputs (single-ended measurement)	V _{SS} - 300	0	300	mV	1
Input Common Mode Voltage - DIF_IN	V _{COM}	Common Mode Input Voltage	200		725	mV	1
Input Amplitude - DIF_IN	V _{SWING}	Peak to Peak value (V _{IHDIF} - V _{ILDIF})	300		1450	mV	1
Input Slew Rate - DIF_IN	dv/dt	Measured differentially	0.35		8	V/ns	1,2
Input Leakage Current	I _{IN}	V _{IN} = V _{DD} , V _{IN} = GND	-5		5	uA	
Input Duty Cycle	d _{tin}	Measurement from differential waveform	45	50	55	%	1
Input Jitter - Cycle to Cycle	J _{DIFin}	Differential Measurement	0		150	ps	1

¹ Guaranteed by design and characterization, not 100% tested in production.

² Slew rate measured through +/-75mV window centered around differential zero

Electrical Characteristics–DIF Low-Power HCSL Outputs

TA = T_{AMB}, Supply Voltages per normal operation conditions, See Test Loads for Loading Conditions

PARAMETER	SYMBOL	CONDITIONS	MIN	TYP	MAX	UNITS	NOTES
Slew rate	dV/dt	Scope averaging on, fast setting	1.2	2.5	4.2	V/ns	1,2,3
Slew rate matching	ΔdV/dt	Slew rate matching, Scope averaging on		10	20	%	1,2,4
Voltage High	V _{HIGH}	Statistical measurement on single-ended signal using oscilloscope math function. (Scope averaging on)	550	761	850	mV	
Voltage Low	V _{LOW}		-150	33	150		
Max Voltage	V _{max}	Measurement on single ended signal using absolute value. (Scope averaging off)		800	1150	mV	
Min Voltage	V _{min}		-300	-1			
Vswing	Vswing	Scope averaging off	300	1457		mV	1,2
Crossing Voltage (abs)	V _{cross_abs}	Scope averaging off	250	404	550	mV	1,5
Crossing Voltage (var)	Δ-V _{cross}	Scope averaging off		15	140	mV	1,6

¹ Guaranteed by design and characterization, not 100% tested in production.

² Measured from differential waveform

³ Slew rate is measured through the Vswing voltage range centered around differential 0V. This results in a +/-150mV window around differential 0V.

⁴ Matching applies to rising edge rate for Clock and falling edge rate for Clock#. It is measured using a +/-75mV window centered on the average cross point where Clock rising meets Clock# falling. The median cross point is used to calculate the voltage thresholds the oscilloscope is to use for the edge rate calculations.

⁵ V_{cross} is defined as voltage where Clock = Clock# measured on a component test board and only applies to the differential rising edge (i.e. Clock rising and Clock# falling).

⁶ The total variation of all V_{cross} measurements in any particular system. Note that this is a subset of V_{cross_min/max} (V_{cross} absolute) allowed. The intent is to limit V_{cross} induced modulation by setting Δ-V_{cross} to be smaller than V_{cross} absolute.

Electrical Characteristics–Current Consumption

TA = T_{AMB}, Supply Voltages per normal operation conditions, See Test Loads for Loading Conditions

PARAMETER	SYMBOL	CONDITIONS	MIN	TYP	MAX	UNITS	NOTES
Operating Supply Current	I _{DD}	VDD, All outputs active @100MHz		19	27	mA	1
Powerdown Current	I _{DDP}	VDD, all outputs disabled		1.4	2.5	mA	1, 2

¹ Guaranteed by design and characterization, not 100% tested in production.

² Input clock stopped.

Electrical Characteristics–Output Duty Cycle, Jitter, Skew and PLL Characteristics

TA = T_{AMB}, Supply Voltages per normal operation conditions, See Test Loads for Loading Conditions

PARAMETER	SYMBOL	CONDITIONS	MIN	TYP	MAX	UNITS	NOTES
Duty Cycle Distortion	t _{DCD}	Measured differentially, Bypass Mode @100MHz	-1	-0.05	1	%	1,3
Skew, Input to Output	t _{pdBYP}	Bypass Mode, V _T = 50%	2046	2864	4010	ps	1
Skew, Output to Output	t _{sk3}	V _T = 50%		19	50	ps	1,4
Jitter, Cycle to cycle	t _{cyC-cyC}	Additive Jitter in Bypass Mode		0.1	5	ps	1,2

¹ Guaranteed by design and characterization, not 100% tested in production.

Measured from differential waveform

⁴ All outputs at default slew rate

⁵ The MIN/TYP/MAX values of each BW setting track each other, i.e., Low BW MAX will never occur with Hi BW MIN.

Electrical Characteristics–Phase Jitter Parameters

TA = T_{AMB}, Supply Voltages per normal operation conditions, See Test Loads for Loading Conditions

PARAMETER	SYMBOL	CONDITIONS	MIN	TYP	MAX	INDUSTRY LIMIT	UNITS	Notes
Additive Phase Jitter, Bypass Mode	t _{jphPCIEG1}	PCIe Gen 1		1.3	5	N/A	ps (p-p)	1,2,3,5
	t _{jphPCIEG2}	PCIe Gen 2 Lo Band 10kHz < f < 1.5MHz		0.1	0.5	N/A	ps (rms)	1,2,3,4,5
		PCIe Gen 2 High Band 1.5MHz < f < Nyquist (50MHz)		0.1	0.6	N/A	ps (rms)	1,2,3,4
	t _{jphPCIEG3}	PCIe Gen 3 (PLL BW of 2-4 or 2-5MHz, CDR = 10MHz)		0.170	0.3	N/A	ps (rms)	1,2,3,4
	t _{jph125M0}	125MHz, 1.5MHz to 10MHz, -20dB/decade rollover < 1.5MHz, -40db/decade rolloff > 10MHz		365	380	N/A	fs (rms)	1,6
t _{jph125M1}	125MHz, 12KHz to 20MHz, -20dB/decade rollover < 12kHz, -40db/decade rolloff > 20MHz		535	550	N/A	fs (rms)	1,6	

¹ Guaranteed by design and characterization, not 100% tested in production.

² See <http://www.pcisig.com> for complete specs

³ Sample size of at least 100K cycles. This figures extrapolates to 108ps pk-pk @ 1M cycles for a BER of 1-12.

⁴ For RMS figures, additive jitter is calculated by solving the following equation: Additive jitter = SQRT[(total jitter)² - (input jitter)²]

⁵ Driven by 9FGU0831 or equivalent

⁶ Rohde&Schartz SMA100

Marking Diagrams

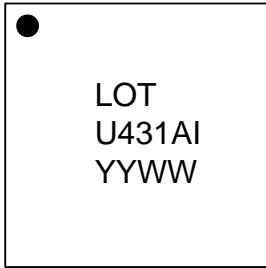

Notes:

1. "LOT" denotes the lot number.
2. "YYWW" is the last two digits of the year and week that the part was assembled.
3. Line 2: truncated part number
4. "I" denotes industrial temperature grade.

Thermal Characteristics

PARAMETER	SYMBOL	CONDITIONS	PKG	TYP VALUE	UNITS	NOTES
Thermal Resistance	θ_{JC}	Junction to Case	NLG24	42	°C/W	1
	θ_{Jb}	Junction to Base		2.4	°C/W	1
	θ_{JA0}	Junction to Air, still air		39	°C/W	1
	θ_{JA1}	Junction to Air, 1 m/s air flow		33	°C/W	1
	θ_{JA3}	Junction to Air, 3 m/s air flow		28	°C/W	1
	θ_{JA5}	Junction to Air, 5 m/s air flow		27	°C/W	1

¹ePad soldered to board

Package Outline and Package Dimensions (NLG24)

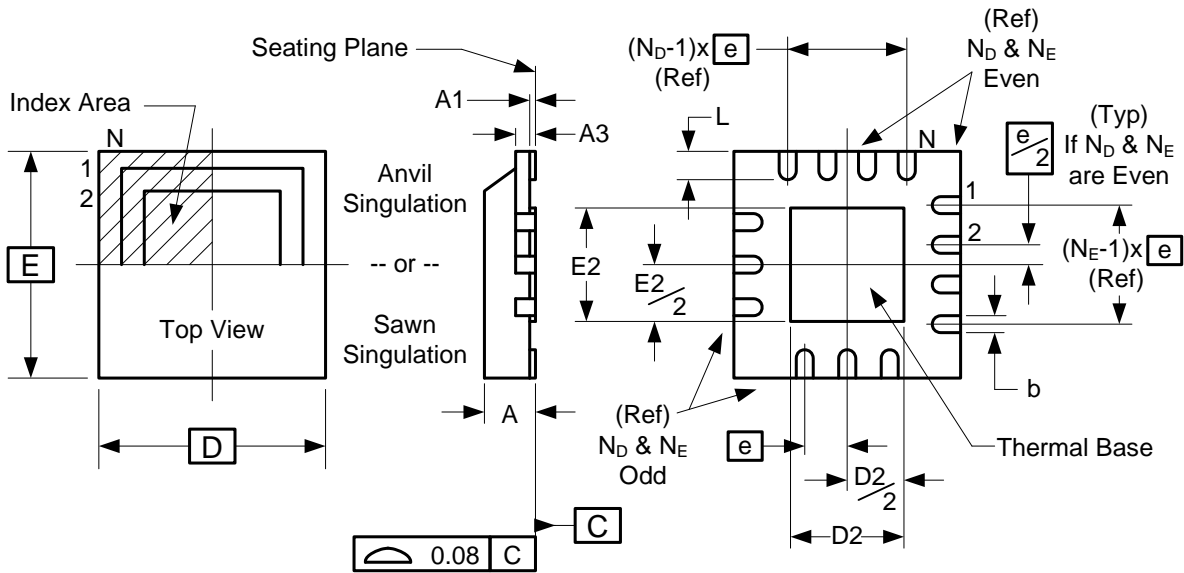

Symbol	Millimeters	
	Min	Max
A	0.80	1.00
A1	0	0.05
A3	0.25 Reference	
b	0.18	0.30
e	0.50 BASIC	
D x E BASIC	4.00 x 4.00	
D2 MIN./MAX.	2.3	2.55
E2 MIN./MAX.	2.3	2.55
L MIN./MAX.	0.30	0.50
N	24	
N _D	6	
N _E	6	

Ordering Information

Part / Order Number	Shipping Packaging	Package	Temperature
9DMU0431AKILF	Tubes	24-pin VFQFPN	-40 to +85° C
9DMU0431AKILFT	Tape and Reel	24-pin VFQFPN	-40 to +85° C

"LF" to the suffix denotes Pb-Free configuration, RoHS compliant.

"A" is the device revision designator (will not correlate with the datasheet revision).

Revision History

Rev.	Initiator	Issue Date	Description	Page #
A	RDW	9/24/2014	1. Updated additive phase jitter and General Description 2. Move to final	1,7



Corporate Headquarters
6024 Silver Creek Valley Road
San Jose, CA 95138 USA

Sales
1-800-345-7015 or 408-284-8200
Fax: 408-284-2775
www.IDT.com

Tech Support
email: clocks@idt.com

DISCLAIMER Integrated Device Technology, Inc. (IDT) and its subsidiaries reserve the right to modify the products and/or specifications described herein at any time and at IDT's sole discretion. All information in this document, including descriptions of product features and performance, is subject to change without notice. Performance specifications and the operating parameters of the described products are determined in the independent state and are not guaranteed to perform the same way when installed in customer products. The information contained herein is provided without representation or warranty of any kind, whether express or implied, including, but not limited to, the suitability of IDT's products for any particular purpose, an implied warranty of merchantability, or non-infringement of the intellectual property rights of others. This document is presented only as a guide and does not convey any license under intellectual property rights of IDT or any third parties.

IDT's products are not intended for use in applications involving extreme environmental conditions or in life support systems or similar devices where the failure or malfunction of an IDT product can be reasonably expected to significantly affect the health or safety of users. Anyone using an IDT product in such a manner does so at their own risk, absent an express, written agreement by IDT.

Integrated Device Technology, IDT and the IDT logo are registered trademarks of IDT. Product specification subject to change without notice. Other trademarks and service marks used herein, including protected names, logos and designs, are the property of IDT or their respective third party owners.

Copyright ©2014 Integrated Device Technology, Inc.. All rights reserved.

Mouser Electronics

Authorized Distributor

Click to View Pricing, Inventory, Delivery & Lifecycle Information:

[IDT \(Integrated Device Technology\):](#)

[9DMU0431AKILFT](#) [9DMU0431AKILF](#)

Компания «Life Electronics» занимается поставками электронных компонентов импортного и отечественного производства от производителей и со складов крупных дистрибьюторов Европы, Америки и Азии.

С конца 2013 года компания активно расширяет линейку поставок компонентов по направлению коаксиальный кабель, кварцевые генераторы и конденсаторы (керамические, пленочные, электролитические), за счёт заключения дистрибьюторских договоров

Мы предлагаем:

- Конкурентоспособные цены и скидки постоянным клиентам.
- Специальные условия для постоянных клиентов.
- Подбор аналогов.
- Поставку компонентов в любых объемах, удовлетворяющих вашим потребностям.
- Приемлемые сроки поставки, возможна ускоренная поставка.
- Доставку товара в любую точку России и стран СНГ.
- Комплексную поставку.
- Работу по проектам и поставку образцов.
- Формирование склада под заказчика.
- Сертификаты соответствия на поставляемую продукцию (по желанию клиента).
- Тестирование поставляемой продукции.
- Поставку компонентов, требующих военную и космическую приемку.
- Входной контроль качества.
- Наличие сертификата ISO.

В составе нашей компании организован Конструкторский отдел, призванный помогать разработчикам, и инженерам.

Конструкторский отдел помогает осуществить:

- Регистрацию проекта у производителя компонентов.
- Техническую поддержку проекта.
- Защиту от снятия компонента с производства.
- Оценку стоимости проекта по компонентам.
- Изготовление тестовой платы монтаж и пусконаладочные работы.



Тел: +7 (812) 336 43 04 (многоканальный)

Email: org@lifeelectronics.ru