

Preliminary Product Specification

100GHz Ultra-High Speed Balanced Photodetector

BPDV412xRy-WF-zz

PRODUCT FEATURES

- Ultra-high bandwidth of >100GHz
- Based on a waveguide-integrated photodetector chip
- Excellent uniformity of photodiodes
- Integrated termination
- C-band performance
- SMF-28 optical input
- Temperature: 0°C to +75°C
- Supply voltage: +3.5/-3.5 V
- F16 package with W1-connector®
- Available as dual-pair or quad-set
- Offered also as 90GHz version



APPLICATIONS

- Coherent Test & Measurement Systems
- Next Generation DWDM Networks
- Transmission Systems with >1Tb/s data-rate
- Research and Development
- Detection of up to 160 Gbaud x-QAM signals

The BPDV412x balanced photodetector is a compact module consisting of two optimized 100 GHz waveguide-integrated photodiodes on a single chip. As a single device, this configuration ensures excellent uniformity of the paired photodiodes performance; biasing is achieved via an integrated biasing network. Due to the optimized design of waveguide and Photodiode, even at high optical power, a linear frequency response can be guaranteed. The integrated termination allows an excellent match of the electrical output signal. Custom configurations are available, such as BPDV matched pairs, and quad sets, including connector customization and fiber matching to enable coherent detection. A 90 GHz version of this module is also available upon request.

I Ordering Information

BPDV412xRy-WF-zz

- x: 0: f3dB > 90 GHz
 1: f3dB > 100 GHz

- Ry: R = single balanced detector
 RM = matched pair of balanced detectors
 RQ = matched quad-set of balanced detectors

- zz: SA = SC/APC
 other options upon request

II Block Diagram

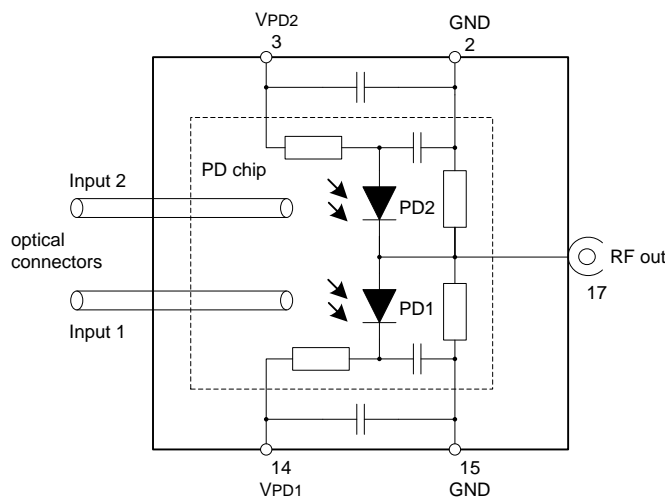

Figure 1 Block Diagram of BPDV412xRy-WF-zz

III Absolute Maximum Ratings

Parameter	Symbol	Condition	Min.	Typ.	Max.	Unit
Photodiode bias voltage	V_{PD1}		0		4	V
	V_{PD2}		-4		0	
Maximum average optical input power	P_{OPT}	continuous wave (CW)			16	dBm
Electro static discharge	V_{ESD}	C=100 pF, R= 1.5 kΩ HBM	-250		250	V

IV Environmental Conditions

Parameter	Symbol	Condition	Min.	Typ.	Max.	Unit
Storage temperature	T_{storage}	non condensing	-40		+85	°C
Operating case temperature range	T_{CASE}		0		+75	°C
Relative humidity range	RH	non condensing	5		85	%

V Operating Conditions

Parameter	Symbol	Condition	Min.	Typ.	Max.	Unit
Operating wavelength range	λ		1525		1570	nm
Average optical input power range	P_{OPT}				13	dBm
Photodiode bias voltage	V_{PD1} V_{PD2}		2.5 -3.8	3.3 -3.3	3.8 -2.5	V

VI Electro-Optical Specifications¹

Parameter	Symbol	Condition	Min.	Typ.	Max.	Unit
Photodiode DC responsivity	R	optimum polarization	0.23	0.27		A/W
Imbalance of responsivity	Imb	$\text{Imb} = 10 \cdot \log_{10}(R_{\text{PD1}}/R_{\text{PD2}}) $		0.15	0.5	
Polarization dependent loss	PDL			0.75	0.95	dB
Optical return loss	ORL		27			dB
3dB cut-off frequency (BPDV4121)	$f_{3\text{dB}}$		100	105		GHz
3dB cut-off frequency (BPDV4120)	$f_{3\text{dB}}$		90	95		GHz
Output Reflection Coefficient	S22	0...35 GHz		-10	-9	dB
		35...50 GHz		-8	-7	
		50...67 GHz		-5	-4.0	
CMRR		$\text{CMRR} = 20 \cdot \log_{10} (S_{21} - S_{31}) / (S_{21} + S_{31}) $ 0...67 GHz		14		dB
Photodiode dark current	I_{dark}			10	200	nA
Skew				1.0		ps
Skew (inter module)				4		ps
Notes:						
1 $\lambda = 1550 \text{ nm}$, $V_{\text{PD}} = \pm 3.3 \text{ V}$, $T = 25^\circ\text{C}$, $P_{\text{OPT}} = +3 \text{ dBm}$						

VII Typical Performance

Frequency response

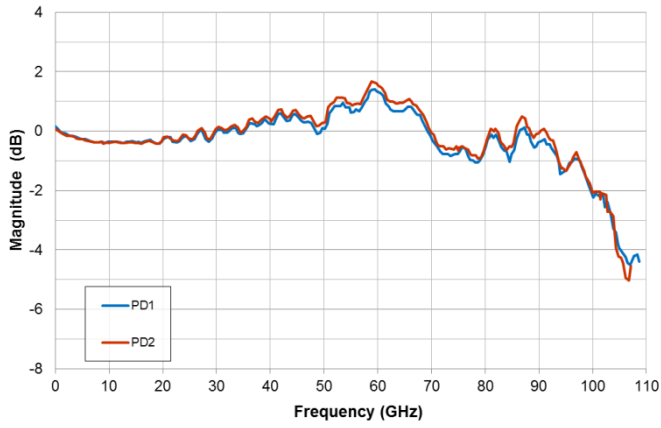

Figure 2 Frequency response of the BPDV4121R measured with Heterodyne measurement setup

VIII Mechanical Specifications

All dimensions are in mm.

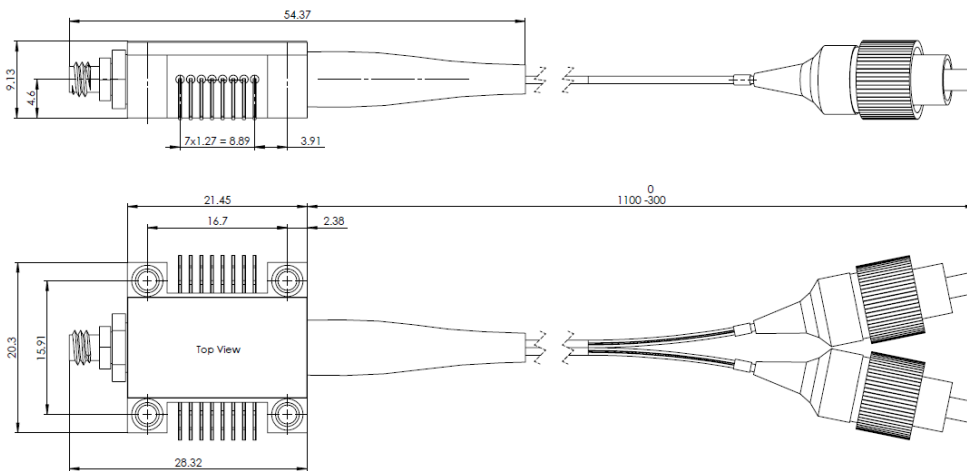
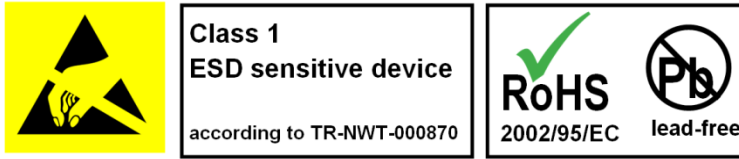

Figure 3. Mechanical dimensions of BPDV412xRy-WF-zz

IX General Notices



Notice

Stresses greater than those listed under “Absolute Maximum Ratings” may cause permanent damage to the device. This is a stress rating only and functional operation of the device at these or any other conditions above those indicated in the operations section for extended periods of time may affect reliability.

The inherent design of this component causes it to be sensitive to electrostatic discharge (ESD). To prevent ESD-induced damage and/or degradation to equipment, take normal ESD precautions when handling this product

X Notes

Any trademarks used in this document are properties of their respective owners. Finisar Corporation reserves the right to make changes without notice.

XI Revision History

Document Number: **TBD**

Revision	Date	Description
A1	2017-03-10	Initial Release.
A2	2017-03-17	Updated specifications

XII For More Information

Finisar Corporation
 1389 Moffett Park Drive
 Sunnyvale, CA 94089-1133
 Tel: +1-408-548-1000
 Fax: +1-408-541-6138
high-speed-detectors@finisar.com
sales@finisar.com
www.finisar.com

Компания «Life Electronics» занимается поставками электронных компонентов импортного и отечественного производства от производителей и со складов крупных дистрибьюторов Европы, Америки и Азии.

С конца 2013 года компания активно расширяет линейку поставок компонентов по направлению коаксиальный кабель, кварцевые генераторы и конденсаторы (керамические, пленочные, электролитические), за счёт заключения дистрибьюторских договоров

Мы предлагаем:

- Конкуренспособные цены и скидки постоянным клиентам.
- Специальные условия для постоянных клиентов.
- Подбор аналогов.
- Поставку компонентов в любых объемах, удовлетворяющих вашим потребностям.
- Приемлемые сроки поставки, возможна ускоренная поставка.
- Доставку товара в любую точку России и стран СНГ.
- Комплексную поставку.
- Работу по проектам и поставку образцов.
- Формирование склада под заказчика.
- Сертификаты соответствия на поставляемую продукцию (по желанию клиента).
- Тестирование поставляемой продукции.
- Поставку компонентов, требующих военную и космическую приемку.
- Входной контроль качества.
- Наличие сертификата ISO.

В составе нашей компании организован Конструкторский отдел, призванный помогать разработчикам, и инженерам.

Конструкторский отдел помогает осуществить:

- Регистрацию проекта у производителя компонентов.
- Техническую поддержку проекта.
- Защиту от снятия компонента с производства.
- Оценку стоимости проекта по компонентам.
- Изготовление тестовой платы монтаж и пусконаладочные работы.



Тел: +7 (812) 336 43 04 (многоканальный)

Email: org@lifeelectronics.ru