

## LTR-303ALS-01

### Digital Ambient Light Sensor

#### Features

- I<sup>2</sup>C interface (Fast Mode @ 400kbit/s)
- Ultra-small 6-pin ChipLED package  
2.0mm(L), 2.0mm(B), 0.7mm(H)
- Built-in temperature compensation circuit
- Low active power consumption with standby mode
- Supply voltage range from 2.4V to 3.6V capable of 1.7V logic voltage
- Operating temperature range from -30°C to +70°C
- RoHS and Halogen free compliant
- Close to human eye spectral response
- Immunity to IR / UV Light Source
- Automatically rejects 50 / 60 Hz lightings flicker
- Full dynamic range from 0.01 lux to 64k lux
- 16-bit effective resolution

#### Applications

- Back-lighting Control in mobile/portable devices
- Touch Panel Control in mobile/portable devices

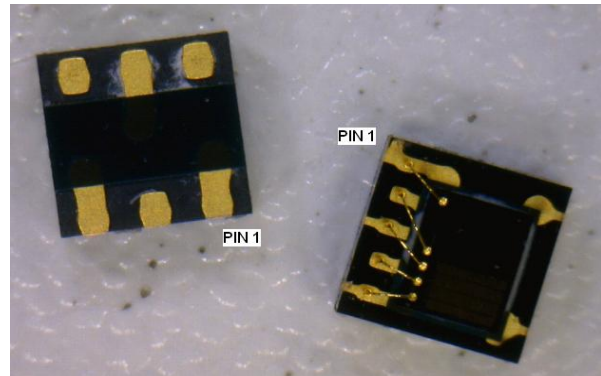

#### Description

The LTR-303ALS-01 is a low voltage I<sup>2</sup>C digital light sensor [ALS] in a low cost miniature chipled lead-free surface mount package. This sensor converts light intensity to a digital output signal capable of direct I<sup>2</sup>C interface. It provides a linear response over a wide dynamic range from 0.01 lux to 64k lux and is well suited to applications under high ambient brightness. There are altogether six gain settings (1X, 2X, 4X, 8X, 48X and 96X) available for user to configure.

The sensor supports an interrupt feature that removes the need to poll the sensor for a reading which improves system efficiency. The sensor also supports several features that help to minimize the occurrence of false triggering. This CMOS design and factory-set one time trimming capability ensure minimal sensor-to-sensor variations for ease of manufacturability to the end customers.

Part Number	Packaging Type	Package	Quantity
LTR-303ALS-01	Tape and Reel	6-pin chipled package	2500

## 1. Outline Dimensions

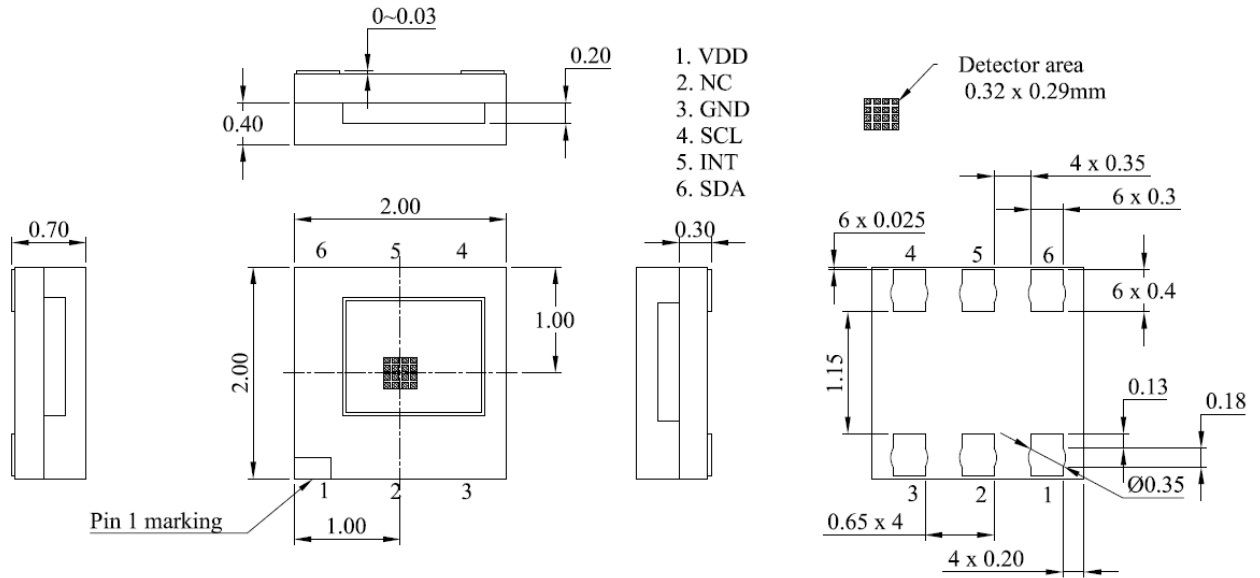

1. All dimensions in mm
2. Tolerances is +/-0.2
3. LTC reserve the right to to change the drawing till final datasheet release

## 2. Functional Block Diagram

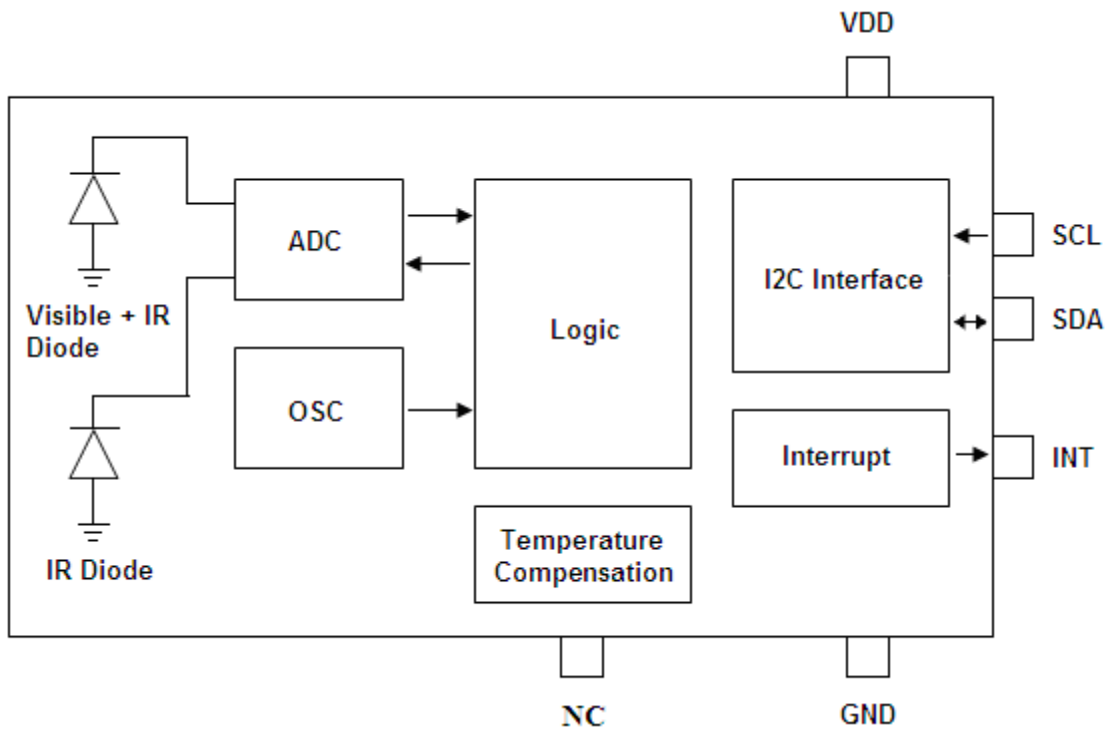

## 3. Application Circuit

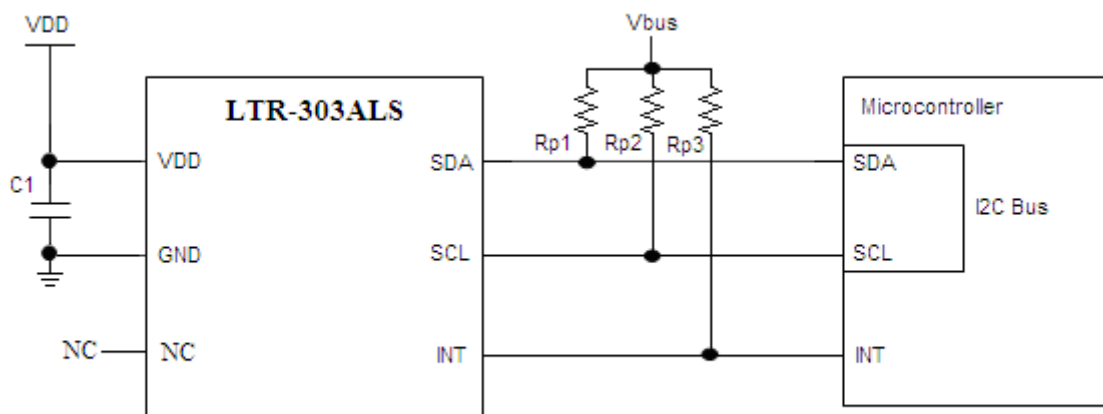

## I/O Pins Configuration Table

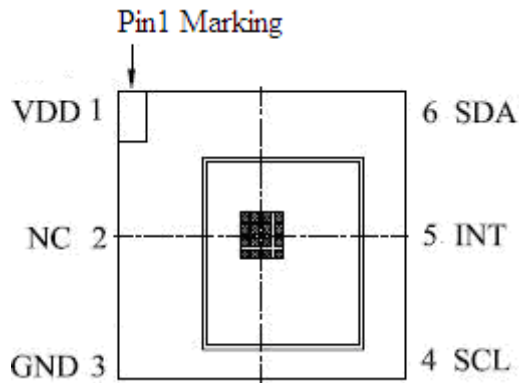

Pin	I/O Type	Symbol	Description
1		VDD	Power Supply Voltage
2		NC	No connection to this pin
3		GND	Ground
4	I	SCL*	I <sup>2</sup> C serial clock. This pin is an open drain input.
5	O	INT*	Level Interrupt Pin. This pin is an open drain output.
6	I/O	SDA*	I <sup>2</sup> C serial data. This pin is an open drain input / output.

\* Note: For noisy environment, add 10pF capacitor from signal to GND for additional noise filtering.

## Recommended Application Circuit Components

Component	Recommended Value
Rp1, Rp2, Rp3 [1]	1 kΩ to 10 kΩ
C1	1uF ± 20%, X7R / X5R Ceramic

[1] Selection of pull-up resistors value is dependent on bus capacitance values. For more details, please refer to I2C Specifications: [http://www.nxp.com/documents/user\\_manual/UM10204.pdf](http://www.nxp.com/documents/user_manual/UM10204.pdf)

## 4. Rating and Specification

### Absolute Maximum Ratings at Ta = 25°C

Parameter	Symbol	Rating	Unit
Supply Voltage	VDD	3.8	V
Digital Voltage Range	SCL, SDA, INT	-0.5 to 3.8	V
Digital Output Current	SCL, SDA, INT	-1 to 20	mA
Storage Temperature	T <sub>stg</sub>	-40 to 100	°C

Note: Exceeding these ratings could cause damage to the sensor. All voltages are with respect to ground. Currents are positive into, negative out of the specified terminal.

### Recommended Operating Conditions

Description	Symbol	Min.	Typ.	Max.	Unit
Supply Voltage	VDD	2.4		3.6	V
Interface Bus Power Supply Voltage	V <sub>IO</sub>	1.7		3.6	V
I <sup>2</sup> C Bus Input Pin High Voltage	V <sub>IH</sub> SCL, V <sub>IH</sub> SDA	1.2			V
I <sup>2</sup> C Bus Input Pin Low Voltage	V <sub>IL</sub> SCL, V <sub>IL</sub> SDA			0.6	V
Operating Temperature	T <sub>ope</sub>	-30		70	°C

## Electrical & Optical Specifications

All specifications are at VDD = 3.0V, T<sub>ope</sub> = 25°C, unless otherwise noted.

Parameter	Min.	Typ.	Max.	Unit	Condition
Active Supply Current			220	uA	Active Mode T <sub>ope</sub> = 25°C, VDD=3.6V Integration Time : 100ms Measurement rate : 200ms
Standby Current			5	uA	Standby / Sleep Mode
Initial Startup Time	100			ms	(Note 1)
Wakeup Time from Standby			10	ms	(Note 1)

### Light Sensor

Parameter	Min.	Typ.	Max.	Unit	Condition
Full Scale ADC Count			65535	count	
Dark ADC Count	0		6	count	Ch0, Lux = 0
	0		6	count	Ch1, Lux = 0
ADC Count (Gain = 96X) @200Lux	3250		6100	count	Ch0 (see note 2) white LED 200 Lux Integration Time : 50ms Measurement Time : 100ms
	1050		1950	count	Ch1 (see note 2) White LED 200 Lux Integration Time : 50ms Measurement Time : 100ms
	0.15		0.35	Ratio	Ch1/(Ch0 + Ch1)

**Notes:**

**1. Startup Sequence**

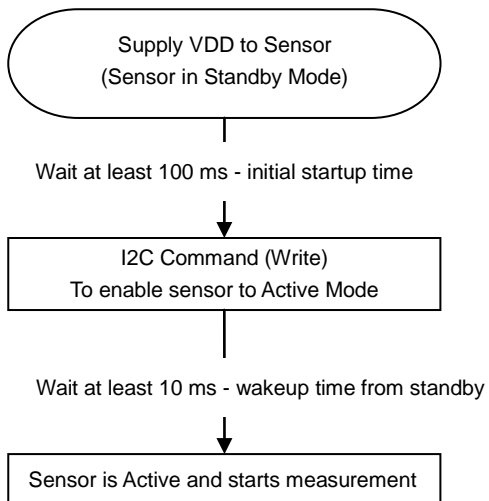

**2. LiteOn white LED color temperature 10000K.**

## Typical Performance Curve

All specifications are at  $V_{DD} = 3.0V$ ,  $T_{ope} = 25^{\circ}C$ , unless otherwise noted.

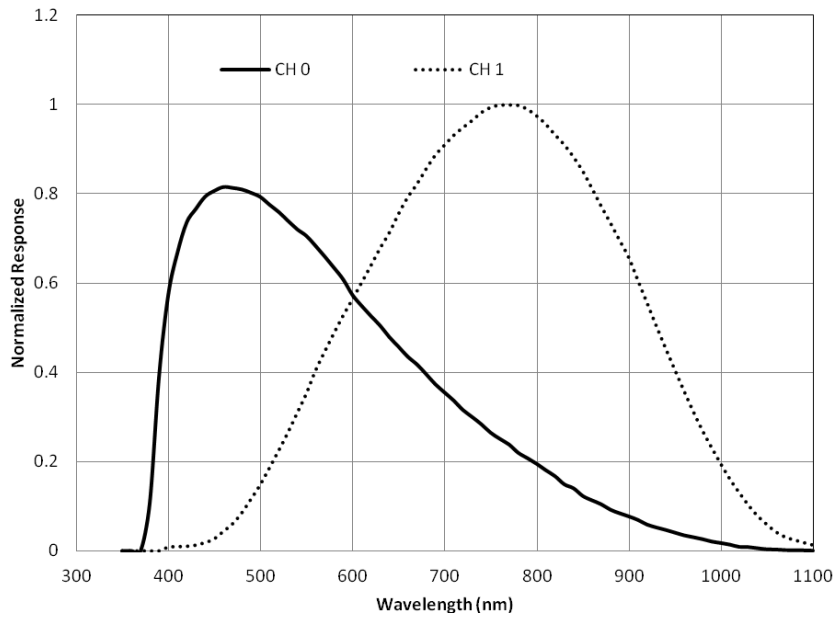

Figure 1: Normalized Spectral Response

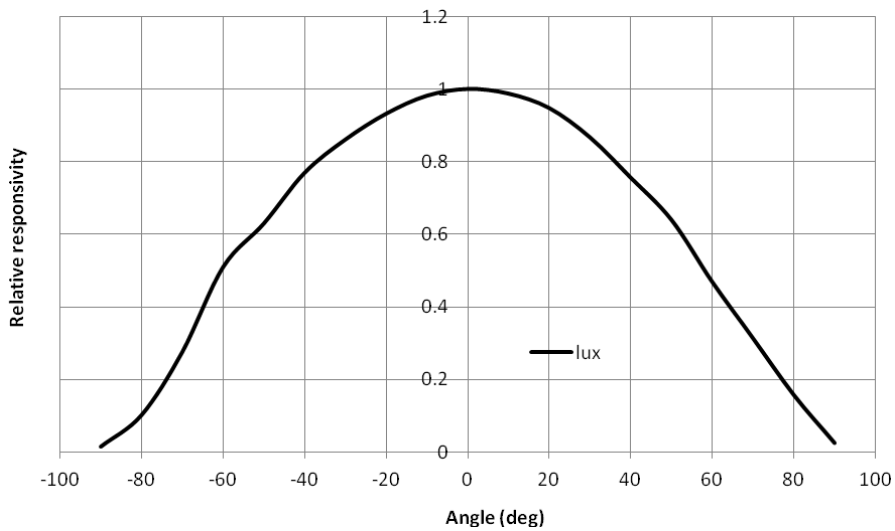

Figure 2 : Viewing angle



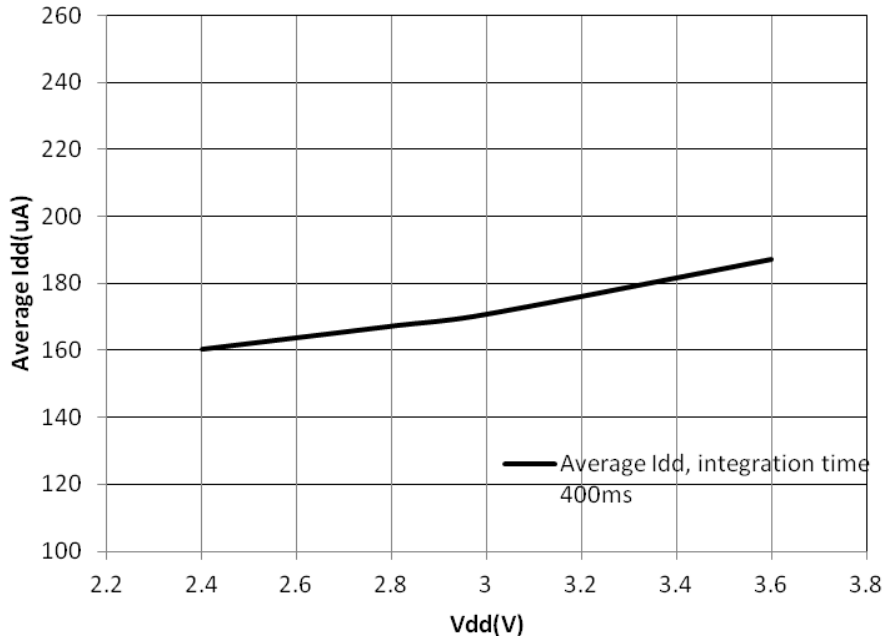

Figure 3 : Vdd versus Average Idd

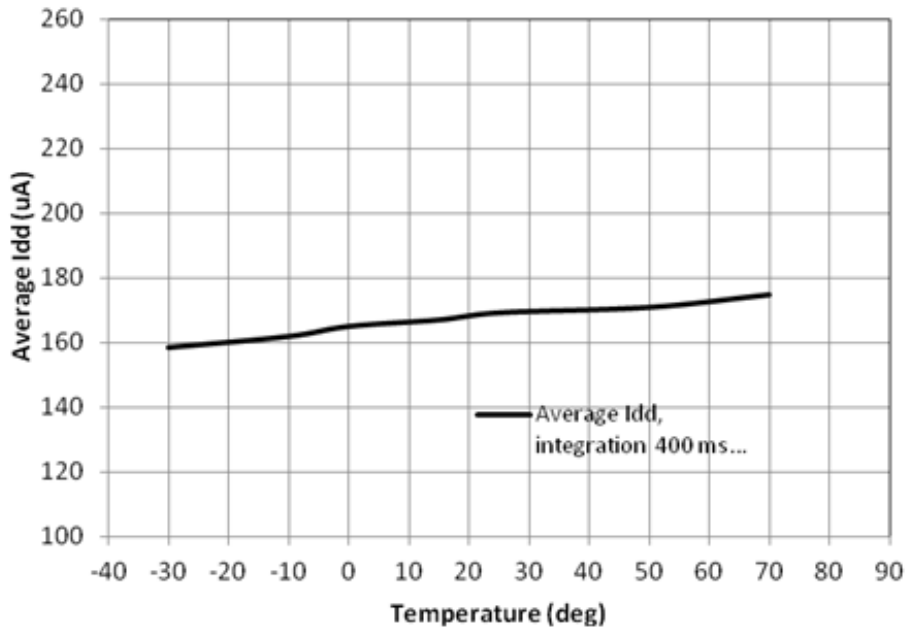

Figure 4 : Average Idd versus temperature

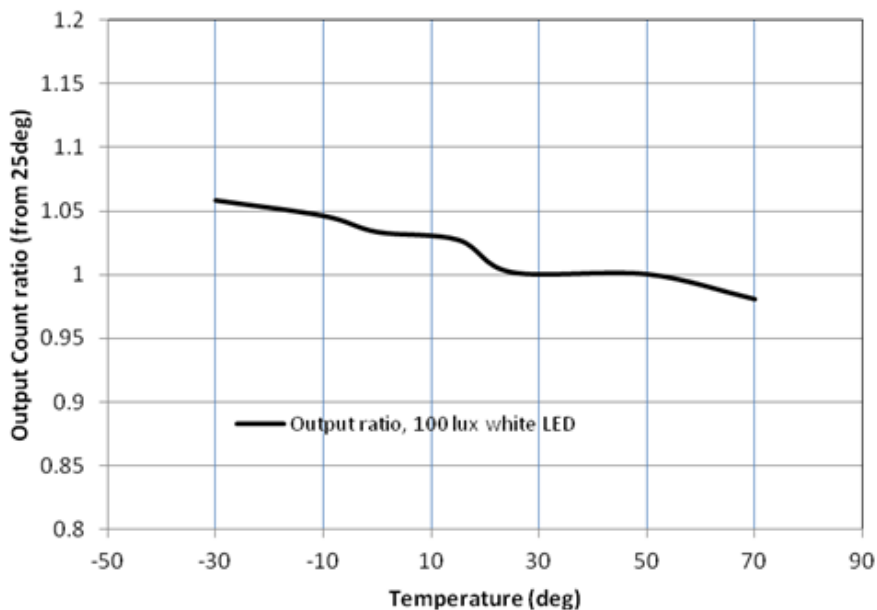

Figure 5 : Output count ratio versus temperature

### Lux Formula

Refer to Appendix A for the lux formula

## AC Electrical Characteristics

All specifications are at VBus = 1.8V, T<sub>ope</sub> = 25°C, unless otherwise noted.

Parameter	Symbol	Min.	Max.	Unit
SCL clock frequency	$f_{SCL}$	1	400	kHz
Bus free time between a STOP and START condition	$t_{BUF}$	1.3		us
Hold time (repeated) START condition. After this period, the first clock pulse is generated	$t_{HD;STA}$	0.6		us
LOW period of the SCL clock	$t_{LOW}$	1.3		us
HIGH period of the SCL clock	$t_{HIGH}$	0.6		us
Set-up time for a repeated START condition	$t_{SU;STA}$	0.6		us
Set-up time for STOP condition	$t_{SU;STO}$	0.6		us
Rise time of both SDA and SCL signals	$t_r$	30	300	ns
Fall time of both SDA and SCL signals	$t_f$	30	300	ns
Data hold time	$t_{HD;DAT}$	0.3	0.9	us
Data setup time	$t_{SU;DAT}$	100		ns
Pulse width of spikes which must be suppressed by the input filter	$t_{SP}$	0	50	ns

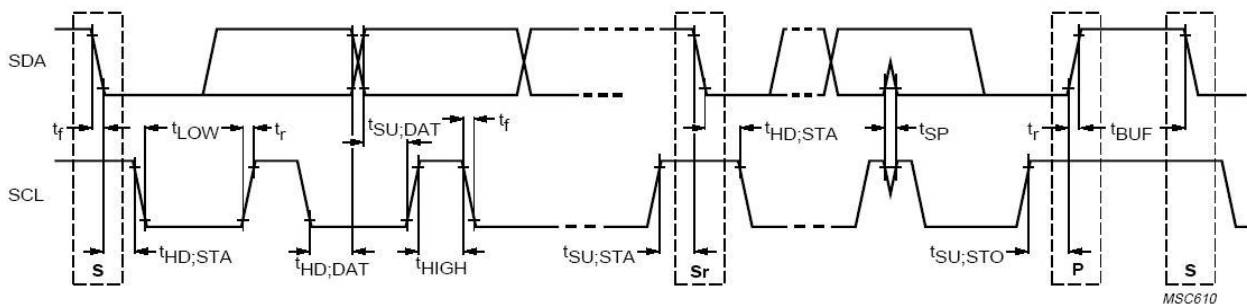

Definition of timing for I<sup>2</sup>C bus

## 5. Principles of Operation

### I2C Protocols

· I2C Write Protocol (type 1):

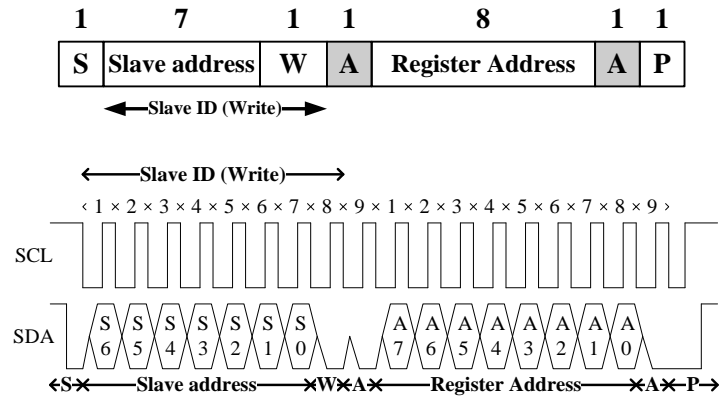

· I2C Write Protocol (type 2):

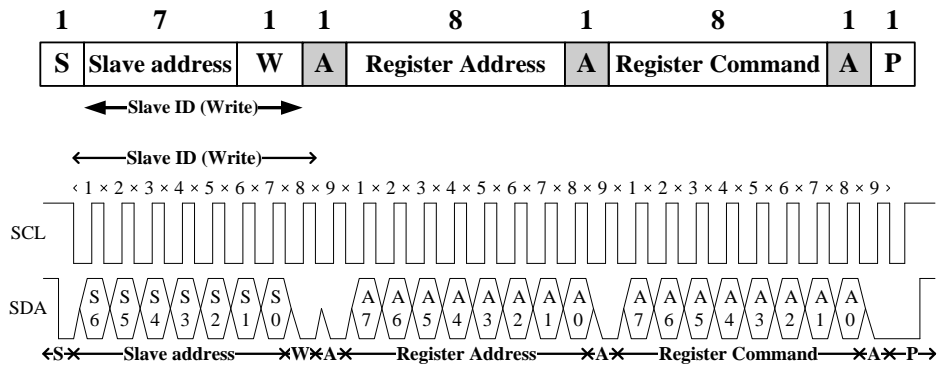

· I2C Read Protocol:

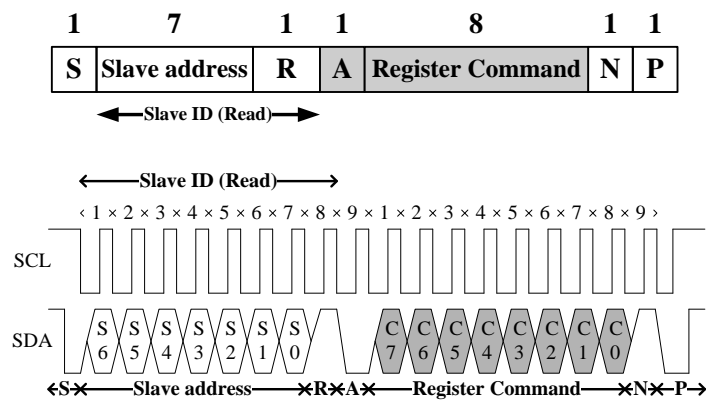

· I2C Read (Combined format) Protocol:

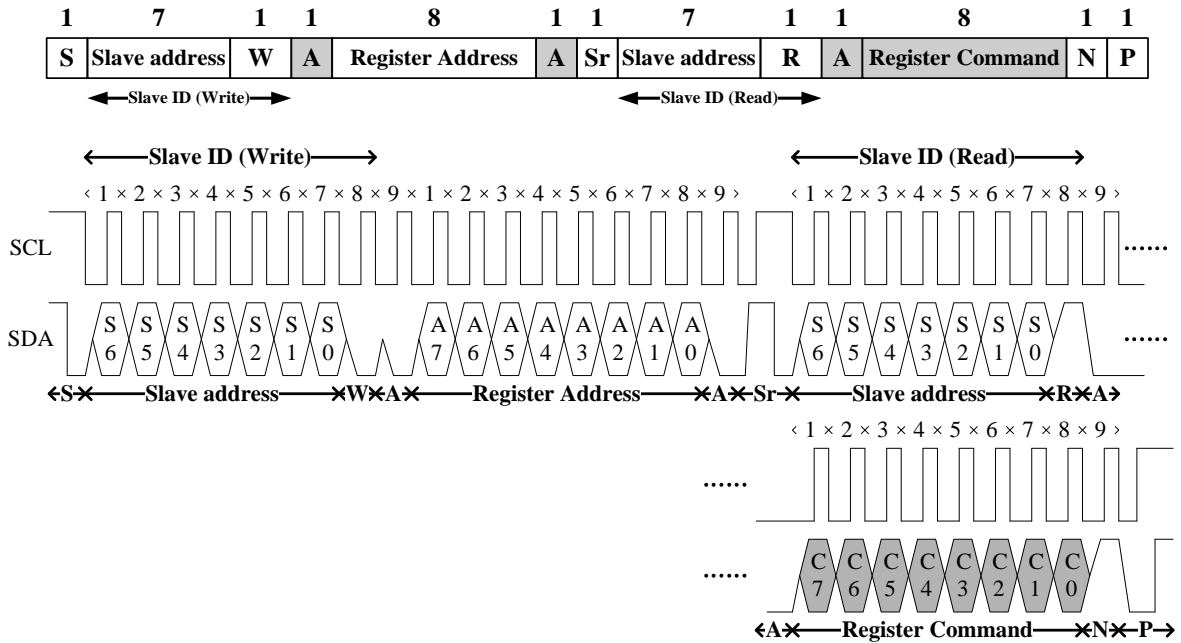

**A** Acknowledge (0 for an ACK)  
**S** Start condition  
**P** Stop condition  
**W** Write (0 for writing)  
 Slave-to-master

**N** Non-Acknowledge(1 for an NACK)  
**Sr** Repeated Start condition  
**R** Read (1 for read)  
 Master-to-Slave

## I2C Slave Address

The 7 bits slave address for this sensor is 0x29H. A read/write bit should be appended to the slave address by the master device to properly communicate with the sensor.

I2C Slave Address									
Command Type	(0x29H)							W/R	value
	Bit7	Bit6	Bit5	Bit4	Bit3	Bit2	Bit1	Bit0	
Write	0	1	0	1	0	0	1	0	0x52H
Read	0	1	0	1	0	0	1	1	0x53H

## Register Set

Addr	R / W	Register Name	Description	Reset Value
0x80	R / W	ALS_CONTR	ALS operation mode control SW reset	0x00
0x85	R / W	ALS_MEAS_RATE	ALS measurement rate in active mode	0x01
0x86	R	PART_ID	Part Number ID and Revision ID	0xA0
0x87	R	MANUFAC_ID	Manufacturer ID	0x05
0x88	R	ALS_DATA_CH1_0	ALS measurement CH1 data, lower byte	0x00
0x89	R	ALS_DATA_CH1_1	ALS measurement CH1 data, upper byte	0x00
0x8A	R	ALS_DATA_CH0_0	ALS measurement CH0 data, lower byte	0x00
0x8B	R	ALS_DATA_CH0_1	ALS measurement CH0 data, upper byte	0x00
0x8C	R	ALS_STATUS	ALS new data status	0x00
0x8F	R / W	INTERRUPT	Interrupt settings	0x08
0x97	R / W	ALS_THRES_UP_0	ALS interrupt upper threshold, lower byte	0xFF
0x98	R / W	ALS_THRES_UP_1	ALS interrupt upper threshold, upper byte	0xFF
0x99	R / W	ALS_THRES_LOW_0	ALS interrupt lower threshold, lower byte	0x00
0x9A	R / W	ALS_THRES_LOW_1	ALS interrupt lower threshold, upper byte	0x00
0x9E	R / W	INTERRUPT PERSIST	ALS Interrupt persist setting	0x00

### Notes:

- 1) When reading ALS data registers, read sequence should always be from lower address to higher address (E.g. For ALS data, Ch1 data should be read first followed by Ch0 data. Read sequence should be 0x88, 0x89, 0x8A, 0x8B. When 0x8B is read, all four ALS data registers will be populated with new set of data).
- 2) When setting of INTERRUPT register (addr 0x8F) is necessary, it should be done before the device is in Active mode.

## ALS\_CONTR Register (0x80)

The ALS\_CONTR register controls the ALS operation modes and software (SW) reset for the sensor. The ALS sensor can be set to either standby mode or active mode. At either of these modes, the I<sup>2</sup>C circuitry is always active. The default mode after power up is standby mode. During standby mode, there is no ALS measurement performed but I<sup>2</sup>C communication is allowed to enable read/write to all the registers.

0x80	ALS_CONTR (default = 0x00)							
	B7	B6	B5	B4	B3	B2	B1	B0
	Reserved			ALS Gain			SW Reset	ALS Mode

Field	Bits	Default	Type	Description	
Reserved	7:5	000	RW	000	MUST write to 000 (default)
ALS Gain	4:2	000	RW	000	Gain 1X → 1 lux to 64k lux (default)
				001	Gain 2X → 0.5 lux to 32k lux
				010	Gain 4X → 0.25 lux to 16k lux
				011	Gain 8X → 0.125 lux to 8k lux
				100	Reserved
				101	
				110	Gain 48X → 0.02 lux to 1.3k lux
111	Gain 96X → 0.01 lux to 600 lux				
SW reset	1	0	RW	0	Initial start-up procedure is NOT started (default)
				1	Initial start-up procedure is started, bit has default value of 0 after start-up
ALS mode	0	0	RW	0	Stand-by mode (default)
				1	Active mode



## ALS\_MEAS\_RATE Register (0x85)

The ALS\_MEAS\_RATE register controls the integration time and timing of the periodic measurement of the ALS in active mode. ALS Measurement Repeat Rate is the interval between ALS\_DATA registers update. ALS Integration Time is the measurement time for each ALS cycle.

ALS Measurement Repeat Rate must be set to be equal or larger than the ALS Integration Time. If ALS Measurement Repeat Rate is set to be smaller than ALS Integration Time, it will automatically be reset to be equal to ALS Integration Time by the IC internally.

0x85	ALS_MEAS_RATE (default = 0x03)							
	B7	B6	B5	B4	B3	B2	B1	B0
	<i>Reserved</i>		<i>ALS Integration Time</i>			<i>ALS Measurement Repeat Rate</i>		

Field	Bits	Default	Type	Description	
Reserved	7:6	00	-	--	--
ALS integration time	5:3	000	RW	000	100ms (default)
				001	50ms
				010	200ms
				011	400ms
				100	150ms
				101	250ms
				110	300ms
				111	350ms
ALS measurement rate	2:0	011	RW	000	50ms
				001	100ms
				010	200ms
				011	500ms (default)
				100	1000ms
				101	2000ms
				110	
				111	

## PART\_ID Register (0x86) (Read Only)

The PART\_ID register defines the part number and revision identification of the sensor.

<b>0x86</b>	<b>PART_ID (default = 0xA0)</b>							
	<b>B7</b>	<b>B6</b>	<b>B5</b>	<b>B4</b>	<b>B3</b>	<b>B2</b>	<b>B1</b>	<b>B0</b>
	<i>Part Number ID</i>				<i>Revision ID</i>			

Function	Bits	Default	Type	Description	
Part Number ID	7:4	1010	R	1010	Part ID 0x0AH
Revision ID	3:0	0000	R	0000	Revision ID 0x00H

## MANUFAC\_ID Register (0x87) (Read Only)

The MANUFAC\_ID register defines the manufacturer identification of the sensor.

<b>0x87</b>	<b>MANUFAC_ID (default = 0x05)</b>							
	<b>B7</b>	<b>B6</b>	<b>B5</b>	<b>B4</b>	<b>B3</b>	<b>B2</b>	<b>B1</b>	<b>B0</b>
	<i>Manufacturer ID</i>							

Field	Bits	Default	Type	Description	
Manufacturer ID	7:0	00000101	R	NA	Manufacturer ID 0x05

## ALS\_DATA\_CH1 Register (0x88 / 0x89) (Read Only)

The ALS\_DATA registers should be read as a group, with the lower address read back first (i.e. read 0x88 first, then read 0x89). These two registers should also be read before reading channel-0 data (from registers 0x8A, 0x8B).

When the I<sup>2</sup>C read operation starts, all four ALS data registers are locked until the I<sup>2</sup>C read operation of register 0x8B is completed. This will ensure that the data in the registers is from the same measurement even if an additional integration cycle ends during the read operation. New measurement data is stored into temporary registers and the ALS\_DATA registers are updated as soon as there is no on-going I<sup>2</sup>C read operation.

The ALS ADC channel-1 data is expressed as a 16-bit data spread over two registers. The ALS\_DATA\_CH1\_0 and ALS\_DATA\_CH1\_1 registers provide the lower and upper byte respectively.

<b>0x88</b>	<b>ALS_DATA_CH1_0 (default = 0x00)</b>							
	<b>B7</b>	<b>B6</b>	<b>B5</b>	<b>B4</b>	<b>B3</b>	<b>B2</b>	<b>B1</b>	<b>B0</b>
	<i>ALS Data Ch1 Low</i>							

<b>0x89</b>	<b>ALS_DATA_CH1_1 (default = 0x00)</b>							
	<b>B7</b>	<b>B6</b>	<b>B5</b>	<b>B4</b>	<b>B3</b>	<b>B2</b>	<b>B1</b>	<b>B0</b>
	<i>ALS Data Ch1 High</i>							

Field	Addr	Bits	Default	Type	Description
ALS Data Ch1 Low	0x88	7:0	00000000	R	ALS ADC channel 1 lower byte data
ALS Data Ch1 High	0x89	7:0	00000000	R	ALS ADC channel 1 upper byte data

## ALS\_DATA\_CH0 Register (0x8A / 0x8B) (Read Only)

These two registers should be read after reading channel-1 data (from registers 0x88, 0x89). Lower address register should be read first (i.e read 0x8A first, then read 0x8B). See ALS\_DATA\_CH1 register information above.

The ALS ADC channel-0 data is expressed as a 16-bit data spread over two registers. The ALS\_DATA\_CH0\_0 and ALS\_DATA\_CH0\_1 registers provide the lower and upper byte respectively.

<b>0x8A</b>	<b>ALS_DATA_CH0_0 (default = 0x00)</b>							
	<b>B7</b>	<b>B6</b>	<b>B5</b>	<b>B4</b>	<b>B3</b>	<b>B2</b>	<b>B1</b>	<b>B0</b>
	<i>ALS Data Ch0 Low</i>							

<b>0x8B</b>	<b>ALS_DATA_CH0_1 (default = 0x00)</b>							
	<b>B7</b>	<b>B6</b>	<b>B5</b>	<b>B4</b>	<b>B3</b>	<b>B2</b>	<b>B1</b>	<b>B0</b>
	<i>ALS Data Ch0 High</i>							

Field	Addr	Bits	Default	Type	Description
ALS Data Ch0 Low	0x8A	7:0	00000000	R	ALS ADC channel 0 lower byte data
ALS Data Ch0 High	0x8B	7:0	00000000	R	ALS ADC channel 0 upper byte data

## ALS\_STATUS Register (0x8C) (Read Only)

The ALS\_STATUS register stores the information about interrupt status and ALS data status. New data means data has not been read yet. When the measurement is completed and data is written to the data register, the data status bit will be set to logic 1. When the data register is read, the data status bit will be set to logic 0.

Interrupt status determines if the ALS interrupt criteria are met. It will check if the ALS measurement data is outside of the range defined by the upper and lower threshold limits.

0x8C	ALS_STATUS (default = 0x00)							
	B7	B6	B5	B4	B3	B2	B1	B0
	ALS Data Valid	ALS Gain			ALS Interrupt Status	ALS Data Status	Reserved	

Field	Bits	Default	Type	Description	
ALS Data Valid	7	0	R	0	ALS Data is Valid (default)
				1	ALS Data is Invalid
ALS Data Gain Range	6:4	000	R	000	ALS measured data in Gain 1X (default)
				001	ALS measured data in Gain 2X
				010	ALS measured data in Gain 4X
				011	ALS measured data in Gain 8X
				100	Invalid
				101	Invalid
				110	ALS measured data in Gain 48X
				111	ALS measured data in Gain 96X
ALS interrupt status	3	0	R	0	interrupt signal INACTIVE (default)
				1	interrupt signal ACTIVE
ALS data status	2	0	R	0	OLD data (data already read), (default)
				1	NEW data (first time data is read)
Reserved	1:0	00	R	--	Don't care

## INTERRUPT Register (0x8F)

The INTERRUPT register controls the operation of the interrupt pin and functions. When the Interrupt Mode is set to 00, the INT output pin 2 is inactive / disabled and will not trigger any interrupt.

Note that when this register is to be set with values other than its default values, it should be set before device is in Active mode.

0x8F	INTERRUPT (default = 0x08)								
	B7	B6	B5	B4	B3	B2	B1	B0	
	<i>Reserved</i>					<i>Interrupt Polarity</i>	<i>Interrupt Mode</i>	<i>Reserved</i>	

Field	Bits	Default	Type	Description	
RESERVED	7:3	00001	--	-- Must write as 00000 Bit B3 is "1" (default) but it has no impact on performance	
Interrupt Polarity	2	0	RW	0	INT pin is considered active when it is a logic 0 (default)
				1	INT pin is considered active when it is a logic 1
Interrupt mode	1	0	RW	0	Interrupt pin is INACTIVE / high impedance state (default)
				1	ALS measurement can trigger interrupt
RESERVED	0	0	--	-- Don't care	

## ALS\_THRES Register (0x97 / 0x98 / 0x99 / 0x9A)

The ALS\_THRES\_UP and ALS\_THRES\_LOW registers determines the upper and lower limit of the interrupt threshold value respectively. These two values form a range and the interrupt function compares if the measurement value in ALS\_DATA registers is inside or outside the range. The interrupt function is active if the measurement data is outside the range defined by the upper and lower limits. The data format for ALS\_THRES must be the same as ALS\_DATA registers.

<b>0x97</b>	<b>ALS_THRES_UP_0 (default = 0xFF)</b>							
	<b>B7</b>	<b>B6</b>	<b>B5</b>	<b>B4</b>	<b>B3</b>	<b>B2</b>	<b>B1</b>	<b>B0</b>
	<i>ALS Upper Threshold Low</i>							

<b>0x98</b>	<b>ALS_THRES_UP_1 (default = 0xFF)</b>							
	<b>B7</b>	<b>B6</b>	<b>B5</b>	<b>B4</b>	<b>B3</b>	<b>B2</b>	<b>B1</b>	<b>B0</b>
	<i>ALS Upper Threshold High</i>							

<b>0x99</b>	<b>ALS_THRES_LOW_0 (default = 0x00)</b>							
	<b>B7</b>	<b>B6</b>	<b>B5</b>	<b>B4</b>	<b>B3</b>	<b>B2</b>	<b>B1</b>	<b>B0</b>
	<i>ALS Lower Threshold Low</i>							

<b>0x9A</b>	<b>ALS_THRES_LOW_1 (default = 0x00)</b>							
	<b>B7</b>	<b>B6</b>	<b>B5</b>	<b>B4</b>	<b>B3</b>	<b>B2</b>	<b>B1</b>	<b>B0</b>
	<i>ALS Lower Threshold High</i>							

Field	Addr	Bits	Default	Type	Description	
ALS upper threshold Low	0x97	7:0	11111111	RW	--	ALS upper threshold lower byte
ALS upper threshold High	0x98	7:0	11111111	RW	--	ALS upper threshold upper byte
ALS lower threshold Low	0x99	7:0	00000000	RW	--	ALS lower threshold lower byte
ALS lower threshold High	0x9A	7:0	00000000	RW	--	ALS lower threshold upper byte

### INTERRUPT PERSIST Register (0x9E)

The INTERRUPT PERSIST register controls the N number of times the measurement data is outside the range defined by the upper and lower threshold limits before asserting the INT output pin 2.

0x9E	INTERRUPT PERSIST (default = 0x00)							
	B7	B6	B5	B4	B3	B2	B1	B0
	<i>Reserved</i>				<i>ALS Persist</i>			

Field	Bits	Default	Type	Description	
Reserved	7:4	0000	RW	Don't care	
ALS persist	3:0	0000	RW	0000	Every ALS value out of threshold range (default)
				0001	2 consecutive ALS values out of threshold range
				....	....
				1111	16 consecutive ALS values out of threshold range



## 6. Device Operation (using Interrupt)

Below flow diagram illustrates the LTR-303ALS operation involving the use of Thresholds and Interrupts.

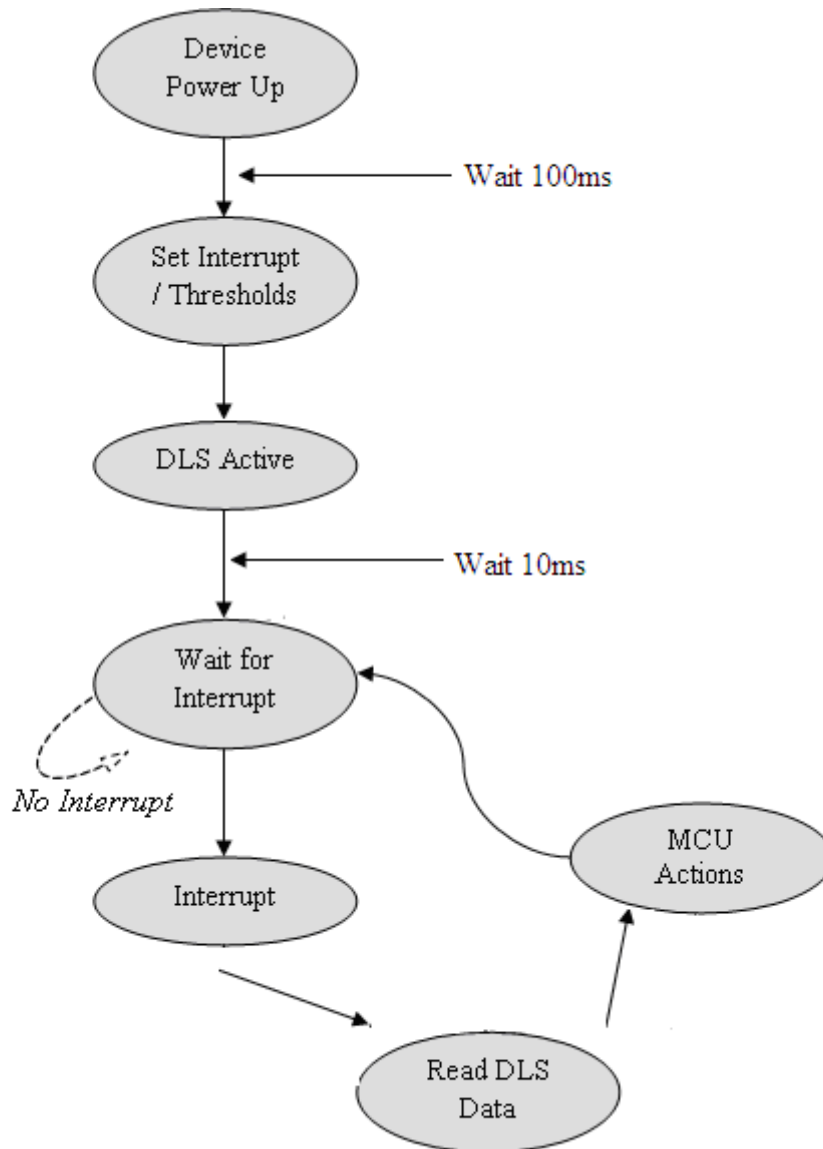

## 7. Device Operation (without using Interrupt)

Below flow diagram illustrates the LTR-303ALS operation without the use of interrupts.

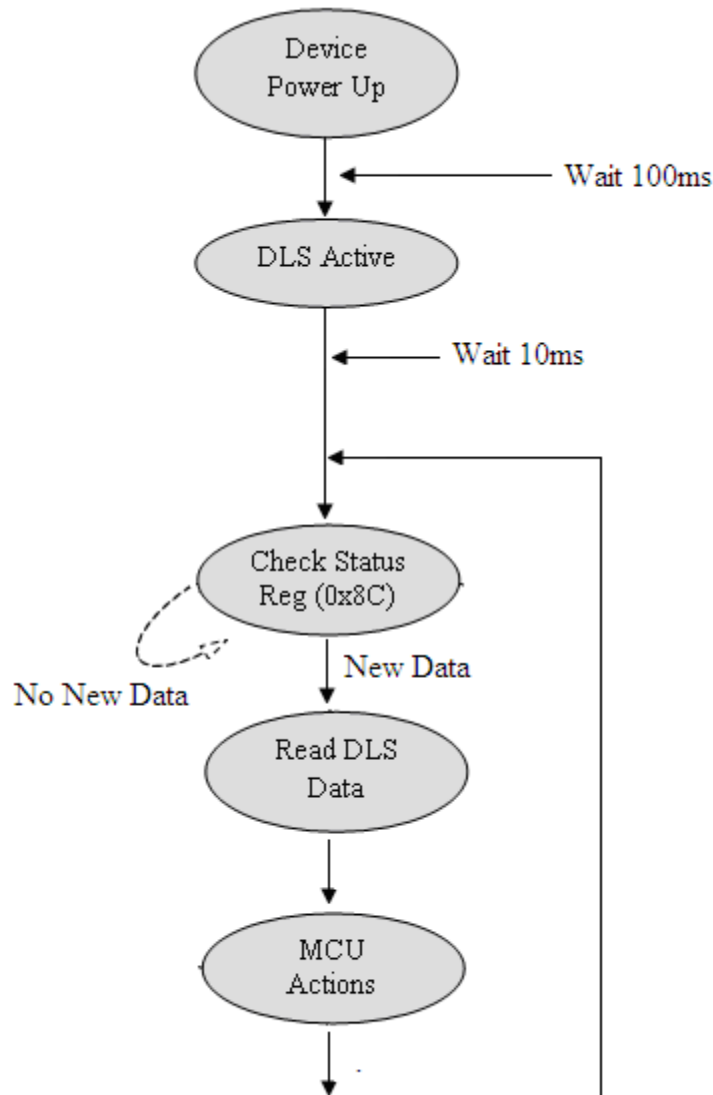

## 8. Pseudo Codes Examples

### Control Registers

// The Control Register defines the operating modes and gain settings of the ALS of LTR-303.  
// Default settings is 0x00 (in Standby mode).

Slave\_Addr = 0x29 // Slave address of LTR-303 device

#### // Enable ALS

Register\_Addr = 0x80 // ALS\_CONTR register  
Command = 0x01 // For Gain X1  
// For Gain X96, Command = 0x1D

WriteByte(Slave\_Addr, Register\_Addr, Command)

### ALS Measurement Rate

// The ALS\_MEAS\_RATE register controls the ALS integration time and measurement rate.  
// Default setting of the register is 0x03 (integration time 100ms, repeat rate 500ms)

Slave\_Addr = 0x29 // Slave address of LTR-303 device

#### // Set ALS Integration Time 200ms, Repeat Rate 200ms

Register\_Addr = 0x85 // ALS\_MEAS\_RATE register  
Command = 0x12 // Int time = 200ms, Meas rate = 200ms  
// For Int time = 400ms, Meas rate = 500ms, Command = 0x1B

WriteByte(Slave\_Addr, Register\_Addr, Command)

### ALS Data Registers (Read Only)

// The ALS Data Registers contain the ADC output data for the respective channel.  
// These registers should be read as a group, with the lower address being read first.

Slave\_Addr = 0x29 // Slave address of LTR-303 device

#### // Read back ALS\_DATA\_CH1

Register\_Addr = 0x88 // ALS\_DATA\_CH1 low byte address  
ReadByte(Slave\_Addr, Register\_Addr, Data0)  
Register\_Addr = 0x89 // ALS\_DATA\_CH1 high byte address  
ReadByte(Slave\_Addr, Register\_Addr, Data1)

#### // Read back ALS\_DATA\_CH0

Register\_Addr = 0x8A // ALS\_DATA\_CH0 low byte address  
ReadByte(Slave\_Addr, Register\_Addr, Data2)  
Register\_Addr = 0x8B // ALS\_DATA\_CH0 high byte address  
ReadByte(Slave\_Addr, Register\_Addr, Data3)

ALS\_CH1\_ADC\_Data = (Data1 << 8) | Data0 // Combining lower and upper bytes to give 16-bit Ch1 data

ALS\_CH0\_ADC\_Data = (Data3 << 8) | Data2 // Combining lower and upper bytes to give 16-bit Ch0 data

## ALS Status Register (Read only)

// The ALS\_STATUS Register contains the information on Interrupt, ALS data availability status.  
// This register is read only.

Slave\_Addr = 0x29 // Slave address of LTR-303 device

### // Read back Register

Register\_Addr = 0x8C // ALS\_STATUS register address

ReadByte(Slave\_Addr, Register\_Addr, Data)

Interrupt\_Status = Data & 0x08 // Interrupt\_Status = 8(decimal) → ALS Interrupt

NewData\_Status = Data & 0x04 // NewData\_Status = 4(decimal) → ALS New Data

ALS\_Data\_Valid = Data & 0x80 // ALS\_Data\_Valid = 0x00 → ALS New Data is valid (usable)  
// ALS\_Data\_Valid = 0x80 → ALS New Data is invalid, discard and wait for new ALS data

## Interrupt Registers

// The Interrupt register controls the operation of the interrupt pins and function.

// The default value for this register is 0x08 (Interrupt inactive)

// Note that when this register is to be set with values other than its default values, it should be set before device is in active mode.

Slave\_Addr = 0x29 // Slave address of LTR-303 device

### // Set Interrupt Polarity for ALS Active Low trigger

Register\_Addr = 0x8F // Interrupt Register address

Command = 0x0A // Interrupt is Active Low ALS trigger

// For Active High Interrupt ALS trigger, Command = 0x0E

WriteByte(Slave\_Addr, Register\_Addr, Command)

## ALS Threshold Registers

// The ALS\_THRES\_UP and ALS\_THRES\_LOW registers determines the upper and lower limit of the interrupt threshold value.  
// Following example illustrates the setting of the ALS threshold window of decimal values of 200 (lower threshold) and 1000 (upper threshold)

Slave\_Addr = 0x29 // Slave address of LTR-303 device

### // Upper Threshold Setting (decimal 1000)

ALS\_Upp\_Threshold\_Reg\_0 = 0x97 // ALS Upper Threshold Low Byte Register address  
ALS\_Upp\_Threshold\_Reg\_1 = 0x98 // ALS Upper Threshold High Byte Register address  
Data1 = 1000 >> 8 // To convert decimal 1000 into two eight bytes register values  
Data0 = 1000 & 0xFF  
WriteByte(Slave\_Addr, ALS\_Upp\_Threshold\_Reg\_0, Data0)  
WriteByte(Slave\_Addr, ALS\_Upp\_Threshold\_Reg\_1, Data1)

### // Lower Threshold Setting (decimal 200)

ALS\_Low\_Threshold\_Reg\_0 = 0x99 // ALS Lower Threshold Low Byte Register address  
ALS\_Low\_Threshold\_Reg\_1 = 0x9A // ALS Lower Threshold High Byte Register address  
Data1 = 200 >> 8 // To convert decimal 200 into two eight bytes register values  
Data0 = 200 & 0xFF  
WriteByte(Slave\_Addr, ALS\_Low\_Threshold\_Reg\_0, Data0)  
WriteByte(Slave\_Addr, ALS\_Low\_Threshold\_Reg\_1, Data1)

## 9. Recommended Lead-free Reflow Profile

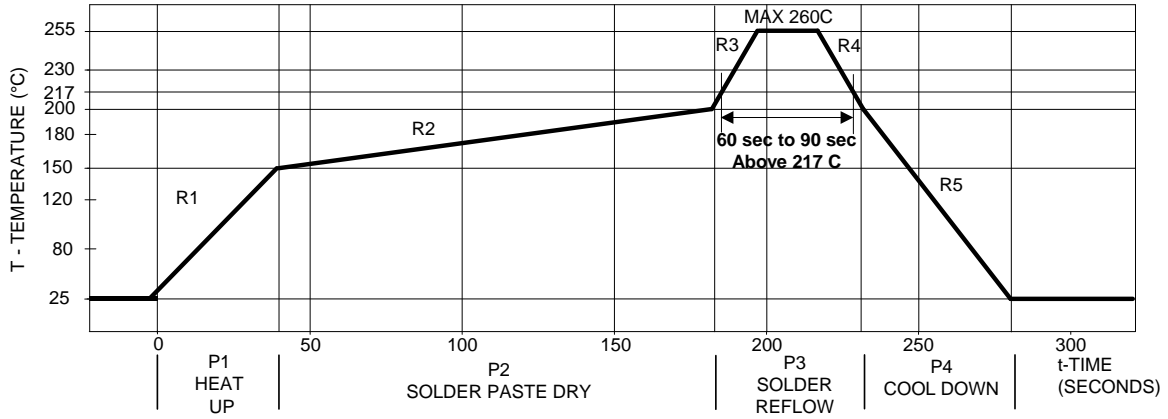

Process Zone	Symbol	$\Delta T$	Maximum $\Delta T/\Delta$ time or Duration
Heat Up	P1, R1	25°C to 150°C	3°C/s
Solder Paste Dry	P2, R2	150°C to 200°C	100s to 180s
Solder Reflow	P3, R3	200°C to 260°C	3°C/s
	P3, R4	260°C to 200°C	-6°C/s
Cool Down	P4, R5	200°C to 25°C	-6°C/s
Time maintained above liquidus point , 217°C		> 217°C	60s to 90s
Peak Temperature		260°C	-
Time within 5°C of actual Peak Temperature		> 255°C	20s
Time 25°C to Peak Temperature		25°C to 260°C	8mins

It is recommended to perform reflow soldering no more than twice.

## 10. Moisture Proof Packaging

All LTR-303ALS-01 are shipped in moisture proof package. Once opened, moisture absorption begins.

This part is compliant to JEDEC J-STD-033A Level 3.

### Time from Unsealing to Soldering

After removal from the moisture barrier bag, the parts should be stored at the recommended storage conditions and soldered within seven days. When the moisture barrier bag is opened and the parts are exposed to the recommended storage conditions for more than seven days, the parts must be baked before reflow to prevent damage to the parts.

### Recommended Storage Conditions

<b>Storage Temperature</b>	10°C to 30°C
<b>Relative Humidity</b>	Below 60% RH

### Baking Conditions

Package	Temperature	Time
In Reels	60°C	48 hours
In Bulk	100°C	4 hours

Baking should only be done once.

## 11. Recommended Land Pattern and Metal Stencil Aperture

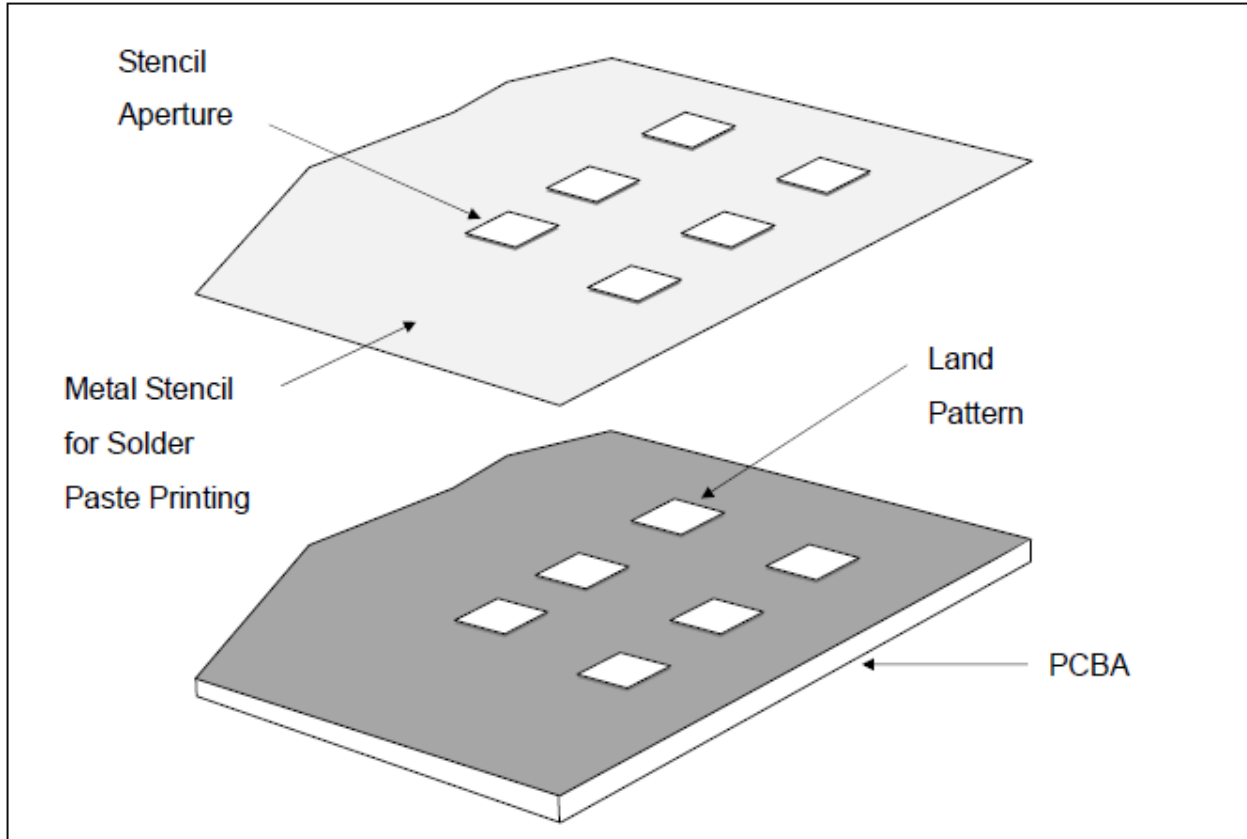

### Recommended Land Pattern

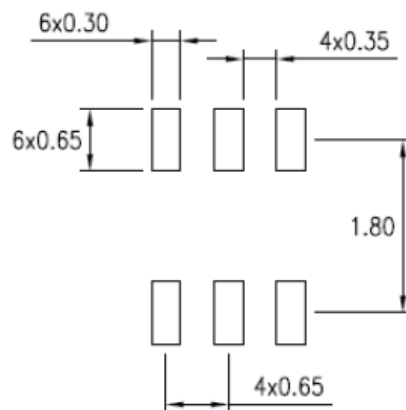

Note: All dimensions are in millimeters



## Recommended Metal Stencil Aperture

It is recommended that the metal stencil used for solder paste printing has a thickness (t) of 0.11mm (0.004 inches / 4 mils) or 0.127mm (0.005 inches / 5 mils).

The stencil aperture opening is recommended to be 0.3mm x 0.65mm which has the same dimension as the land pattern. This is to ensure adequate printed solder paste volume and yet no shorting.

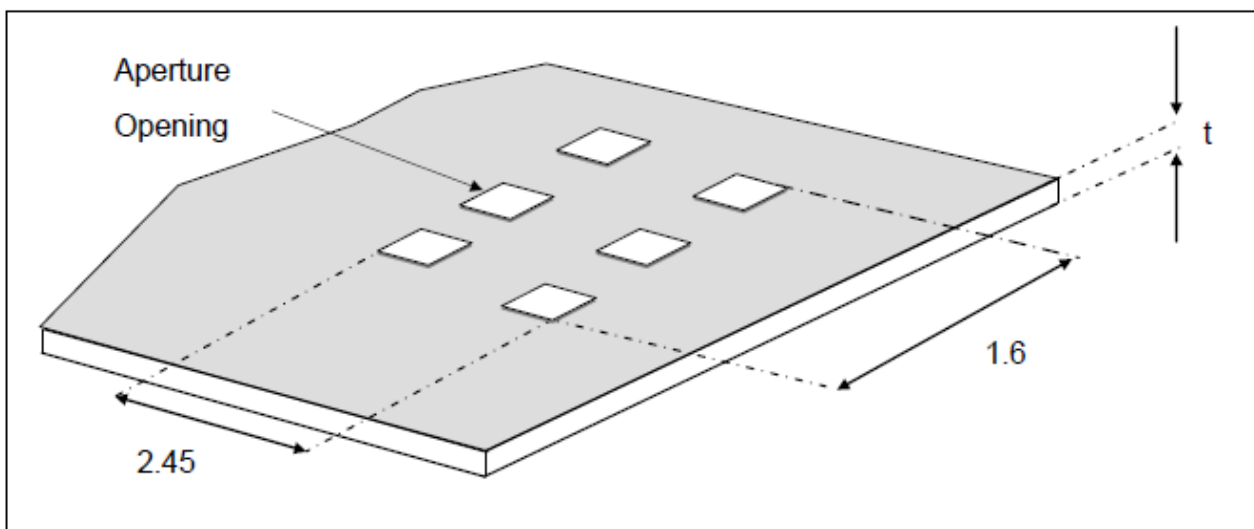

**Note:**

1. All dimensions are in millimeters

## 12. Package Dimension for Tape and Reel

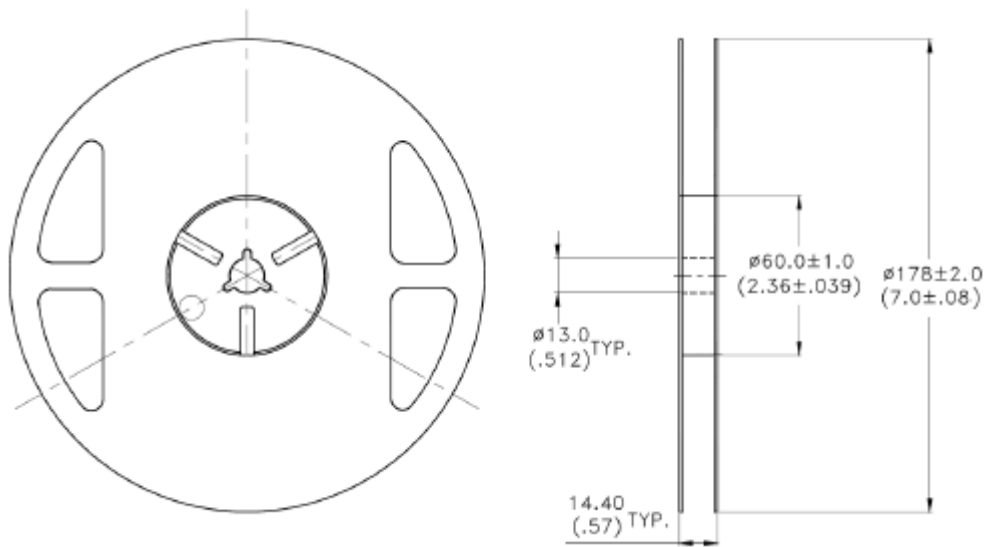
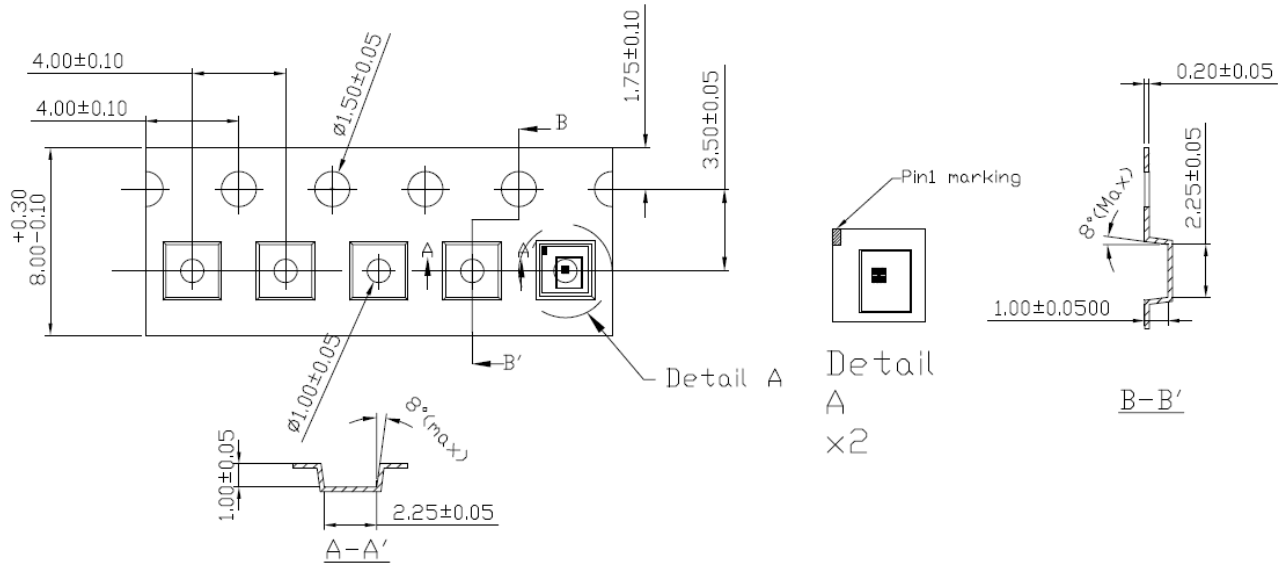

**Notes:**

1. All dimensions are in millimeters (inches)
2. Empty component pockets sealed with top cover tape
3. 7 inch reel - 2500 pieces per reel
4. In accordance with ANSI/EIA 481-1-A-1994 specifications

Компания «Life Electronics» занимается поставками электронных компонентов импортного и отечественного производства от производителей и со складов крупных дистрибьюторов Европы, Америки и Азии.

С конца 2013 года компания активно расширяет линейку поставок компонентов по направлению коаксиальный кабель, кварцевые генераторы и конденсаторы (керамические, пленочные, электролитические), за счёт заключения дистрибьюторских договоров

Мы предлагаем:

- Конкурентоспособные цены и скидки постоянным клиентам.
- Специальные условия для постоянных клиентов.
- Подбор аналогов.
- Поставку компонентов в любых объемах, удовлетворяющих вашим потребностям.
- Приемлемые сроки поставки, возможна ускоренная поставка.
- Доставку товара в любую точку России и стран СНГ.
- Комплексную поставку.
- Работу по проектам и поставку образцов.
- Формирование склада под заказчика.
- Сертификаты соответствия на поставляемую продукцию (по желанию клиента).
- Тестирование поставляемой продукции.
- Поставку компонентов, требующих военную и космическую приемку.
- Входной контроль качества.
- Наличие сертификата ISO.

В составе нашей компании организован Конструкторский отдел, призванный помогать разработчикам, и инженерам.

Конструкторский отдел помогает осуществить:

- Регистрацию проекта у производителя компонентов.
- Техническую поддержку проекта.
- Защиту от снятия компонента с производства.
- Оценку стоимости проекта по компонентам.
- Изготовление тестовой платы монтаж и пусконаладочные работы.



Тел: +7 (812) 336 43 04 (многоканальный)

Email: [org@lifeelectronics.ru](mailto:org@lifeelectronics.ru)