

# MPX53, 0 to 50 kPa, Differential and Gauge, Uncompensated, Silicon Pressure Sensors

The MPX53 series silicon piezoresistive pressure sensors provide a very accurate and linear voltage output, directly proportional to the applied pressure. These standard, uncompensated sensors permit manufacturers to design and add their own external temperature compensating and signal conditioning networks. Compensation techniques are simplified because of the predictability of Freescale's single element strain gauge design.

### Features

- Patented silicon shear stress strain gauge design
- Ratiometric to supply voltage
- Easy to use chip carrier package options
- 60 mV span (typical)
- Differential and gauge options

### Typical applications

- Air movement control
- Environmental control systems
- Level indicators
- Leak detection
- Medical instrumentation
- Industrial controls
- Pneumatic control systems
- Robotics

## MPX53

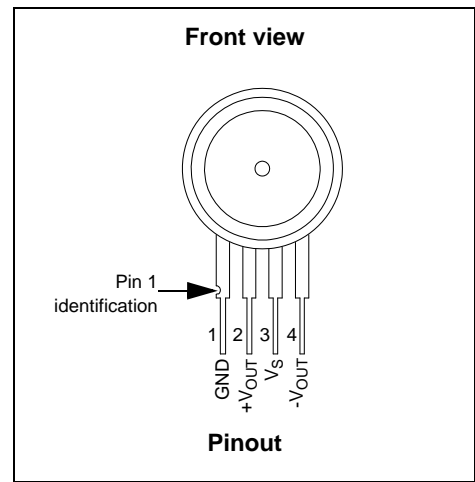
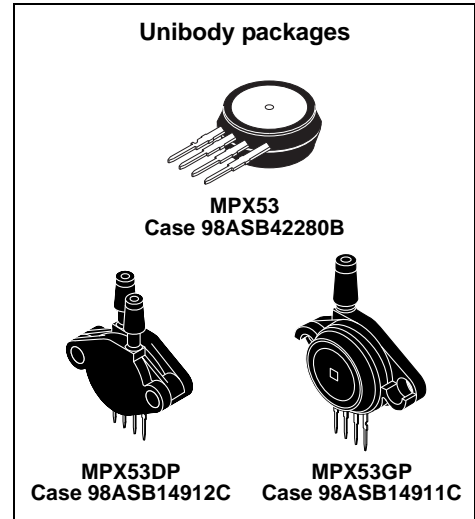

Ordering information									
Device name	Shipping	Package	# of Ports			Pressure type			Device marking
			None	Single	Dual	Gauge	Differential	Absolute	
<b>Unibody package</b>									
MPX53D	Rail	98ASB42280B	•				•		MPX53D
MPX53DP	Rail	98ASB14912C			•		•		MPX53DP
MPX53GP	Rail	98ASB14911C		•		•			MPX53GP

Freescale reserves the right to change the detail specifications as may be required to permit improvements in the design of its products.

© 2007-2009, 2015 Freescale Semiconductor, Inc. All rights reserved.



## Contents

<b>1</b>	<b>General Description</b> .....	<b>3</b>
1.1	Block diagram .....	3
1.2	Pinout .....	3
<b>2</b>	<b>Mechanical and Electrical Specifications</b> .....	<b>4</b>
2.1	Maximum ratings .....	4
2.2	Operating characteristics .....	4
2.3	Voltage output versus applied differential pressure .....	5
2.4	Temperature compensation .....	5
2.5	Linearity .....	5
<b>3</b>	<b>Package Information</b> .....	<b>7</b>
3.1	Pressure (P1)/Vacuum (P2) side identification .....	7
3.2	Package dimensions .....	8
<b>4</b>	<b>Revision History</b> .....	<b>11</b>

## Related Documentation

The MPX53 device features and operations are described in a variety of reference manuals, user guides, and application notes. To find the most-current versions of these documents:

1. Go to the Freescale homepage at:  
<http://www.freescale.com/>
2. In the Keyword search box at the top of the page, enter the device number MPX53.
3. In the Refine Your Result pane on the left, click on the Documentation link.

### MPX53

# 1 General Description

## 1.1 Block diagram

Figure 1 shows a schematic of the internal circuitry on the stand-alone pressure sensor chip.

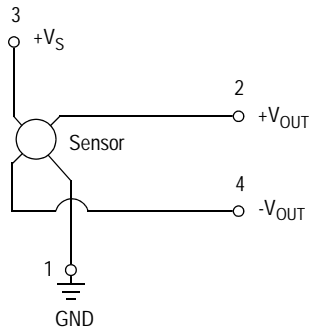

Figure 1. Uncompensated pressure sensor schematic

## 1.2 Pinout

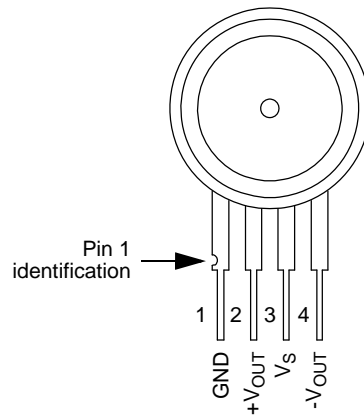

Figure 2. Device pinout (front view)

Table 1. Pin functions

Pin	Name	Function
1	GND	Ground, denoted by notch.
2	+V <sub>OUT</sub>	Output voltage
3	V <sub>S</sub>	Voltage supply
4	-V <sub>OUT</sub>	Output voltage

## 2 Mechanical and Electrical Specifications

### 2.1 Maximum ratings

**Table 2. Maximum ratings<sup>(1)</sup>**

Rating	Symbol	Value	Unit
Maximum Pressure (P1 > P2)	P <sub>MAX</sub>	175	kPa
Burst Pressure (P1 > P2)	P <sub>Burst</sub>	200	kPa
Storage Temperature	T <sub>STG</sub>	-40 to +125	°C
Operating Temperature	T <sub>A</sub>	-40 to +125	°C

1. Exposure beyond the specified limits may cause permanent damage or degradation to the device.

### 2.2 Operating characteristics

**Table 3. Operating characteristics** (V<sub>S</sub> = 3.0 Vdc, T<sub>A</sub> = 25 °C unless otherwise noted, P1 > P2)

Characteristic	Symbol	Min	Typ	Max	Units
Pressure range <sup>(1)</sup>	P <sub>OP</sub>	0	—	50	kPa
Supply voltage <sup>(2)</sup>	V <sub>S</sub>	—	3.0	6.0	V <sub>DC</sub>
Supply current	I <sub>O</sub>	—	6.0	—	mAdc
Full-scale span <sup>(3)</sup>	V <sub>FSS</sub>	45	60	90	mV
Offset <sup>(4)</sup>	V <sub>OFF</sub>	0	20	35	mV
Sensitivity	ΔV/ΔP	—	1.2	—	mV/kPa
Linearity	—	-0.6	—	0.4	%V <sub>FSS</sub>
Pressure hysteresis (0 to 50 kPa)	—	—	±0.1	—	%V <sub>FSS</sub>
Temperature hysteresis	—	—	±0.5	—	%V <sub>FSS</sub>
Temperature coefficient of full-scale span	TCV <sub>FSS</sub>	-0.22	—	-0.16	%V <sub>FSS</sub> /°C
Temperature coefficient of offset	TCV <sub>OFF</sub>	—	±15	—	μV/°C
Temperature coefficient of resistance	TCR	0.21	—	0.27	%Z <sub>IN</sub> /°C
Input impedance	Z <sub>IN</sub>	355	—	505	Ω
Output impedance	Z <sub>OUT</sub>	750	—	1875	Ω
Response time <sup>(5)</sup> (10% to 90%)	t <sub>R</sub>	—	1.0	—	ms
Warm-up time <sup>(6)</sup>	—	—	20	—	ms
Offset stability <sup>(7)</sup>	—	—	±0.5	—	%V <sub>FSS</sub>

1. 1.0 kPa (kiloPascal) equals 0.145 psi.

2. Device is ratiometric within this specified excitation range. Operating the device above the specified excitation range may induce additional error due to device self-heating.

3. Full-scale span (V<sub>FSS</sub>) is defined as the algebraic difference between the output voltage at full rated pressure and the output voltage at the minimum rated pressure.

4. Offset (V<sub>OFF</sub>) is defined as the output voltage at the minimum rated pressure.

5. Response time is defined as the time for the incremental change in the output to go from 10% to 90% of its final value when subjected to a specified step change in pressure.

6. Warm-up time is defined as the time required for the product to meet the specified output voltage after the pressure is stabilized.

7. Offset stability is the product's output deviation when subjected to 1000 hours of pulsed pressure, temperature cycling with bias test.

## 2.3 Voltage output versus applied differential pressure

The differential voltage output of the sensor is directly proportional to the differential pressure (P1) relative to the vacuum side (P2). Similarly, output voltage increases as increasing vacuum is applied to the vacuum side (P2) relative to the pressure side (P1).

## 2.4 Temperature compensation

Figure 3 shows the typical output characteristics of the MPX53 series over temperature.

The piezoresistive pressure sensor element is a semiconductor device which gives an electrical output signal proportional to the pressure applied to the device. This device uses a unique transverse voltage diffused semiconductor strain gauge which is sensitive to stresses produced in a thin silicon diaphragm by the applied pressure.

Because this strain gauge is an integral part of the silicon diaphragm, there are no temperature effects due to differences in the thermal expansion of the strain gauge and the diaphragm, as are often encountered in bonded strain gauge pressure sensors. However, the properties of the strain gauge itself are temperature dependent, requiring that the device be temperature compensated if it is to be used over an extensive temperature range.

Temperature compensation and offset calibration can be achieved rather simply with additional resistive components, or by designing your system using the MPX2053 series sensors.

Several approaches to external temperature compensation over  $-40$  to  $+125$  °C and  $0$  to  $+80$  °C are presented in Freescale Application Note, AN840.

## 2.5 Linearity

Linearity refers to how well a transducer's output follows the equation:  $V_{OUT} = V_{OFF} + (\text{sensitivity} \times P)$  over the operating pressure range (see Figure 3). There are two basic methods for calculating nonlinearity: (1) end point straight line fit or (2) a least squares best line fit. While a least squares fit gives the "best case" linearity error (lower numerical value), the calculations required are burdensome.

Conversely, an end point fit will give the "worst case" error (often more desirable in error budget calculations) and the calculations are more straightforward for the user. Freescale's specified pressure sensor linearities are based on the end point straight line method measured at the midrange pressure.

Figure 4 illustrates the differential or gauge configuration in the unibody chip carrier (Case 98ASB42280B). A silicone gel isolates the die surface and wire bonds from the environment, while allowing the pressure signal to be transmitted to the silicon diaphragm.

The MPX53 series pressure sensor operating characteristics and internal reliability and qualification tests are based on use of dry air as the pressure media. Media other than dry air may have adverse effects on sensor performance and long term reliability. Refer to application note AN3728, for more information regarding media compatibility.

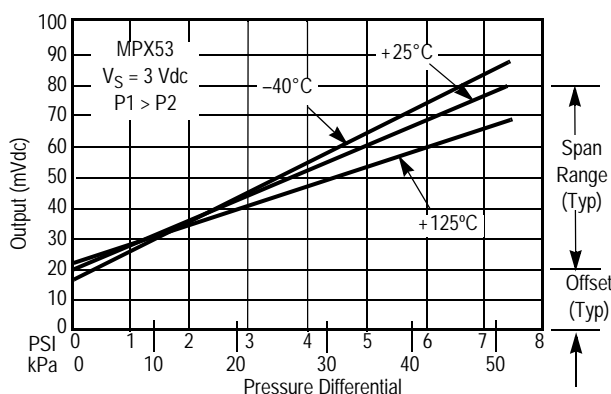

Figure 3. Output vs. pressure differential

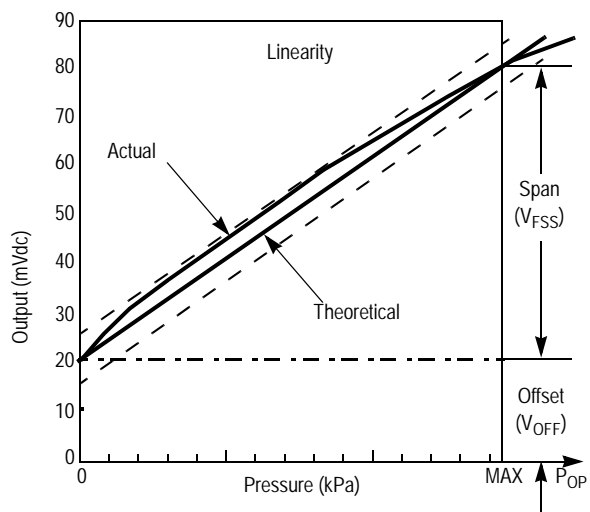

Figure 4. Linearity specification comparison

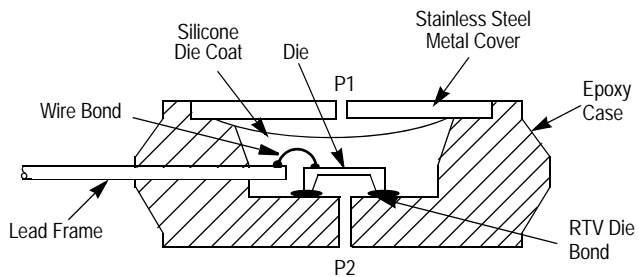

Figure 5. Unibody package — cross-sectional diagram (not to scale)

### 3 Package Information

#### 3.1 Pressure (P1)/Vacuum (P2) side identification

Freescale designates the two sides of the pressure sensor as the Pressure (P1) side and the Vacuum (P2) side. The Pressure (P1) side is the side containing silicone gel which isolates the die from the environment. The Freescale MPX53 pressure sensor is designed to operate with positive differential pressure applied,  $P1 > P2$ .

The Pressure (P1) side may be identified by using the following table.

Part number	Case number	Pressure (P1) side identifier
MPX53D	98ASB42280B	Stainless steep cap
MPX53DP	98ASB14912C	Side with port marking
MPX53GP	98ASB14911C	Side with port attached

### 3.2 Package dimensions

This drawing is located at [http://cache.freescale.com/files/shared/doc/package\\_info/98ASB42280B.pdf](http://cache.freescale.com/files/shared/doc/package_info/98ASB42280B.pdf).

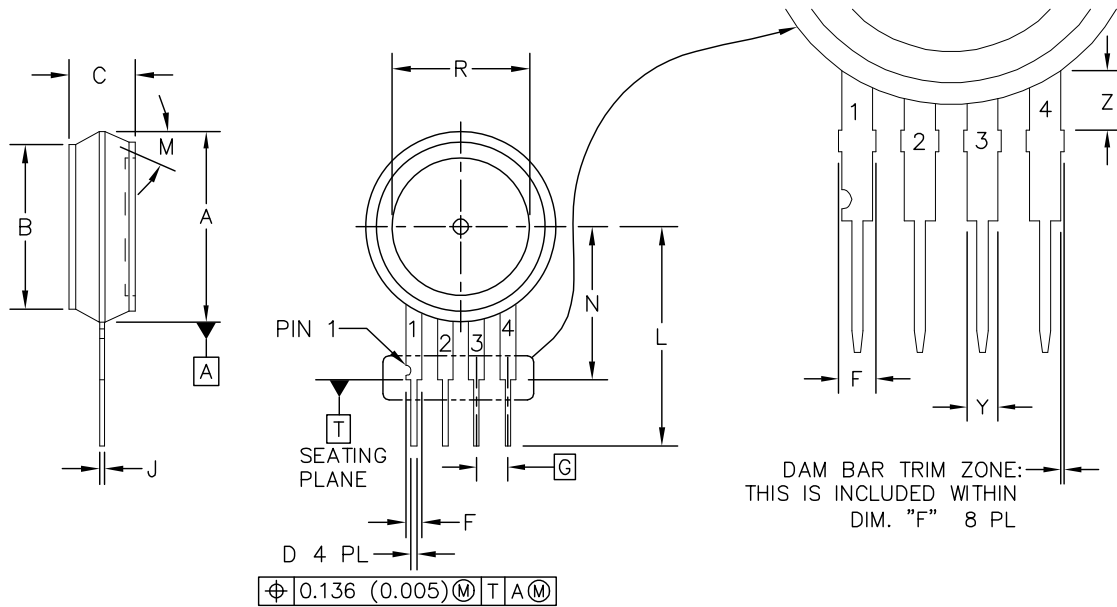

DIM	MILLIMETERS		INCHES	
	MIN	MAX	MIN	MAX
A	15.11	16.00	0.595	0.630
B	13.06	13.56	0.514	0.534
C	5.08	5.59	0.200	0.220
D	0.41	0.51	0.016	0.020
F	1.22	1.63	0.048	0.064
G	2.54	BSC	0.100	BSC
J	0.36	0.40	0.014	0.016
L	17.65	18.42	0.695	0.725
M	30'	NOM	30'	NOM
N	12.07	12.57	0.475	0.495
R	10.92	11.43	0.430	0.450
Y	1.22	1.32	0.048	0.052
Z	2.68	3.00	0.106	0.118

NOTES:

1. DIMENSIONING AND TOLERANCING PER ASME Y14.5M, 1994
2. CONTROLLING DIMENSION: INCH.
3. DIMENSION A IS INCLUSIVE OF THE MOLD STOP RING NOT TO EXCEED 16.00 (0.630)
4. 344-01 THRU -4 OBSOLETE.
5. 344-05 THRU -11 OBSOLETE, NEW STANDARD 344-15.

© FREESCALE SEMICONDUCTOR, INC. ALL RIGHTS RESERVED.		MECHANICAL OUTLINE	PRINT VERSION NOT TO SCALE
TITLE:  UNIBODY A & D		DOCUMENT NO: 98ASB42280B	REV: AC
		STANDARD: NON-JEDEC	
		10 DEC 2012	

Case 98ASB42280B, Unibody package



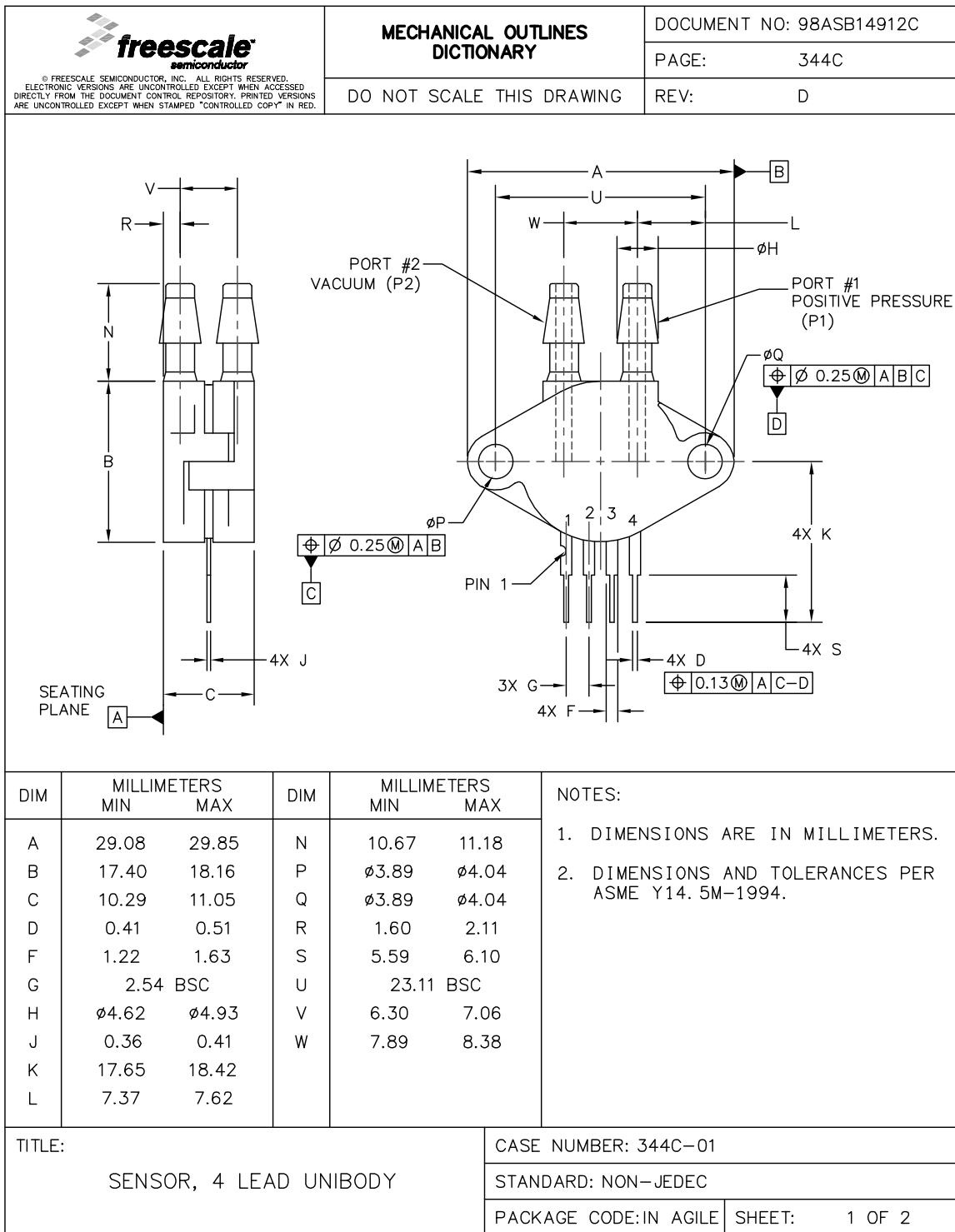

**Case 98ASB14912C, Unibody package**

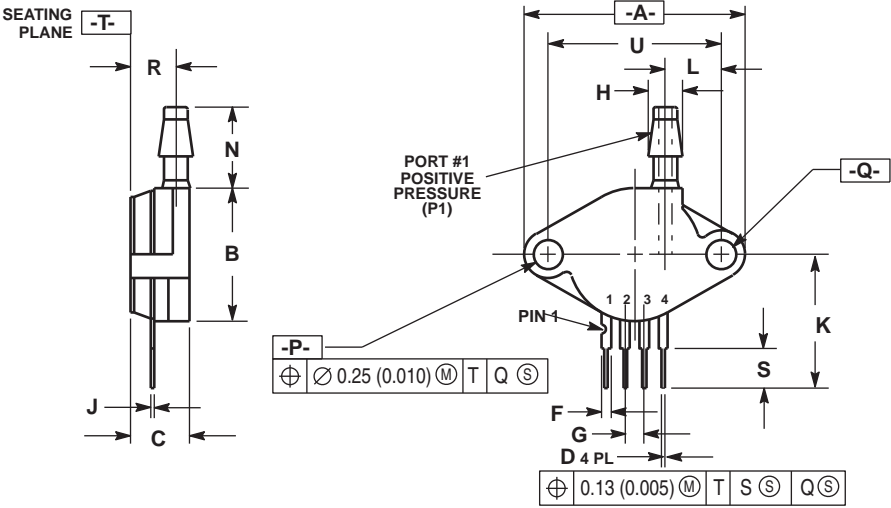

NOTES:  
 1. DIMENSIONING AND TOLERANCING PER ANSI Y14.5M, 1982.  
 2. CONTROLLING DIMENSION: INCH.

DIM	INCHES		MILLIMETERS	
	MIN	MAX	MIN	MAX
A	1.145	1.175	29.08	29.85
B	0.685	0.715	17.40	18.16
C	0.305	0.325	7.75	8.26
D	0.016	0.020	0.41	0.51
F	0.048	0.064	1.22	1.63
G	0.100 BSC		2.54 BSC	
H	0.182	0.194	4.62	4.93
J	0.014	0.016	0.36	0.41
K	0.695	0.725	17.65	18.42
L	0.290	0.300	7.37	7.62
N	0.420	0.440	10.67	11.18
P	0.153	0.159	3.89	4.04
Q	0.153	0.159	3.89	4.04
R	0.230	0.250	5.84	6.35
S	0.220	0.240	5.59	6.10
U	0.910 BSC		23.11 BSC	

Case 98ASB14911C, Unibody package

## 4 Revision History

Table 4. Revision history

Revision number	Revision date	Description
7.1	06/2015	<ul style="list-style-type: none"><li>• Updated format.</li><li>• Removed obsolete MPXV53GC7U option and package drawing.</li><li>• Updated package outline drawings with current versions.</li></ul>



**How to Reach Us:**

**Home Page:**

freescale.com

**Web Support:**

freescale.com/support

Information in this document is provided solely to enable system and software implementers to use Freescale products. There are no express or implied copyright licenses granted hereunder to design or fabricate any integrated circuits based on the information in this document.

Freescale reserves the right to make changes without further notice to any products herein. Freescale makes no warranty, representation, or guarantee regarding the suitability of its products for any particular purpose, nor does Freescale assume any liability arising out of the application or use of any product or circuit, and specifically disclaims any and all liability, including without limitation consequential or incidental damages. "Typical" parameters that may be provided in Freescale data sheets and/or specifications can and do vary in different applications, and actual performance may vary over time. All operating parameters, including "typicals," must be validated for each customer application by customer's technical experts. Freescale does not convey any license under its patent rights nor the rights of others. Freescale sells products pursuant to standard terms and conditions of sale, which can be found at the following address: [freescale.com/salestermsandconditions](http://freescale.com/salestermsandconditions).

Freescale and the Freescale logos are trademarks of Freescale Semiconductor, Inc., Reg. U.S. Pat. & Tm. Off. All other product or service names are the property of their respective owners.

© 2007-2009, 2015 Freescale Semiconductor, Inc.

Document Number: MPX53

Rev. 7.1

07/2015



Компания «Life Electronics» занимается поставками электронных компонентов импортного и отечественного производства от производителей и со складов крупных дистрибьюторов Европы, Америки и Азии.

С конца 2013 года компания активно расширяет линейку поставок компонентов по направлению коаксиальный кабель, кварцевые генераторы и конденсаторы (керамические, пленочные, электролитические), за счёт заключения дистрибьюторских договоров

Мы предлагаем:

- Конкуренспособные цены и скидки постоянным клиентам.
- Специальные условия для постоянных клиентов.
- Подбор аналогов.
- Поставку компонентов в любых объемах, удовлетворяющих вашим потребностям.
- Приемлемые сроки поставки, возможна ускоренная поставка.
- Доставку товара в любую точку России и стран СНГ.
- Комплексную поставку.
- Работу по проектам и поставку образцов.
- Формирование склада под заказчика.
- Сертификаты соответствия на поставляемую продукцию (по желанию клиента).
- Тестирование поставляемой продукции.
- Поставку компонентов, требующих военную и космическую приемку.
- Входной контроль качества.
- Наличие сертификата ISO.

В составе нашей компании организован Конструкторский отдел, призванный помогать разработчикам, и инженерам.

Конструкторский отдел помогает осуществить:

- Регистрацию проекта у производителя компонентов.
- Техническую поддержку проекта.
- Защиту от снятия компонента с производства.
- Оценку стоимости проекта по компонентам.
- Изготовление тестовой платы монтаж и пусконаладочные работы.



Тел: +7 (812) 336 43 04 (многоканальный)

Email: [org@lifeelectronics.ru](mailto:org@lifeelectronics.ru)