

Inductors for Power Circuits

Wound/STD • magnetic shielded

SPM series

Type: **SPM3012 (3.2x3.0 mm)**
 SPM4012 (4.4x4.1 mm)
 SPM5012 (5.4x5.1 mm)
 SPM5030 (5.2x5.0 mm)
 SPM6530 (7.1x6.5 mm)

Issue date: November 2012

- All specifications are subject to change without notice.
- Conformity to RoHS Directive: This means that, in conformity with EU Directive 2002/95/EC, lead, cadmium, mercury, hexavalent chromium, and specific bromine-based flame retardants, PBB and PBDE, have not been used, except for exempted applications.

Inductors for Power Circuits

Wound/STD • Magnetic Shielded

Conformity to RoHS Directive

SPM Series SPM3012

The SPM3012 is a large-current SMD power inductor that uses a magnetic metal material. In addition to the conventional SPM6530 and SPM5030 products, the SPM Series now includes this 3×3.2mm product with a maximum height of 1.2mm.

FEATURES

- Small and low profile design.
Size: 3.2×3.0mm.
Height: 1.2mm max.
- Uses a magnetic metal material with a high magnetic flux density.
- Has a high curie temperature, which ensures a wide operating temperature range.
- Available for automatic mounting in tape and reel package.

APPLICATIONS

Cellular phones, note book type computers, etc.

PRODUCT IDENTIFICATION

SPM	3012	T	1R0	M
(1)	(2)	(3)	(4)	(5)

(1) Series name

(2) Dimensions L×H

3012	3.0×1.2mm max.
------	----------------

(3) Packaging style

T	Embossed carrier tape
---	-----------------------

(4) Inductance value

1R0	1.0μH
-----	-------

(5) Inductance tolerance

M	±20%
---	------

PACKAGING STYLE AND QUANTITIES

Packaging style	Quantity
Taping	2000 pieces/reel

SHAPES AND DIMENSIONS

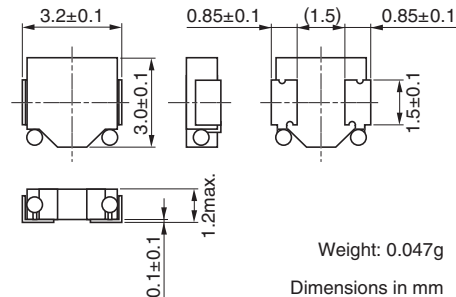

RECOMMENDED PC BOARD PATTERN

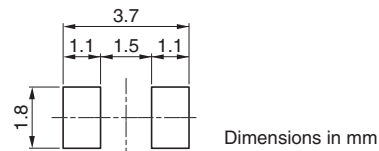

CIRCUIT DIAGRAM



RECOMMENDED SOLDERING CONDITION

REFLOW SOLDERING

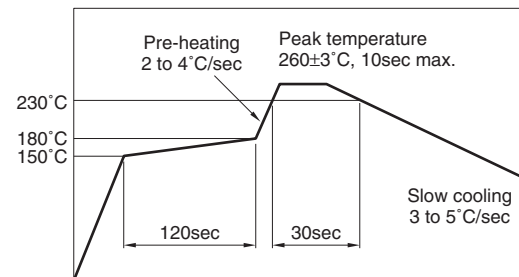

HANDLING AND PRECAUTIONS

- Please contact us before cleaning this product.
- Maintain a safe distance between this product and other components according to the working voltage.
- If this product is left in a humid environment for a long period of time, rust may appear on the surface. However, this does not affect performance.

• Conformity to RoHS Directive: This means that, in conformity with EU Directive 2002/95/EC, lead, cadmium, mercury, hexavalent chromium, and specific bromine-based flame retardants, PBB and PBDE, have not been used, except for exempted applications.

• Please contact our Sales office when your application is considered the following:
The device's failure or malfunction may directly endanger human life (e.g. application for automobile/aircraft/medical/nuclear power devices, etc.)

• All specifications are subject to change without notice.

ELECTRICAL CHARACTERISTICS

Part No.	Inductance (μH)	Tolerance (%)	Test frequency (kHz)	DC resistance($\text{m}\Omega$)		Rated current(A)*		
				max.	typ.	Based on inductance change		Based on temperature rise
						max.	typ.	typ.
SPM3012T-1R0M	1.0	± 20	100	65	57	3.4	5.4	2.8
SPM3012T-1R5M	1.5	± 20	100	90	77	2.8	4.7	2.5
SPM3012T-2R2M	2.2	± 20	100	115	100	2.5	3.4	2.2
SPM3012T-3R3M	3.3	± 20	100	210	183	1.8	2.8	1.5

* Rated current: Value obtained when current flows and the temperature has risen to 40°C or when DC current flows and the nominal value of inductance has fallen by 30%, whichever is smaller.

- Operating temperature range: -40 to +125°C (Including self-temperature rise)

TYPICAL ELECTRICAL CHARACTERISTICS

INDUCTANCE CHANGE vs. DC SUPERPOSITION CHARACTERISTICS

SPM3012T-1R0M

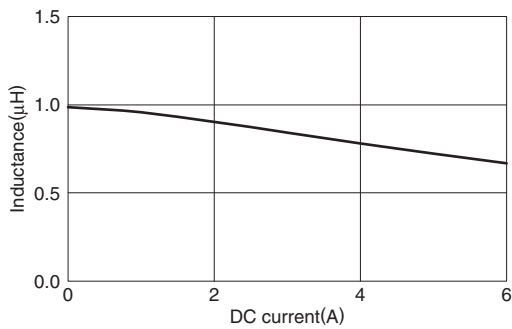

SPM3012T-1R5M

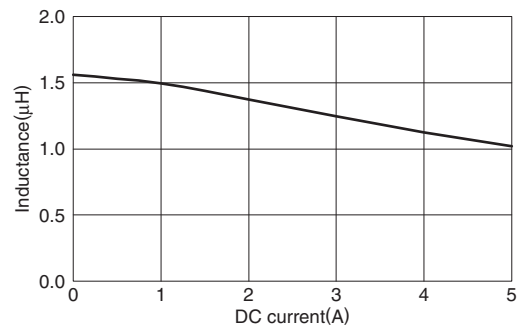

SPM3012T-2R2M

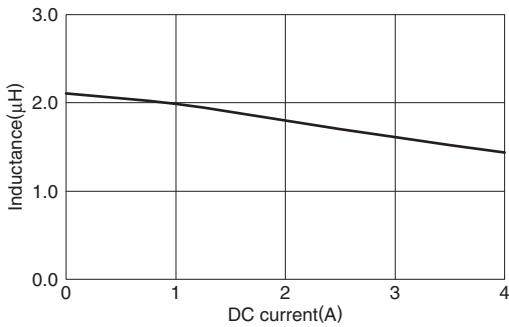

SPM3012T-3R3M

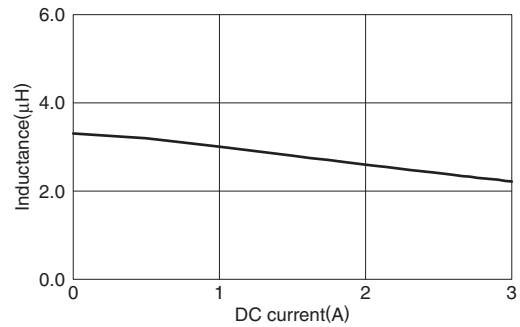

TEST CIRCUIT

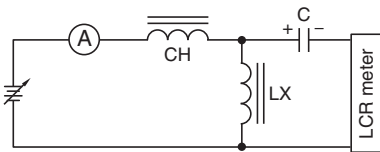

PACKAGING STYLES
REEL DIMENSIONS

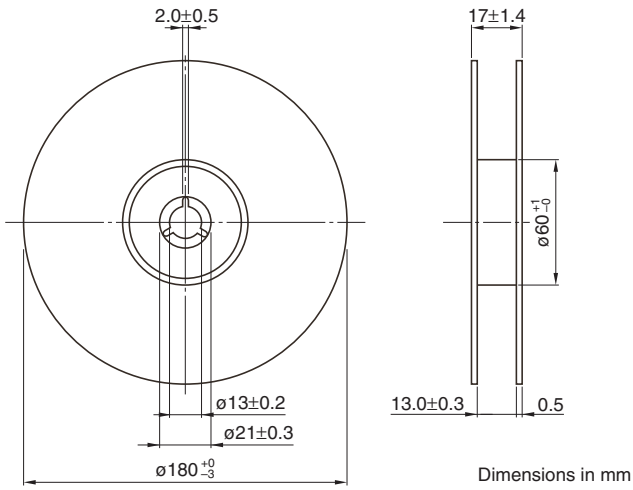

TAPE DIMENSIONS

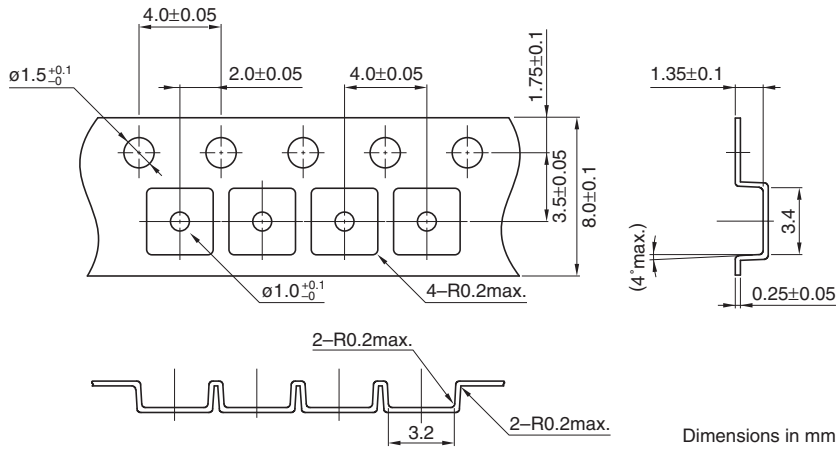

Inductors for Power Circuits

Wound/STD • Magnetic Shielded

Conformity to RoHS Directive

SPM Series SPM4012

The SPM4012 is a large-current SMD power inductor that uses a magnetic metal material. In addition to the conventional SPM3012 products, the SPM Series now includes this 4mm square product with a maximum height of 1.2mm.

FEATURES

- Small and low profile design.
Size: 4.4×4.1mm.
Height: 1.2mm max.
- Uses a magnetic metal material with a high magnetic flux density.
- Has a high curie temperature, which ensures a wide operating temperature range.
- Available for automatic mounting in tape and reel package.

APPLICATIONS

Cellular phones, note book type computers, etc.

PRODUCT IDENTIFICATION

SPM	4012	T	- 1R0	- M
(1)	(2)	(3)	(4)	(5)

(1) Series name

(2) Dimensions L×H

4012	4.0×1.2mm max.
------	----------------

(3) Packaging style

T	Embossed carrier tape
---	-----------------------

(4) Inductance value

1R0	1.0μH
-----	-------

(5) Inductance tolerance

M	±20%
---	------

PACKAGING STYLE AND QUANTITIES

Packaging style	Quantity
Taping	1000 pieces/reel

SHAPES AND DIMENSIONS

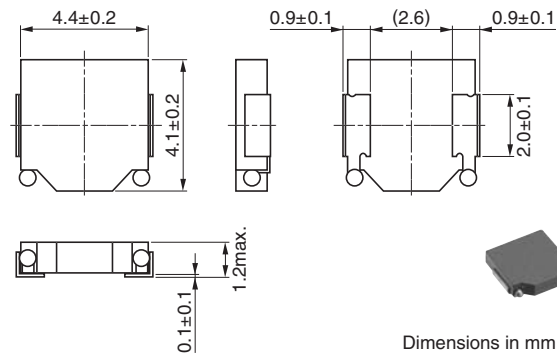

RECOMMENDED PC BOARD PATTERN

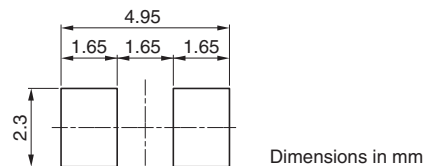

CIRCUIT DIAGRAM



RECOMMENDED SOLDERING CONDITION

REFLOW SOLDERING

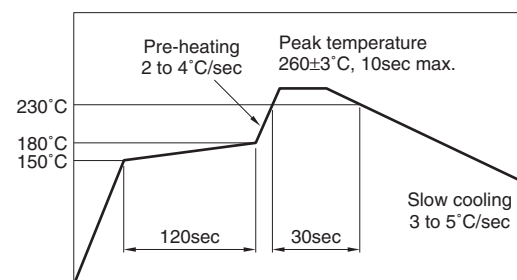

HANDLING AND PRECAUTIONS

- Please contact us before cleaning this product.
- Maintain a safe distance between this product and other components according to the working voltage.
- If this product is left in a humid environment for a long period of time, rust may appear on the surface.
However, this does not affect performance.

• Conformity to RoHS Directive: This means that, in conformity with EU Directive 2002/95/EC, lead, cadmium, mercury, hexavalent chromium, and specific bromine-based flame retardants, PBB and PBDE, have not been used, except for exempted applications.

• Please contact our Sales office when your application is considered the following:
The device's failure or malfunction may directly endanger human life (e.g. application for automobile/aircraft/medical/nuclear power devices, etc.)

• All specifications are subject to change without notice.

ELECTRICAL CHARACTERISTICS

Part No.	Inductance (μH)	Tolerance (%)	Test frequency (kHz)	DC resistance(m Ω)		Rated current(A)*		
				max.	typ.	Based on inductance change		Based on temperature rise
						max.	typ.	typ.
SPM4012T-R47M	0.47	± 20	100	25	23	8.3	10.9	4.8
SPM4012T-1R0M	1.00	± 20	100	45	38	4.8	6.0	4.1
SPM4012T-1R5M	1.50	± 20	100	70	59	3.5	4.8	3.1
SPM4012T-2R2M	2.20	± 20	100	95	82	3.3	4.4	2.7
SPM4012T-3R3M	3.30	± 20	100	145	123	2.8	3.5	2.2
SPM4012T-4R7M	4.70	± 20	100	205	178	2.0	2.5	1.7

* Rated current: Value obtained when current flows and the temperature has risen to 40°C or when DC current flows and the nominal value of inductance has fallen by 30%, whichever is smaller.

• Operating temperature range: -40 to +125°C (Including self-temperature rise)

TYPICAL ELECTRICAL CHARACTERISTICS

INDUCTANCE CHANGE vs. DC SUPERPOSITION CHARACTERISTICS

SPM4012T-R47M

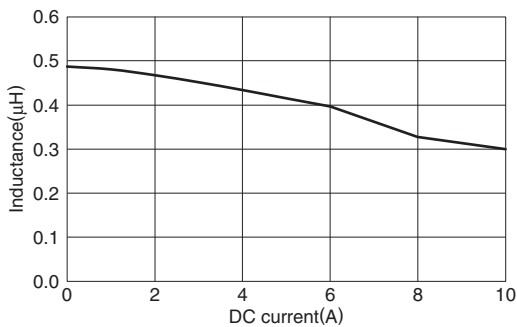

SPM4012T-1R0M

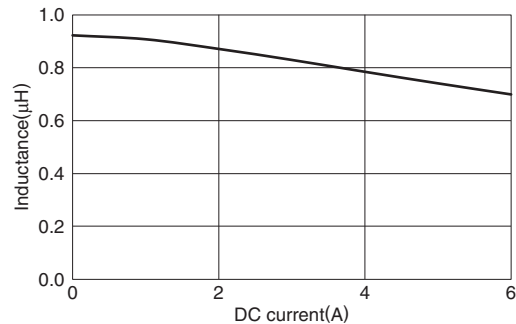

SPM4012T-1R5M

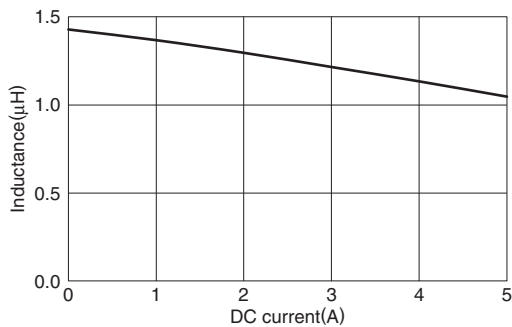

SPM4012T-2R2M

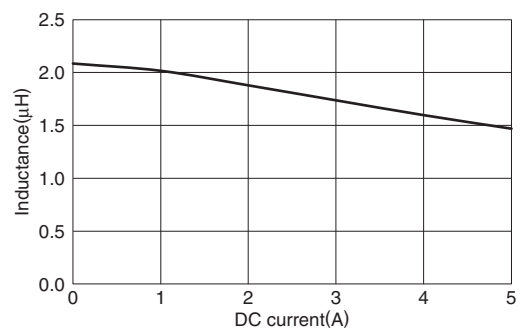

SPM4012T-3R3M

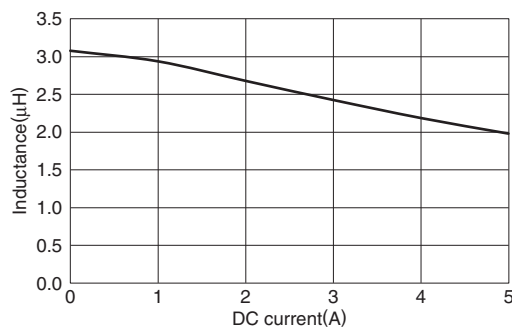

SPM4012T-4R7M

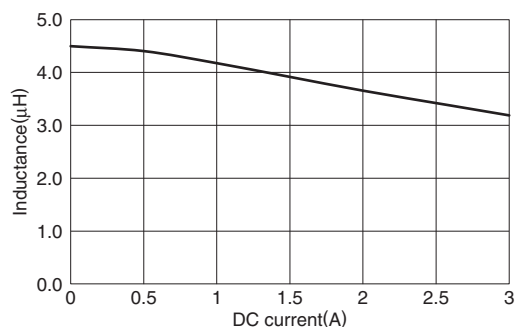

TEST CIRCUIT

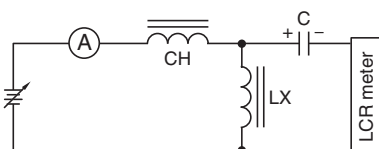

• All specifications are subject to change without notice.

PACKAGING STYLES

REEL DIMENSIONS

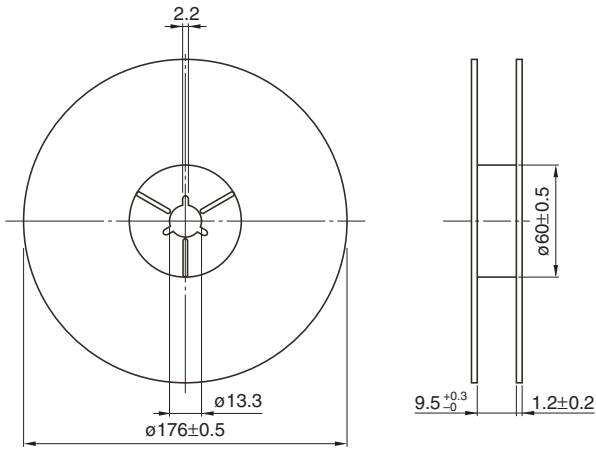

Dimensions in mm

TAPE DIMENSIONS

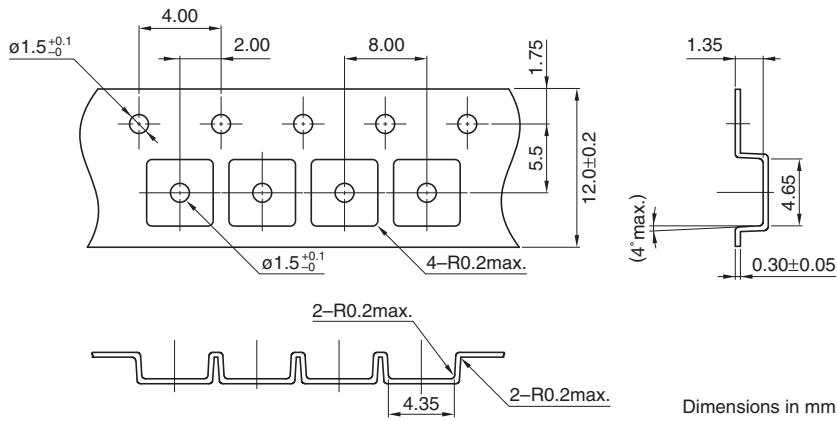

Dimensions in mm

• All specifications are subject to change without notice.

Inductors for Power Circuits

Wound/STD • Magnetic Shielded

Conformity to RoHS Directive

SPM Series SPM5012

The SPM5012 is a large-current SMD power inductor that uses a magnetic metal material. In addition to the conventional SPM3012 products, the SPM Series now includes this 5mm square product with a maximum height of 1.2mm.

FEATURES

- Small and low profile design.
Size: 5.4×5.1mm.
Height: 1.2mm max.
- Uses a magnetic metal material with a high magnetic flux density.
- Has a high curie temperature, which ensures a wide operating temperature range.
- Available for automatic mounting in tape and reel package.

APPLICATIONS

Cellular phones, note book type computers, etc.

PRODUCT IDENTIFICATION

SPM	5012	T	- 1R0	- M
(1)	(2)	(3)	(4)	(5)

(1) Series name

(2) Dimensions L×H

5012	5.0×1.2mm max.
------	----------------

(3) Packaging style

T	Embossed carrier tape
---	-----------------------

(4) Inductance value

1R0	1.0μH
-----	-------

(5) Inductance tolerance

M	±20%
---	------

PACKAGING STYLE AND QUANTITIES

Packaging style	Quantity
Taping	1000 pieces/reel

SHAPES AND DIMENSIONS

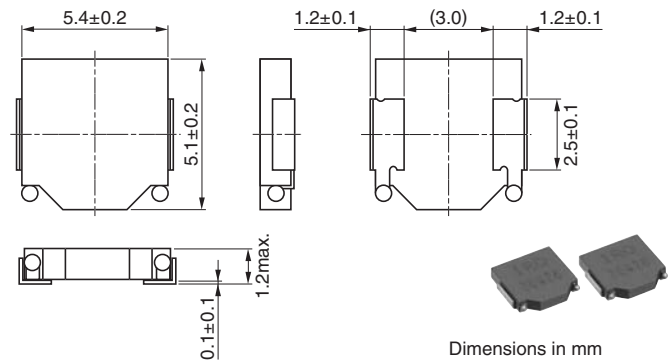

RECOMMENDED PC BOARD PATTERN

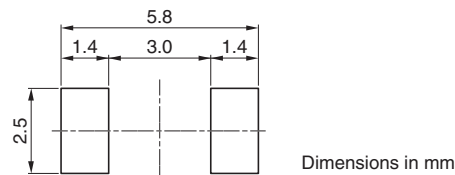

CIRCUIT DIAGRAM



RECOMMENDED SOLDERING CONDITION

REFLOW SOLDERING

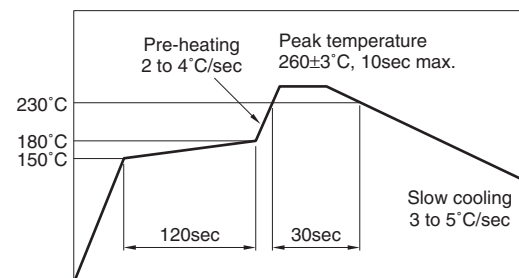

HANDLING AND PRECAUTIONS

- Please contact us before cleaning this product.
- Maintain a safe distance between this product and other components according to the working voltage.
- If this product is left in a humid environment for a long period of time, rust may appear on the surface. However, this does not affect performance.

• Conformity to RoHS Directive: This means that, in conformity with EU Directive 2002/95/EC, lead, cadmium, mercury, hexavalent chromium, and specific bromine-based flame retardants, PBB and PBDE, have not been used, except for exempted applications.

• Please contact our Sales office when your application is considered the following:
The device's failure or malfunction may directly endanger human life (e.g. application for automobile/aircraft/medical/nuclear power devices, etc.)

• All specifications are subject to change without notice.

ELECTRICAL CHARACTERISTICS

Part No.	Inductance (μH)	Tolerance (%)	Test frequency (kHz)	DC resistance(mΩ)		Rated current(A)*		
				max.	typ.	Based on inductance change		Based on temperature rise
						max.	typ.	typ.
SPM5012T-1R0M	1.00	±20	100	44.0	40.0	6.3	7.9	4.1
SPM5012T-2R2M	2.20	±20	100	78.8	71.6	4.9	6.1	2.7

* Rated current: Value obtained when current flows and the temperature has risen to 40°C or when DC current flows and the nominal value of inductance has fallen by 30%, whichever is smaller.

- Operating temperature range: -40 to +125°C (Including self-temperature rise)

TYPICAL ELECTRICAL CHARACTERISTICS

INDUCTANCE CHANGE vs. DC SUPERPOSITION CHARACTERISTICS

SPM5012T-1R0M

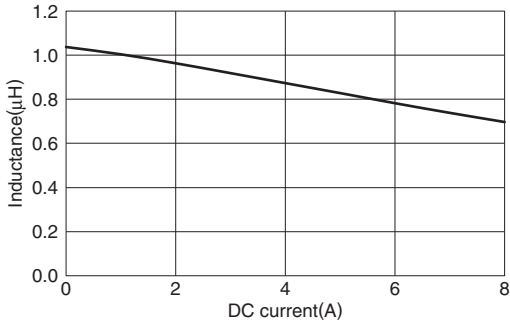

SPM5012T-2R2M

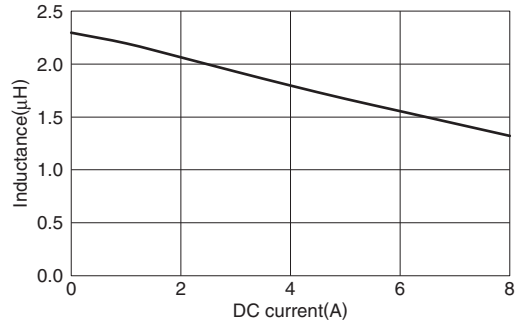

TEST CIRCUIT

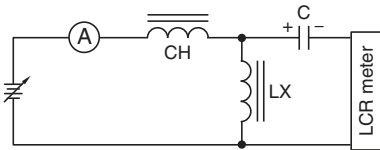

PACKAGING STYLES

REEL DIMENSIONS

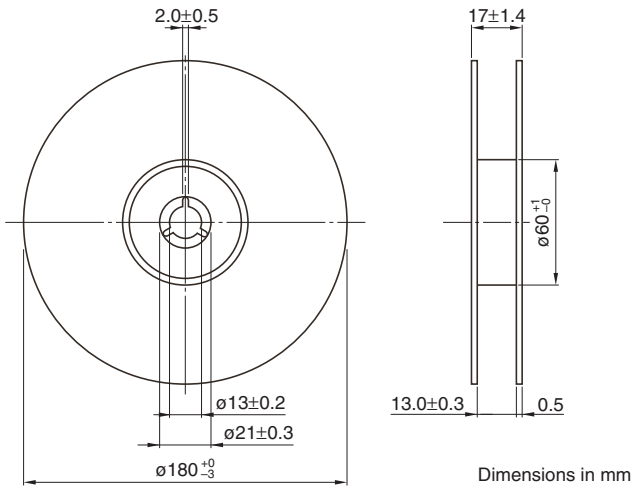

TAPE DIMENSIONS

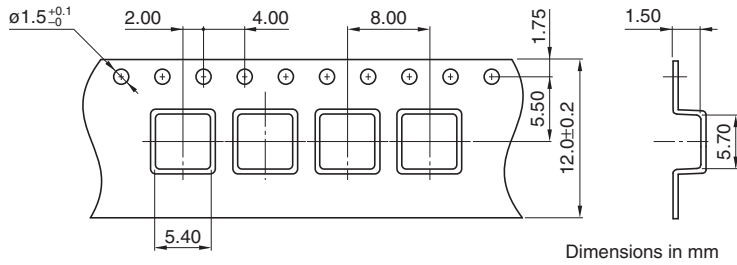

Inductors for Power Circuits

Wound/STD • Magnetic Shielded

Conformity to RoHS Directive

SPM Series SPM5030

The SPM5030 contains SMD inductors for large currents. They have a high saturation current, and the DC superimposition characteristics have low temperature variance. This series can meet the needs of customers requiring products smaller than the SPM6530.

FEATURES

- Small and low profile design
Size: 5.2×5.0mm
Height: 3.0mm max.
- High power handling capability:
Small copper loss
Using large saturation induction of Fe-based metals
- Wide operating temperature range due to high Curie temperature of around 550°C.
- Available for automatic mounting in tape and reel package.

APPLICATIONS

Note book type computers, servers, VRMs, etc.

PRODUCT IDENTIFICATION

SPM	5030	T	-	□□□	-	□
(1)	(2)	(3)	(4)	(5)		

(1) Series name

(2) Dimensions L×H

5030 5.0×3.0mm max.

(3) Packaging style

T Embossed carrier tape

(4) Inductance value

R20 0.20μH

(5) Inductance tolerance

M ±20%

PACKAGING STYLE AND QUANTITIES

Packaging style	Quantity
Taping	500 pieces/reel

SHAPES AND DIMENSIONS

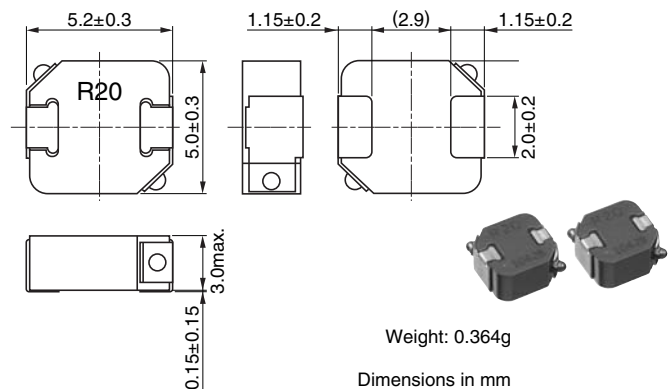

RECOMMENDED PC BOARD PATTERN

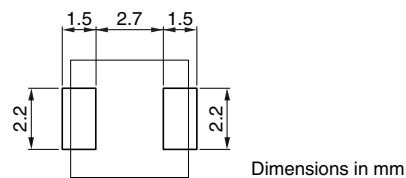

CIRCUIT DIAGRAM



RECOMMENDED SOLDERING CONDITION

REFLOW SOLDERING

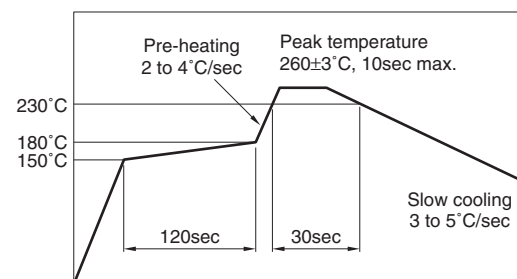

HANDLING AND PRECAUTIONS

- Please contact us before cleaning this product.
- Maintain a safe distance between this product and other components according to the working voltage.
- If this product is left in a humid environment for a long period of time, rust may appear on the surface. However, this does not affect performance.

• Conformity to RoHS Directive: This means that, in conformity with EU Directive 2002/95/EC, lead, cadmium, mercury, hexavalent chromium, and specific bromine-based flame retardants, PBB and PBDE, have not been used, except for exempted applications.

• Please contact our Sales office when your application is considered the following:
The device's failure or malfunction may directly endanger human life (e.g. application for automobile/aircraft/medical/nuclear power devices, etc.)

• All specifications are subject to change without notice.

ELECTRICAL CHARACTERISTICS

Part No.	Inductance (μH)	Tolerance (%)	Test frequency (kHz)	DC resistance ($\text{m}\Omega$)		Rated current (A)*	
				max.	typ.	Based on inductance change typ.	Based on temperature rise typ.
SPM5030T-R20M	0.20	± 20	100	2.31	2.1	21.0	22.2
SPM5030T-R35M	0.35	± 20	100	4.29	3.9	14.9	16.6
SPM5030T-R75M	0.75	± 20	100	9.35	8.5	9.7	11.3
SPM5030T-1R0M	1.0	± 20	100	11.44	10.4	8.5	10.1

* Rated current: Value obtained when current flows and the temperature has risen to 40°C or when DC current flows and the nominal value of inductance has fallen by 20%, whichever is smaller.

- Operating temperature range: -40 to $+125^\circ\text{C}$ (Including self-temperature rise)

TYPICAL ELECTRICAL CHARACTERISTICS

INDUCTANCE CHANGE vs. DC SUPERPOSITION CHARACTERISTICS

SPM5030T-R20M

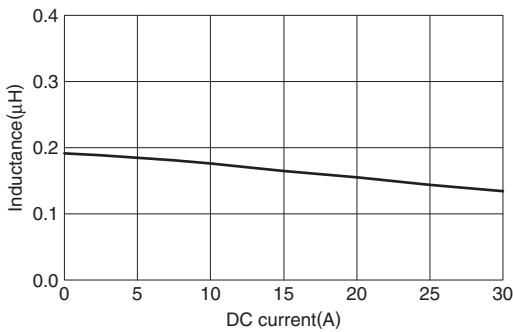

SPM5030T-R35M

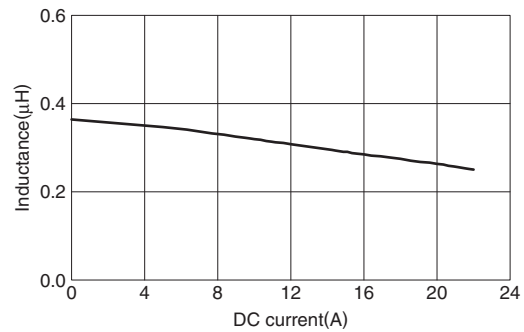

SPM5030T-R75M

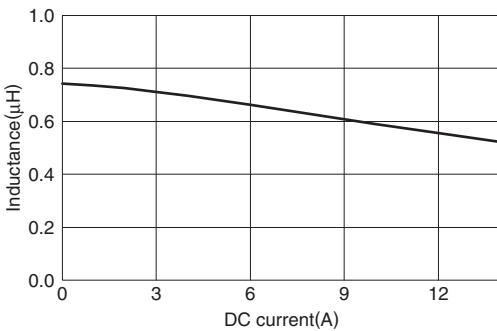

SPM5030T-1R0M

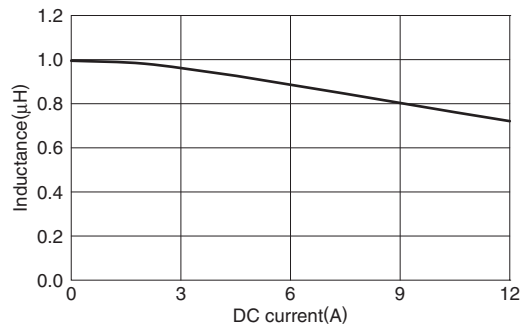

TEST CIRCUIT

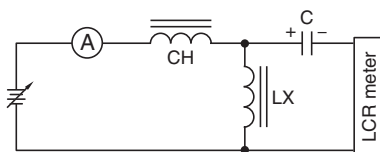

PACKAGING STYLES

REEL DIMENSIONS

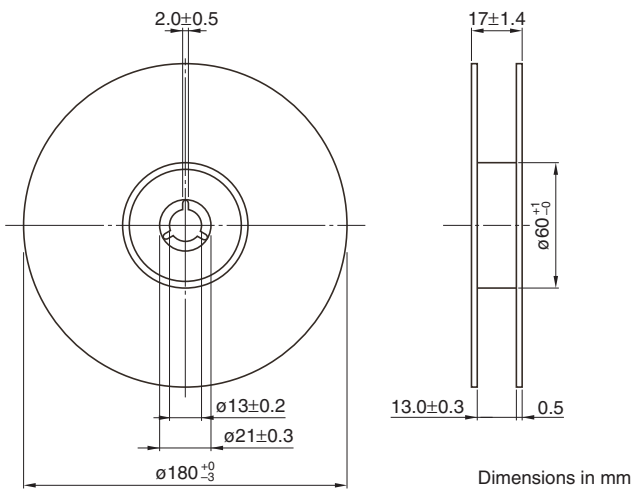

TAPE DIMENSIONS

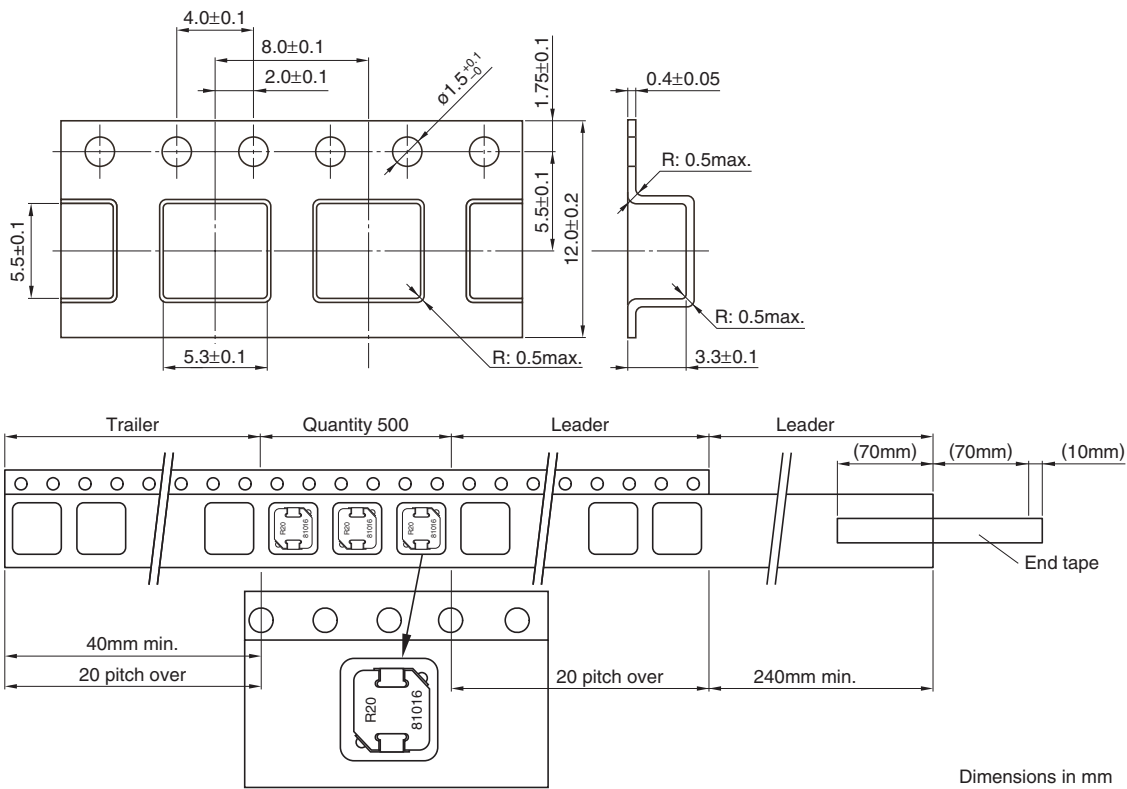

• All specifications are subject to change without notice.

Inductors for Power Circuits

Wound/STD • Magnetic Shielded

Conformity to RoHS Directive

SPM Series SPM6530

The SPM6530 is a large-current SMD power inductor that uses a magnetic metal material.

This product has good superimposition characteristics and low DC resistance.

FEATURES

- Small footprint and Low profile design
Footprint: 7.1×6.5mm
Height: 3.0mm max.
- High power handling capability:
Small copper loss
Using large saturation induction of Fe-based metals
- A high Curie temperature of about 550°C means low inductance temperature variance.
- Available for automatic mounting in tape and reel package.

APPLICATIONS

Note book type computers, VRMs, etc.

PRODUCT IDENTIFICATION

SPM	6530	T	- 3R3	- M
(1)	(2)	(3)	(4)	(5)

(1) Series name

(2) Dimensions L×H

6530 6.5×3.0mm max.

(3) Packaging style

T Embossed carrier tape

(4) Inductance value

3R3 3.3μH

(5) Inductance tolerance

M ±20%

PACKAGING STYLE AND QUANTITIES

Packaging style	Quantity
Taping	1000 pieces/reel

SHAPES AND DIMENSIONS

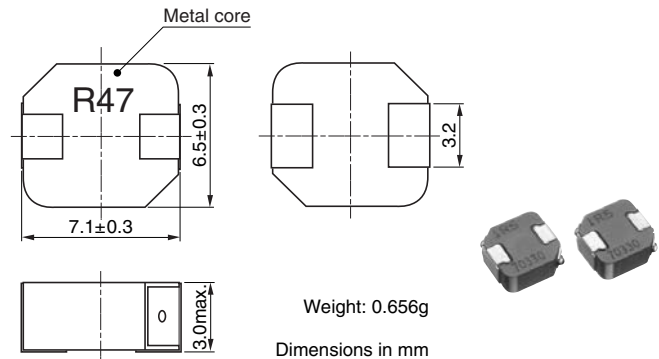

RECOMMENDED PC BOARD PATTERN

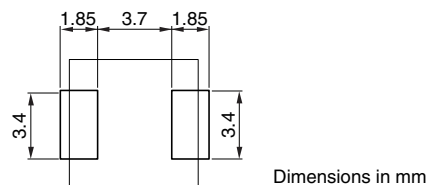

CIRCUIT DIAGRAM



RECOMMENDED SOLDERING CONDITION

REFLOW SOLDERING

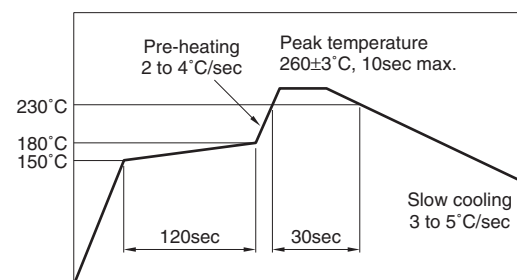

HANDLING AND PRECAUTIONS

- Please contact us before cleaning this product.
- Maintain a safe distance between this product and other components according to the working voltage.
- If this product is left in a humid environment for a long period of time, rust may appear on the surface. However, this does not affect performance.

• Conformity to RoHS Directive: This means that, in conformity with EU Directive 2002/95/EC, lead, cadmium, mercury, hexavalent chromium, and specific bromine-based flame retardants, PBB and PBDE, have not been used, except for exempted applications.

• Please contact our Sales office when your application is considered the following:

The device's failure or malfunction may directly endanger human life (e.g. application for automobile/aircraft/medical/nuclear power devices, etc.)

• All specifications are subject to change without notice.

ELECTRICAL CHARACTERISTICS

Part No.	Inductance (μH)	Tolerance (%)	Test frequency (kHz)	DC resistance(mΩ)		Rated current(A)*	
				max.	typ.	Based on inductance change typ.	Based on temperature rise typ.
SPM6530T-R25M230	0.25	±20	100	2.31	2.1	28.5	23
SPM6530T-R47M170	0.47	±20	100	3.63	3.3	20.5	20
SPM6530T-R68M140	0.68	±20	100	5.39	4.9	16.6	16
SPM6530T-1R0M120	1	±20	100	7.81	7.1	14.1	13
SPM6530T-1R5M100	1.5	±20	100	10.67	9.7	11.5	11
SPM6530T-2R2M	2.2	±20	100	19	17.3	8.4	8.2
SPM6530T-3R3M	3.3	±20	100	29.7	27	7.3	6.8
SPM6530T-4R7M	4.7	±20	100	39.4	35.8	6.2	5.6

* Rated current: Value obtained when current flows and the temperature has risen to 40°C or when DC current flows and the nominal value of inductance has fallen by 20%, whichever is smaller.

- Operating temperature range: -40 to +125°C (Including self-temperature rise)
- The cleaning agent can not be used for these parts.

TYPICAL ELECTRICAL CHARACTERISTICS

INDUCTANCE CHANGE vs. DC SUPERPOSITION CHARACTERISTICS

SPM6530T-R25M230

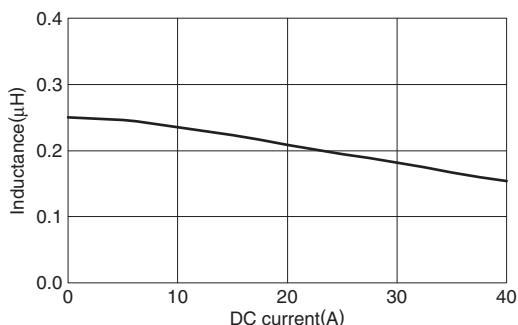

SPM6530T-R47M170

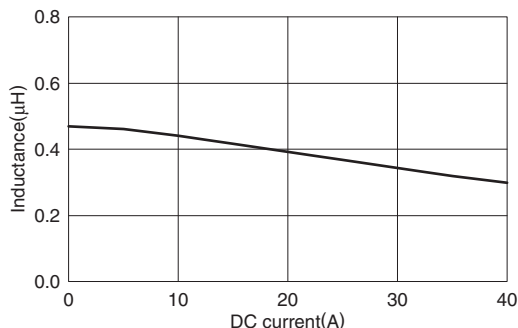

SPM6530T-R68M140

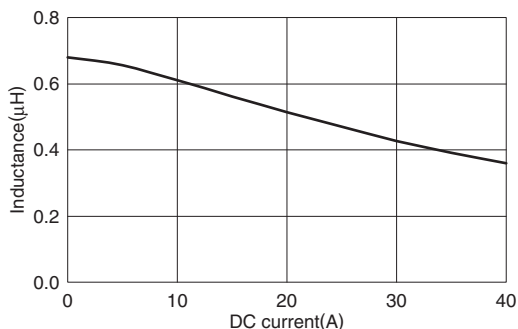

SPM6530T-1R0M120

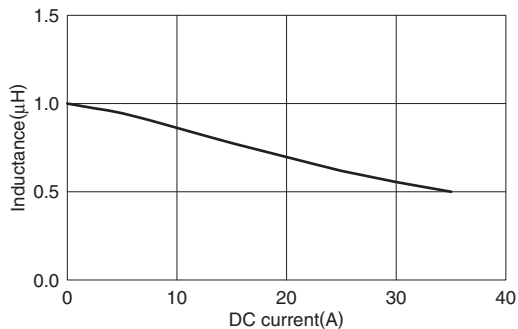

SPM6530T-1R5M100

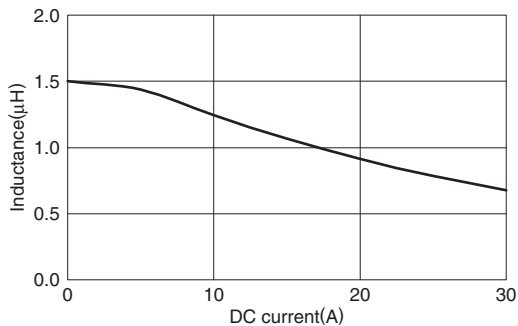

SPM6530T-2R2M

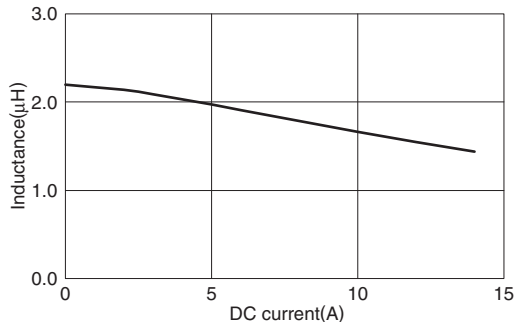

• All specifications are subject to change without notice.

TYPICAL ELECTRICAL CHARACTERISTICS

INDUCTANCE CHANGE vs. DC SUPERPOSITION CHARACTERISTICS

SPM6530T-3R3M

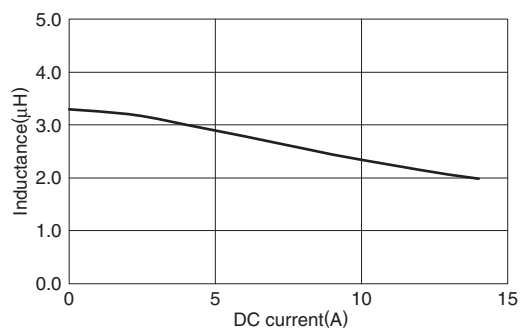

SPM6530T-4R7M

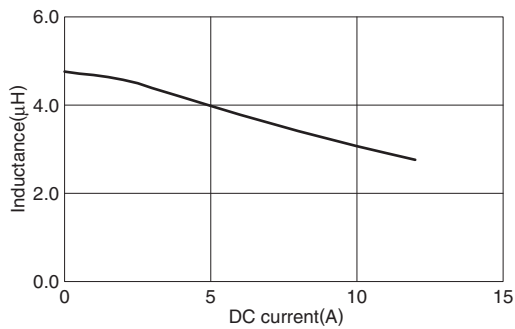

TEST CIRCUIT

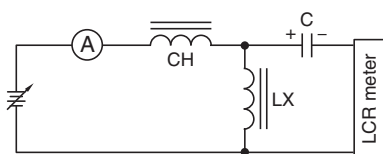

PACKAGING STYLES

REEL DIMENSIONS

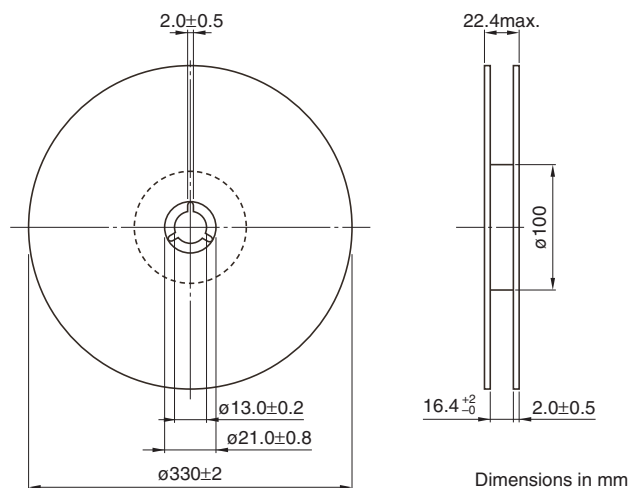

TAPE DIMENSIONS

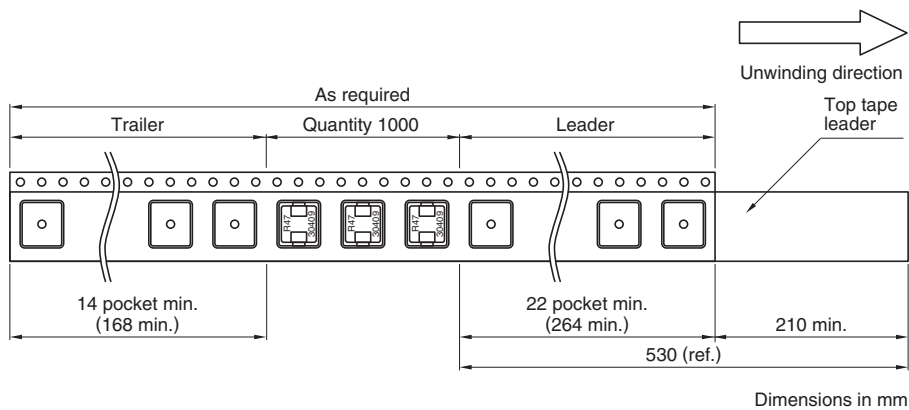

• All specifications are subject to change without notice.

Компания «Life Electronics» занимается поставками электронных компонентов импортного и отечественного производства от производителей и со складов крупных дистрибьюторов Европы, Америки и Азии.

С конца 2013 года компания активно расширяет линейку поставок компонентов по направлению коаксиальный кабель, кварцевые генераторы и конденсаторы (керамические, пленочные, электролитические), за счёт заключения дистрибьюторских договоров

Мы предлагаем:

- Конкуренспособные цены и скидки постоянным клиентам.
- Специальные условия для постоянных клиентов.
- Подбор аналогов.
- Поставку компонентов в любых объемах, удовлетворяющих вашим потребностям.
- Приемлемые сроки поставки, возможна ускоренная поставка.
- Доставку товара в любую точку России и стран СНГ.
- Комплексную поставку.
- Работу по проектам и поставку образцов.
- Формирование склада под заказчика.
- Сертификаты соответствия на поставляемую продукцию (по желанию клиента).
- Тестирование поставляемой продукции.
- Поставку компонентов, требующих военную и космическую приемку.
- Входной контроль качества.
- Наличие сертификата ISO.

В составе нашей компании организован Конструкторский отдел, призванный помогать разработчикам, и инженерам.

Конструкторский отдел помогает осуществить:

- Регистрацию проекта у производителя компонентов.
- Техническую поддержку проекта.
- Защиту от снятия компонента с производства.
- Оценку стоимости проекта по компонентам.
- Изготовление тестовой платы монтаж и пусконаладочные работы.



Тел: +7 (812) 336 43 04 (многоканальный)
Email: org@lifeelectronics.ru