

Product Specification

OC-48 LR-2/STM L-16.2 Multirate 2x10 SFF Transceiver

FTLF1621S1xCL

PRODUCT FEATURES

- Up to 2.67Gb/s bi-directional data links
- Standard 2x10 pin SFF footprint (MSA compliant)
- Analog diagnostics functions
- Uncooled 1550nm DFB laser transmitter
- APD Receiver
- Duplex LC connector
- Very low jitter
- Metal enclosure, for lower EMI
- Single 3.3V power supply
- Low power dissipation <900mW typical
- Extended operating temperature range: -10°C to 70°C



APPLICATIONS

- SONET OC-48 LR-2 / SDH STM L-16.2
- SONET OC-12 LR-2 / SDH STM L-4.2
- SONET OC-3 LR-2 / SDH STM L-1.2
- Gigabit Ethernet / 1x/2x Fibre Channel

Finisar's FTLF1621S1xCL Small Form Factor (SFF) transceivers are compatible with the Small Form Factor Multi-Sourcing Agreement (MSA)¹. They comply with SONET OC-48 LR-2 (SDH STM L-16.2) standards², and are compatible with Gigabit Ethernet as specified in IEEE Std 802.3³, Fibre Channel FC-PI 13.0⁴, SONET OC-12 and SONET OC-3 standards². The transceivers are RoHS compliant and lead-free per Directive 2002/95/EC⁵ and Finisar Application Note AN-2038⁶

PRODUCT SELECTION

FTLF1621S1xCL

x	G	2 Grounding Pins, Short EMI shield
	M	6 Grounding Pins, Short EMI shield
	K	2 Grounding Pins, Long EMI shield
	H	6 Grounding Pins, Long EMI shield

I. Pin Descriptions

Pin	Symbol	Name/Description	Logic Family
MS	MS	Mounting Studs for mechanical attachment. Chassis ground is internally isolated from circuit ground. Connection to chassis ground is recommended.	NA
1	PD	Receiver Power Monitor. This pin must be connected to a positive voltage supply (Vcc), preferably via a small resistor. Supplies photocurrent and may be used to monitor received power.	Analog Current
2,3,6	V _{EER}	Receiver Ground (Common with Transmitter Ground)	NA
4,5	NC	Not Connected.	
7	V _{CCR}	Receiver Power Supply	NA
8	SD	Signal Detect. Logic 1 indicates normal operation.	LVTTL
9	RD-	Receiver Inverted DATA out. AC Coupled	CML
10	RD+	Receiver Non-inverted DATA out. AC Coupled	CML
11	V _{CCT}	Transmitter Power Supply	NA
12,16	V _{EET}	Transmitter Ground (Common with Receiver Ground)	NA
13	T _{DIS}	Transmitter Disable	LVTTL
14	TD+	Transmitter Non-Inverted DATA in. AC Coupled.	CML ECL
15	TD-	Transmitter Inverted DATA in. AC Coupled.	CML ECL
17	Bmon-	Laser Bias Monitoring (-).	Analog Voltage
18	Bmon+	Laser Bias Monitoring (+) .(Bmon+ - Bmon-) = 10Ω x laser bias current.	Analog Voltage
19	Pmon-	Laser Power Monitoring (-). Current implementation connects this pin to ground	Analog Voltage
20	Pmon+	Laser Power Monitoring (+) .(Pmon+ - Pmon-) = 200Ω x mon. photodiode current.	Analog Voltage

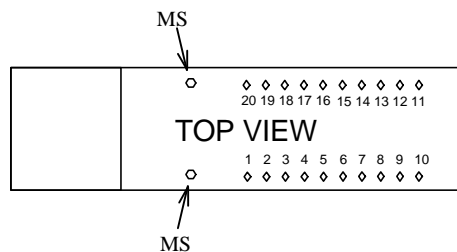

II. Absolute Maximum Ratings

Parameter	Symbol	Min	Typ	Max	Unit	Notes
Maximum Supply Voltage	V _{CC}	-0.5		4.5	V	
Storage Temperature	T _S	-40		85	°C	
Case Operating Temperature	T _{OP}	-10		70	°C	
Relative Humidity	RH	0		85	%	1
Lead Soldering Temperature/Time				260/10	°C/s	

III. Electrical Characteristics (T_{OP} = -10 to 70 °C, V_{CC} = 3.00 to 3.60 Volts)

Parameter	Symbol	Min	Typ	Max	Unit	Notes
Supply Voltage	V _{CC}	3.00		3.60	V	
Supply Current	I _{CC}		270	340	mA	
Transmitter						
Input differential impedance	R _{in}		100		Ω	2
Single ended data input swing	V _{in,pp}	250		1200	mV	
Transmit Disable Voltage	V _D	V _{CC} – 1.3		V _{CC}	V	
Transmit Enable Voltage	V _{EN}	V _{EE}		V _{EE} + 0.8	V	3
Transmit Disable Assert Time				10	us	
Receiver						
Single ended data output swing	V _{out,pp}	300	400	800	mV	4
Data output rise time	t _r		100	175	ps	5
Data output fall time	t _f		100	175	ps	5
SD Assert	V _{SD assert}	V _{CC} – 0.5		V _{CC}	V	6
SD De-Assert	V _{SD deassert}	V _{EE}		V _{EE} +0.5	V	6
Power Supply Rejection	PSR	100			mVpp	7
Total Generated Receiver Jitter (peak to peak)	J _{RXP-P}			0.07	UI	8
Total Generated Receiver Jitter (rms)	J _{RXRMS}			0.007	UI	8

Notes:

1. Non condensing.
2. AC coupled.
3. Or open circuit.
4. Into 100 ohms differential termination.
5. 20 – 80 %
6. Signal Detect is LVTTTL. Logic 0 indicates normal operation; logic 1 indicates no signal detected.
7. All transceiver specifications are compliant with a power supply sinusoidal modulation of 20 Hz to 1.5 MHz up to specified value applied through the power supply filtering network shown on page 23 of the Small Form-factor Pluggable (SFP) Transceiver MultiSource Agreement (MSA)², September 14, 2000.
8. Parameters per GR-253² section 5.6 for OC-48B.

IV. Optical Characteristics (T_{OP} = -10 to 70°C, V_{CC} = 3.00 to 3.60 Volts)

Parameter	Symbol	Min	Typ	Max	Unit	Notes
Transmitter						
Output Opt. Pwr: 9/125 SMF	P _{OUT}	-2		+3	dBm	1
Optical Wavelength	λ	1500		1580	nm	
Spectral Width (-20dB)	σ			1	nm	
Optical Extinction Ratio	ER	8.2			dB	
Sidemode Suppression ratio	SSR _{min}	30			dB	
Optical Rise/Fall Time	t _r / t _f			180	ps	2
Relative Intensity Noise	RIN			-120	dB/Hz	
Total Generated Transmitter Jitter (peak to peak)	J _{TXP-P}			0.07	UI	3
Total Generated Transmitter Jitter (rms)	J _{TXrms}			0.007	UI	3
Dispersion Penalty at 80 km				2.0	dB	4
Receiver						
Average Rx Sensitivity @ 2.67Gb/s	R _{SENS1}	-9		-28	dBm	5
Average Rx Sensitivity @ OC-48	R _{SENS1}	-9		-28	dBm	5
Average Rx Sensitivity @ 2X Fibre Channel	R _{SENS2}	-9		-28	dBm	6
Average Rx Sensitivity @ Gigabit Ethernet	R _{SENS3}	-9		-30	dBm	6
Average Rx Sensitivity @ OC-12	R _{SENS4}	-9		-29	dBm	7
Average Rx Sensitivity @ OC-3	R _{SENS5}	-15		-30	dBm	7
Optical Center (Input) Wavelength	λ_C	1270		1620	nm	
Receiver Reflectance	R _{Rx}			-27	dB	
SD Assert	SD _A			-28	dBm	
SD De-Assert	SD _D	-41			dBm	
SD Hysteresis		0.5			dB	

Notes:

1. Class 1 Laser Safety per FDA/CDRH and EN (IEC) 60825 regulations.
2. Unfiltered, 20 - 80%
3. Parameters per GR-253² section 5.6 for OC-48B.
4. SMF-28 fiber used. 80kms represents 1600ps/nm at 1550nm. Measured at 2.488Gb/s with a PRBS 2²³-1 pattern extrapolated to BER<10⁻¹².
5. With worst-case extinction ratio at 10⁻¹⁰ BER. Measured with a PRBS 2³¹-1 test pattern interspersed with 72 consecutive ones and 72 consecutive zeros.
6. With worst-case extinction ratio. Measured with a PRBS 2⁷-1 test pattern.
7. With worst-case extinction ratio. Measured with a PRBS 2²³-1 test pattern.

V. General Specifications

Parameter	Symbol	Min	Typ	Max	Units	Notes
Data Rate	BR	155		2667	Mb/s	1
Bit Error Rate	BER			10^{-12}		2
Max. Supported Link Length on 9/125 μ m SMF @ OC-48	L _{MAX1}		80		km	3
Max. Supported Link Length on 9/125 μ m SMF @ 2X Fibre Channel	L _{MAX2}		85		km	3
Max. Supported Link Length on 9/125 μ m SMF @ Gigabit Ethernet	L _{MAX3}		100		km	3
Max. Supported Link Length on 9/125 μ m SMF @ OC-12	L _{MAX4}		100		km	3
Max. Supported Link Length on 9/125 μ m SMF @ OC-3	L _{MAX5}		100		km	3

Notes:

- SONET OC-48 LR-2/SDH STM L-16.2 compliant. Compatible with Gigabit Ethernet, 1X/2X Fibre Channel, SONET OC-12 and OC-3. Supports FEC at 2.67Gb/s.
- Tested with a PRBS $2^{31}-1$ test pattern interspersed with 72 consecutive ones and 72 consecutive zeros unless otherwise specified.
- Attenuation of 0.275 dB/km is used for the link length calculations (per GR-253 CORE). A 2dB penalty is included for dispersion on >2Gb/s data rates. Distances are indicative only. Please refer to the Optical Specifications in Table IV to calculate a more accurate link budget based on specific conditions in your application.

VI. Environmental Specifications

Parameter	Symbol	Min	Typ	Max	Units
Case Operating Temperature	T _{op}	-10		70	°C
Storage Temperature	T _{sto}	-40		85	°C

VII. Regulatory Compliance

Finisar transceivers are Class 1 Laser Products and comply with US FDA regulations. These products are certified by TÜV and CSA to meet the Class 1 eye safety requirements of EN (IEC) 60825 and the electrical safety requirements of EN (IEC) 60950. Copies of certificates are available at Finisar Corporation upon request.

VIII. Analog Diagnostics Functions ($T_{op} = -10^{\circ}\text{C}$ to 70°C , $V_{CC} = 3.00$ to 3.60 Volts)

Parameter	Symbol	Min	Typ	Max	Unit	Notes
Transmitter						
Monitor photodiode current monitor	Pmon+, Pmon-	0		V_{CC}	V	1
Laser bias current monitor	Bmon+, Bmon-	0		V_{CC}	V	2
Receiver						
Received photocurrent	Rpd	0		1	mA	3
Photodiode responsivity	R	0.5	0.9	1.0	A/W	
Applied voltage at PD pin	Vpd	2.4		V_{CC}	V	3

Notes:

- Pins 19 and 20 provide an analog voltage output proportional to the monitor photodiode current, per the following formula: $I_{BIAS} = .V(P_{mon+} - P_{mon-}) / 200\Omega$. The figure below shows the equivalent circuit.
- Pins 17 and 18 provide an analog voltage output proportional to the laser bias current, per the following formula: $I_{BIAS} = .V(B_{mon+} - B_{mon-}) / 10\Omega$. The figure below shows the equivalent circuit.
- Pin 1 is used to monitor the received photocurrent. It must be connected to a positive voltage within the range specified above. The current that flows into this pin is the received photocurrent. The received power is given by the photocurrent multiplied by the photodiode responsivity.

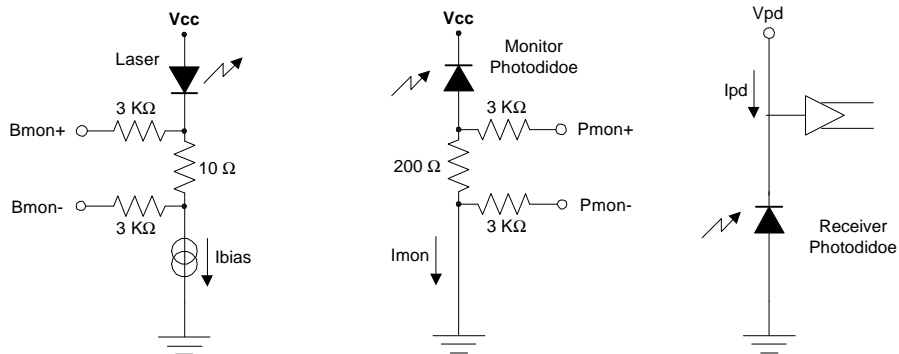
**Analog monitoring function connections.**

IX. Mechanical Specifications

Finisar’s OC-48/STM-16 Small Form Factor (SFF) transceivers comply with the standard dimensions defined by the Small Form Factor Multi-Sourcing Agreement (MSA).

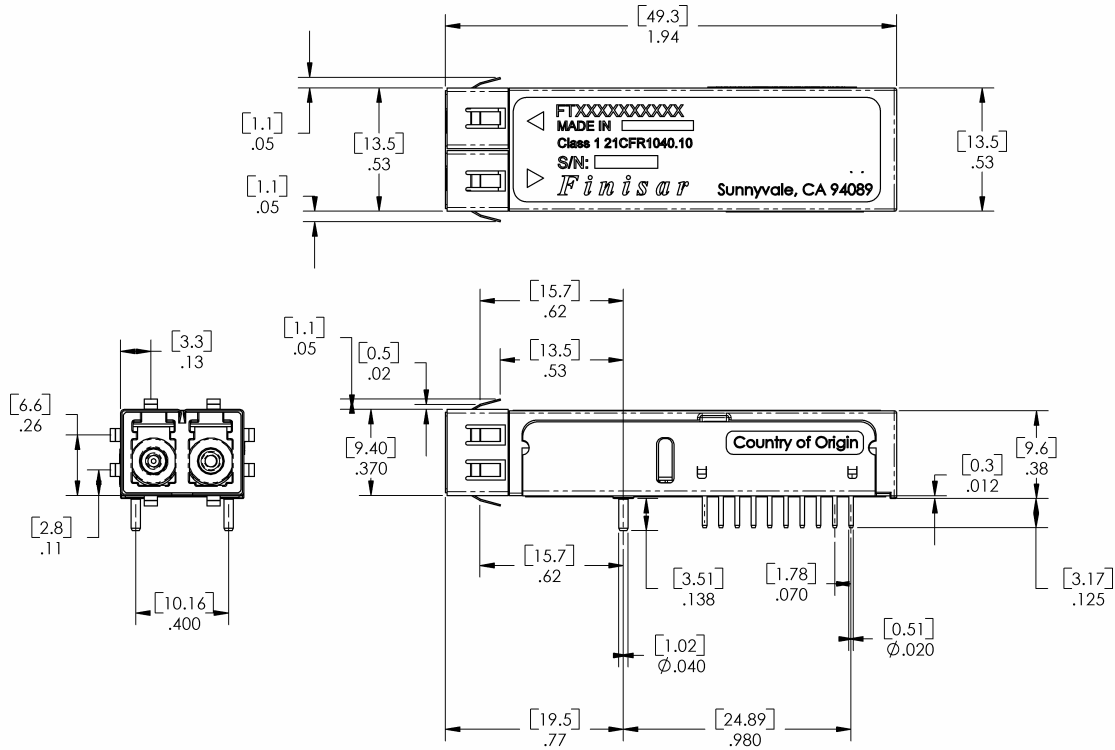

FTLF1621S1GCL – 2 pin version

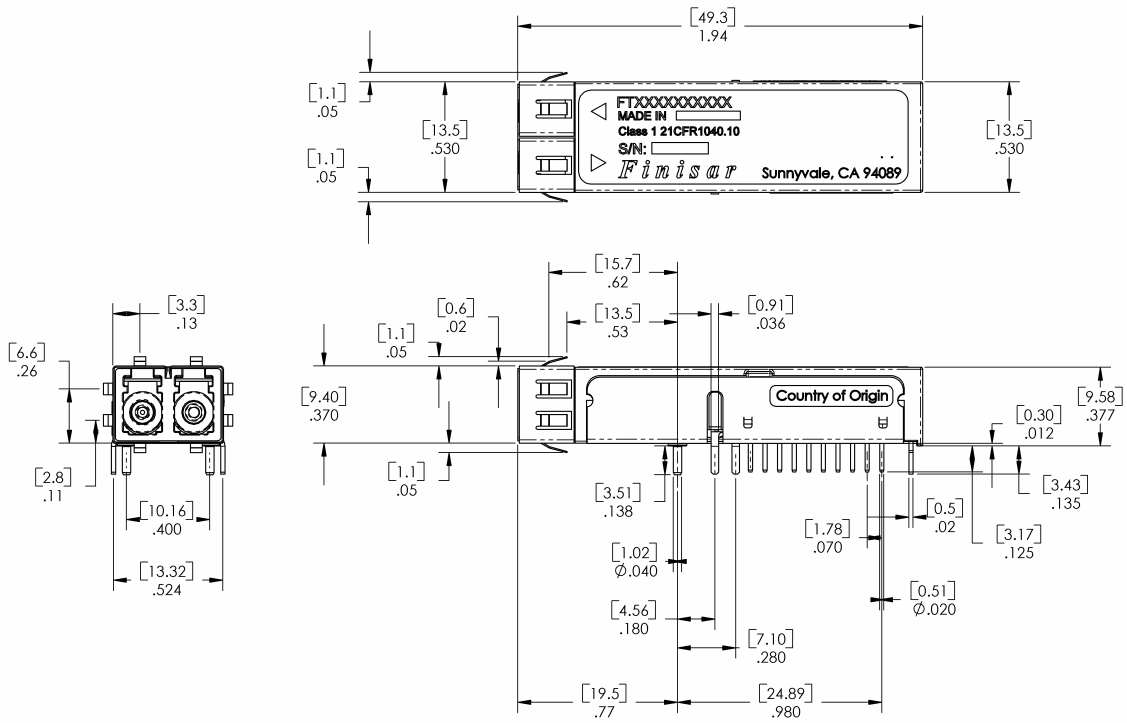

FTLF1621S1HCL – 6 pin version

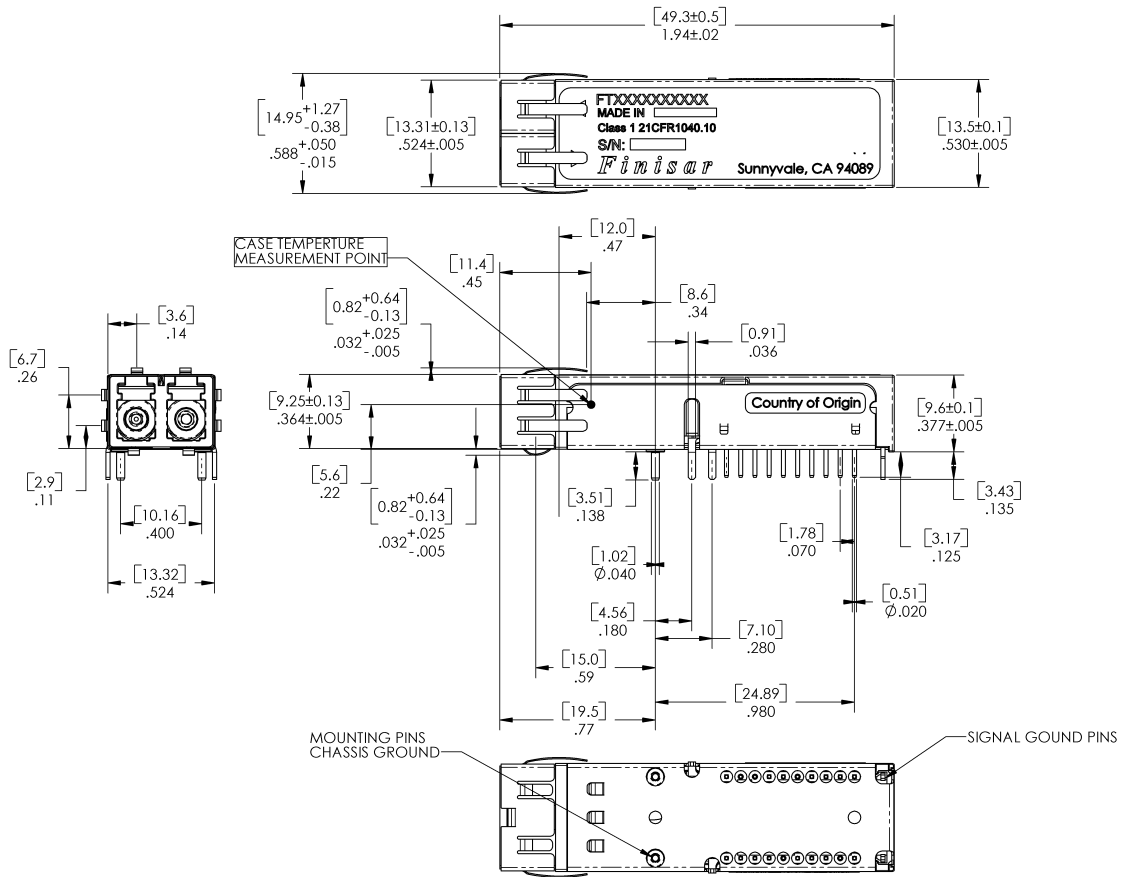

FTLF1621S1HCL – 6 pin version (Long EMI Shield)

X. PCB Layout and Bezel Recommendations

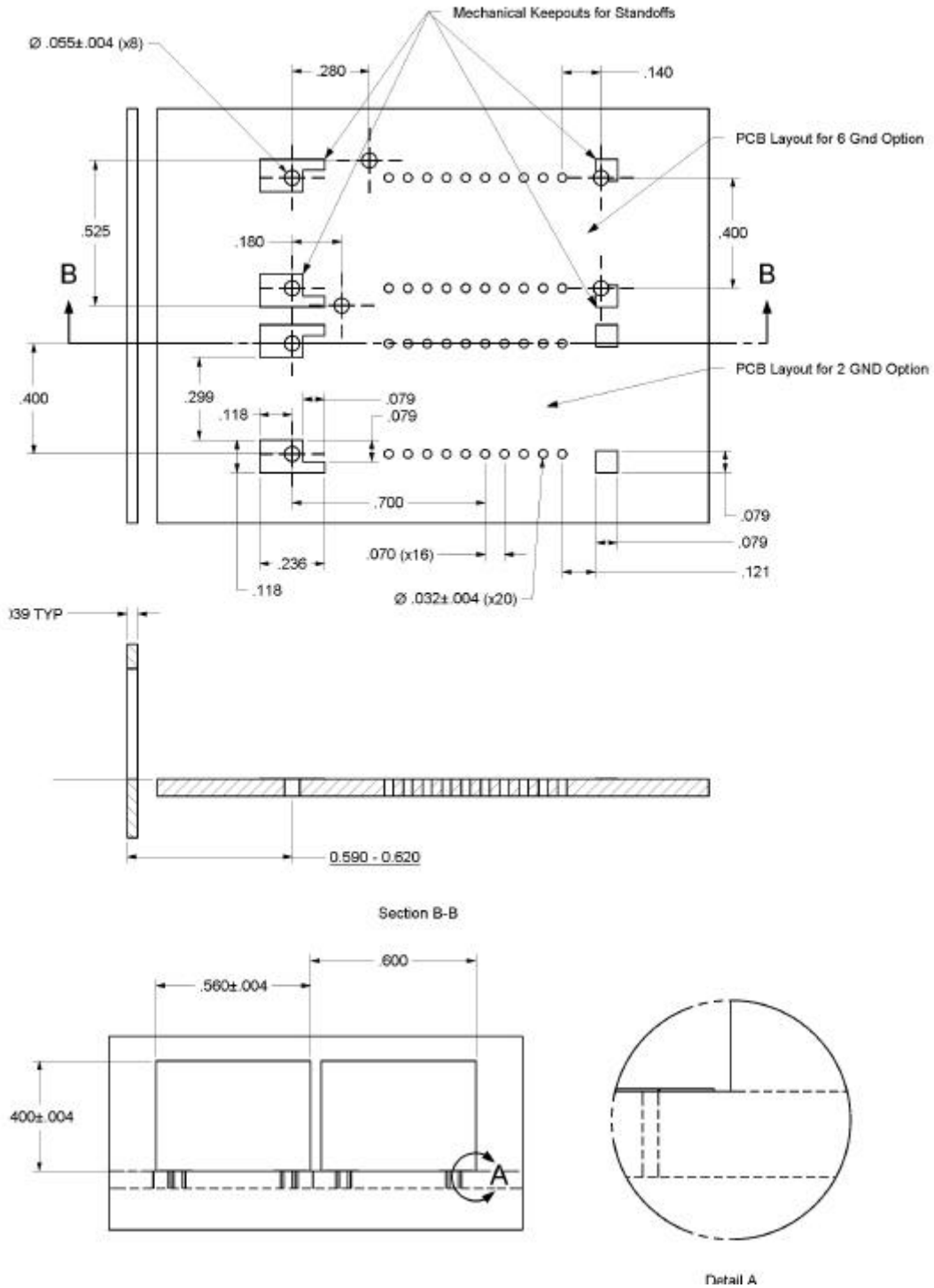

Minimum Recommended Module-to-Module Spacing is 0.6 inches

XI. References

1. Small Form Factor Pluggable (SFF) Transceiver Multi-Source Agreement (MSA), January 1998. Documentation is currently available from Finisar upon request.
2. “SONET Transport Systems: Common Generic Criteria”, Telcordia Technologies, GR-253-CORE, Issue 3, Sept 2000. Also refer to ITU-T G.957 Specifications
3. IEEE Std 802.3, 2002 Edition, Clause 38, PMD Type 1000BASE-LX. IEEE Standards Department, 2002. (Transmit Optical Output has a minimum Extinction Ratio of 8.2 dB only).^(*)
4. “Fibre Channel Draft Physical Interface Specification (FC-PI 13.0)”. American National Standard for Information Systems.^(*)
5. Directive 2002/95/EC of the European Council Parliament and of the Council. “On the restriction of the use of certain hazardous substances in electrical and electronic equipment”. January 27, 2003.
6. “Application Note AN-2038: Finisar Implementation of RoHS Compliant Transceivers:”. Finisar Corporation, January 21, 2005.

(*) Neither IEEE 802.3 nor FC-PI 13.0 specifies a 1550nm DFB single mode interface. The FTLF1621S1xCL complies with these standards except for receiver sensitivity, ER and transmit output power. See Section IV for details.

XII. For More Information

Finisar Corporation
1308 Moffett Park Drive
Sunnyvale, CA 94089-1133
Tel. 1-408-548-1000
Fax 1-408-541-6138
sales@finisar.com
www.finisar.com

Компания «Life Electronics» занимается поставками электронных компонентов импортного и отечественного производства от производителей и со складов крупных дистрибьюторов Европы, Америки и Азии.

С конца 2013 года компания активно расширяет линейку поставок компонентов по направлению коаксиальный кабель, кварцевые генераторы и конденсаторы (керамические, пленочные, электролитические), за счёт заключения дистрибьюторских договоров

Мы предлагаем:

- Конкурентоспособные цены и скидки постоянным клиентам.
- Специальные условия для постоянных клиентов.
- Подбор аналогов.
- Поставку компонентов в любых объемах, удовлетворяющих вашим потребностям.
- Приемлемые сроки поставки, возможна ускоренная поставка.
- Доставку товара в любую точку России и стран СНГ.
- Комплексную поставку.
- Работу по проектам и поставку образцов.
- Формирование склада под заказчика.
- Сертификаты соответствия на поставляемую продукцию (по желанию клиента).
- Тестирование поставляемой продукции.
- Поставку компонентов, требующих военную и космическую приемку.
- Входной контроль качества.
- Наличие сертификата ISO.

В составе нашей компании организован Конструкторский отдел, призванный помогать разработчикам, и инженерам.

Конструкторский отдел помогает осуществить:

- Регистрацию проекта у производителя компонентов.
- Техническую поддержку проекта.
- Защиту от снятия компонента с производства.
- Оценку стоимости проекта по компонентам.
- Изготовление тестовой платы монтаж и пусконаладочные работы.



Тел: +7 (812) 336 43 04 (многоканальный)
Email: org@lifeelectronics.ru