

2

1

THIS COPY IS PROVIDED ON A RESTRICTED BASIS AND IS NOT TO BE USED IN ANY WAY DETRIMENTAL TO THE INTERESTS OF PANDUIT CORP.

- VISIT OUR ON-LINE CATALOG AT WWW.PANDUIT.COM FOR A LIST OF CURRENT PARTS APPLICABLE FOR USE WITH THIS PRODUCT.
- PRIMARY DIMENSIONS ARE IN MILLIMETERS.
- FACTORY SETTINGS:
  - FRONT FACE OF FRONT E-RAILS ARE 175mm [6.89in] FROM FRONT FACE OF FRAME.
  - FRONT FACE OF REAR E-RAILS ARE 412.75mm [16.25in] FROM FRONT FACE OF FRONT E-RAILS.
- ADJUSTMENTS:
  - RAIL ADJUSTMENT MEASUREMENTS ARE TAKEN FROM THE FRONT FACE OF EACH EQUIPMENT RAIL.
  - FRONT E-RAILS CAN ADJUST AS FAR FORWARD AS 74mm [2.9in] FROM FRONT FACE OF FRAME.
  - WHEN FRONT E-RAILS ARE 74mm [2.9in] FROM FRONT FACE OF FRAME, REAR E-RAILS CAN ADJUST FROM 62mm [2.44in] TO 420mm [16.53in] AND FROM 568mm [22.36in] TO 904mm [35.59in] (1050mm [41.34in] WITHOUT PDU'S)
- CAN BE USED WITH ANY 19" EIA STANDARD COMPONENT IN ADDITION TO ALL PANDUIT HORIZONTAL CABLE MANAGEMENT AND PATCH PANEL PRODUCTS.
- EIA UNIVERSAL STANDARD HOLE PROGRESSION ON EQUIPMENT RAILS 15.88mm [.625in], 15.88mm [.625in], 12.70mm [.5in], 15.88mm [.625in], 15.88mm [.625in], 12.7mm [.5in]...ETC.
- PARTS SUPPLIED:
  - BASE CABINET
  - FRONT PERFORATED SINGLE HINGE DOOR (SEE CHART ON SHEET 2)
  - REAR PERFORATED SPLIT DOOR (SEE CHART ON SHEET 2)
  - SPLIT SIDE PANELS (SEE CHART ON SHEET 2)
  - CAGE NUT UTILITY STYLE EQUIPMENT RAILS FRONT & REAR (SEE CHART ON SHEET 2)
  - CASTERS (SEE CHART ON SHEET 2)
  - CABLE MANAGEMENT FINGERS (SEE CHART ON SHEET 2)
  - CABINET HARDWARE KIT
  - INSTRUCTION SHEET
- RACK UNIT SPACING NUMERALS ARE CLEARLY PRINTED ON EQUIPMENT MOUNTING RAILS.
- FULLY BONDED STRUCTURE WHEN ASSEMBLED PER INSTRUCTIONS.
- STATIC LOAD RATING. 1360 Kg (3000 LBS)
- ROLLING LOAD RATING. 1133 Kg (2500 LBS)
- SINGLE POINT GROUND LOCATIONS AT TOP AND BOTTOM OF CABINET.
- ALL CABINET RAILS ARE INSTALLED NUMBERS UP.

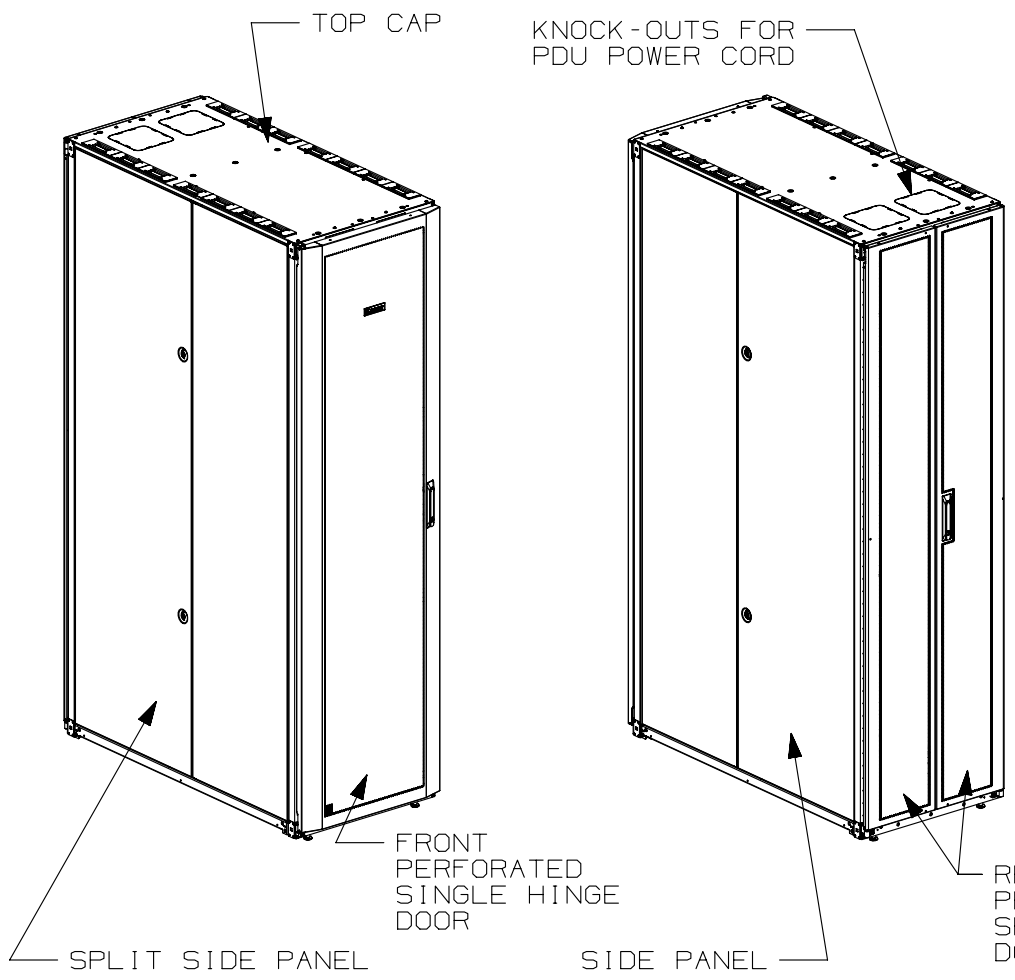

TITLE  
NET-ACCESS S TYPE UTILITY CABINET 600mm WIDE X 1200mm DEEP FAMILY A  
CUSTOMER DRAWING

ITEM REVISION NAME  
12V352BT/01.PRT  
DATASET FILE NAME  
12V352BT\_DC/01A.PRT



REV	DATE	BY	CHK	APR	DESCRIPTION	ECN
O1A	12-01-14	MDCA	ADP	TCN	FLOOR MOUNT DIMENSIONS UPDATED	V09000BX
00A	6-06-13	PBS	JDW	JDWE	RELEASED TO PRODUCTION	12V352BT-DC

MATERIAL:  
N/A  
DRAWING NUMBER:  
12V352BT-DC

THIRD ANGLE PROJECTION

DRAWN BY	DATE	CHK	SCALE	SHT 1 OF 5	SIZE
PBS	6-06-13	JDW	NONE		A

2

1

THIS COPY IS PROVIDED ON A RESTRICTED BASIS AND IS NOT TO BE USED IN ANY WAY DETRIMENTAL TO THE INTERESTS OF PANDUIT CORP.

PART NO.	DESCRIPTION	SINGLE HINGE FRONT DOOR	SPLIT REAR DOOR	SPLIT SIDE PANEL	ADJUSTABLE FRONT UTILITY E-RAILS	REAR CAGE NUT FINGER MGMT E-RAILS	STANDARD PDU BRACKETS	CASTERS	CABLE MGMT FINGERS	CABINET WEIGHT FULLY UNPACKAGED	CABINET WEIGHT SHIPPING WEIGHT
S6222*A	NET-ACCESS S-TYPE CABINET 600mm X 42RU X 1200mm DEEP	01	01	02	02	02	00	04	01	128 Kg/EACH 282 LBS/EACH	148 Kg/EACH 327 LBS/EACH
S6522*A	NET-ACCESS S-TYPE CABINET 600mm X 45RU X 1200mm DEEP	01	01	02	02	02	00	04	01	132 Kg/EACH 292 LBS/EACH	153 Kg/EACH 337 LBS/EACH
S6822*A	NET-ACCESS S-TYPE CABINET 600mm X 48RU X 1200mm DEEP	01	01	02	02	02	00	04	01	137 Kg/EACH 302 LBS/EACH	157 Kg/EACH 347 LBS/EACH
S6229*A	NET-ACCESS S-TYPE CABINET 600mm X 42RU X 1200mm DEEP	01	01	00	02	02	00	04	01	92 Kg/EACH 202 LBS/EACH	112 Kg/EACH 247 LBS/EACH
S6529*A	NET-ACCESS S-TYPE CABINET 600mm X 45RU X 1200mm DEEP	01	01	00	02	02	00	04	01	94 Kg/EACH 207 LBS/EACH	114 Kg/EACH 252 LBS/EACH
S6829*A	NET-ACCESS S-TYPE CABINET 600mm X 48RU X 1200mm DEEP	01	01	00	02	02	00	04	01	96 Kg/EACH 212 LBS/EACH	116 Kg/EACH 257 LBS/EACH

\* DENOTES COLOR  
 "B" = BLACK  
 "W" = WHITE

REV	DATE	BY	CHK	APR	DESCRIPTION	ECN
01A	12-01-14	MDCA	ADP	TCN	SEE SHEET 1 OF 5 FOR REVISIONS	V09000BX
00A	6-06-13	PBS	JDW	JDWE	SEE SHEET 1 OF 5 FOR REVISIONS	12V352BT-DC

TITLE		NET-ACCESS S TYPE UTILITY CABINET 600mm WIDE X 1200mm DEEP FAMILY			
		CUSTOMER DRAWING			
ITEM REVISION NAME		12V352BT/01.PRT		<b>PANDUIT</b>	
DATASET FILE NAME		12V352BT_DC/01A.PRT			
				MATERIAL:	
				N/A	
				DRAWING NUMBER:	
				12V352BT-DC	
DRAWN BY	DATE	CHK	SCALE		
PBS	6-06-13	JDW	NONE	SHT 2 OF 5	
				SIZE	
				A	

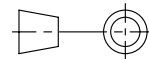

THIRD ANGLE PROJECTION

THIS COPY IS PROVIDED ON A RESTRICTED BASIS AND IS NOT TO BE USED IN ANY WAY DETRIMENTAL TO THE INTERESTS OF PANDUIT CORP.

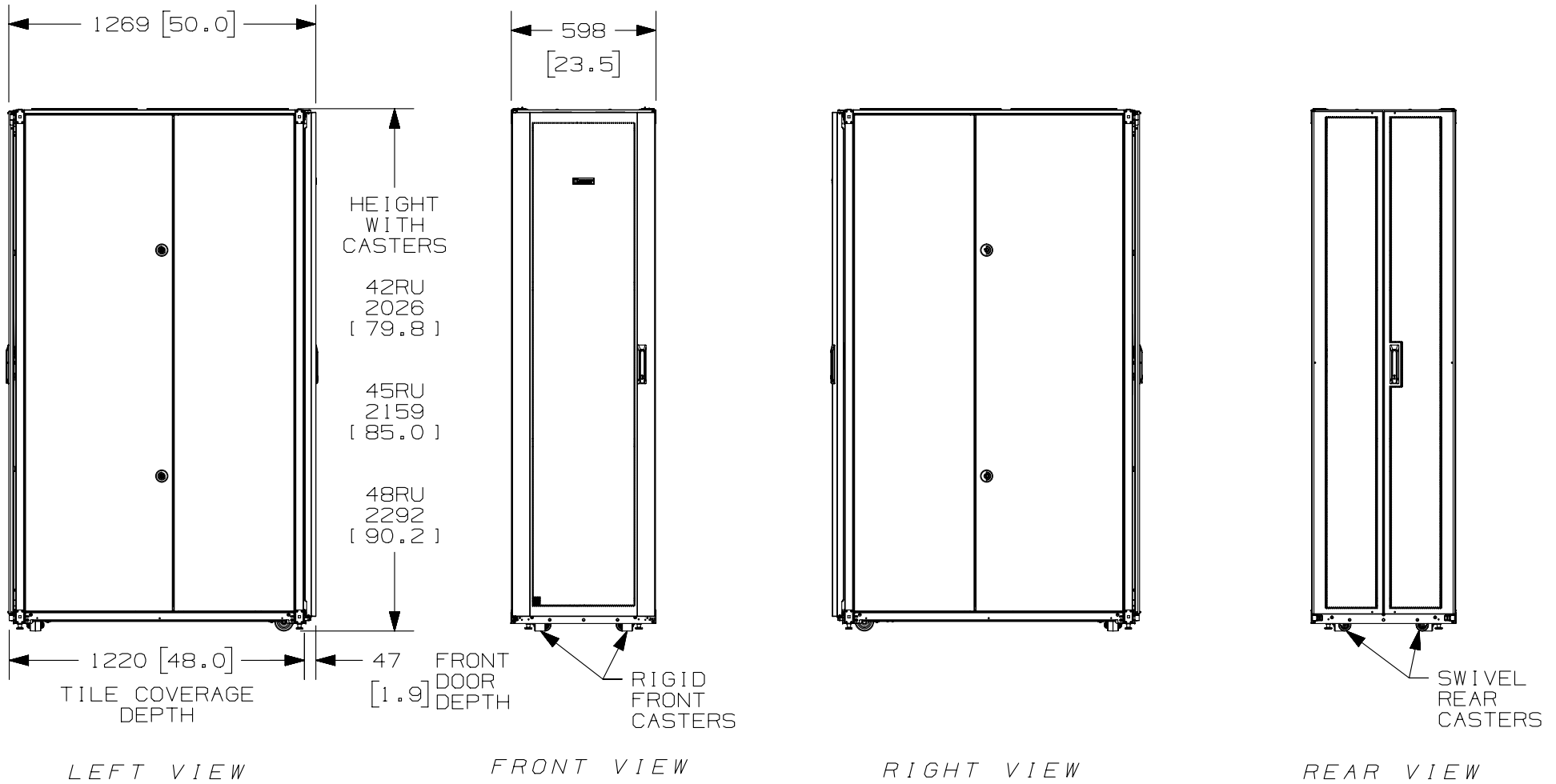

REV	DATE	BY	CHK	APR	DESCRIPTION	ECN
01A	12-01-14	MDCA	ADP	TCN	SEE SHEET 1 OF 5 FOR REVISIONS	V09000BX
00A	6-06-13	PBS	JDW	JDWE	SEE SHEET 1 OF 5 FOR REVISIONS	12V352BT-DC

TITLE		NET-ACCESS S TYPE UTILITY CABINET 600mm WIDE X 1200mm DEEP FAMILY	
		CUSTOMER DRAWING	
ITEM REVISION NAME		12V352BT/01.PRT	
DATASET FILE NAME		12V352BT_DC/01A.PRT	
MATERIAL:		N/A	
DRAWING NUMBER:		12V352BT-DC	
DRAWN BY	DATE	CHK	SCALE
PBS	6-06-13	JDW	NONE
SHT 3 OF 5		SIZE A	

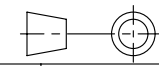

THIRD ANGLE PROJECTION

THIS COPY IS PROVIDED ON A RESTRICTED BASIS AND IS NOT TO BE USED IN ANY WAY DETRIMENTAL TO THE INTERESTS OF PANDUIT CORP.

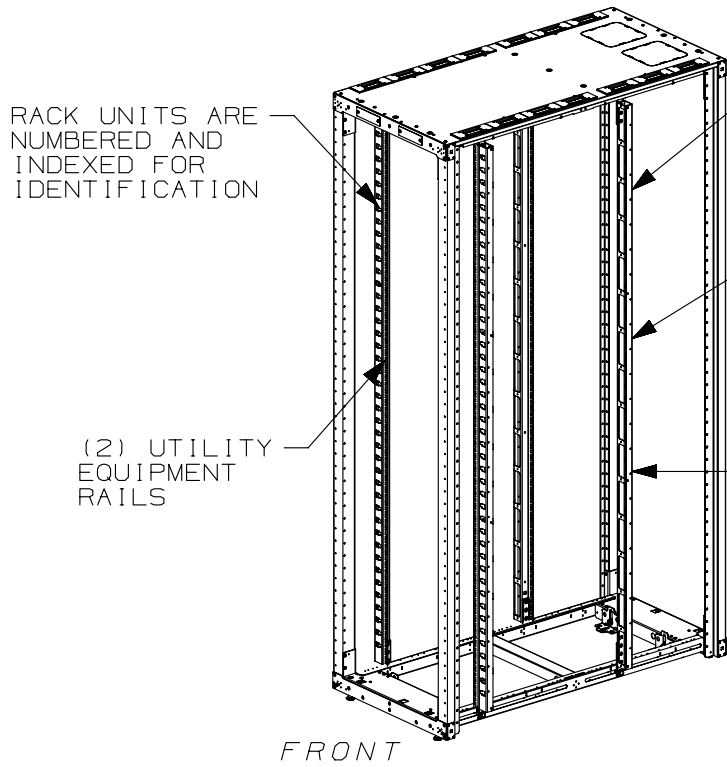

FRONT DOOR, REAR DOOR, AND SIDE PANELS NOT SHOWN

(9) LOCATIONS TAPPED FOR M10 THREADED ROD

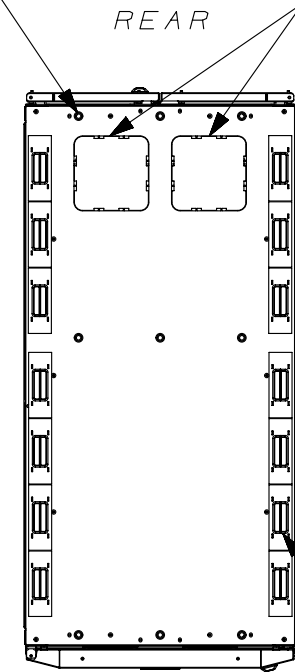

TOP VIEW

REV	DATE	BY	CHK	APR	DESCRIPTION	ECN
01A	12-01-14	MDCA	ADP	TCN	SEE SHEET 1 OF 5 FOR REVISIONS	V09000BX
00A	6-06-13	PBS	JDW	JDWE	SEE SHEET 1 OF 5 FOR REVISIONS	12V352BT-DC

TITLE		NET-ACCESS S TYPE UTILITY CABINET 600mm WIDE X 1200mm DEEP FAMILY	
		CUSTOMER DRAWING	
ITEM REVISION NAME		12V352BT/01.PRT	
DATASET FILE NAME		12V352BT_DC/01A.PRT	
MATERIAL:		N/A	
DRAWING NUMBER:		12V352BT-DC	
DRAWN BY	DATE	CHK	SCALE
PBS	6-06-13	JDW	NONE
THIRD ANGLE PROJECTION		SHT 4 OF 5	
SIZE		A	

THIS COPY IS PROVIDED ON A RESTRICTED BASIS AND IS NOT TO BE USED IN ANY WAY DETRIMENTAL TO THE INTERESTS OF PANDUIT CORP.

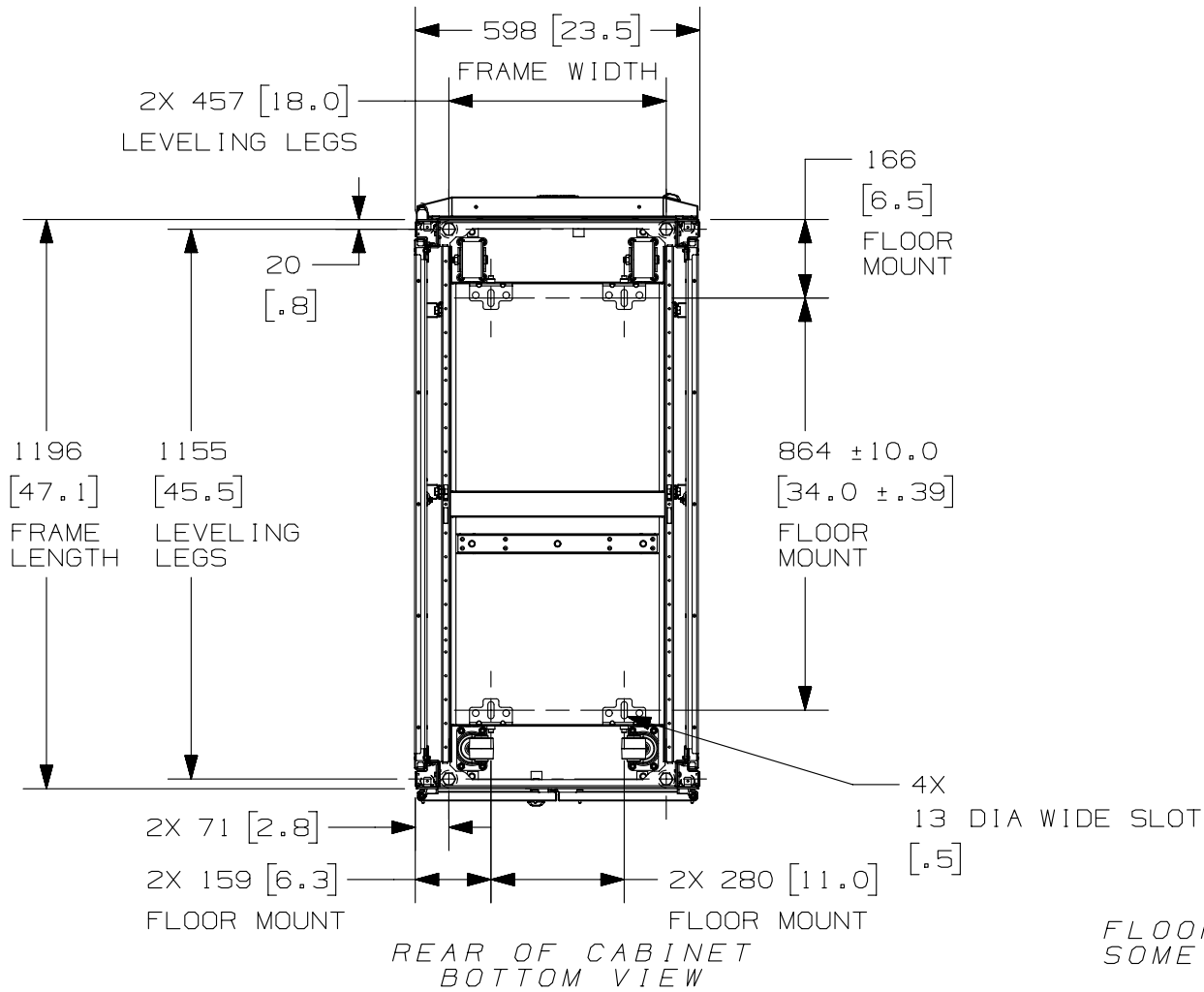

REV	DATE	BY	CHK	APR	DESCRIPTION	ECN
01A	12-01-14	MDCA	ADP	TCN	SEE SHEET 1 OF 5 FOR REVISIONS	V09000BX
00A	6-06-13	PBS	JDW	JDWE	SEE SHEET 1 OF 5 FOR REVISIONS	12V352BT-DC

TITLE		NET-ACCESS S TYPE UTILITY CABINET 600mm WIDE X 1200mm DEEP FAMILY		
		CUSTOMER DRAWING		
ITEM REVISION NAME		12V352BT/01.PRT		
DATASET FILE NAME		12V352BT_DC/01A.PRT		
		MATERIAL:		
		N/A		
		DRAWING NUMBER:		
		12V352BT-DC		
DRAWN BY	DATE	CHK	SCALE	SIZE
PBS	6-06-13	JDW	NONE	A

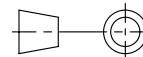

THIRD ANGLE  
PROJECTION



Компания «Life Electronics» занимается поставками электронных компонентов импортного и отечественного производства от производителей и со складов крупных дистрибьюторов Европы, Америки и Азии.

С конца 2013 года компания активно расширяет линейку поставок компонентов по направлению коаксиальный кабель, кварцевые генераторы и конденсаторы (керамические, пленочные, электролитические), за счёт заключения дистрибьюторских договоров

Мы предлагаем:

- Конкурентоспособные цены и скидки постоянным клиентам.
- Специальные условия для постоянных клиентов.
- Подбор аналогов.
- Поставку компонентов в любых объемах, удовлетворяющих вашим потребностям.
- Приемлемые сроки поставки, возможна ускоренная поставка.
- Доставку товара в любую точку России и стран СНГ.
- Комплексную поставку.
- Работу по проектам и поставку образцов.
- Формирование склада под заказчика.
- Сертификаты соответствия на поставляемую продукцию (по желанию клиента).
- Тестирование поставляемой продукции.
- Поставку компонентов, требующих военную и космическую приемку.
- Входной контроль качества.
- Наличие сертификата ISO.

В составе нашей компании организован Конструкторский отдел, призванный помогать разработчикам, и инженерам.

Конструкторский отдел помогает осуществить:

- Регистрацию проекта у производителя компонентов.
- Техническую поддержку проекта.
- Защиту от снятия компонента с производства.
- Оценку стоимости проекта по компонентам.
- Изготовление тестовой платы монтаж и пусконаладочные работы.



Тел: +7 (812) 336 43 04 (многоканальный)

Email: [org@lifeelectronics.ru](mailto:org@lifeelectronics.ru)