

VSC8662

Dual Port 10/100/1000BASE-T PHY and 100BASE-FX/1000BASE-X SerDes with Recovered Clock Outputs

GbE dual port PHY with recovered clock outputs delivers carrier-quality Synchronous Ethernet.

Helping OEMs to capitalize on the cost reduction and optimization of Synchronous Ethernet, the VSC8662 addresses the challenges in providing fully traceable timing across TDM backhaul links, cellular base stations, and other Synchronous Ethernet applications. With recovered clock outputs, the VSC8662 meets and goes beyond the requirements of the ITU-T recommendation G.8261/Y.1361. Supporting two copper/fiber ports and SGMII MAC interfaces, the VSC8662 includes a highly integrated feature set to ensure low-cost, rapid deployment.

Meeting the carrier demands for redundancy, the VSC8662 features dual recovered clocks to enable a primary and secondary timing reference. Programmable clock squelch control is included to inhibit undesirable clocks from propagating and to help prevent timing loops. VSC8662 is a compact GbE PHY providing clock recovery in combination with an SGMII interface, making layouts simpler than RGMII/GMII solutions. Also featured is a fast link failure identification to indicate the onset of a link failure in less than 1 ms, a critical feature for support of synchronization timing.

VSC8662 helps lower component count without sacrificing capabilities or utility, resulting in more cost-effective production and deployment. Its patented, low electromagnetic interference line driver and integrated line side termination resistors conserve both power and printed circuit board space. With an integrated two-wire serial multiplexer to control SFPs or power-over-Ethernet modules, VSC8662 also eliminates the need for an external two-wire serial device.

Microsemi's mixed signal and digital signal processing (DSP) architecture yield robust performance, supporting both full and half duplex 10BASE-T, 100BASE-TX, and 1000BASE-T over > 140 meters of Cat5, unshielded twisted pair cable, with industry leading tolerance to NEXT, FEXT, Echo, and system noise. With dual, high-performance 1.25 Gbps SerDes, VSC8662 maximizes receive jitter tolerance and minimizes transmit jitter in comparison to single SerDes architectures.

Applications

- Copper and fiber-based Synchronous Ethernet systems
- Wireless backhaul systems
- Carrier Ethernet cellular basestations

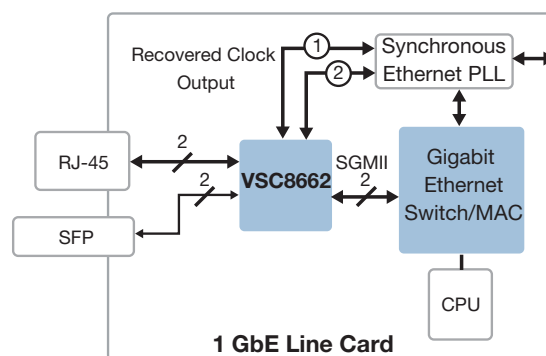

VSC8662

Dual Port 10/100/1000BASE-T PHY and 100BASE-FX/1000BASE-X SerDes with Recovered Clock Outputs

Synchronous Ethernet

- Recovered clock output support for G.8261 and IEEE-1588 Synchronous Ethernet applications, including programmable squelch control
- Patent-pending, fast link fail indication (< 1 ms) to provide an earlier indication of a link failure to critical metro Ethernet traffic and synchronization links

Advanced SerDes

- Dual, high-performance 1.25 Gbps SerDes to maximize receive jitter tolerance and minimize transmit jitter (in comparison to single SerDes architectures)
- Supports 100BASE-FX fiber, 1000BASE-X fiber, and triple-speed copper SFPs over SerDes pins
- Advanced SerDes feature capabilities including transmitter amplitude control, receiver equalization, and link integrity status information

Flexibility

- Integrated quad two-wire serial multiplexer to control SFPs or PoE modules, eliminating the need for an external two-wire serial device for the control and status of SFP or PoE modules
- VeriPHY® cable diagnostics suite provides extensive network cable information such as cable length, termination status, and open/short fault location
- Extensive test features (including near end, far end, connector loopback, and Ethernet packet generator with CRC error-counter) to decrease time-to-market

Wide Range of Support

- Compliant with IEEE 802.3 (10BASE-T, 100BASE-TX, 1000BASE-T, 100BASE-FX, and 1000BASE-X) specifications
- Support for 802.3ah unidirectional transport for 100BASE-FX and 1000BASE-X fiber media
- Support for > 16 kB jumbo frames in all speeds with programmable synchronization FIFOs
- Supports Cisco SGMII v1.7 and 1000BASE-X MACs, IEEE 1149.1 JTAG boundary scan, and IEEE 1149.6 AC-JTAG

Low Power

- Low power consumption with three power savings modes
- ActiPHY™ power management system with built-in intelligence and saving modes

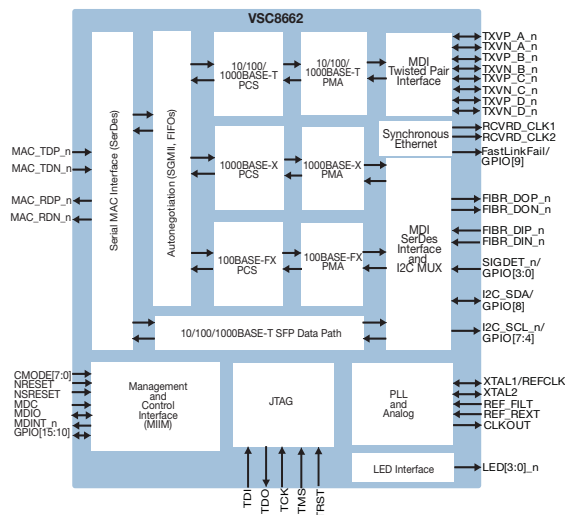

Microsemi

Microsemi Corporate Headquarters
 One Enterprise, Aliso Viejo, CA 92656 USA
 Within the USA: +1 (800) 713-4113
 Outside the USA: +1 (949) 380-6100
 Sales: +1 (949) 380-6136
 Fax: +1 (949) 215-4996
 email: sales.support@microsemi.com
 www.microsemi.com

Microsemi Corporation (Nasdaq: MSCC) offers a comprehensive portfolio of semiconductor and system solutions for communications, defense and security, aerospace, and industrial markets. Products include high-performance and radiation-hardened analog mixed-signal integrated circuits, FPGAs, SoCs, and ASICs; power management products; timing and synchronization devices and precise time solutions; voice processing devices; RF solutions; discrete components; enterprise storage and communications solutions, security technologies, and scalable anti-tamper products; Ethernet solutions; Power-over-Ethernet ICs and midspans; custom design capabilities and services. Microsemi is headquartered in Aliso Viejo, California, and has approximately 4,800 employees worldwide. Learn more at www.microsemi.com.

Компания «Life Electronics» занимается поставками электронных компонентов импортного и отечественного производства от производителей и со складов крупных дистрибьюторов Европы, Америки и Азии.

С конца 2013 года компания активно расширяет линейку поставок компонентов по направлению коаксиальный кабель, кварцевые генераторы и конденсаторы (керамические, пленочные, электролитические), за счёт заключения дистрибьюторских договоров

Мы предлагаем:

- Конкуренеспособные цены и скидки постоянным клиентам.
- Специальные условия для постоянных клиентов.
- Подбор аналогов.
- Поставку компонентов в любых объемах, удовлетворяющих вашим потребностям.
- Приемлемые сроки поставки, возможна ускоренная поставка.
- Доставку товара в любую точку России и стран СНГ.
- Комплексную поставку.
- Работу по проектам и поставку образцов.
- Формирование склада под заказчика.
- Сертификаты соответствия на поставляемую продукцию (по желанию клиента).
- Тестирование поставляемой продукции.
- Поставку компонентов, требующих военную и космическую приемку.
- Входной контроль качества.
- Наличие сертификата ISO.

В составе нашей компании организован Конструкторский отдел, призванный помогать разработчикам, и инженерам.

Конструкторский отдел помогает осуществить:

- Регистрацию проекта у производителя компонентов.
- Техническую поддержку проекта.
- Защиту от снятия компонента с производства.
- Оценку стоимости проекта по компонентам.
- Изготовление тестовой платы монтаж и пусконаладочные работы.



Тел: +7 (812) 336 43 04 (многоканальный)

Email: org@lifeelectronics.ru