

REVISIONS				
REV.	ECN/E-R	DESCRIPTION	DATE	APPROVED
B		CUSTOMER DRAWING	2006/04/05	J.SI
C		UPDATED	2006/08/09	
D		UPDATED	2007/01/02	

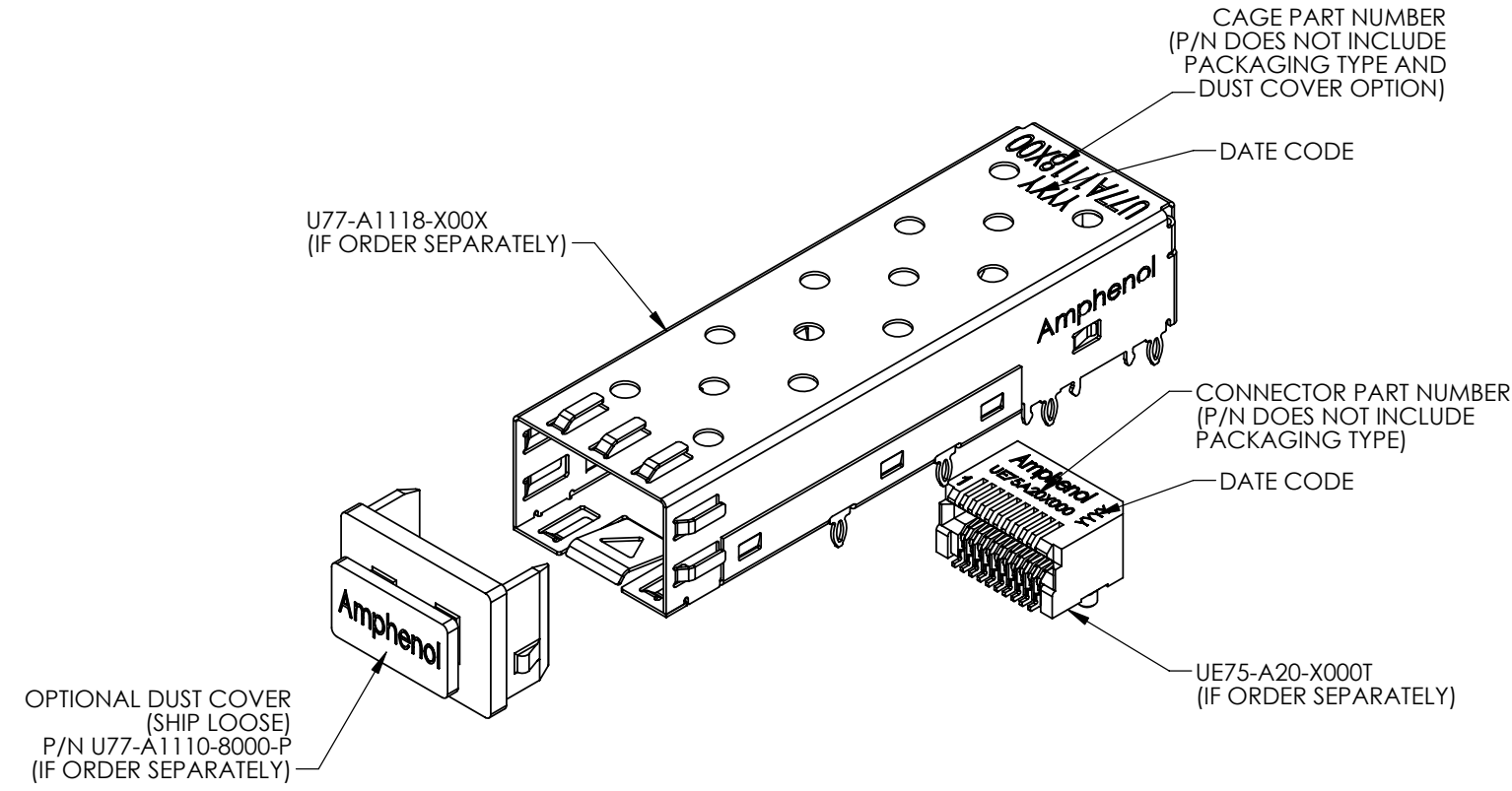

AMPHENOL PART NUMBER CONFIGURATION:

UE78 - A 1 1 1 8 - 0 X X X X

OPTIONAL DUST COVER
 0 - WITHOUT DUST COVER
 D - WITH DUST COVER (SHIP LOOSE)

PLATING OPTIONS FOR CONNECTOR
 2 - 30µ" GOLD PLATING ON MATING AREA
 GOLD FLASH ON TERMINATION
 3 - 30µ" GOLD PLATING ON MATING AREA
 150-300µ" MATTE TIN ON TERMINATION
 5 - 15µ" GOLD PLATING ON MATING AREA
 GOLD FLASH ON TERMINATION
 6 - 15µ" GOLD PLATING ON MATING AREA
 150-300µ" MATTE TIN ON TERMINATION

PACKAGING OPTIONS
 T - TAPE AND REEL PACKAGING
 FOR BOTH CONNECTORS AND
 CAGES
 H - TAPE AND REEL FOR
 CONNECTORS TRAY FOR
 CAGES

PLATING OPTIONS FOR CAGE
 1 - TIN
 2 - NICKEL

MATERIAL (RoHS COMPLIANCE):

CAGE:
 COPPER ALLOY
 PLATING OPTION 1: 100µ" [2.54 µm] TIN PLATING OVER
 50 µ" (1.27 µm) NICKEL UNDER PLATING.
 PLATING OPTION 2: 100µ" [2.54 µm] NICKEL PLATING
 (NOT FOR SOLDER PINS).
DUST COVER
 THERMOPLASTIC, COLOR BLACK.
PACKAGING:
 TAPE AND REEL OR TRAY PACKAGING.
 TEMPERATURE RANGE: -40 °C TO +85 °C

CONNECTOR:

PLASTIC HOUSING:
 HIGH TEMPERATURE RESISTANT NYLON FLAMMABILITY RATING UL94V-0.
CONTACTS:
 PHOSPHOR BRONZE
 PLATING OPTION 2: 30µ" [0.76 µm] GOLD ON MATING AREA AND 2 µ"
 (0.05 µm) GOLD FLASH PLATING ON TERMINATION OVER
 50µ"[1.27µm] NICKEL UNDER LAYER.
 PLATING OPTION 3: 30µ" [0.76 µm] GOLD ON MATING AREA AND
 150-300 µ" (3.81-7.62 µm) LOW WHISKER MATTE TIN PLATING
 ON TERMINATION OVER 50µ" [1.27 µm] NICKEL UNDER LAYER.
 PLATING OPTION 5: 15µ" GOLD PLATING ON MATING AREA
 GOLD FLASH ON TERMINATION
 PLATING OPTION 6: 15µ" GOLD PLATING ON MATING AREA
 150-300µ" (3.81-7.62 µm) MATTE TIN ON TERMINATION
PACKAGING:
 TAPE AND REEL.
 TEMPERATURE RANGE: -40 °C TO +85 °C

DO NOT SCALE DRAWING

THIS DOCUMENT CONTAINS PROPRIETARY INFORMATION AND SUCH INFORMATION MAY NOT BE DISCLOSED TO OTHERS FOR ANY PURPOSE OR USED FOR MANUFACTURING PUPOSES WITHOUT PERMISSION FROM AMPHENOL CANADA CORP.

APPROVALS		DATE	Amphenol Canada Corp.		
DRAWN	A.LIU	2006/02/13			
DESIGNED	J.SI	2006/02/13	TITLE SFP CAGE + CONNECTOR 1X1 8 PRESS FIT / 12 EMI PINS		
CHECKED	J.SI	2006/02/13			
QA APPD	X	X			
IE APPD	X	X	SIZE A3	DWG. NO. P-UE78-A1118-0XXXX	REV. D
DWG APPD			SCALE 2:1	PROJECT	SHEET 1 OF 7

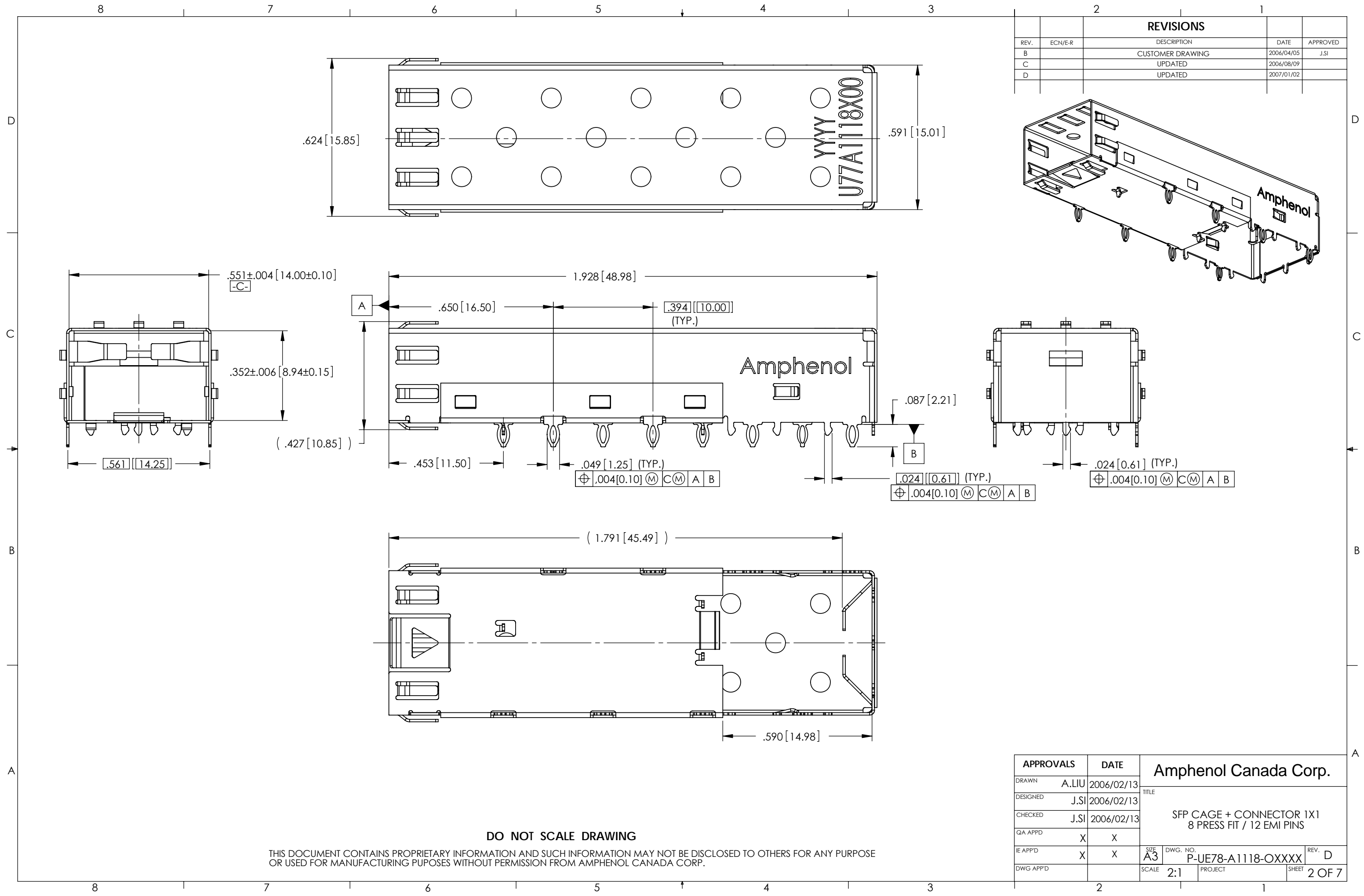

REVISIONS				
REV.	ECN/E-R	DESCRIPTION	DATE	APPROVED
B		CUSTOMER DRAWING	2006/04/05	J.SI
C		UPDATED	2006/08/09	
D		UPDATED	2007/01/02	

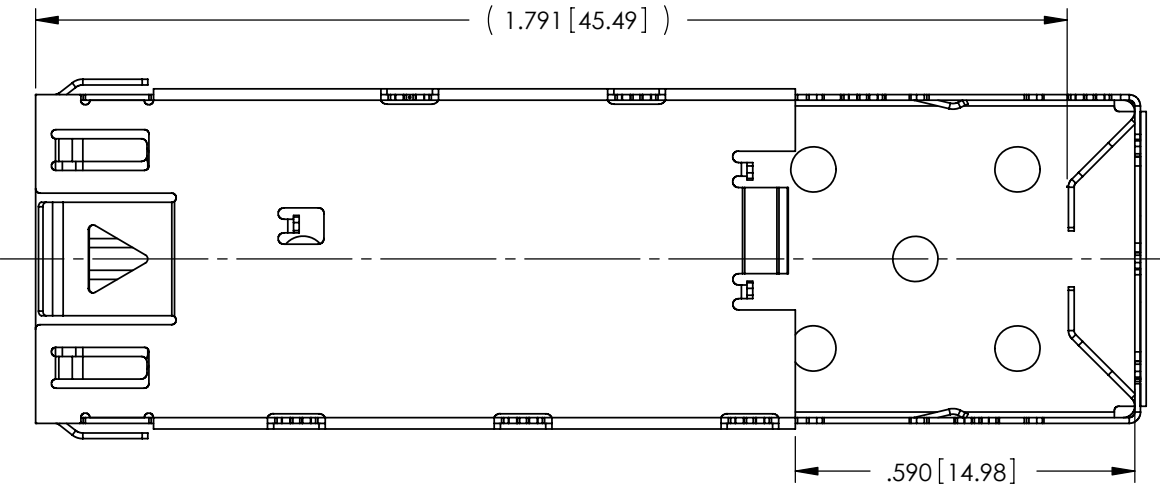
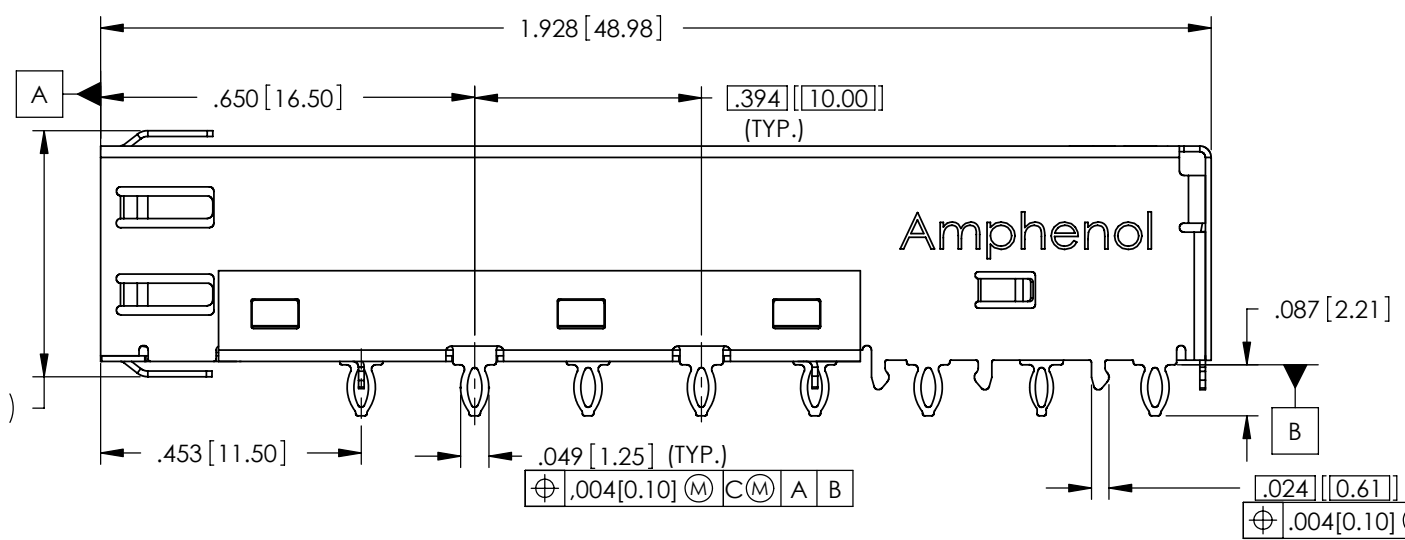
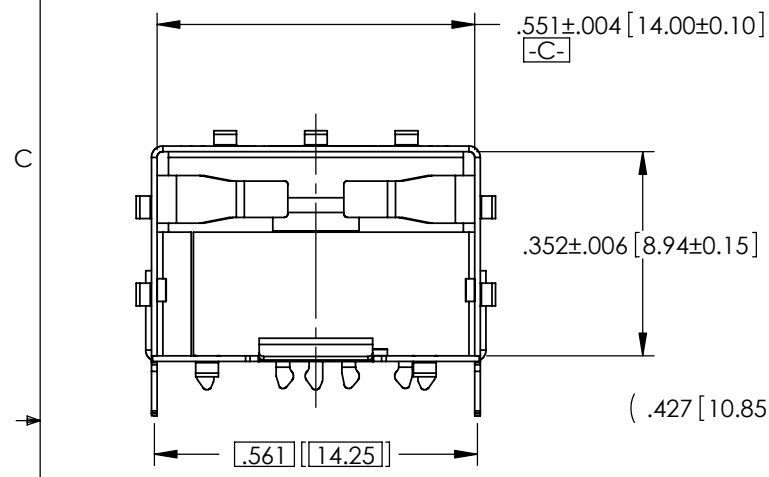
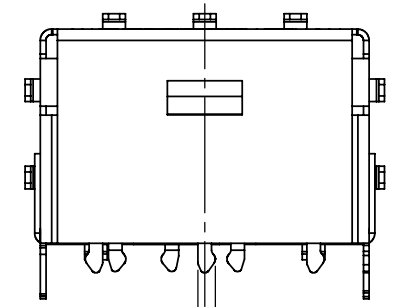
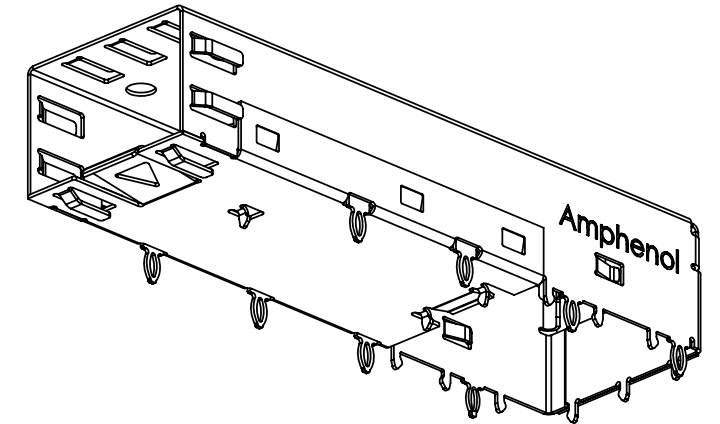

DO NOT SCALE DRAWING

THIS DOCUMENT CONTAINS PROPRIETARY INFORMATION AND SUCH INFORMATION MAY NOT BE DISCLOSED TO OTHERS FOR ANY PURPOSE OR USED FOR MANUFACTURING PUPOSES WITHOUT PERMISSION FROM AMPHENOL CANADA CORP.

APPROVALS		DATE	Amphenol Canada Corp.		
DRAWN	A.LIU	2006/02/13	TITLE		
DESIGNED	J.SI	2006/02/13	SFP CAGE + CONNECTOR 1X1 8 PRESS FIT / 12 EMI PINS		
CHECKED	J.SI	2006/02/13	REV. D		
QA APPD	X	X	SIZE	DWG. NO.	REV.
IE APPD	X	X	A3	P-UE78-A1118-OXXXX	D
DWG APPD			SCALE	PROJECT	SHEET
			2:1		2 OF 7

REVISIONS				
REV.	ECN/E-R	DESCRIPTION	DATE	APPROVED
B		CUSTOMER DRAWING	2006/04/05	J.SI
C		UPDATED	2006/08/09	
D		UPDATED	2007/01/02	

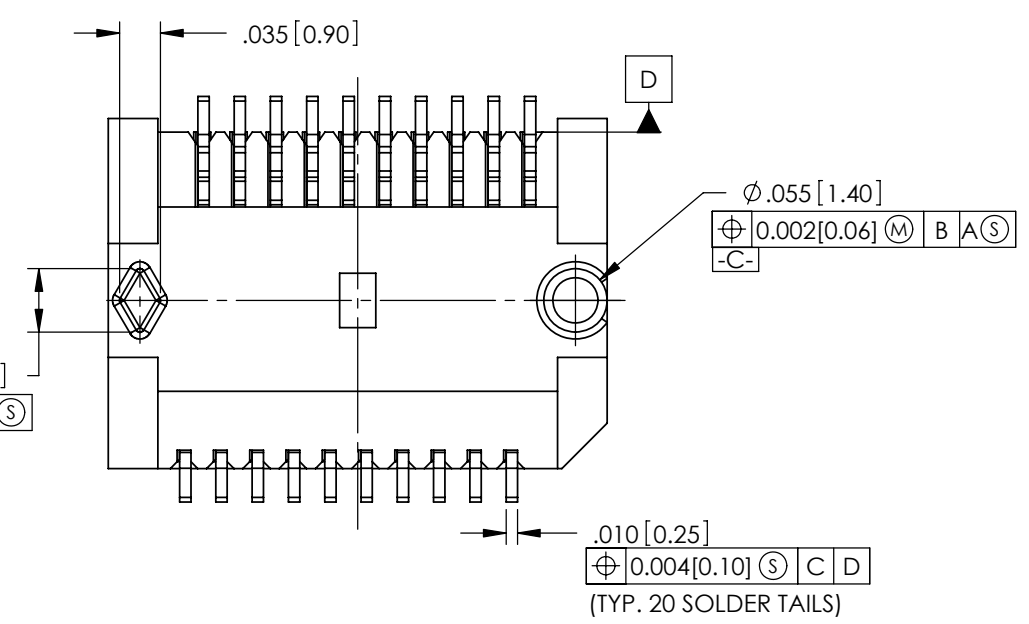
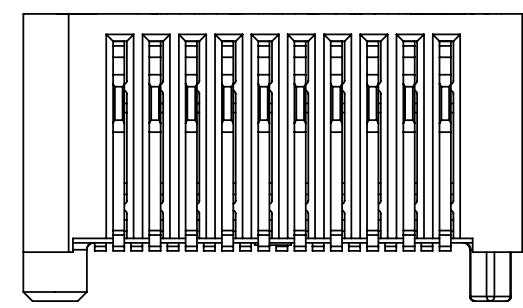
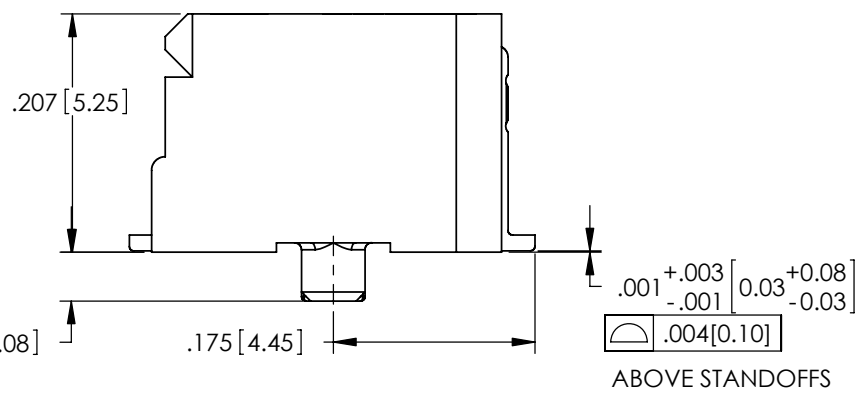
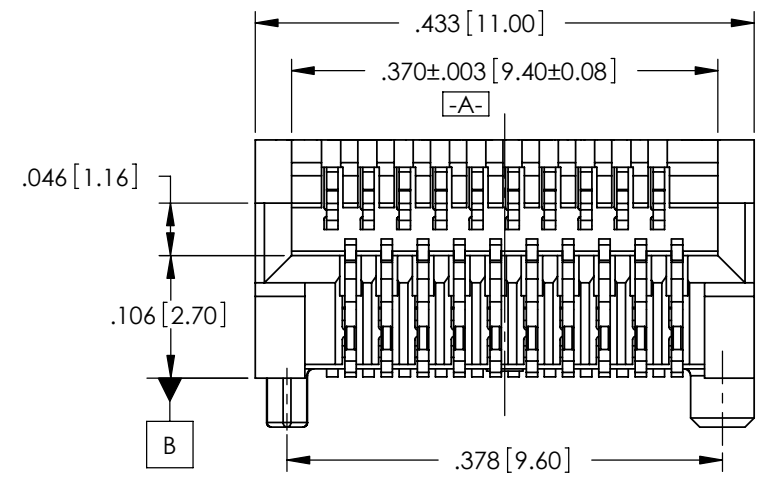
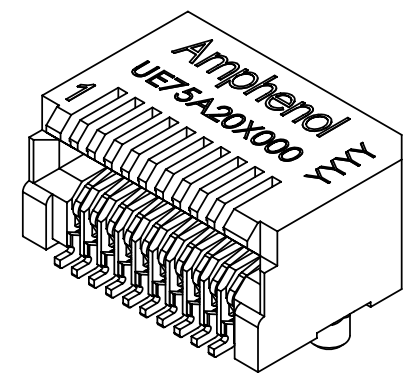
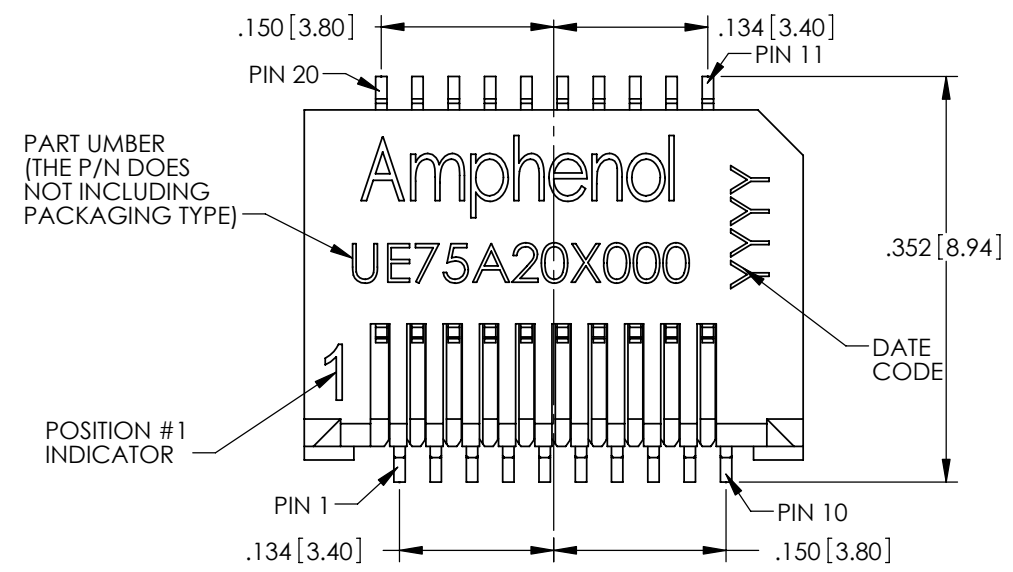

$\varnothing 0.002 [0.06] (M) B A(S) C(S)$

$\varnothing 0.004 [0.10] (S) C D$
(TYP. 20 SOLDER TAILS)

DO NOT SCALE DRAWING

THIS DOCUMENT CONTAINS PROPRIETARY INFORMATION AND SUCH INFORMATION MAY NOT BE DISCLOSED TO OTHERS FOR ANY PURPOSE OR USED FOR MANUFACTURING PURPOSES WITHOUT PERMISSION FROM AMPHENOL CANADA CORP.

APPROVALS		DATE	Amphenol Canada Corp.		
DRAWN	A.LIU	2006/02/13	TITLE		
DESIGNED	J.SI	2006/02/13	SFP CAGE + CONNECTOR 1X1 8 PRESS FIT / 12 EMI PINS		
CHECKED	J.SI	2006/02/13			
QA APPD	X	X			
IE APPD	X	X	SIZE A3	DWG. NO. P-UE78-A1118-0XXXX	REV. D
DWG APPD			SCALE 4:1	PROJECT	SHEET 3 OF 7

REVISIONS				
REV.	ECN/E-R	DESCRIPTION	DATE	APPROVED
B		CUSTOMER DRAWING	2006/04/05	
C		UPDATED	2006/08/09	
D		UPDATED	2007/01/02	

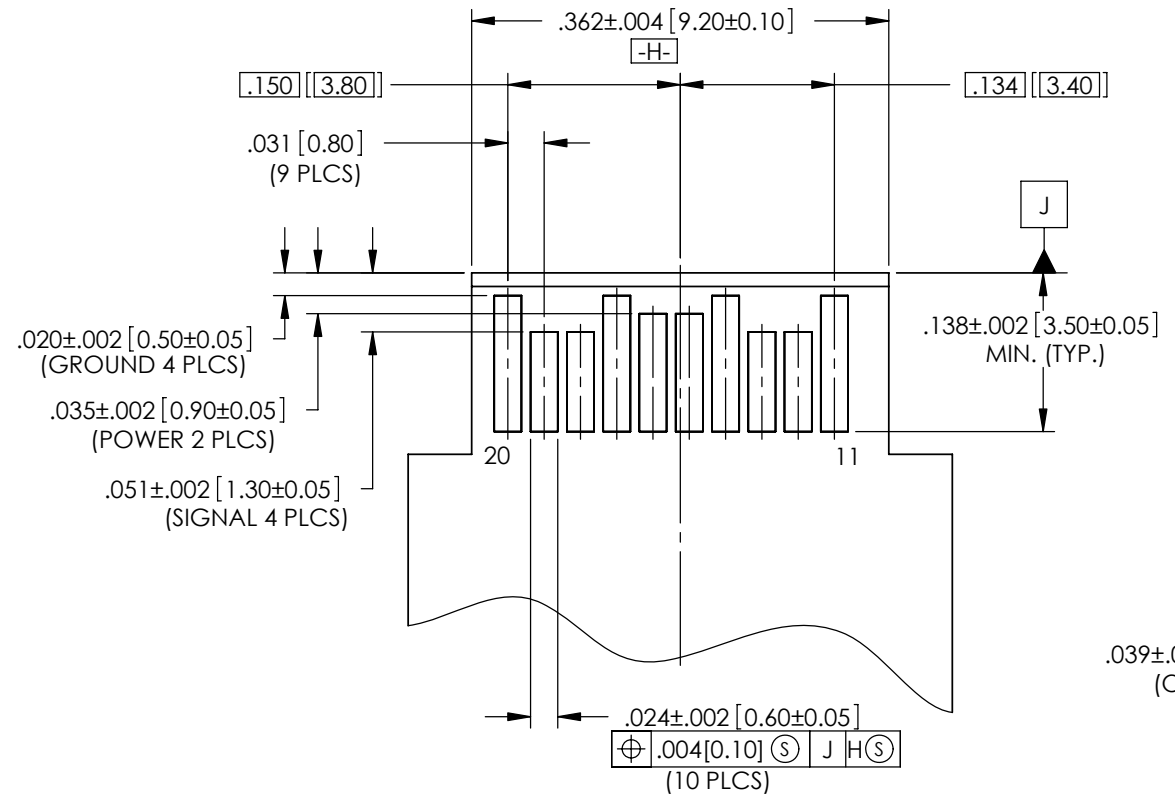

TOP VIEW OF BOAD

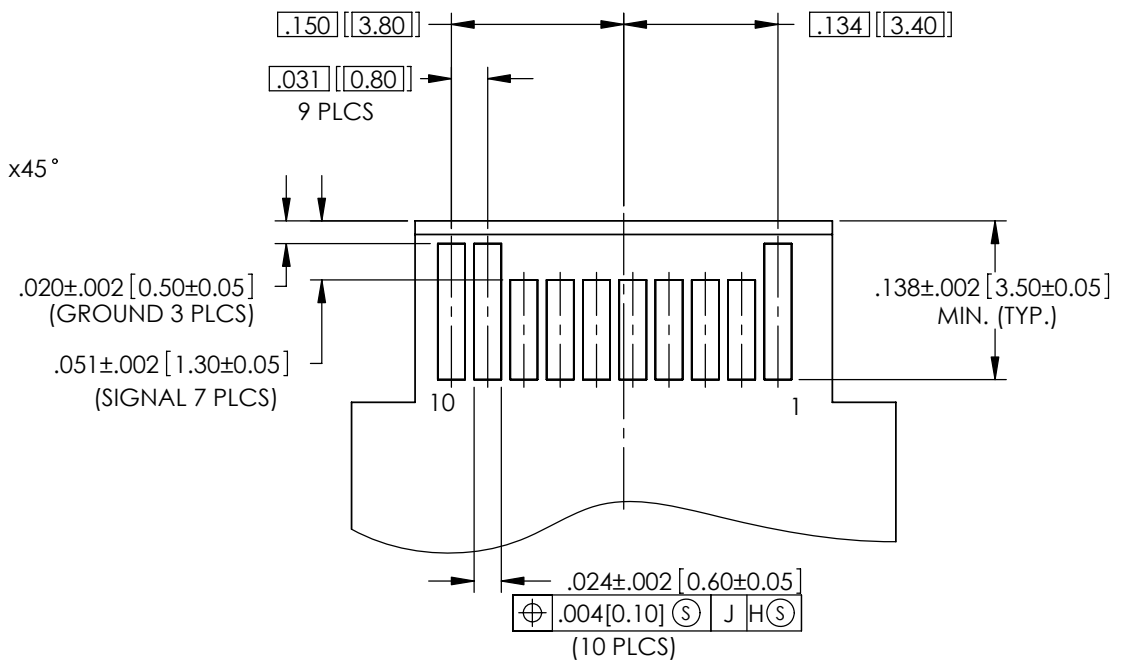
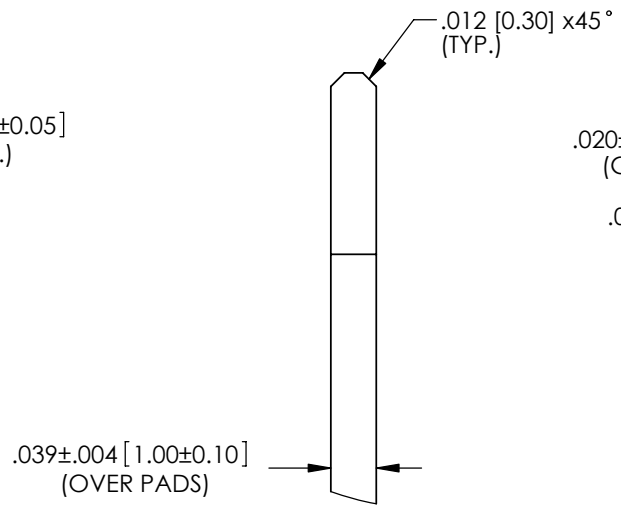

BOTTOM VIEW OF BOAD

RECOMMENDED LAYOUT DETAIL
MATING TRANSCEIVER PCB

DO NOT SCALE DRAWING

THIS DOCUMENT CONTAINS PROPRIETARY INFORMATION AND SUCH INFORMATION MAY NOT BE DISCLOSED TO OTHERS FOR ANY PURPOSE OR USED FOR MANUFACTURING PUPOSES WITHOUT PERMISSION FROM AMPHENOL CANADA CORP.

APPROVALS		DATE	Amphenol Canada Corp.		
DRAWN	A.LIU	2006/02/13	TITLE SFP CAGE + CONNECTOR 1X1 8 PRESS FIT / 12 EMI PINS		
DESIGNED	J.SI	2006/02/13			
CHECKED	J.SI	2006/02/13			
QA APPD	X	X			
IE APPD	X	X	SIZE A3	DWG. NO. P-UE78-A1118-0XXXX	REV. D
DWG APPD			SCALE 4:1	PROJECT	SHEET 4 OF 7

REVISIONS

REV.	ECN/E-R	DESCRIPTION	DATE	APPROVED
B		CUSTOMER DRAWING	2006/04/05	J.SI
C		UPDATED	2006/08/09	
D		UPDATED	2007/01/02	

NOTES;
 1. DATUM AND BASIC DIMENTIONS ESTABLISHED BY CUSTOMER
 2. PADS AND VIAS ARE CHASSIS GROUND, 11 PLACES.
 3. THROUGH HOLES, PLATING OPTIONAL.

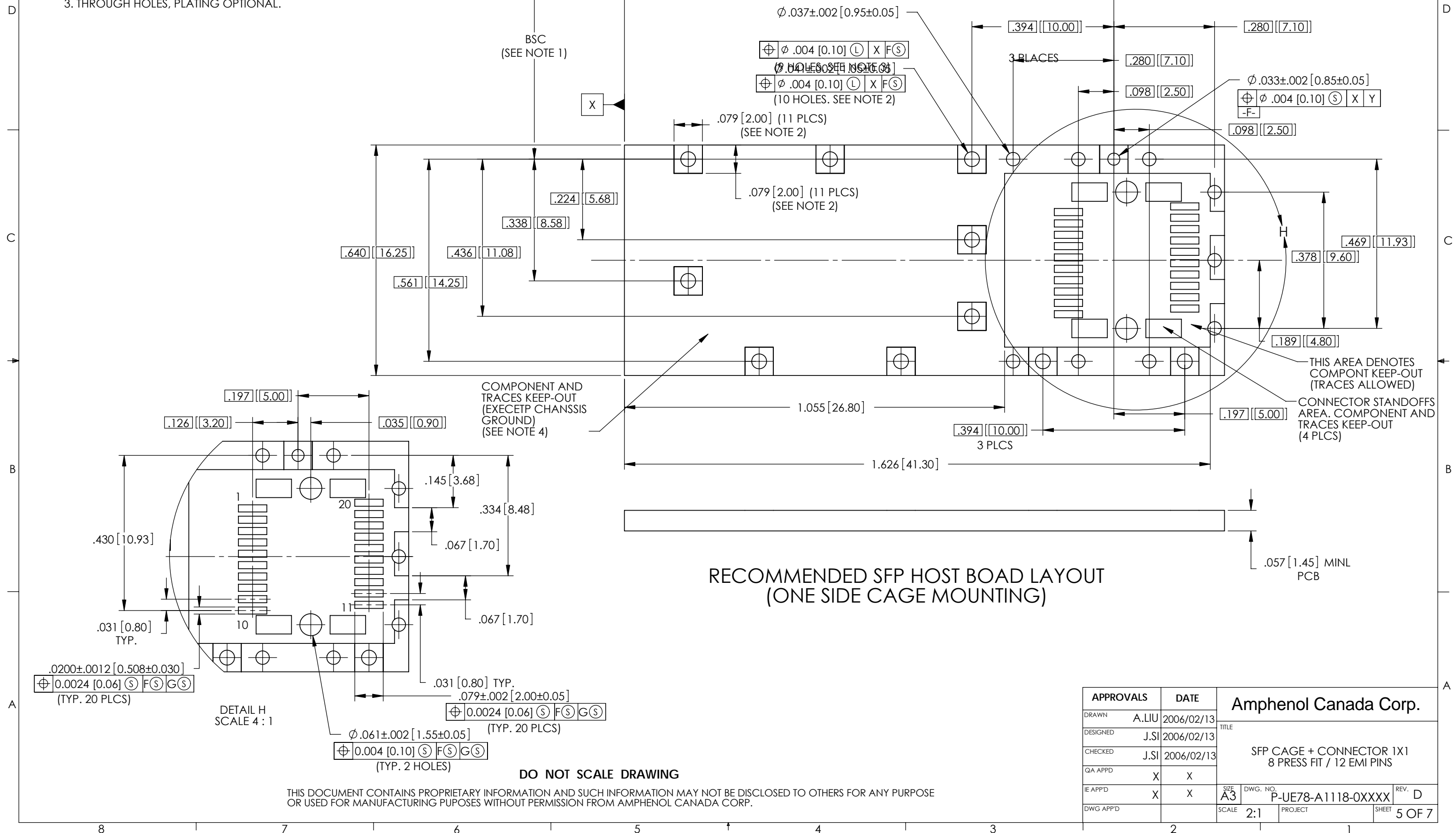

APPROVALS		DATE	Amphenol Canada Corp.	
DRAWN	A.LIU	2006/02/13	TITLE	
DESIGNED	J.SI	2006/02/13	SFP CAGE + CONNECTOR 1X1 8 PRESS FIT / 12 EMI PINS	
CHECKED	J.SI	2006/02/13	SIZE	DWG. NO.
QA APPD	X	X	A3	P-UE78-A1118-0XXXX
IE APPD	X	X	SCALE	PROJECT
DWG APPD			2:1	SHEET
				5 OF 7

REVISIONS				
REV.	ECN/E-R	DESCRIPTION	DATE	APPROVED
B		CUSTOMER DRAWING	2006/04/05	J.SI
C		UPDATED	2006/08/09	
D		UPDATED	2007/01/02	

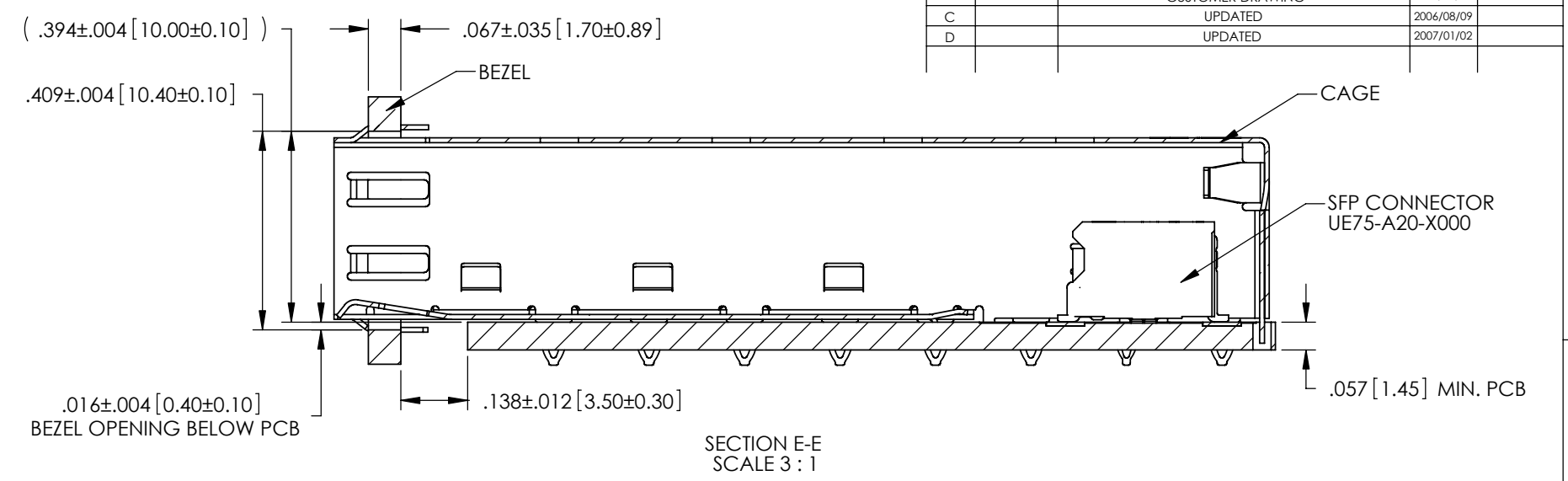
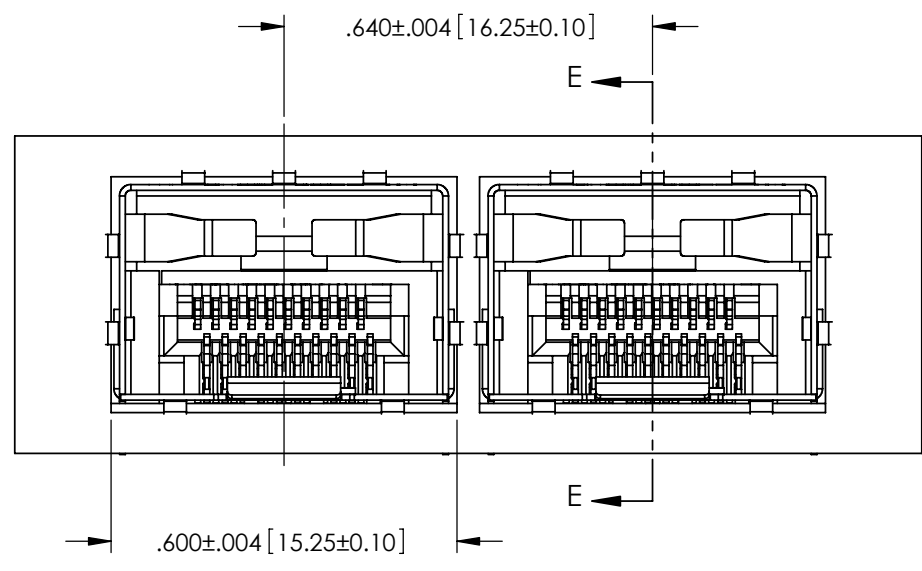

RECOMMENDED BEZEL DESIGN
(ONE SIDE CAGE MOUNTING)

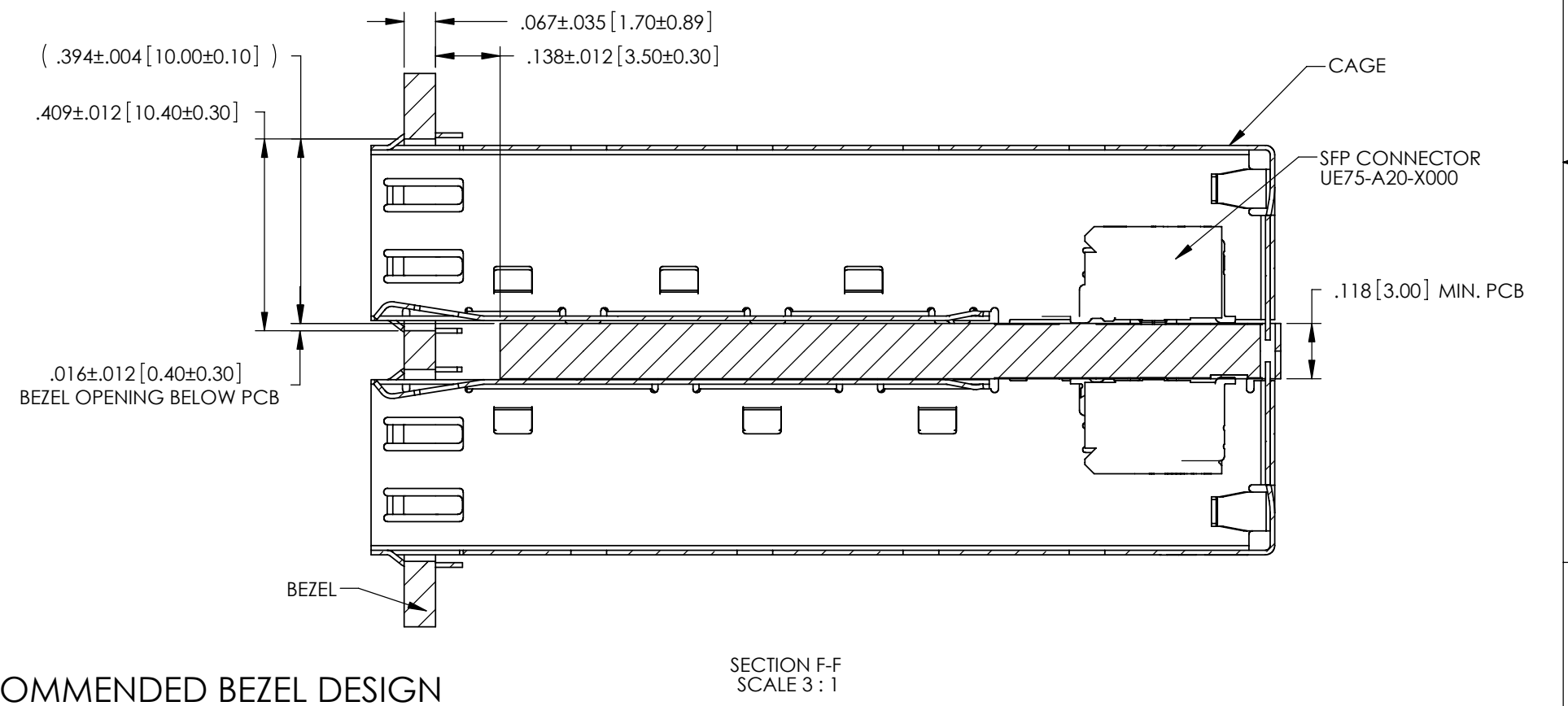
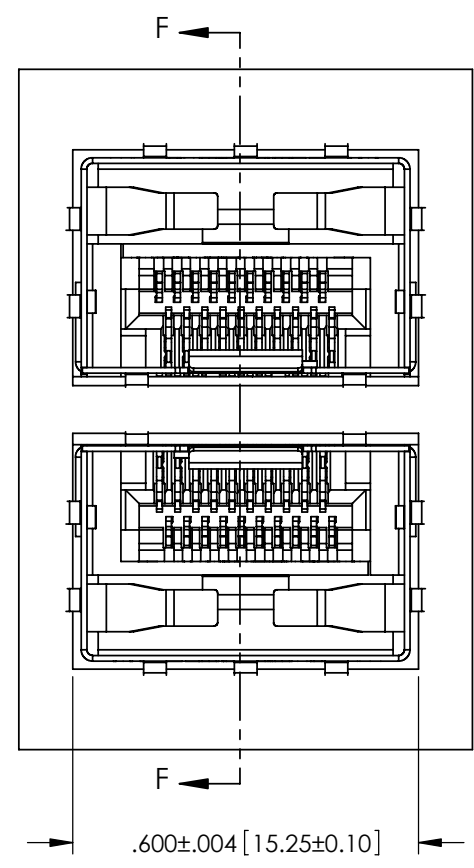

RECOMMENDED BEZEL DESIGN
(BELLY TO BELLY CAGE MOUNTING)

DO NOT SCALE DRAWING

THIS DOCUMENT CONTAINS PROPRIETARY INFORMATION AND SUCH INFORMATION MAY NOT BE DISCLOSED TO OTHERS FOR ANY PURPOSE OR USED FOR MANUFACTURING PUPOSES WITHOUT PERMISSION FROM AMPHENOL CANADA CORP.

APPROVALS		DATE	Amphenol Canada Corp.	
DRAWN	A.LIU	2006/02/13	TITLE	
DESIGNED	J.SI	2006/02/13	SFP CAGE + CONNECTOR 1X1 8 PRESS FIT / 12 EMI PINS	
CHECKED	J.SI	2006/02/13	REV. D	
QA APPD	X	X	SIZE A3	DWG. NO. P-UE78-A1118-0XXXX
IE APPD	X	X	SCALE 2:1	PROJECT
DWG APPD			SHEET 6 OF 7	

REVISIONS				
REV.	ECN/E-R	DESCRIPTION	DATE	APPROVED
B		CUSTOMER DRAWING	2006/04/05	
C		UPDATED	2006/08/09	
D		UPDATED	2007/01/02	

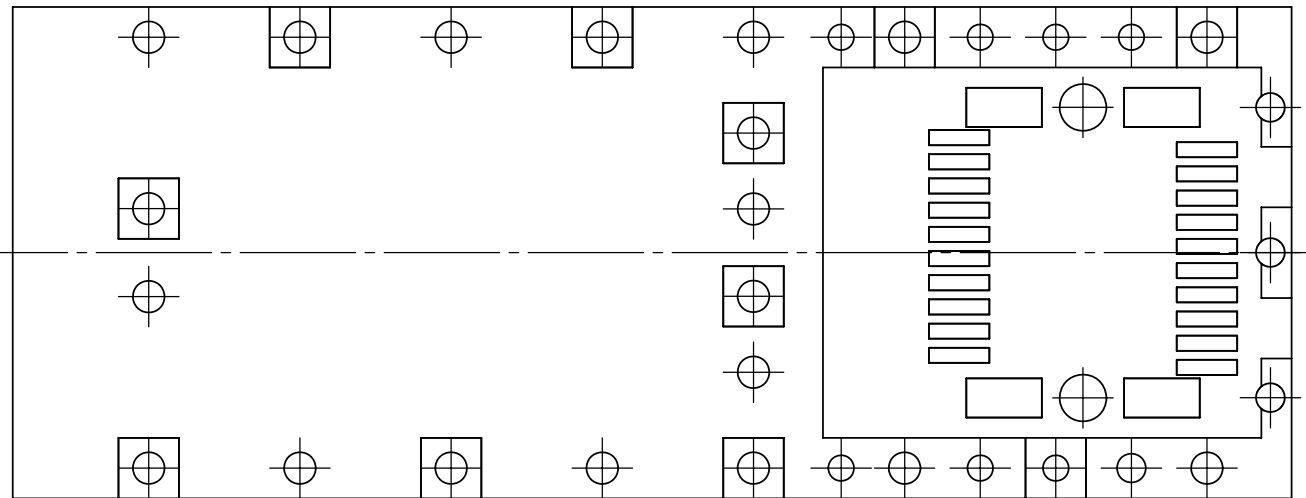
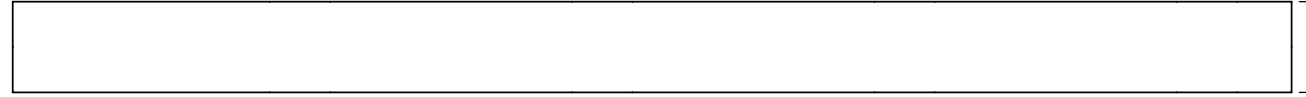
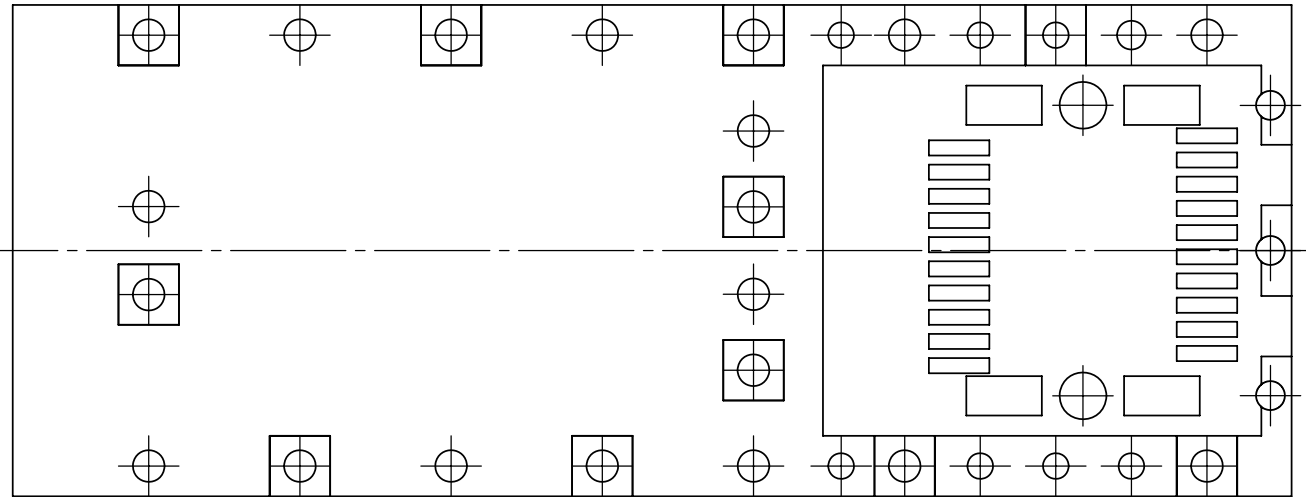

RECOMMENDED SFP HOST BOARD LAYOUT
(BELLY TO BELLY CAGE MOUNTING)

DO NOT SCALE DRAWING

THIS DOCUMENT CONTAINS PROPRIETARY INFORMATION AND SUCH INFORMATION MAY NOT BE DISCLOSED TO OTHERS FOR ANY PURPOSE OR USED FOR MANUFACTURING PUPOSES WITHOUT PERMISSION FROM AMPHENOL CANADA CORP.

APPROVALS		DATE	Amphenol Canada Corp.		
DRAWN	A.LIU	2006/02/13	TITLE SFP CAGE + CONNECTOR 1X1 8 PRESS FIT / 12 EMI PINS		
DESIGNED	J.SI	2006/02/13			
CHECKED	J.SI	2006/02/13			
QA APPD	X	X	SIZE A3	DWG. NO. P-UE78-A1118-0XXXX	REV. D
IE APPD	X	X	SCALE 2:1	PROJECT	SHEET 7 OF 7
DWG APPD					

Компания «Life Electronics» занимается поставками электронных компонентов импортного и отечественного производства от производителей и со складов крупных дистрибьюторов Европы, Америки и Азии.

С конца 2013 года компания активно расширяет линейку поставок компонентов по направлению коаксиальный кабель, кварцевые генераторы и конденсаторы (керамические, пленочные, электролитические), за счёт заключения дистрибьюторских договоров

Мы предлагаем:

- Конкурентоспособные цены и скидки постоянным клиентам.
- Специальные условия для постоянных клиентов.
- Подбор аналогов.
- Поставку компонентов в любых объемах, удовлетворяющих вашим потребностям.
- Приемлемые сроки поставки, возможна ускоренная поставка.
- Доставку товара в любую точку России и стран СНГ.
- Комплексную поставку.
- Работу по проектам и поставку образцов.
- Формирование склада под заказчика.
- Сертификаты соответствия на поставляемую продукцию (по желанию клиента).
- Тестирование поставляемой продукции.
- Поставку компонентов, требующих военную и космическую приемку.
- Входной контроль качества.
- Наличие сертификата ISO.

В составе нашей компании организован Конструкторский отдел, призванный помогать разработчикам, и инженерам.

Конструкторский отдел помогает осуществить:

- Регистрацию проекта у производителя компонентов.
- Техническую поддержку проекта.
- Защиту от снятия компонента с производства.
- Оценку стоимости проекта по компонентам.
- Изготовление тестовой платы монтаж и пусконаладочные работы.



Тел: +7 (812) 336 43 04 (многоканальный)

Email: org@lifeelectronics.ru