

# MMA685x, Single-axis, SPI Inertial Sensor

MMA685x, a SafeAssure solution, is a SPI-based, single-axis, medium-g, over-damped lateral accelerometer designed for use in automotive airbag systems.

## Features

- $\pm 20\text{ g}$  to  $\pm 120\text{ g}$  full-scale range
- 3.3 V or 5 V single supply operation
- SPI-compatible serial interface
- 10-bit digital signed or unsigned SPI data output
- Programmable arming functions
- 12 low-pass filter options, ranging from 50 Hz to 1000 Hz
- Optional offset cancellation with  $> 6\text{ s}$  averaging period and  $< 0.25\text{ LSB/s}$  slew rate
- Pb-free, 16-Pin QFN, 6 mm x 6 mm x 1.98 mm package

## Referenced Documents

- AEC-Q100, Revision G, dated May 14, 2007 (<http://www.aecouncil.com/>)

### Ordering information

Device	Axis	Axis Range	Package	Shipping
MMA6851BKCW	X	$\pm 25\text{ g}$	98ASA00690D	Tubes
MMA6853BKCW	X	$\pm 50\text{ g}$	98ASA00690D	Tubes
MMA6855BKCW	X	$\pm 120\text{ g}$	98ASA00690D	Tubes
MMA6856BKCW	X	$\pm 60\text{ g}$	98ASA00690D	Tubes
MMA6851BKCWR2	X	$\pm 25\text{ g}$	98ASA00690D	Tape & Reel
MMA6853BKCWR2	X	$\pm 50\text{ g}$	98ASA00690D	Tape & Reel
MMA6855BKCWR2	X	$\pm 120\text{ g}$	98ASA00690D	Tape & Reel
MMA6856BKCWR2	X	$\pm 60\text{ g}$	98ASA00690D	Tape & Reel

## MMA685x

### Bottom View

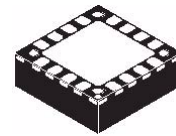

**Pb-free 16-Pin QFN**  
**6 mm x 6 mm x 1.98 mm package**

### Top View

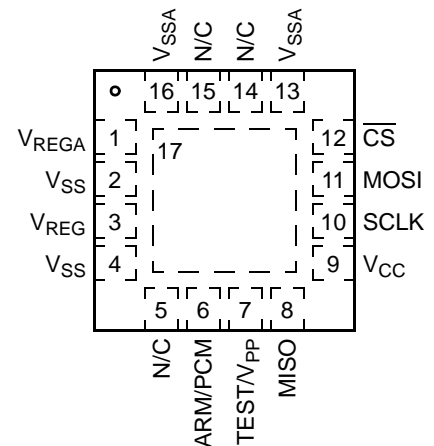

**Pin connections**

# 1 General Description

## 1.1 Application Diagram

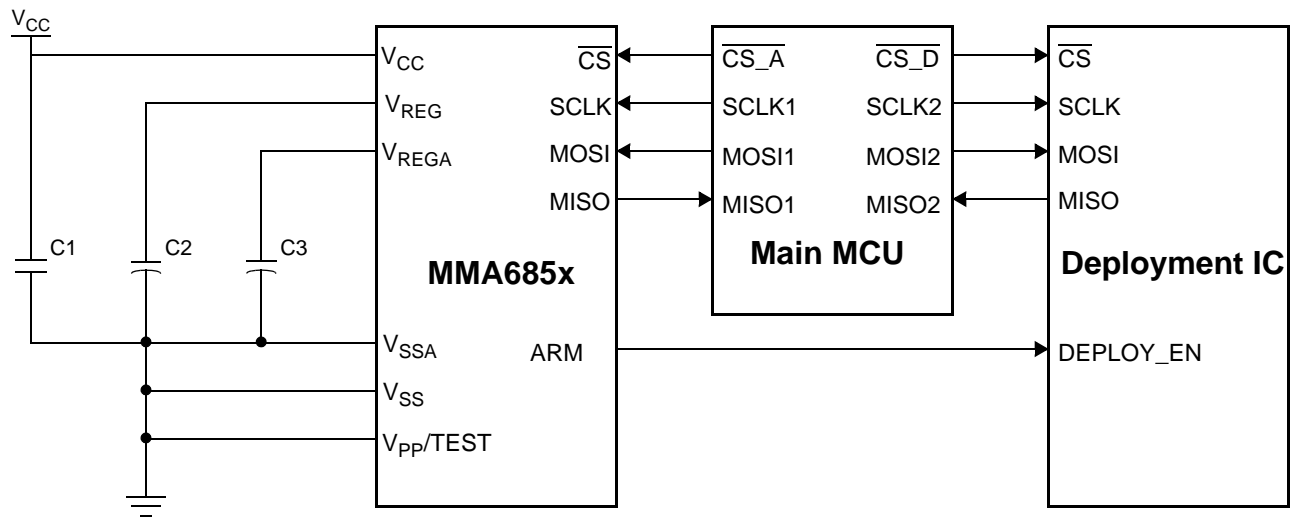

Figure 1. Application Diagram

Table 1. External Component Recommendations

Ref Des	Type	Description	Purpose
C1	Ceramic	0.1 $\mu$ F, 10 %, 10 V Minimum, X7R	$V_{CC}$ Power Supply Decoupling
C2	Ceramic	1 $\mu$ F, 10 %, 10 V Minimum, X7R	Voltage Regulator Output Capacitor ( $C_{REG}$ )
C3	Ceramic	1 $\mu$ F, 10 %, 10 V Minimum, X7R	Voltage Regulator Output Capacitor ( $C_{REGA}$ )

## 1.2 Device Orientation

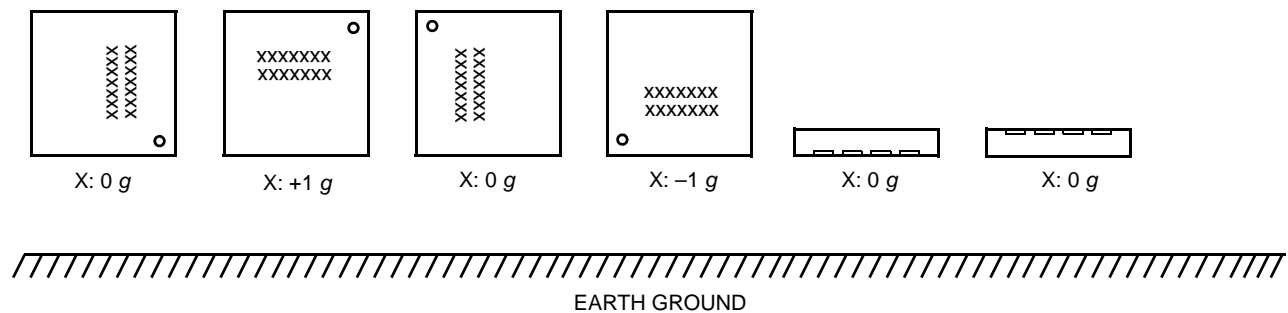

Figure 2. Device Orientation Diagram

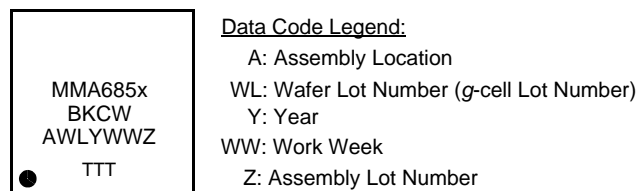

Figure 3. Part Marking

### 1.3 Internal Block Diagram

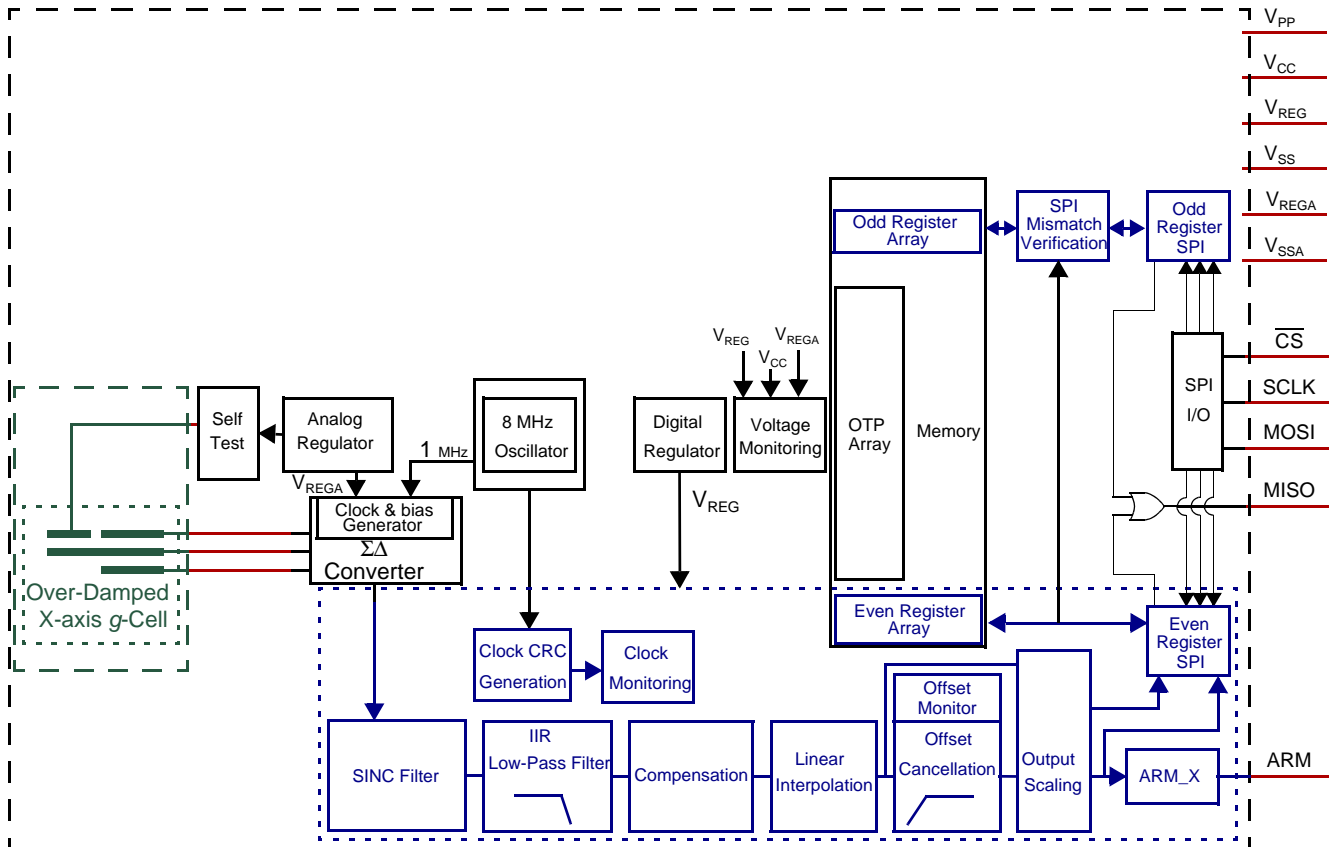

Figure 4. Block Diagram

## 1.4 Pin Connections

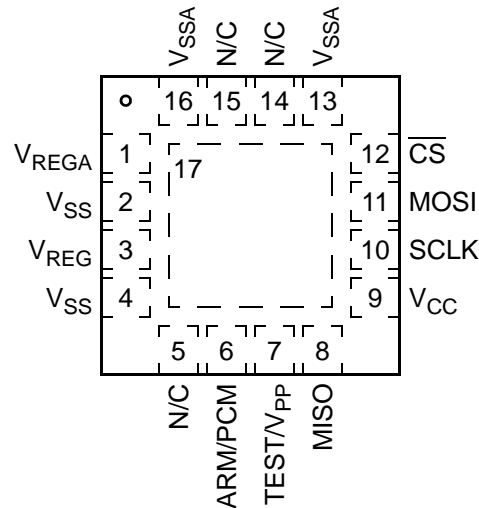

Figure 5. 16-Pin QFN Package, Top View

Table 2. Pin Description

Pin	Pin Name	Formal Name	Definition
1	V <sub>REGA</sub>	Analog Supply	This pin is connected to the power supply for the internal analog circuitry. An external capacitor must be connected between this pin and V <sub>SSA</sub> . Reference <a href="#">Figure 1</a> .
2	V <sub>SS</sub>	Digital GND	This pin is the power supply return node for the digital circuitry.
3	V <sub>REG</sub>	Digital Supply	This pin is connected to the power supply for the internal digital circuitry. An external capacitor must be connected between this pin and V <sub>SS</sub> . Reference <a href="#">Figure 1</a> .
4	V <sub>SS</sub>	Digital GND	This pin is the power supply return node for the digital circuitry.
5	N/C	No Connect	No Connection
6	ARM/PCM	Arm Output / PCM Output	The function of this pin is configurable via the DEVCFG register as described in <a href="#">Section 3.1.6.5</a> . When the arming output is selected, ARM can be configured as an open drain, active low output with a pullup current; or an open drain, active high output with a pulldown current. Alternatively, this pin can be configured as a digital output with a PCM signal proportional to the acceleration data. Reference <a href="#">Section 3.8.9</a> and <a href="#">Section 3.8.10</a> . If unused, this pin must be left unconnected.
7	TEST/V <sub>PP</sub>	Programming Voltage	This pin provides the power for factory programming of the OTP registers. This pin must be connected to V <sub>SS</sub> in the application.
8	MISO	SPI Data Out	This pin functions as the serial data output for the SPI port.
9	V <sub>CC</sub>	Supply	This pin supplies power to the device. An external capacitor must be connected between this pin and V <sub>SS</sub> . Reference <a href="#">Figure 1</a> .
10	SCLK	SPI Clock	This input pin provides the serial clock to the SPI port. An internal pulldown device is connected to this pin.
11	MOSI	SPI Data In	This pin functions as the serial data input to the SPI port. An internal pulldown device is connected to this pin.
12	CS	Chip Select	This input pin provides the chip select for the SPI port. An internal pullup device is connected to this pin.
13	V <sub>SSA</sub>	Analog GND	This pin is the power supply return node for analog circuitry.
14	N/C	No Connect	No Connection
15	N/C	No Connect	No Connection
16	V <sub>SSA</sub>	Analog GND	This pin is the power supply return node for analog circuitry.
17	PAD	Die Attach Pad	This pin is the die attach flag, and is internally connected to V <sub>SS</sub> .
	Corner Pads	Corner Pads	The corner pads are internally connected to V <sub>SS</sub> .

## 2 Electrical Characteristics

### 2.1 Maximum Ratings

Maximum ratings are the extreme limits to which the device can be exposed without permanently damaging it.

#	Rating	Symbol	Value	Unit	
1	Supply Voltage	$V_{CC}$	-0.3 to +7.0	V	(3)
2	$C_{REG}$ , $C_{REGA}$	$V_{REG}$	-0.3 to +3.0	V	(3)
3	SCLK, $\overline{CS}$ , MOSI, $V_{PP}/TEST$	$V_{IN}$	-0.3 to $V_{CC} + 0.3$	V	(3)
4	ARM	$V_{IN}$	-0.3 to $V_{CC} + 0.3$	V	(3)
5	MISO (high impedance state)	$V_{IN}$	-0.3 to $V_{CC} + 0.3$	V	(3)
6	Acceleration without hitting internal g-cell stops	$g_{gcell\_Clip}$	$\pm 500$	g	(3, 18)
7	Acceleration without saturation of internal circuitry	$g_{ADC\_Clip}$	$\pm 375$	g	(3)
8	Powered Shock (six sides, 0.5 ms duration)	$g_{pms}$	$\pm 1500$	g	(5, 18)
9	Unpowered Shock (six sides, 0.5 ms duration)	$g_{shock}$	$\pm 2000$	g	(5, 18)
10	Drop Shock (to concrete surface)	$h_{DROP}$	1.2	m	(5)
11	Electrostatic Discharge Human Body Model (HBM)	$V_{ESD}$	$\pm 2000$	V	(5)
12	Charge Device Model (CDM)	$V_{ESD}$	$\pm 750$	V	(5)
13	Machine Model (MM)	$V_{ESD}$	$\pm 200$	V	(5)
14	Storage Temperature Range	$T_{stg}$	-40 to +125	°C	(5)
15	Thermal Resistance - Junction to Case	$\theta_{JC}$	2.5	°C/W	(14)

### 2.2 Operating Range

The operating ratings are the limits normally expected in the application and define the range of operation.

#	Characteristic	Symbol	Min	Typ	Max	Units	
16	Supply Voltage	$V_{CC}$	$V_L$	$V_{TYP}$	$V_H$	V	(15)
17	Standard Operating Voltage, 3.3 V		+3.135	+3.3	+5.25		
	Standard Operating Voltage, 5.0 V		—	+5.0	—	V	(15)
18	Operating Ambient Temperature Range Verified by 100 % Final Test	$T_A$	$T_L$	—	$T_H$	C	(1)
20	Power-on Ramp Rate ( $V_{CC}$ )	$V_{CC\_r}$	0.000033	—	3300	V/ $\mu$ s	(19)

## 2.3 Electrical Characteristics - Power Supply and I/O

$V_L \leq (V_{CC} - V_{SS}) \leq V_H$ ,  $T_L \leq T_A \leq T_H$ ,  $|\Delta T_A| < 25$  K/min unless otherwise specified

#	Characteristic	Symbol	Min	Typ	Max	Units	
21	Supply Current (4)	$I_{DD}$	3.0	—	7.0	mA	(1)
22	Power Supply Monitor Thresholds (See Figure 9) $V_{CC}$ Undervoltage (Falling) (4)	$V_{CC\_UV\_f}$	2.74	—	3.02	V	(3, 6)
23	$V_{REG}$ Undervoltage (Falling) (4)	$V_{REG\_UV\_f}$	2.10	—	2.25	V	(3, 6)
24	$V_{REG}$ Overvoltage (Rising) (4)	$V_{REG\_OV\_r}$	2.65	—	2.85	V	(3, 6)
25	$V_{REGA}$ Undervoltage (Falling) (4)	$V_{REGA\_UV\_f}$	2.20	—	2.35	V	(3, 6)
26	$V_{REGA}$ Overvoltage (Rising) (4)	$V_{REGA\_OV\_r}$	2.65	—	2.85	V	(3, 6)
27	Power Supply Monitor Hysteresis $V_{CC}$ Undervoltage (Falling)	$V_{HYST}$	65	100	110	mV	(3)
28	$V_{REG}$ Undervoltage, $V_{REG}$ Overvoltage	$V_{HYST}$	20	100	210	mV	(3)
29	$V_{REGA}$ Undervoltage, $V_{REGA}$ Overvoltage	$V_{HYST}$	20	100	150	mV	(3)
30	Power Supply RESET Thresholds (See Figure 6, and Figure 9) $V_{REG}$ Undervoltage RESET (Falling) (4)	$V_{REG\_UVR\_f}$	1.764	—	2.024	V	(3, 6)
31	$V_{REG}$ Undervoltage RESET (Rising) (4)	$V_{REG\_UVR\_r}$	1.876	—	2.152	V	(3, 6)
32	$V_{REG}$ RESET Hysteresis	$V_{HYST}$	80	—	140	mV	(3)
33	Internally Regulated Voltages $V_{REG}$ (4)	$V_{REG}$	2.42	2.50	2.58	V	(1, 3)
34	$V_{REGA}$ (4)	$V_{REGA}$	2.42	2.50	2.58	V	(1, 3)
35	External Filter Capacitor ( $C_{REG}$ , $C_{REGA}$ ) Value	$C_{REG}$	700	1000	1500	nF	(19)
36	ESR (including interconnect resistance)	ESR	—	—	400	m $\Omega$	(19)
37	Power Supply Coupling 50 kHz $\leq f_n \leq$ 300 kHz		—	—	0.004	LSB/mv	(19)
38	4 MHz $\leq f_n \leq$ 100 MHz		—	—	0.004	LSB/mv	(19)
39	Output High Voltage (MISO, PCM) 3.15 V $\leq (V_{CC} - V_{SS}) \leq$ 3.45 V ( $I_{Load} = -1$ mA) (4)	$V_{OH\_3}$	$V_{CC} - 0.2$	—	—	V	(2, 3)
40	4.75 V $\leq (V_{CC} - V_{SS}) \leq$ 5.25 V ( $I_{Load} = -1$ mA) (4)	$V_{OH\_5}$	$V_{CC} - 0.4$	—	—	V	(2, 3)
41	Output Low Voltage (MISO, PCM) 3.15 V $\leq (V_{CC} - V_{SS}) \leq$ 3.45 V ( $I_{Load} = 1$ mA) (4)	$V_{OL\_3}$	—	—	0.2	V	(2, 3)
42	4.75 V $\leq (V_{CC} - V_{SS}) \leq$ 5.25 V ( $I_{Load} = 1$ mA) (4)	$V_{OL\_5}$	—	—	0.4	V	(2, 3)
43	Open Drain Output High Voltage (ARM) 3.15 V $\leq (V_{CC} - V_{SS}) \leq$ 3.45 V ( $I_{ARM} = -1$ mA) (4)	$V_{ODH\_3}$	$V_{CC} - 0.2$	—	—	V	(2, 3)
44	4.75 V $\leq (V_{CC} - V_{SS}) \leq$ 5.25 V ( $I_{ARM} = -1$ mA) (4)	$V_{ODH\_5}$	$V_{CC} - 0.4$	—	—	V	(2, 3)
45	Open Drain Output Pulldown Current (ARM) 3.15 V $\leq (V_{CC} - V_{SS}) \leq$ 3.45 V ( $V_{ARM} = 1.5$ V) (4)	$I_{ODPD\_3}$	50	—	100	$\mu$ A	(2, 3)
46	4.75 V $\leq (V_{CC} - V_{SS}) \leq$ 5.25 V ( $V_{ARM} = 1.5$ V) (4)	$I_{ODPD\_5}$	50	—	100	$\mu$ A	(2, 3)
47	Open Drain Output Low Voltage (ARM) 3.15 V $\leq (V_{CC} - V_{SS}) \leq$ 3.45 V ( $I_{ARM} = 1$ mA) (4)	$V_{ODH\_3}$	—	—	0.2	V	(2, 3)
48	4.75 V $\leq (V_{CC} - V_{SS}) \leq$ 5.25 V ( $I_{ARM} = 1$ mA) (4)	$V_{ODH\_5}$	—	—	0.4	V	(2, 3)
49	Open Drain Output Pullup Current (ARM) 3.15 V $\leq (V_{CC} - V_{SS}) \leq$ 3.45 V ( $V_{ARM} = 1.5$ V) (4)	$I_{ODPU\_3}$	-100	—	-50	$\mu$ A	(2, 3)
50	4.75 V $\leq (V_{CC} - V_{SS}) \leq$ 5.25 V ( $V_{ARM} = 1.5$ V) (4)	$I_{ODPU\_5}$	-100	—	-50	$\mu$ A	(2, 3)
51	Input High Voltage $\overline{CS}$ , SCLK, MOSI (4)	$V_{IH}$	2.0	—	—	V	(3, 6)
52	Input Low Voltage $\overline{CS}$ , SCLK, MOSI (4)	$V_{IL}$	—	—	1.0	V	(3, 6)
53	Input Voltage Hysteresis $\overline{CS}$ , SCLK, MOSI (4)	$V_{I\_HYST}$	0.125	—	0.500	V	(19)
54	Input Current High (at $V_{IH}$ ) (SCLK, MOSI) (4)	$I_{IH}$	-260	-50	-30	$\mu$ A	(2, 3)
55	Low (at $V_{IL}$ ) ( $\overline{CS}$ ) (4)	$I_{IL}$	30	50	260	$\mu$ A	(2, 3)

## 2.4 Electrical Characteristics - Sensor and Signal Chain

$V_L \leq (V_{CC} - V_{SS}) \leq V_H$ ,  $T_L \leq T_A \leq T_H$ ,  $|\Delta T_A| < 25$  K/min unless otherwise specified

#	Characteristic	Symbol	Min	Typ	Max	Units	
56	Digital Sensitivity (SPI, 10-bit Output) 25 g (MMA6851)	(4) SENS	—	20.479	—	LSB/g	(1, 9)
57	50 g (MMA6853)	(4) SENS	—	9.766	—	LSB/g	(1, 9)
58	60 g (MMA6856)	(4) SENS	—	8.192	—	LSB/g	(1, 9)
59	120 g (MMA6855)	(4) SENS	—	4.096	—	LSB/g	(1, 9)
60	Sensitivity Error $T_A = 25$ °C	(4) $\Delta$ SENS	-4	—	+4	%	(1)
61	$-40$ °C $\leq T_A \leq 105$ °C	(4) $\Delta$ SENS	-5	—	+5	%	(1)
67	$-40$ °C $\leq T_A \leq 105$ °C, $V_{CC\_UV\_f} \leq V_{CC} - V_{SS} \leq V_L$	$\Delta$ SENS	-5	—	+5	%	(3)
68	Offset at 0 g (No Offset Cancellation) 10-bits, unsigned	(4) OFFSET	452	512	572	LSB	(1)
69	10-bits, signed	(4) OFFSET	-60	0	+60	LSB	(1)
70	10-bits, unsigned, $V_{CC\_UV\_f} \leq V_{CC} - V_{SS} \leq V_L$	OFFSET	452	512	572	LSB	(3)
71	10-bits, signed, $V_{CC\_UV\_f} \leq V_{CC} - V_{SS} \leq V_L$	OFFSET	-60	0	+60	LSB	(3)
72	Offset Monitor Thresholds Positive Threshold (10-bits, unsigned)	OFFTHR <sub>POS</sub>	—	612	—	LSB	(7)
73	Negative Threshold (10-bits, unsigned)	OFFTHR <sub>NEG</sub>	—	412	—	LSB	(7)
74	Range of Output (SPI, 10-bits, unsigned) Normal	RANGE	32	—	992	LSB	(7)
75	Fault Response Code	FAULT	—	0	—	LSB	(7)
76	Unused Codes	UNUSED	1	—	31	LSB	(7)
77	Unused Codes	UNUSED	993	—	1023	LSB	(7)
78	Range of Output (SPI, 10-bits, signed) Normal	RANGE	-480	—	480	LSB	(7)
79	Fault Response Code	FAULT	—	-512	—	LSB	(7)
80	Unused Codes	UNUSED	-511	—	-481	LSB	(7)
81	Unused Codes	UNUSED	481	—	511	LSB	(7)
82	Nonlinearity	(4) NL <sub>OUT</sub>	-1	—	1	% FSR	(3)
83	System Output Noise RMS (10-bit, All Ranges, 400 Hz, 4-pole LPF)	$n_{RMS}$	—	—	0.5	LSB	(3)
84	Peak to Peak (10-bit, All Ranges, 400 Hz, 4-pole LPF)	$n_{P-P}$	—	—	1.0	LSB	(3)
85	Cross-axis Sensitivity $V_{ZX}$	(4) $V_{ZX}$	-4	—	+4	%	(3)
86	$V_{YX}$	(4) $V_{YX}$	-4	—	+4	%	(3)
87	Self-test Output Change (Ref <a href="#">Section 3.6</a> ) STMAG = 0, $T_A = 25$ °C	(4) $\Delta$ ST <sub>Low25</sub>	$\Delta$ ST <sub>MIN</sub> 11.25	$\Delta$ ST <sub>NOM</sub> 15	$\Delta$ ST <sub>MAX</sub> 18.75	g	(1)
88	STMAG = 0, $-40$ °C $\leq T_A \leq 105$ °C	(4) $\Delta$ ST <sub>Low</sub>	10.68	15	19.69	g	(1)
89	STMAG = 1, $T_A = 25$ °C	(4) $\Delta$ ST <sub>HI25</sub>	22.5	30	37.5	g	(1)
90	STMAG = 1, $-40$ °C $\leq T_A \leq 105$ °C	(4) $\Delta$ ST <sub>HI</sub>	21.37	30	39.38	g	(1)
91	STMAG = 0, $-40$ °C $\leq T_A \leq 105$ °C	(4) $\Delta$ ST <sub>Low</sub>	10.68	15	19.69	g	(3)
92	$V_{CC\_UV\_f} \leq V_{CC} - V_{SS} \leq V_L$ STMAG = 1, $-40$ °C $\leq T_A \leq 105$ °C $V_{CC\_UV\_f} \leq V_{CC} - V_{SS} \leq V_L$	$\Delta$ ST <sub>HI</sub>	21.37	30	39.38	g	(3)
93	Acceleration (without hitting internal g-cell stops) Any Range Positive/Negative	$g_{g-cell\_Clip}$	500	560	600	g	(19)

## 2.5 Dynamic Electrical Characteristics - Signal Chain

$V_L \leq (V_{CC} - V_{SS}) \leq V_H$ ,  $T_L \leq T_A \leq T_H$ ,  $|\Delta T_A| < 25$  K/min unless otherwise specified

#	Characteristic	Symbol	Min	Typ	Max	Units	
94	DSP Sample Rate (LPF 0,1,2,3,4,5)	$t_s$	—	$64/f_{OSC}$	—	s	(7)
95	DSP Sample Rate (LPF 8,9,10,11,12,13)	$t_s$	—	$128/f_{OSC}$	—	s	(7)
96	Interpolation Sample Rate	$t_{INTERP}$	—	$t_s/2$	—	s	(7)
97	Datapath Latency (excluding g-cell and Low Pass Filter) $T_S = 64/f_{OSC}$ (4)	$t_{DataPath\_8}$	33.0	34.8	36.5	$\mu$ s	(7, 16)
98	$T_S = 128/f_{OSC}$ (4)	$t_{DataPath\_16}$	51.9	54.6	57.4	$\mu$ s	(7, 16)
99	Low-Pass Filter ( $t_s = 8 \mu$ s) Cutoff frequency 0: 100 Hz, 4-pole (4)	$f_{C0(LPF)}$	95	100	105	Hz	(3, 7, 17)
100	Cutoff frequency 1: 300 Hz, 4-pole (4)	$f_{C1(LPF)}$	285	300	315	Hz	(7, 17)
101	Cutoff frequency 2: 400 Hz, 4-pole (4)	$f_{C2(LPF)}$	380	400	420	Hz	(7, 17)
102	Cutoff frequency 3: 800 Hz, 4-pole (4)	$f_{C3(LPF)}$	760	800	840	Hz	(7, 17)
103	Cutoff frequency 4: 1000 Hz, 4-pole (4)	$f_{C4(LPF)}$	950	1000	1050	Hz	(7, 17)
104	Cutoff frequency 5: 400 Hz, 3-pole (4)	$f_{C5(LPF)}$	380	400	420	Hz	(7, 17)
105	Low-Pass Filter ( $t_s = 16 \mu$ s) Cutoff frequency 8: 50 Hz, 4-pole (4)	$f_{C8(LPF)}$	47.5	50	52.5	Hz	(7, 17)
106	Cutoff frequency 9: 150 Hz, 4-pole (4)	$f_{C9(LPF)}$	142.5	150	157.5	Hz	(7, 17)
107	Cutoff frequency 10: 200 Hz, 4-pole (4)	$f_{C10(LPF)}$	190	200	210	Hz	(7, 17)
108	Cutoff frequency 11: 400 Hz, 4-pole (4)	$f_{C11(LPF)}$	380	400	420	Hz	(7, 17)
109	Cutoff frequency 12: 500 Hz, 4-pole (4)	$f_{C12(LPF)}$	475	500	525	Hz	(7, 17)
110	Cutoff frequency 13: 200 Hz, 3-pole (4)	$f_{C13(LPF)}$	190	200	210	Hz	(7, 17)
111	Offset Cancellation (Normal Mode, 10-bit Output) Offset Averaging Period (4)	$OFF_{AVEPER}$	—	6.291456	—	s	(7)
112	Offset Slew Rate (4)	$OFF_{SLEW}$	—	0.2384	—	LSB/s	(7)
113	Offset Update Rate (4)	$OFF_{RATE}$	—	1049	—	ms	(7)
114	Offset Correction Value per Update Positive (4)	$OFF_{CORRP}$	—	0.25	—	LSB	(7)
115	Offset Correction Value per Update Negative (4)	$OFF_{CORRN}$	—	-0.25	—	LSB	(7)
116	Offset Correction Threshold Positive (4)	$OFF_{THP}$	—	0.125	—	LSB	(7)
117	Offset Correction Threshold Negative (4)	$OFF_{THN}$	—	0.125	—	LSB	(7)
118	Offset Monitor Bypass Time after Self-test Deactivation	$t_{ST\_OMB}$	—	320	—	$t_s$	(3, 7)
119	Time Between Acceleration Data Requests	$t_{ACC\_REQ}$	15	—	—	$\mu$ s	(3, 7, 20)
120	Arming Output Activation Time (ARM, $I_{ARM} = 200 \mu$ A) Moving Average and Count Arming Modes (2,3,4,5)	$t_{ARM}$	0	—	1.05	$\mu$ s	(3, 12)
121	Unfiltered Mode Activation Delay (Reference Figure 29)	$t_{ARM\_UF\_DLY}$	0	—	1.05	$\mu$ s	(3, 12)
122	Unfiltered Mode Arm Assertion Time (Reference Figure 29)	$t_{ARM\_UF\_ASSERT}$	5.00	—	6.579	$\mu$ s	(3)
123	Sensing Element Natural Frequency ( $-40 \text{ }^\circ\text{C} \leq T_A \leq 105 \text{ }^\circ\text{C}$ )	$f_{gcell}$	10791	—	15879	Hz	(19)
124	Sensing Element Cutoff Frequency ( $-3$ dB ref. to 0 Hz, $-40 \text{ }^\circ\text{C} \leq T_A \leq 105 \text{ }^\circ\text{C}$ )	$f_{gcell}$	0.851	—	2.29	kHz	(19)
125	Sensing Element Damping Ratio ( $-40 \text{ }^\circ\text{C} \leq T_A \leq 105 \text{ }^\circ\text{C}$ )	$\zeta_{gcell}$	2.46	—	9.36	—	(19)
126	Sensing Element Delay (@100 Hz, $-40 \text{ }^\circ\text{C} \leq T_A \leq 105 \text{ }^\circ\text{C}$ )	$f_{gcell\_delay}$	70	—	187	$\mu$ s	(19)
127	Package Resonance Frequency	$f_{Package}$	100	—	—	kHz	(19)
128	Package Quality Factor	$Q_{Package}$	1	—	5	—	(19)



## 2.6 Dynamic Electrical Characteristics - Supply and SPI

$V_L \leq (V_{CC} - V_{SS}) \leq V_H$ ,  $T_L \leq T_A \leq T_H$ ,  $|\Delta T_A| < 25$  K/min unless otherwise specified

#	Characteristic	Symbol	Min	Typ	Max	Units	
129	Power-On Recovery Time ( $V_{CC} = V_{CCMIN}$ to first SPI access)	$t_{OP}$	—	—	10	ms	(3)
130	Power-On Recovery Time (Internal POR to first SPI access)	$t_{OP}$	—	—	840	$\mu$ s	(3, 7)
131	Internal Oscillator Frequency (4)	$f_{OSC}$	7.6	8	8.4	MHz	(7)
132	Test Frequency - Divided from Internal Oscillator	$f_{OSCTST}$	0.95	1	1.05	MHz	(1)
Serial Interface Timing (See Figure 7, $C_{MISO} \leq 80$ pF, $R_{MISO} \geq 10$ k $\Omega$ )							
133	Clock (SCLK) period (10 % of $V_{CC}$ to 10 % of $V_{CC}$ ) (4)	$t_{SCLK}$	120	—	—	ns	(3)
134	Clock (SCLK) high time (90 % of $V_{CC}$ to 90 % of $V_{CC}$ ) (4)	$t_{SCLKH}$	40	—	—	ns	(3)
135	Clock (SCLK) low time (10 % of $V_{CC}$ to 10 % of $V_{CC}$ ) (4)	$t_{SCLKL}$	40	—	—	ns	(3)
136	Clock (SCLK) rise time (10 % of $V_{CC}$ to 90 % of $V_{CC}$ )	$t_{SCLKR}$	—	15	40	ns	(19)
137	Clock (SCLK) fall time (90 % of $V_{CC}$ to 10 % of $V_{CC}$ )	$t_{SCLKF}$	—	15	28	ns	(19)
138	$\overline{CS}$ asserted to SCLK high ( $\overline{CS} = 10$ % of $V_{CC}$ to SCLK = 10 % of $V_{CC}$ ) (4)	$t_{LEAD}$	60	—	—	ns	(3)
139	$\overline{CS}$ asserted to MISO valid ( $\overline{CS} = 10$ % of $V_{CC}$ to MISO = 10/90 % of $V_{CC}$ ) (4)	$t_{ACCESS}$	—	—	60	ns	(3)
140	Data setup time (MOSI = 10/90 % of $V_{CC}$ to SCLK = 10 % of $V_{CC}$ ) (4)	$t_{SETUP}$	20	—	—	ns	(3)
141	MOSI Data hold time (SCLK = 90 % of $V_{CC}$ to MOSI = 10/90 % of $V_{CC}$ ) (4)	$t_{HOLD\_IN}$	10	—	—	ns	(3)
142	MISO Data hold time (SCLK = 90 % of $V_{CC}$ to MISO = 10/90 % of $V_{CC}$ ) (4)	$t_{HOLD\_OUT}$	0	—	—	ns	(3)
143	SCLK low to data valid (SCLK = 10 % of $V_{CC}$ to MISO = 10/90 % of $V_{CC}$ ) (4)	$t_{VALID}$	—	—	40	ns	(3)
144	SCLK low to $\overline{CS}$ high (SCLK = 10 % of $V_{CC}$ to $\overline{CS} = 90$ % of $V_{CC}$ ) (4)	$t_{LAG}$	60	—	—	ns	(3)
145	$\overline{CS}$ high to MISO disable ( $\overline{CS} = 90$ % of $V_{CC}$ to MISO = Hi Z) (4)	$t_{DISABLE}$	—	—	60	ns	(3)
146	$\overline{CS}$ high to $\overline{CS}$ low ( $\overline{CS} = 90$ % of $V_{CC}$ to $\overline{CS} = 90$ % of $V_{CC}$ ) (4)	$t_{CSN}$	526	—	—	ns	(3)
147	SCLK low to $\overline{CS}$ low (SCLK = 10 % of $V_{CC}$ to $\overline{CS} = 90$ % of $V_{CC}$ ) (4)	$t_{CLKCS}$	60	—	—	ns	(3)
148	$\overline{CS}$ high to SCLK high ( $\overline{CS} = 90$ % of $V_{CC}$ to SCLK = 90 % of $V_{CC}$ )	$t_{CSCLK}$	60	—	—	ns	(19)

- Parameters tested 100 % at final test.
- Parameters tested 100 % at wafer probe.
- Parameters verified by characterization
- Indicates a critical characteristic.
- Verified by qualification testing.
- Parameters verified by pass/fail testing in production.
- Functionality guaranteed by modeling, simulation and/or design verification. Circuit integrity assured through IDDQ and scan testing. Timing is determined by internal system clock frequency.
- N/A
- Devices are trimmed at 100 Hz with 1000 Hz low-pass filter option selected. Response is corrected to 0 Hz response.
- Low-pass filter cutoff frequencies shown are -3 dB referenced to 0 Hz response.
- Power supply ripple at frequencies greater than 900 kHz should be minimized to the greatest extent possible.
- Time from falling edge of  $\overline{CS}$  to ARM output valid.
- N/A
- Thermal resistance between the die junction and the exposed pad; cold plate is attached to the exposed pad.
- Device characterized at all values of  $V_L$  and  $V_H$ . Production test is conducted at all typical voltages ( $V_{TYP}$ ) unless otherwise noted.
- Data path Latency is the signal latency from g-cell to SPI output disregarding filter group delays.
- Filter characteristics are specified independently, and do not include g-cell frequency response.
- Electrostatic Deflection Test completed during wafer probe.
- Verified by simulation.
- Acceleration Data Request timing constraint only applies for proper operation of the Arming Function.

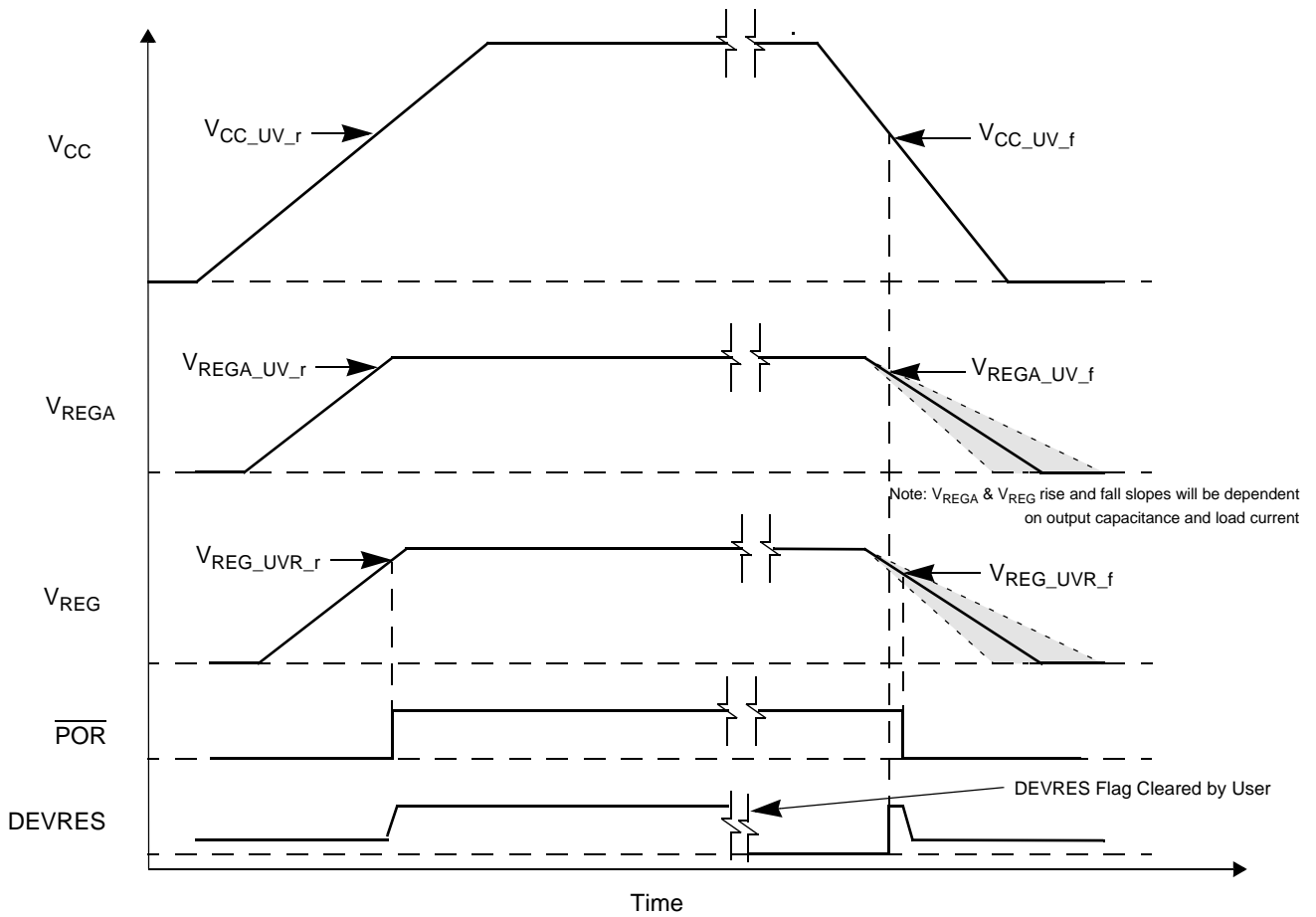

Figure 6. Power-Up Timing

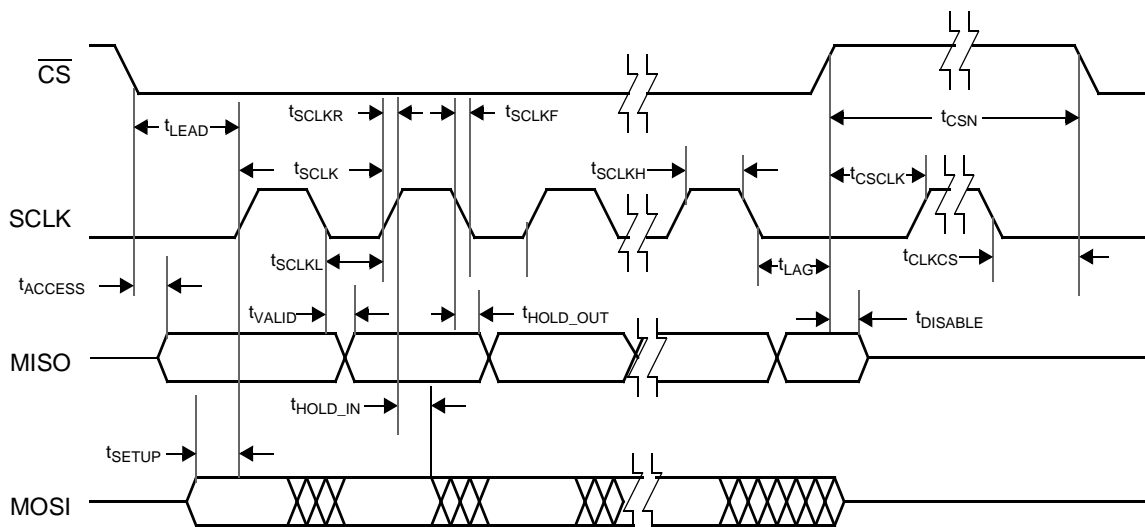

Figure 7. Serial Interface Timing

## 3 Functional Description

### 3.1 Customer Accessible Data Array

A customer accessible data array allows for each device to be customized. The array consists of an OTP factory programmable block and read/write registers for device programmability and status. The OTP and writable register blocks incorporate independent CRC circuitry for fault detection (reference [Section 3.2](#)). The writable register block includes a locking mechanism to prevent unintended changes during normal operation. Portions of the array are reserved for factory-programmed trim values. The customer accessible data is shown in [Table 3](#).

**Table 3. Customer Accessible Data**

Location		Bit Function								Type	
Addr	Register	7	6	5	4	3	2	1	0		
\$00	SN0	SN[7]	SN[6]	SN[5]	SN[4]	SN[3]	SN[2]	SN[1]	SN[0]	F	
\$01	SN1	SN[15]	SN[14]	SN[13]	SN[12]	SN[11]	SN[10]	SN[9]	SN[8]		
\$02	SN2	SN[23]	SN[22]	SN[21]	SN[20]	SN[19]	SN[18]	SN[17]	SN[16]		
\$03	SN3	SN[31]	SN[30]	SN[29]	SN[28]	SN[27]	SN[26]	SN[25]	SN[24]		
\$04	Reserved	Reserved	Reserved	Reserved	Reserved	Reserved	Reserved	Reserved	Reserved		
\$05	Reserved	Reserved	Reserved	Reserved	Reserved	Reserved	Reserved	Reserved	Reserved		
\$06	FCTCFG	STMAG	0	0	0	0	0	0	0		
\$07	Invalid Address: "Invalid Register Request"										
\$08	PN	PN[7]	PN[6]	PN[5]	PN[4]	PN[3]	PN[2]	PN[1]	PN[0]		
\$09	Invalid Address: "Invalid Register Request"										
\$0A	DEVCTL	RES_1	RES_0	Reserved	Reserved	Reserved	Reserved	Reserved	Reserved	R/W	
\$0B	DEVCFG	Reserved	Reserved	ENDINIT	$\overline{SD}$	OFMON	A_CFG[2]	A_CFG[1]	A_CFG[0]		
\$0C	DEVCFG_X	ST	Reserved	Reserved	Reserved	LPF[3]	LPF[2]	LPF[1]	LPF[0]		
\$0D	Invalid Address: "Invalid Register Request"										
\$0E	ARMCFG	Reserved	Reserved	APS[1]	APS[0]	AWS_N[1]	AWS_N[0]	AWS_P[1]	AWS_P[0]		
\$0F	Invalid Address: "Invalid Register Request"										
\$10	ARMT_P	AT_P[7]	AT_P[6]	AT_P[5]	AT_P[4]	AT_P[3]	AT_P[2]	AT_P[1]	AT_P[0]		
\$11	Invalid Address: "Invalid Register Request"										
\$12	ARMT_N	AT_N[7]	AT_N[6]	AT_N[5]	AT_N[4]	AT_N[3]	AT_N[2]	AT_N[1]	AT_N[0]		
\$13	Invalid Address: "Invalid Register Request"										
\$14	DEVSTAT	UNUSED	IDE	SDOV	DEVINIT	MISOERR	0	OFFSET	DEVRES	R	
\$15	COUNT	COUNT[7]	COUNT[6]	COUNT[5]	COUNT[4]	COUNT[3]	COUNT[2]	COUNT[1]	COUNT[0]		
\$16	OFFCORR_X	OFFCORR_X[7]	OFFCORR_X[6]	OFFCORR_X[5]	OFFCORR_X[4]	OFFCORR_X[3]	OFFCORR_X[2]	OFFCORR_X[1]	OFFCORR_X[0]		
\$17	Invalid Address: "Invalid Register Request"										
\$1C	Reserved	Reserved	Reserved	Reserved	Reserved	Reserved	Reserved	Reserved	Reserved		
\$1D	Reserved	Reserved	Reserved	Reserved	Reserved	Reserved	Reserved	Reserved	Reserved		

Type codes

- F: Factory programmed OTP location
- R/W: Read/write register
- R: Read-only register
- N/A: Not applicable

### 3.1.1 Device Serial Number Registers

A unique serial number is programmed into the serial number registers of each MMA685x device during manufacturing. The serial number is composed of the following information:

Bit Range	Content
S12 to S0	Serial Number
S31 to S13	Lot Number

Serial numbers begin at 1 for all produced devices in each lot, and are sequentially assigned. Lot numbers begin at 1 and are sequentially assigned. No lot will contain more devices than can be uniquely identified by the 13-bit serial number. Depending on lot size and quantities, all possible lot numbers and serial numbers may not be assigned.

The serial number registers are included in the OTP shadow register array CRC verification. Reference [Section 3.2.1](#) for details regarding the CRC verification. Beyond this, the contents of the serial number registers have no impact on device operation or performance, and are only used for traceability purposes.

### 3.1.2 Reserved Registers

These reserved registers are read-only and have no impact on device operation or performance.

**Table 4. Reserved Registers**

Location		Bit							
Address	Register	7	6	5	4	3	2	1	0
\$04	Reserved	Reserved	Reserved	Reserved	Reserved	Reserved	Reserved	Reserved	Reserved
\$05	Reserved	Reserved	Reserved	Reserved	Reserved	Reserved	Reserved	Reserved	Reserved

### 3.1.3 Factory Configuration Registers

The factory configuration register is a one time programmable, read only register which contains customer specific device configuration information that is programmed by NXP.

**Table 5. Factory Configuration Register**

Location		Bit							
Address	Register	7	6	5	4	3	2	1	0
\$06	FCTCFG	STMAG	0	0	0	0	0	0	0

#### 3.1.3.1 Self-test Magnitude Selection Bits (STMAG)

The self-test magnitude selection bits indicate if the nominal self-test deflection value is set to the low or high value as shown in the table below.

STMAG	Full-Scale Acceleration Range	Nominal Self-test Deflection Value (Reference <a href="#">Section 2.4</a> )
0	$\leq 60\text{ g}$	$\Delta\text{ST}_{\text{Low}}$
1	$> 60\text{ g}$	$\Delta\text{ST}_{\text{Hi}}$

### 3.1.4 Part Number Register (PN)

The part number register is a one time programmable, read only register which contains two digits of the device part number to identify the axis and range information. The contents of this register have no impact on device operation or performance.

**Table 6. Part Number Register**

Location		Bit							
Address	Register	7	6	5	4	3	2	1	0
\$08	PN	PN[7]	PN[6]	PN[5]	PN[4]	PN[3]	PN[2]	PN[1]	PN[0]

PN Register Value		Range Reference <a href="#">Section 2.4</a>
Decimal	HEX	
51	\$33	20
52	\$34	35
53	\$35	50
54	\$36	75
55	\$37	100
56	\$38	60

### 3.1.5 Device Control Register (DEVCTL)

The device control register is a read-write register which contains device control operations that can be applied during both initialization and normal operation.

**Table 7. Device Control Register**

Location		Bit							
Address	Register	7	6	5	4	3	2	1	0
\$0A	DEVCTL	RES_1	RES_0	Reserved	Reserved	Reserved	Reserved	Reserved	Reserved
Reset Value		0	0	0	0	0	0	0	0

#### 3.1.5.1 Reset Control (RES\_1, RES\_0)

A series of three consecutive register write operations to the reset control bits in the DEVCTL register will cause a device reset. To reset the internal digital circuitry, the following register write operations must be performed in the order shown below. The register write operations must be consecutive SPI commands in the order shown or the device will not be reset.

Register Write to DEVCTL	RES_1	RES_0	Effect
SPI Register Write 1	0	0	No Effect
SPI Register Write 2	1	1	No Effect
SPI Register Write 3	0	1	Device RESET

The response to the Register Write returns '0' for RES\_1 and RES\_0. A Register Read of RES\_1 and RES\_0 returns '0' and terminates the reset sequence.

#### 3.1.5.2 Reserved Bits (DEVCTL[5:0])

Bits 5 through 0 of the DEVCTL register are reserved. A write to the reserved bits must always be logic '0' for normal device operation and performance.

### 3.1.6 Device Configuration Register (DEVCFG)

The device configuration register is a read/write register which contains data for general device configuration. The register can be written during initialization but is locked once the ENDINIT bit is set. This register is included in the writable register CRC check. Refer to [Section 3.2.2](#) for details.

**Table 8. Device Configuration Register**

Location		Bit							
Address	Register	7	6	5	4	3	2	1	0
\$0B	DEVCFG	Reserved	Reserved	ENDINIT	$\overline{SD}$	OFMON	A_CFG[2]	A_CFG[1]	A_CFG[0]
Reset Value		0	0	0	0	0	0	0	0

#### 3.1.6.1 Reserved Bits (Reserved)

Bits 6 and 7 of the DEVCFG register are reserved. A write to the reserved bits must always be logic '0' for normal device operation and performance.

#### 3.1.6.2 End of Initialization Bit (ENDINIT)

The ENDINIT bit is a control bit used to indicate that the user has completed all device and system level initialization tests, and that MMA685x will operate in normal mode. Once the ENDINIT bit is set, writes to all writable register bits are inhibited except for the DEVCTL register. Once written, the ENDINIT bit can only be cleared by a device reset. The writable register CRC check (reference [Section 3.2.2](#)) is only enabled when the ENDINIT bit is set.

#### 3.1.6.3 $\overline{SD}$ Bit

The  $\overline{SD}$  bit determines the format of acceleration data results. If the  $\overline{SD}$  bit is set to a logic '1', unsigned results are transmitted, with the zero-g level represented by a nominal value of 512. If the  $\overline{SD}$  bit is cleared, signed results are transmitted, with the zero-g level represented by a nominal value of 0.

$\overline{SD}$	Operating Mode
1	Unsigned Data Output
0	Signed Data Output

#### 3.1.6.4 OFMON Bit

The OFMON bit determines if the offset monitor circuit is enabled. If the OFMON bit is set to a logic '1', the offset monitor is enabled. Refer to [Section 3.8.5](#) for more information. If the OFMON bit is cleared, the offset monitor is disabled.

OFMON	Operating Mode
1	Offset Monitor Circuit Enabled
0	Offset Monitor Circuit Disabled

### 3.1.6.5 ARM Configuration Bits (A\_CFG[2:0])

The ARM Configuration Bits (A\_CFG[2:0]) select the mode of operation for the ARM/PCM pins.

**Table 9. Arming Output Configuration**

A_CFG[2]	A_CFG[1]	A_CFG[0]	Operating Mode	Output Type	Reference
0	0	0	Arm Output Disabled	Hi Impedance	
0	0	1	PCM Output	Digital Output	<a href="#">Section 3.8.10</a>
0	1	0	Moving Average Mode	Active High with Pulldown Current	<a href="#">Section 3.8.9.1</a>
0	1	1	Moving Average Mode	Active Low with Pullup Current	<a href="#">Section 3.8.9.1</a>
1	0	0	Count Mode	Active High with Pulldown Current	<a href="#">Section 3.8.9.2</a>
1	0	1	Count Mode	Active Low with Pullup Current	<a href="#">Section 3.8.9.2</a>
1	1	0	Unfiltered Mode	Active High with Pulldown Current	<a href="#">Section 3.8.9.3</a>
1	1	1	Unfiltered Mode	Active Low with Pullup Current	<a href="#">Section 3.8.9.3</a>

### 3.1.7 Axis Configuration Register (DEVCFG\_X)

The Axis configuration register is a read/write register which contains axis specific configuration information. This register can be written during initialization, but is locked once the ENDINIT bit is set. This register is included in the writable register CRC check. Refer to [Section 3.2.2](#) for details.

**Table 10. Axis Configuration Registers**

Location		Bit							
Address	Register	7	6	5	4	3	2	1	0
\$0C	DEVCFG_X	ST	Reserved	Reserved	Reserved	LPF[3]	LPF[2]	LPF[1]	LPF[0]
Reset Value		0	0	0	0	0	0	0	0

#### 3.1.7.1 Self-test Control (ST)

The ST bit enables and disables the self-test circuitry. Self-test circuitry is enabled if a logic '1' is written to ST and the ENDINIT bit has not been set. Enabling the self-test circuitry results in a positive acceleration value. Self-test deflection values are specified in [Section 2.4](#). ST is always cleared following internal reset.

When the self-test circuitry is active, the offset cancellation block and the offset monitor status are suspended, and the status bits in the Acceleration Data Request Response will indicate "Self-test Active". Reference [Section 3.8.4](#) and [Section 4.2](#) for details. When the self-test circuitry is disabled by clearing the ST bit, the offset monitor remains disabled until the time  $t_{ST\_OMB}$  specified in [Section 2.4](#) expires. However, the status bits in the Acceleration Data Request Response will immediately indicate that self-test has been deactivated.

#### 3.1.7.2 Reserved Bits (Reserved)

Bits 6 through 4 of the DEVCFG\_X register are reserved. A write to the reserved bits must always be logic '0' for normal device operation and performance.

### 3.1.7.3 Low-Pass Filter Selection Bits (LPF[3:0])

The Low Pass Filter selection bit selects a low-pass filter as shown in [Table 11](#). Refer to [Section 3.8.3](#) for details regarding filter configurations.

**Table 11. Low Pass Filter Selection Bits**

LPF[3]	LPF[2]	LPF[1]	LPF[0]	Low Pass Filter Selected	Nominal Sample Rate ( $\mu$ s)
0	0	0	0	100 Hz, 4-pole	8
0	0	0	1	300 Hz, 4-pole	8
0	0	1	0	400 Hz, 4-pole	8
0	0	1	1	800 Hz, 4-pole	8
0	1	0	0	1000 Hz, 4-pole	8
0	1	0	1	400 Hz, 3-pole	8
0	1	1	0	Reserved	Reserved
0	1	1	1	Reserved	Reserved
1	0	0	0	50 Hz, 4-pole	16
1	0	0	1	150 Hz, 4-pole	16
1	0	1	0	200 Hz, 4-pole	16
1	0	1	1	400 Hz, 4-pole	16
1	1	0	0	500 Hz, 4-pole	16
1	1	0	1	200 Hz, 3-pole	16
1	1	1	0	Reserved	Reserved
1	1	1	1	Reserved	Reserved

Note: Filter characteristics do not include g-cell frequency response.

### 3.1.8 Arming Configuration Registers (ARMCFG)

The arming configuration register contains configuration information for the arming function. The values in this register are only relevant if the arming function is operating in moving average mode, or count mode.

This register can be written during initialization but is locked once the ENDINIT bit is set. Refer to [Section 3.1.6.2](#). This register is included in the writable register CRC check. Refer to [Section 3.2.2](#) for details.

**Table 12. Arming Configuration Register**

Location		Bit							
Address	Register	7	6	5	4	3	2	1	0
\$0E	ARMCFG	Reserved	Reserved	APS[1]	APS[0]	AWS_N[1]	AWS_N[0]	AWS_P[1]	AWS_P[0]
Reset Value		0	0	0	0	1	1	1	1

#### 3.1.8.1 Reserved Bits (Reserved)

Bits 7 through 6 of the ARMCFG register are reserved. A write to the reserved bits must always be logic '0' for normal device operation and performance.



### 3.1.8.2 Arming Pulse Stretch (APS[1:0])

The APS[1:0] bit sets the programmable pulse stretch time for the arming outputs. Refer to [Section 3.8.9](#) for more details regarding the arming function.

**Table 13. Arming Pulse Stretch Definitions**

APS[1]	APS[0]	Pulse Stretch Time <sup>(1)</sup> (Typical Oscillator)
0	0	0 ms
0	1	16.256 ms to 16.384 ms
1	0	65.408 ms to 65.536 ms
1	1	261.888 ms to 262.016 ms

1. Pulse stretch times are derived from the internal oscillator, so the tolerance on this oscillator applies.

### 3.1.8.3 Arming Window Size (AWS\_x[1:0])

The AWS\_x[1:0] bit has a different function depending on the state of the A\_CFG bits in the DEVCFG register.

If the arming function is set to moving average mode, the AWS bits set the number of acceleration samples used for the arming function moving average. The number of samples is set independently for polarity. If the arming function is set to count mode, the AWS bits set the sample count limit for the arming function. The sample count limit is set independently.

Refer to [Section 3.8.9](#) for more details regarding the arming function.

**Table 14. Positive Arming Window Size Definitions (Moving Average Mode)**

AWS_P[1]	AWS_P[0]	Positive Window Size
0	0	2
0	1	4
1	0	8
1	1	16

**Table 15. Negative Arming Window Size Definitions (Moving Average Mode)**

AWS_N[1]	AWS_N[0]	Negative Window Size
0	0	2
0	1	4
1	0	8
1	1	16

**Table 16. Arming Count Limit Definitions (Count Mode)**

AWS_N[1]	AWS_N[0]	AWS_P[1]	AWS_P[0]	Sample Count Limit
Don't Care	Don't Care	0	0	1
Don't Care	Don't Care	0	1	3
Don't Care	Don't Care	1	0	7
Don't Care	Don't Care	1	1	15

### 3.1.9 Arming Threshold Registers (ARMT\_P, ARMT\_N)

These registers contain the positive and negative thresholds to be used by the arming function. Refer to [Section 3.8.9](#) for more details regarding the arming function.

These registers can be written during initialization but are locked once the ENDINIT bit is set. Refer to [Section 3.1.6.2](#). These registers are included in the writable register CRC check. Refer to [Section 3.2.2](#) for details.

**Table 17. Arming Threshold Registers**

Location		Bit							
Address	Register	7	6	5	4	3	2	1	0
\$10	ARMT_P	AT_P[7]	AT_P[6]	AT_P[5]	AT_P[4]	AT_P[3]	AT_P[2]	AT_P[1]	AT_P[0]
\$12	ARMT_N	AT_N[7]	AT_N[6]	AT_N[5]	AT_N[4]	AT_N[3]	AT_N[2]	AT_N[1]	AT_N[0]
Reset Value		0	0	0	0	0	0	0	0

The values programmed into the threshold registers are the threshold values used for the arming function as described in [Section 3.8.9](#). The threshold registers hold independent unsigned 8-bit values for polarity. Each threshold increment is equivalent to one output LSB. [Table 18](#) shows examples of some threshold register values and the corresponding threshold.

**Table 18. Threshold Register Value Examples**

Axis Type		Programmed Thresholds			
Range (g)	Sensitivity (g/LSB)	Positive (Decimal)	Negative (Decimal)	Positive Threshold (g)	Negative Threshold (g)
20	0.04097	100	50	4.10	-2.05
20	0.04097	255	0	10.45	Disabled
50	0.1024	50	20	5.12	-2.05
120	0.24414	20	10	4.88	-2.44

If either the positive or negative threshold is programmed to \$00, comparisons are disabled for only that polarity. The arming function still operates for the opposite polarity. If both the positive and negative arming thresholds are programmed to \$00, the Arming function is disabled, and the output pin is disabled, regardless of the value of the A\_CFG bits in the DEVCFG register.

### 3.1.10 Device Status Register (DEVSTAT)

The device status register is a read-only register. A read of this register clears the status flags affected by transient conditions. Reference [Section 4.5](#) for details on the MMA685x response for each status condition.

**Table 19. Device Status Register**

Location		Bit							
Address	Register	7	6	5	4	3	2	1	0
\$14	DEVSTAT	UNUSED	IDE	SDOV	DEVINIT	MISOERR	0	OFFSET	DEVRES

#### 3.1.10.1 Unused Bit (UNUSED)

The unused bit has no impact on operation or performance. When read this bit may be '1' or '0'.

#### 3.1.10.2 Internal Data Error Flag (IDE)

The internal data error flag is set if a customer or OTP register data CRC fault or other internal fault is detected as defined in [Section 4.5.5](#). The internal data error flag is cleared by a read of the DEVSTAT register. If the error is associated with a CRC fault in the writable register array, the fault will be re-asserted and will require a device reset to clear. If the error is associated with the data stored in the fuse array, the fault will be re-asserted even after a device reset.

#### 3.1.10.3 Sigma Delta Modulator Over Range Flag (SDOV)

The sigma delta modulator over range flag is set if the sigma delta modulator becomes saturated. The SDOV flag is cleared by a read of the DEVSTAT register.

### 3.1.10.4 Device Initialization Flag (DEVINIT)

The device initialization flag is set during the interval between negation of internal reset and completion of internal device initialization. DEVINIT is cleared automatically. The device initialization flag is not affected by a read of the DEVSTAT register.

### 3.1.10.5 SPI MISO Data Mismatch Error Flag (MISOERR)

The MISO data mismatch flag is set when a MISO Data mismatch fault occurs as specified in [Section 4.5.2](#). The MISOERR flag is cleared by a read of the DEVSTAT register.

### 3.1.10.6 Offset Monitor Over Range Flags (OFFSET)

The offset monitor over range flag is set if the acceleration signal reaches the specified offset limit. The offset monitor over range flags are cleared by a read of the DEVSTAT register.

### 3.1.10.7 Device Reset Flag (DEVRES)

The device reset flag is set during device initialization following a device reset. The device reset flag is cleared by a read of the DEVSTAT register.

### 3.1.11 Count Register (COUNT)

The count register is a read-only register which provides the current value of a free-running 8-bit counter derived from the primary oscillator. A 10-bit pre-scaler divides the primary oscillator frequency by 1024. Thus, the value in the register increases by one count every 128  $\mu$ s and the counter rolls over every 32.768 ms.

**Table 20. Count Register**

Location		Bit							
Address	Register	7	6	5	4	3	2	1	0
\$15	COUNT	COUNT[7]	COUNT[6]	COUNT[5]	COUNT[4]	COUNT[3]	COUNT[2]	COUNT[1]	COUNT[0]
Reset Value		0	0	0	0	0	0	0	0

### 3.1.12 Offset Correction Value Registers (OFFCORR)

The offset correction value register is a read-only register which contain the most recent offset correction increment / decrement value from the offset cancellation circuit. The value stored in this register indicates the amount of offset correction being applied to the SPI output data. The values have a resolution of 1 LSB.

**Table 21. Offset Correction Value Register**

Location		Bit							
Address	Register	7	6	5	4	3	2	1	0
\$16	OFFCORR_X	OFFCORR_X[7]	OFFCORR_X[6]	OFFCORR_X[5]	OFFCORR_X[4]	OFFCORR_X[3]	OFFCORR_X[2]	OFFCORR_X[1]	OFFCORR_X[0]
Reset Value		0	0	0	0	0	0	0	0

### 3.1.13 Reserved Registers (Reserved)

Registers \$1C and \$1D are reserved. A write to the reserved bits must always be logic '0' for normal device operation and performance.

**Table 22. Reserved Registers**

Location		Bit							
Address	Register	7	6	5	4	3	2	1	0
\$1C	Reserved	Reserved	Reserved	Reserved	Reserved	Reserved	Reserved	Reserved	Reserved
\$1D	Reserved	Reserved	Reserved	Reserved	Reserved	Reserved	Reserved	Reserved	Reserved
Reset Value		0	0	0	0	0	0	0	0

## **3.2 Customer Accessible Data Array CRC Verification**

### **3.2.1 OTP Shadow Register Array CRC Verification**

The OTP shadow register array is verified for errors using a 3-bit CRC. The CRC verification uses a generator polynomial of  $g(x) = X^3 + X + 1$ , with a seed value = '111'. If a CRC error is detected in the OTP array, the IDE bit is set in the DEVSTAT register.

### **3.2.2 Writable Register CRC Verification**

The writable registers in the data array are verified for errors using a 3-bit CRC. The CRC verification is enabled only when the ENDINIT bit is set in the DEVCFG register. The CRC verification uses a generator polynomial of  $g(x) = X^3 + X + 1$ , with a seed value = '111'. If a CRC error is detected in the writable register array, the IDE bit is set in the DEVSTAT register.

### 3.3 Voltage Regulators

Separate internal voltage regulators supply the analog and digital circuitry. External filter capacitors are required, as shown in Figure 1. The voltage regulator module includes voltage monitoring circuitry which indicates a device reset until the external supply and all internal regulated voltages are within predetermined limits. A reference generator provides a stable voltage which is used by the  $\Sigma\Delta$  converters.

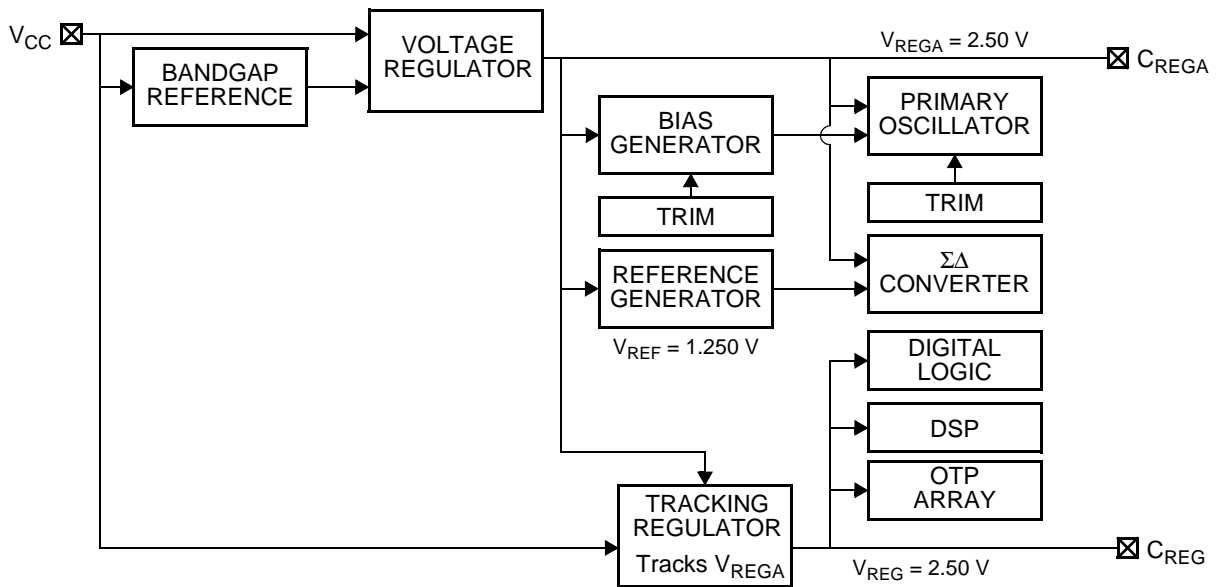

Figure 8. Power Supply

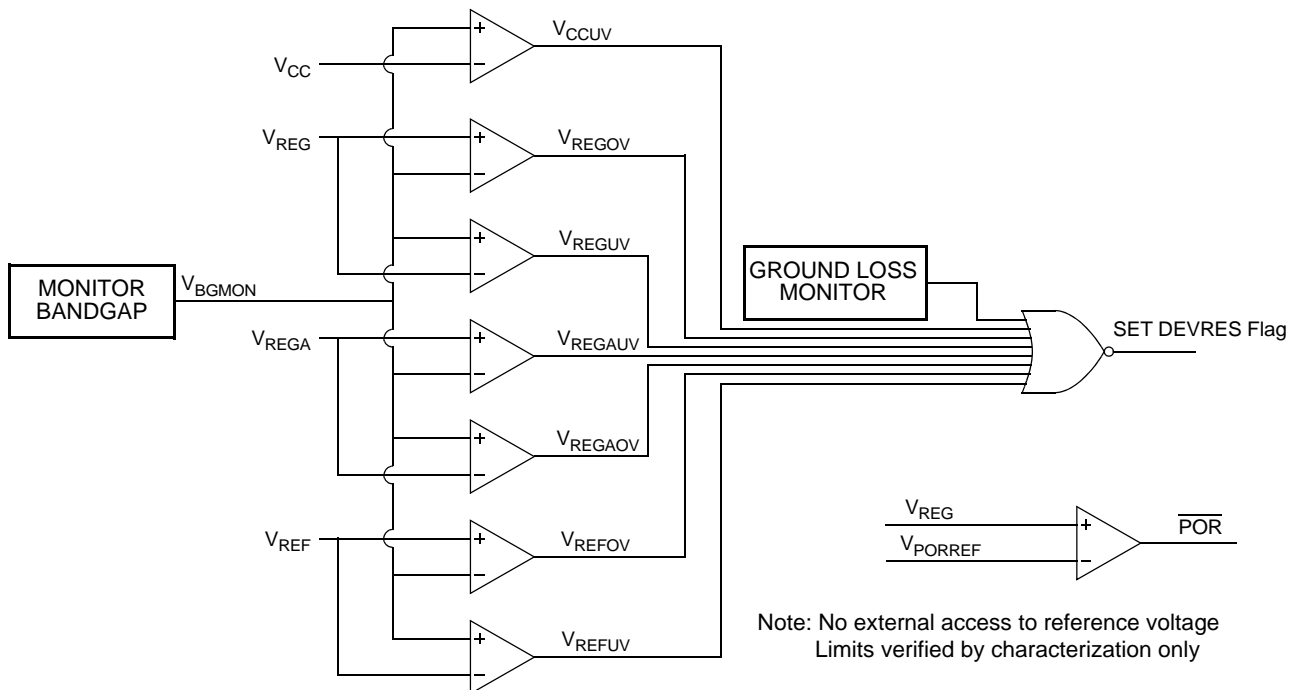

Figure 9. Voltage Monitoring

### 3.3.1 C<sub>REG</sub> Failure Detection

The digital supply voltage regulator is designed to be unstable with low capacitance. If the connection to the V<sub>REG</sub> capacitor becomes open, the digital supply voltage will oscillate and cause either an undervoltage, or overvoltage failure within one internal sample time. This failure will result in one of the following:

1. The DEVRES flag in the DEVSTAT register will be set. MMA685x will respond to SPI acceleration requests as defined in [Table 27](#).
2. MMA685x will be held in RESET and be non-responsive to SPI requests.

### 3.3.2 C<sub>REGA</sub> Failure Detection

The analog supply voltage regulator is designed to be unstable with low capacitance. If the connection to the V<sub>REGA</sub> capacitor becomes open, the analog supply voltage will oscillate and cause either an undervoltage, or overvoltage failure within one internal sample time. The DEVRES flag in the DEVSTAT register will be set. MMA685x will respond to SPI acceleration requests as defined in [Table 27](#).

**Note:** This feature is only supported with a V<sub>CC</sub> supply voltage in the range of 4.75 V to 5.25 V.

### 3.3.3 V<sub>SS</sub> and V<sub>SSA</sub> Ground Loss Monitor

MMA685x detects the loss of ground connection to either V<sub>SS</sub> or V<sub>SSA</sub>. A loss of ground connection to V<sub>SS</sub> will result in a V<sub>REG</sub> overvoltage failure. A loss of ground connection to V<sub>SSA</sub> will result in a V<sub>REG</sub> undervoltage failure. Both failures result in a device reset.

### 3.3.4 SPI Initiated Reset

In addition to voltage monitoring, a device reset can be initiated by a specific series of three write operations involving the RES\_1 and RES\_0 bits in the DEVCTL register. Reference [Section 3.1.5.1](#) for details regarding the SPI initiated reset.

## 3.4 Internal Oscillator

MMA685x includes a factory trimmed oscillator as specified in [Section 2.6](#).

### 3.4.1 Oscillator Monitor

The COUNT register in the customer accessible array is a read-only register which provides the current value of a free-running 8-bit counter derived from the primary oscillator. A 10-bit pre-scaler divides the primary oscillator by 1024. Thus, the value in the COUNT register increases by one count every 128 μs, and the register rolls over every 32.768 ms. The SPI master can periodically read the COUNT register, and verify the difference between subsequent register reads against the system time base.

1. The SPI access rates and deviations must be taken into account for this oscillator verification.

### 3.5 Transducer

The MMA685x transducer is an overdamped mass-spring-damper system described by the following transfer function:

$$H(s) = \frac{\omega_n^2}{s^2 + 2 \cdot \zeta \cdot \omega_n \cdot s + \omega_n^2}$$

where:

$\zeta$  = Damping Ratio

$\omega_n$  = Natural Frequency =  $2 \cdot \Pi \cdot f_n$

Reference [Section 2.4](#) for transducer parameters.

### 3.6 Self-test Interface

The self-test interface applies a voltage to the *g*-cell, causing deflection of the proof mass. The self-test interface is controlled through SPI write operations to the DEVCFG\_X register described in [Section 3.1.7](#). The ENDINIT bit in the DEVCFG register must also be low to enable self-test. A diagram of the self-test interface is shown in [Figure 10](#).

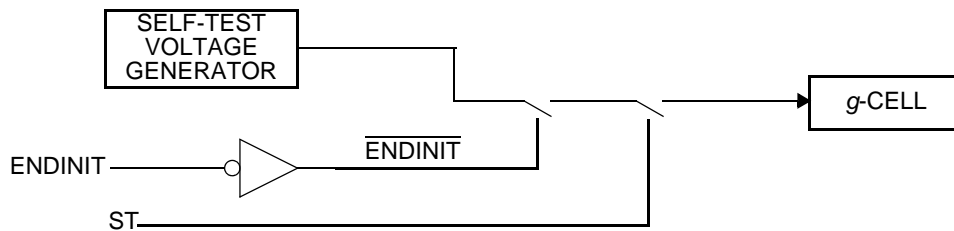

**Figure 10. Self-test Interface**

The raw self-test deflection can be verified against raw self-test limits using the following equations:

$$\Delta ST_{MINLIMIT} = FLOOR \cdot (\Delta ST_{MIN}) \cdot [SENS \cdot (1 - \Delta SENS)]$$

$$\Delta ST_{MAXLIMIT} = CEIL \cdot (\Delta ST_{MAX}) \cdot [SENS \cdot (1 + \Delta SENS)]$$

where:

$\Delta ST_{MIN}$	The minimum self-test deflection over temperature as specified in <a href="#">Section 2.4</a> .
$\Delta ST_{MAX}$	The maximum self-test deflection over temperature as specified in <a href="#">Section 2.4</a> .
SENS	The sensitivity of the device
$\Delta SENS$	The sensitivity tolerance

### 3.7 $\Sigma\Delta$ Converters

Two sigma delta converters provide the interface between the g-cell and the DSP. The output of each  $\Sigma\Delta$  converter is a data stream at a nominal frequency of 1 MHz.

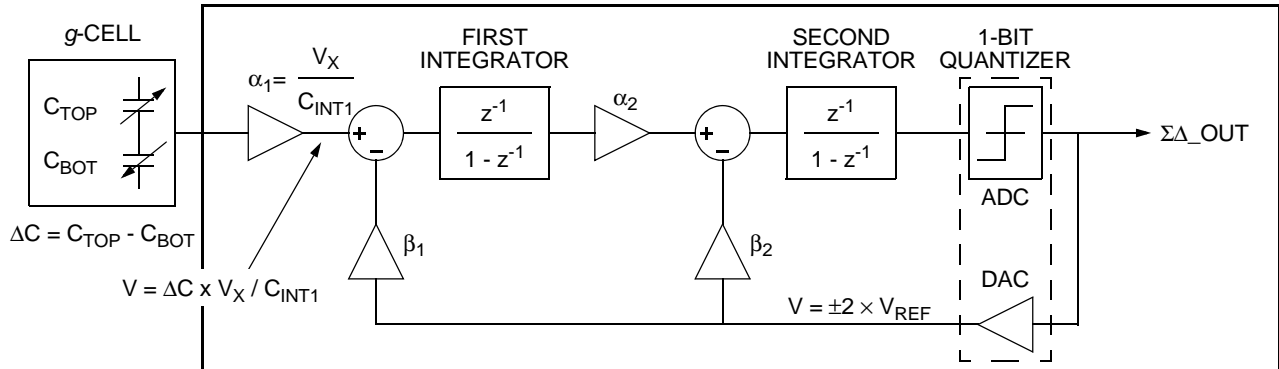

Figure 11.  $\Sigma\Delta$  Converter Block Diagram

### 3.8 Digital Signal Processing Block

A digital signal processing (DSP) block is used to perform signal filtering and compensation operations. A diagram illustrating the signal processing flow is shown in Figure 12.

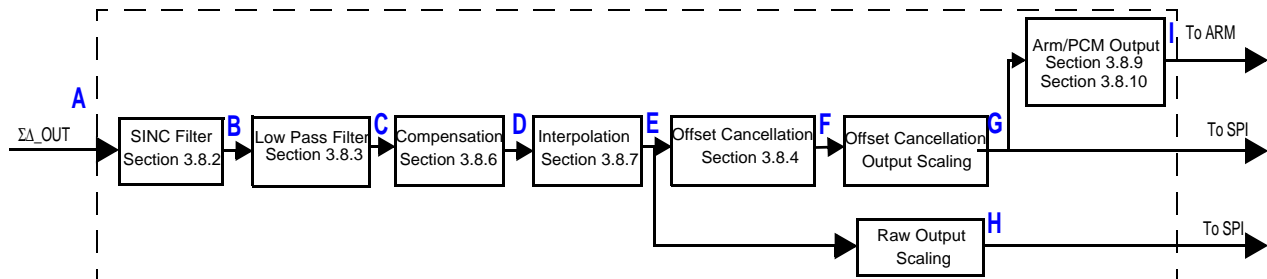

Figure 12. Signal Chain Diagram

Table 23. MMA685x Signal Chain Characteristics

	Description	Sample Time ( $\mu\text{s}$ )	Data Width Bits	Over Bits	Effective Bits	Rounding Resolution Bits	Typical Block Latency	Reference
A	$\Sigma\Delta$	1	1		1	—	3.2 $\mu\text{s}$	Section 3.7
B	SINC Filter	8	14		13	—	11.2 $\mu\text{s}$	Section 3.8.2
C	Low Pass Filter	8/16	20	6	10	4	Reference Section 3.8.3	Section 3.8.3
D	Compensation	8/16	20	6	10	4	7.875 $\mu\text{s}$	Section 3.8.6
E	Interpolation	4/8	20	6	10	4	$t_s / 2$	Section 3.8.7
F	Offset Cancellation	256	20	6	10	4	N/A	Section 3.8.4
G, H	SPI Output	4/8	—	—	10	—	$t_s / 2$	—
I	PCM Output	4/8	—	—	9	—	—	Section 3.8.10



### 3.8.1 DSP Clock

The DSP is clocked at 8 MHz, with an effective 6MHz operating frequency. The clock to the DSP is disabled for 1 clock prior to each edge of the  $\Sigma\Delta$  modulator clock to minimize noise during data conversion. The bit streams from the two  $\Sigma\Delta$  converters are processed through independent data paths within the DSP.

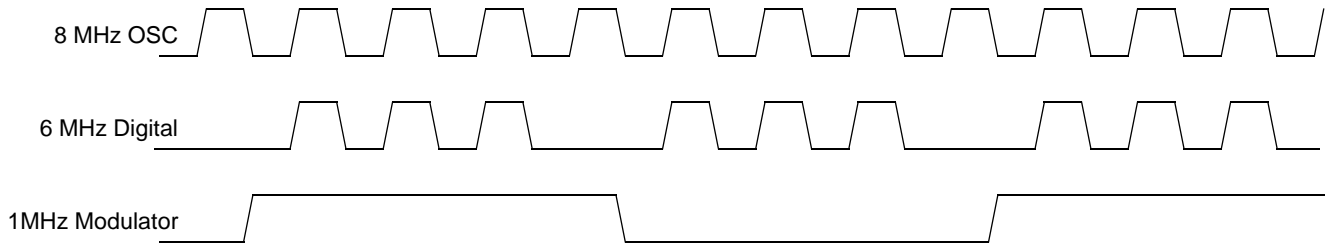

Figure 13. Clock Generation

### 3.8.2 Decimation Sinc Filter

The serial data stream produced by the  $\Sigma\Delta$  converter is decimated and converted to parallel values by a 3rd order 16:1 sinc filter with a decimation factor of 8 or 16, depending on the Low Pass Filter selected.

$$H(z) = \left[ \frac{1 - z^{-16}}{16(1 - z^{-1})} \right]^3$$

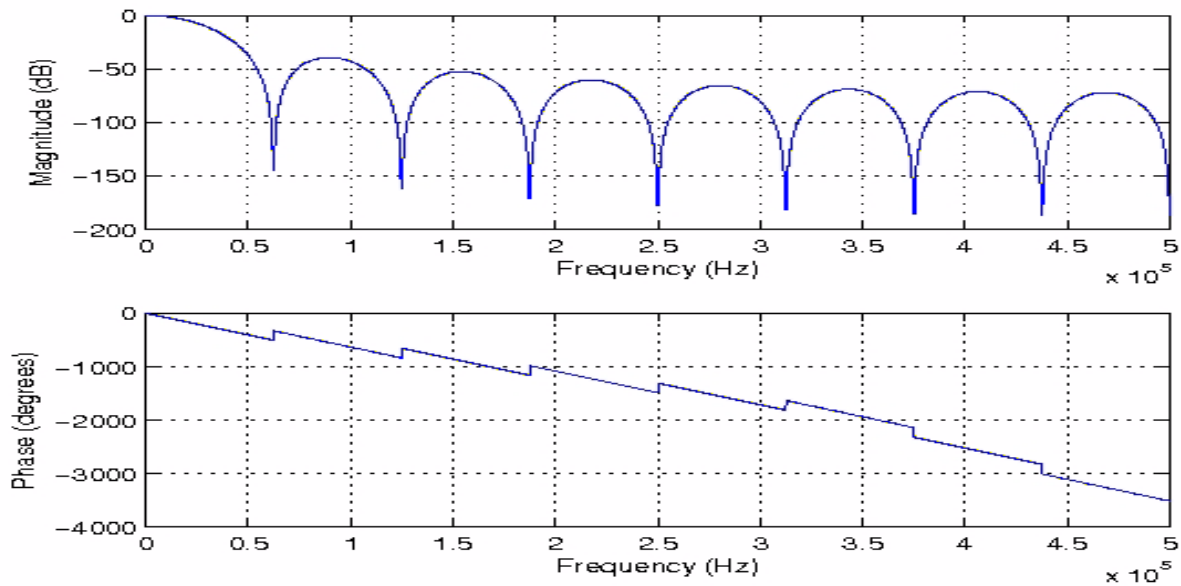

Figure 14. Sinc Filter Response,  $t_s = 8 \mu$ s

### 3.8.3 Low Pass Filter

Data from the Sinc filter is processed by an infinite impulse response (IIR) low pass filter.

$$H(z) = \frac{n_0 + (n_1 \cdot z^{-1}) + (n_2 \cdot z^{-2}) + (n_3 \cdot z^{-3}) + (n_4 \cdot z^{-4})}{d_0 + (d_1 \cdot z^{-1}) + (d_2 \cdot z^{-2}) + (d_3 \cdot z^{-3}) + (d_4 \cdot z^{-4})}$$

MMA685x provides the option for one of twelve low-pass filters. The filter is selected with the LPF[3:0] bits in the DEVCFG\_X register. The filter selection options are listed in [Section 3.1.7.3, Table 11](#). Response parameters for the low-pass filter are specified in [Section 2.4](#). Filter characteristics are illustrated in [Figures 15, 16, 17, 18, 19](#) and [20](#).

**Table 24. Low Pass Filter Coefficients**

Description	Sample Time (μs)	Filter Coefficients				Group Delay
50 Hz LPF	16	n <sub>0</sub>	2.08729034056887e-10	d <sub>0</sub>	1	26816/f <sub>osc</sub>
		n <sub>1</sub>	8.349134489240434e-10	d <sub>1</sub>	-3.976249694824219	
		n <sub>2</sub>	1.25237777794924e-09	d <sub>2</sub>	5.929003009577855	
		n <sub>3</sub>	8.349103355433541e-10	d <sub>3</sub>	-3.929255528257727	
100 Hz LPF	8	n <sub>4</sub>	2.087307211059861e-10	d <sub>4</sub>	0.9765022168437554	
		n <sub>0</sub>	1.639127731323242e-08	d <sub>0</sub>	1	9024/f <sub>osc</sub>
150 Hz LPF	16	n <sub>1</sub>	6.556510925292969e-08	d <sub>1</sub>	-3.928921222686768	
		n <sub>2</sub>	9.834768482194806e-08	d <sub>2</sub>	5.789028996785419	
		n <sub>3</sub>	6.556510372902331e-08	d <sub>3</sub>	-3.791257019240902	
300 Hz LPF	8	n <sub>4</sub>	1.639128257923422e-08	d <sub>4</sub>	0.9311495074496179	
		200 Hz LPF	16	n <sub>0</sub>	5.124509334564209e-08	d <sub>0</sub>
n <sub>1</sub>	2.049803733825684e-07			d <sub>1</sub>	-3.905343055725098	
n <sub>2</sub>	3.074705789151505e-07			d <sub>2</sub>	5.72004239520561	
n <sub>3</sub>	2.049803958150164e-07			d <sub>3</sub>	-3.723967810019985	
400 Hz LPF	8	n <sub>4</sub>	5.124510693742625e-08	d <sub>4</sub>	0.9092692903507213	
		200 Hz LPF 3-pole	16	n <sub>0</sub>	2.720393240451813e-06	d <sub>0</sub>
n <sub>1</sub>	8.161179721355438e-06			d <sub>1</sub>	-2.931681632995605	
n <sub>2</sub>	8.161180123840722e-06			d <sub>2</sub>	2.865296718275204	
n <sub>3</sub>	2.720393634345496e-06			d <sub>3</sub>	-0.9335933215174919	
400 Hz LPF 3-pole	8	n <sub>4</sub>	0	d <sub>4</sub>	0	
		400 Hz LPF	16	n <sub>0</sub>	7.822513580322266e-07	d <sub>0</sub>
n <sub>1</sub>	3.129005432128906e-06			d <sub>1</sub>	-3.811614513397217	
n <sub>2</sub>	4.693508163398543e-06			d <sub>2</sub>	5.450666051045118	
n <sub>3</sub>	3.129005428784364e-06			d <sub>3</sub>	-3.465805771100349	
800 Hz LPF	8	n <sub>4</sub>	7.822513604678875e-07	d <sub>4</sub>	0.8267667478030489	
		500 Hz LPF	16	n <sub>0</sub>	1.865386962890625e-06	d <sub>0</sub>
n <sub>1</sub>	7.4615478515625e-06			d <sub>1</sub>	-3.765105724334717	
n <sub>2</sub>	1.119232176112846e-05			d <sub>2</sub>	5.319861050818872	
n <sub>3</sub>	7.4615478515625e-06			d <sub>3</sub>	-3.34309015036024	
1000 Hz LPF	8	n <sub>4</sub>	1.865386966264658e-06	d <sub>4</sub>	0.7883646729233078	

Note: Low Pass Filter Figures do not include g-cell frequency response.

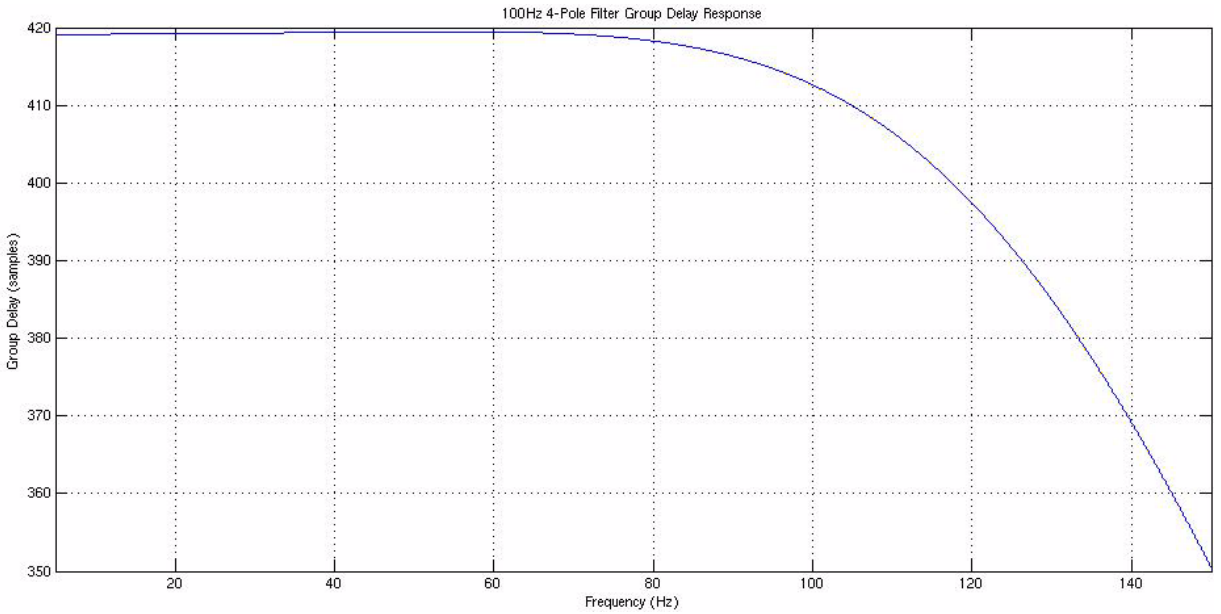
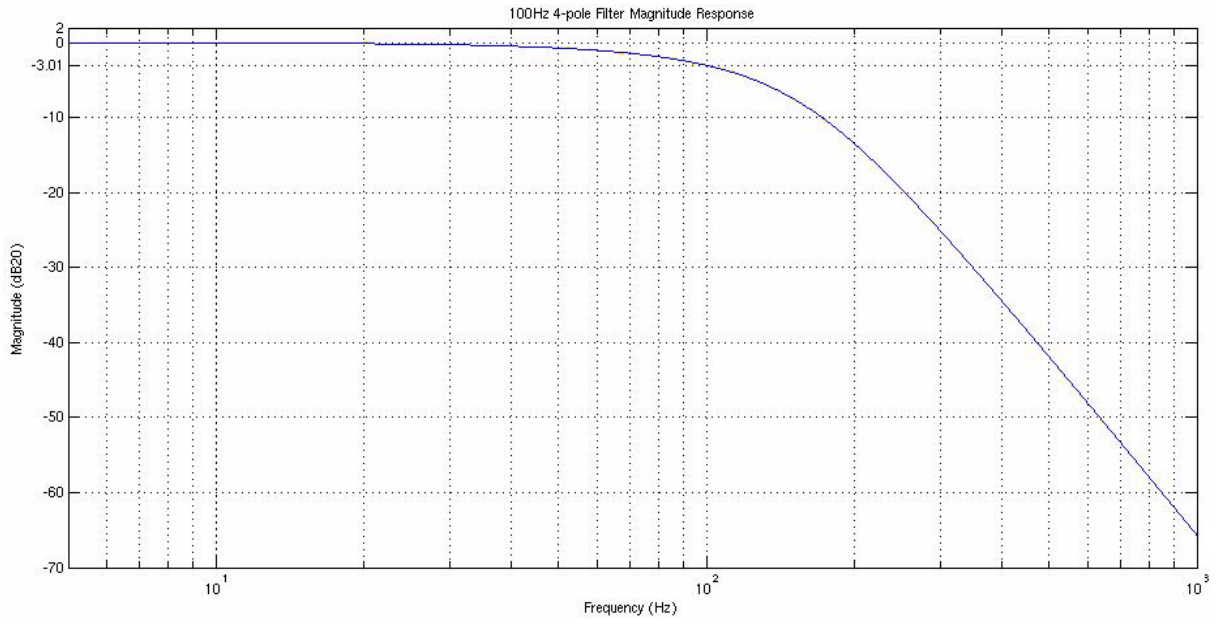

**Figure 15. Low-Pass Filter Characteristics:  $f_C = 100$  Hz, Poles = 4,  $t_S = 8 \mu s$**

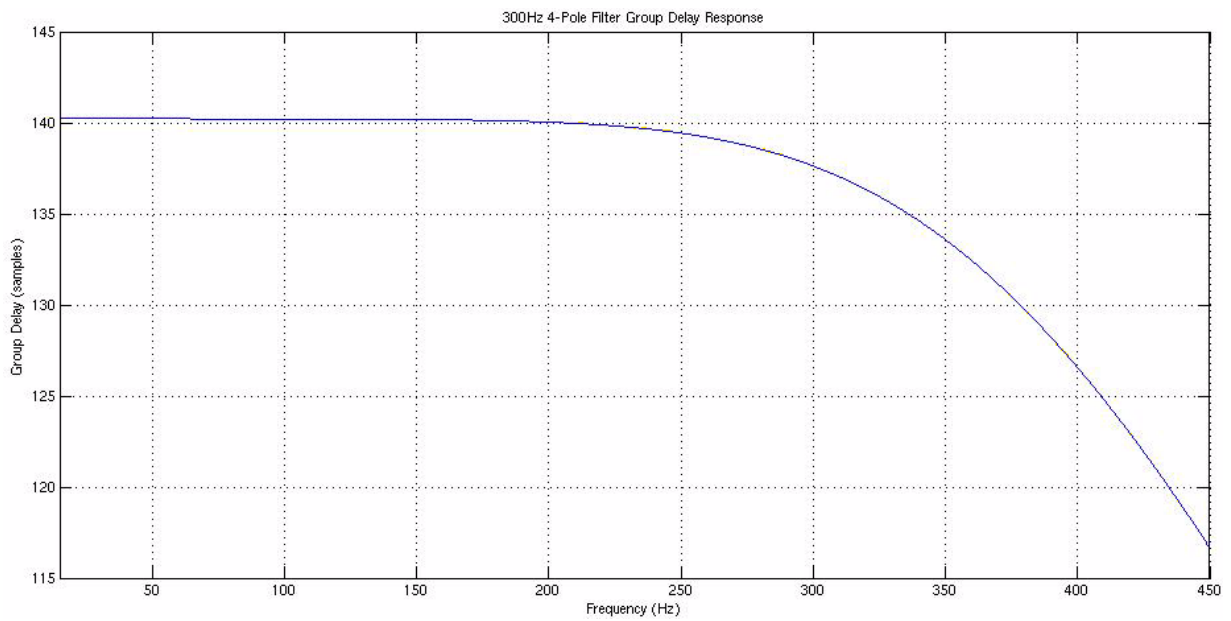
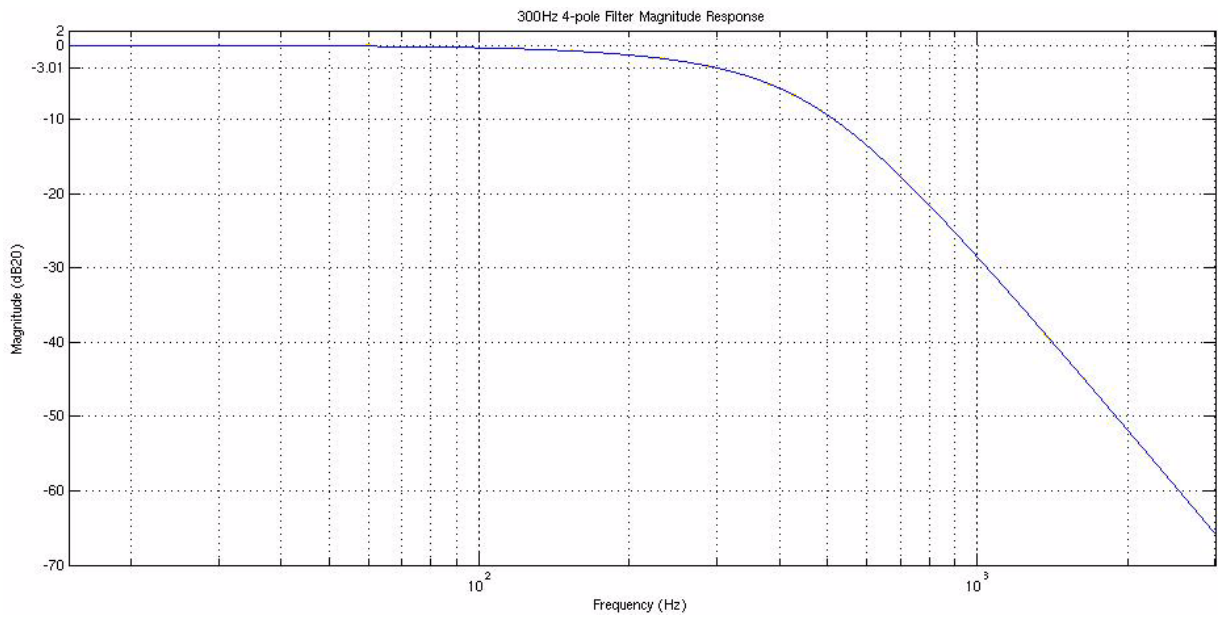

**Figure 16. Low-Pass Filter Characteristics:  $f_C = 300$  Hz, Poles = 4,  $t_S = 8 \mu s$**

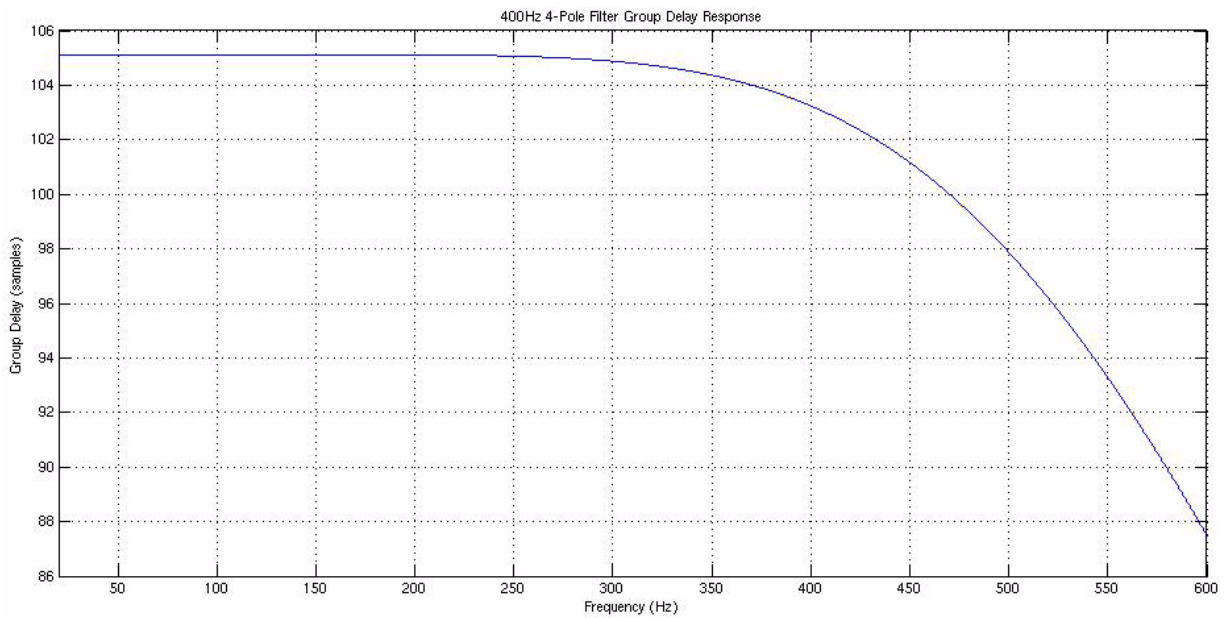
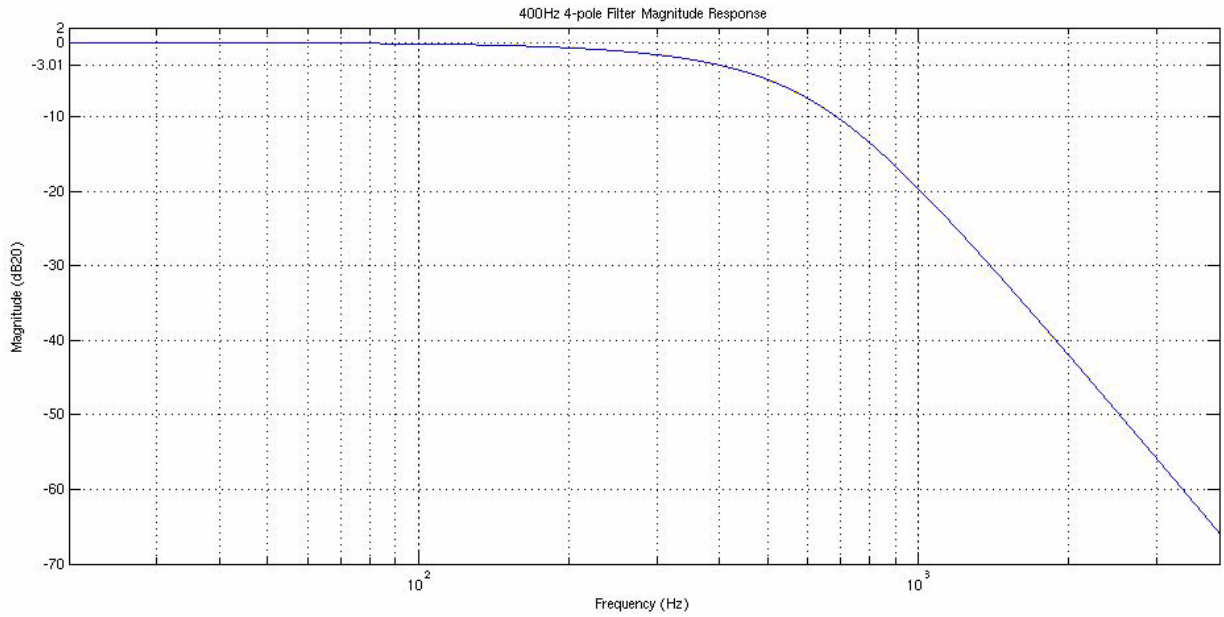

**Figure 17. Low-Pass Filter Characteristics:  $f_C = 400$  Hz, Poles = 4,  $t_S = 8 \mu s$**

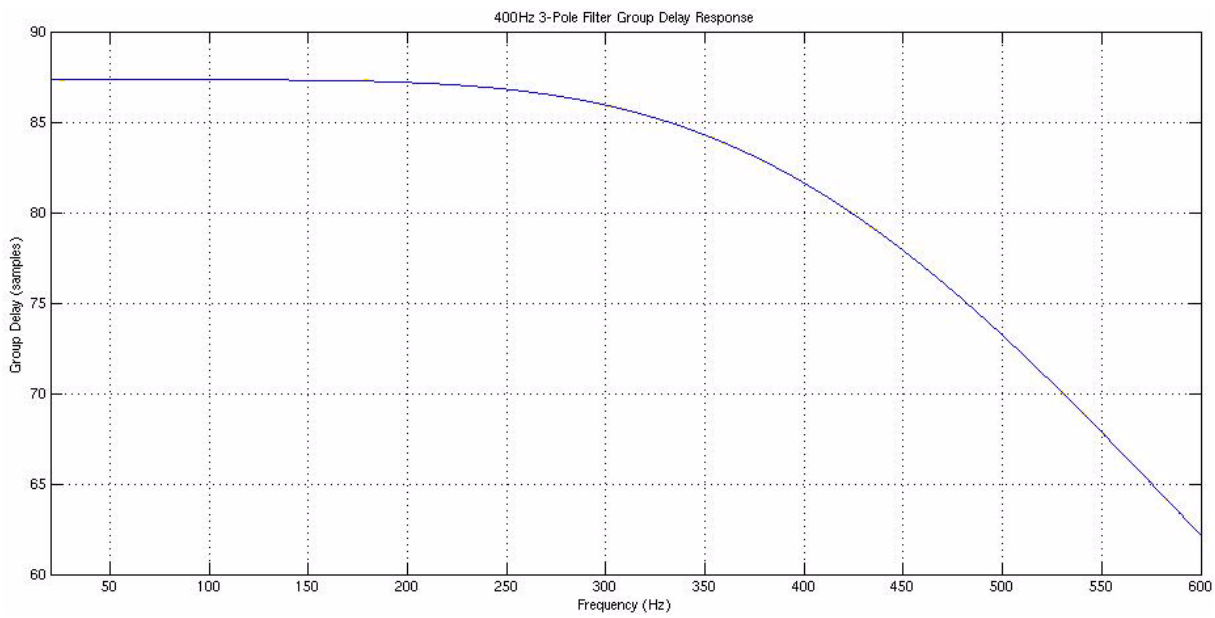
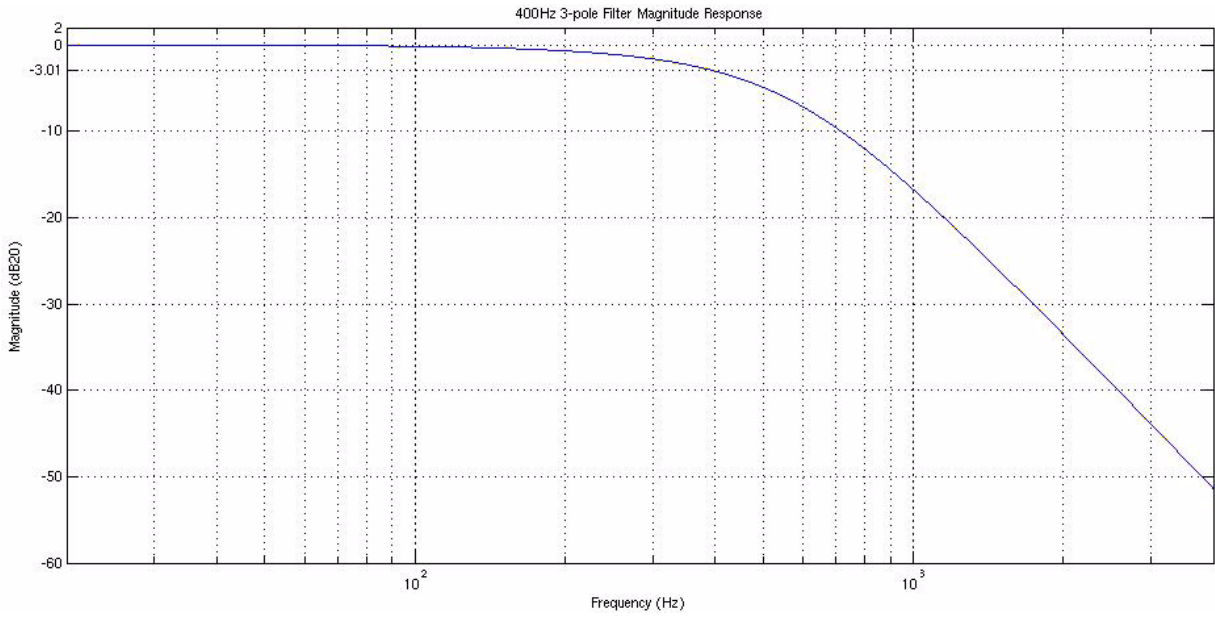

**Figure 18. Low-Pass Filter Characteristics:  $f_C = 400$  Hz, Poles = 3,  $t_S = 8 \mu s$**

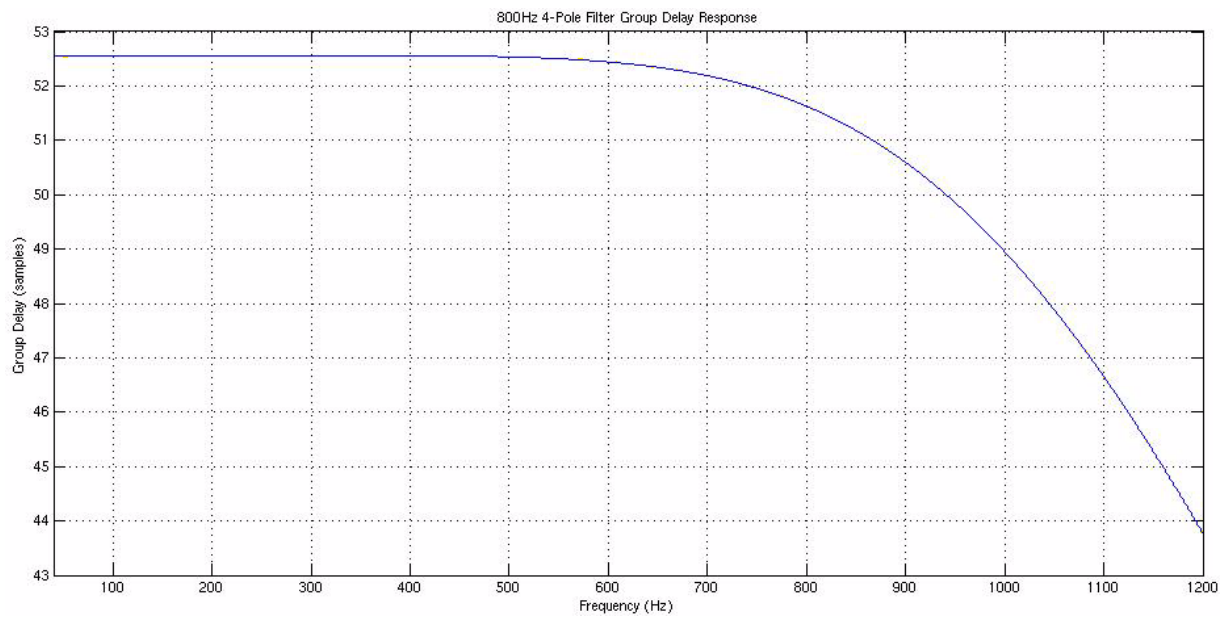
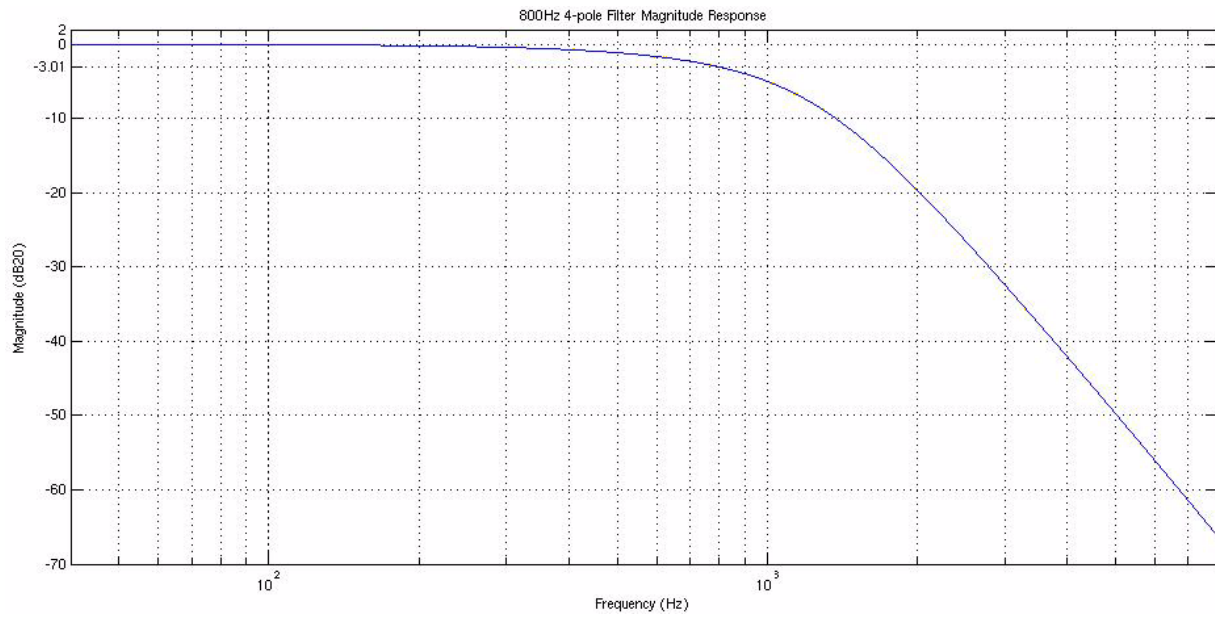

**Figure 19. Low-Pass Filter Characteristics:  $f_C = 800$  Hz, Poles = 4,  $t_S = 8 \mu s$**

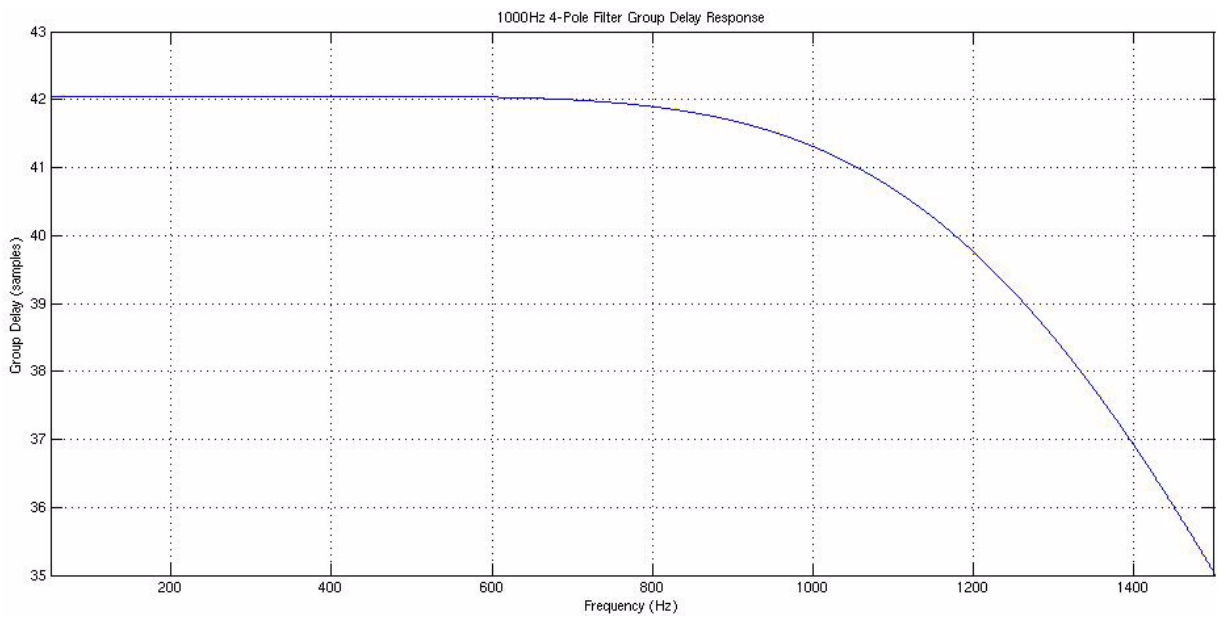
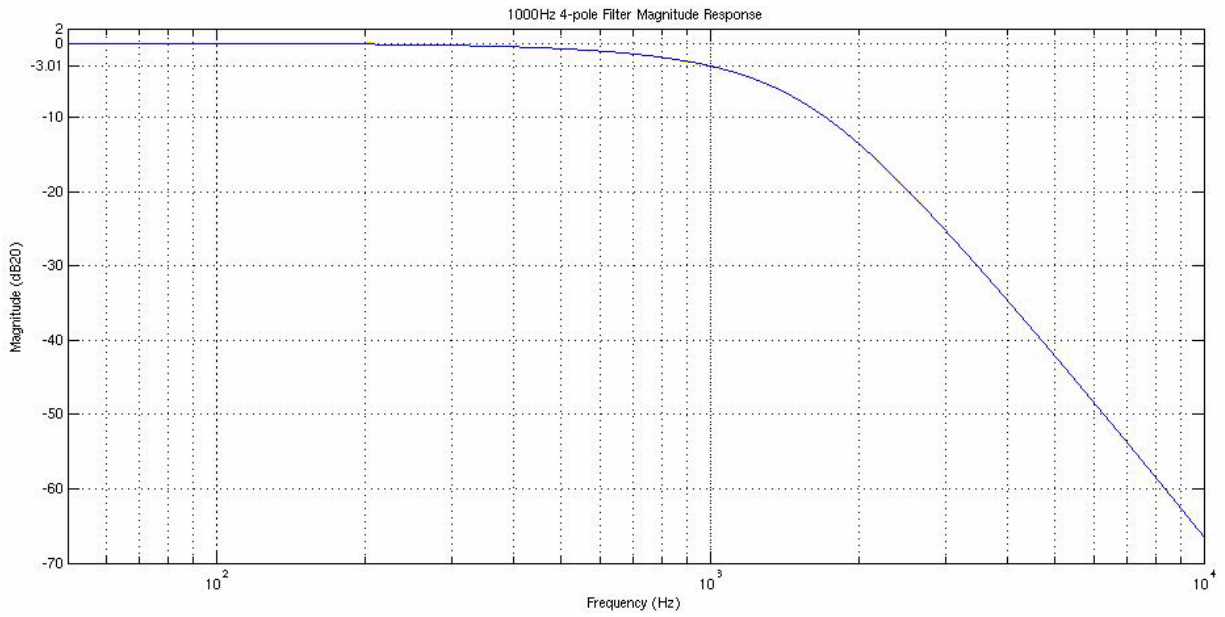

Figure 20. Low-Pass Filter Characteristics:  $f_C = 1000$  Hz, Poles = 4,  $t_S = 8 \mu s$



### 3.8.4 Offset Cancellation

MMA685x provides the option to read offset cancelled acceleration data via the SPI by clearing the  $\overline{OC}$  bit in the SPI command (reference Section 4.1). A block diagram of the offset cancellation is shown in Figure 21, and response parameters are specified in Section 2.4 and in Table 25.

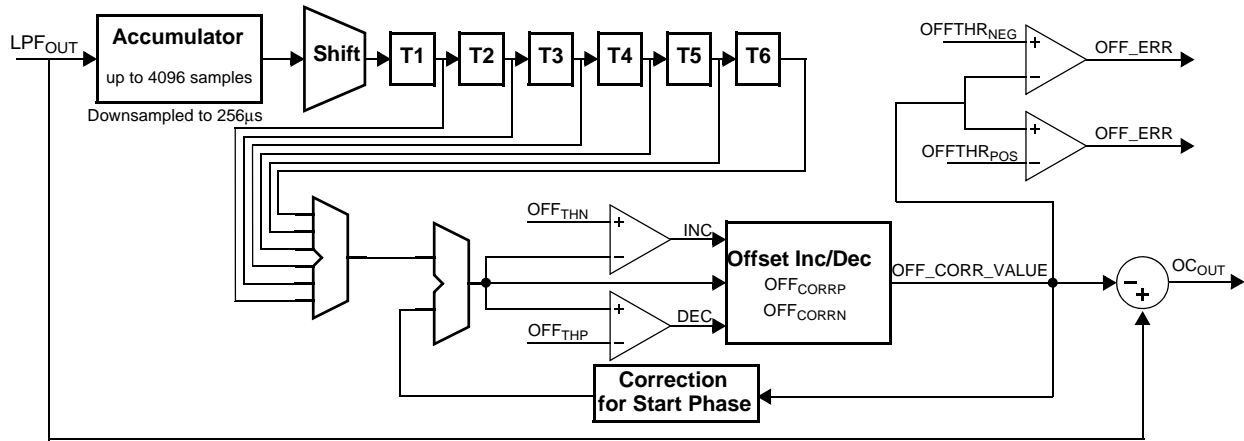

Figure 21. Offset Cancellation Block Diagram

In normal operation, the offset cancellation circuit computes a 24,576 sample running average of the acceleration data downsampled to 256  $\mu$ s. The running average is compared against positive and negative thresholds to determine the offset correction value that will be applied to the acceleration data.

During start up, three phases of moving average sizes are used to allow for faster convergence of misuse input signals. Refer to Table 25 for offset cancellation timing information during startup and normal operation.

Table 25. Offset Cancellation Timing Specifications

Phase	Start Time of Phase (from POR)	Typical Time in Phase (ms)	# of Samples in Phase	Samples Averaged	OFF_CORR_VALUE Update Rate (ms)	Averaging Period (ms)	Maximum Slew Rate (LSB/s)	Averaging Filter -3 dB Frequency (Hz)
Start 1	$t_{OP}$	524.288	2048	48	2.048	12.288	122.1	36.05
Start 2	$t_{OP} + 524.288$	524.288	2048	384	16.38	98.304	15.26	4.506
Start 3	$t_{OP} + 1048.576$	524.288	2048	3072	131.1	786.432	1.907	0.5632
Normal	$t_{OP} + 1572.864$	—	—	24576	1049	6291.456	0.2384	0.07040

When the self-test circuitry is active, the offset cancellation block and the offset monitor block are suspended, and the offset correction value is constant. Once the self-test circuitry is disabled, the offset cancellation block remains suspended for the time  $t_{ST\_OMB}$  to allow the acceleration output to return to its nominal offset.

### 3.8.5 Offset Monitor

MMA685x provides the option for an offset monitor circuit. The offset monitor circuit is enabled when the OFMON bit in the DEVCFG register is programmed to a logic '1'. The output of the offset cancellation circuit is compared against a high and low threshold. If the offset correction value exceeds either the  $OFFTHR_{POS}$ , or  $OFFTHR_{NEG}$  threshold, an Offset Over Range condition is indicated.

The offset correction value update rate is listed in Table 25. Because the offset monitor uses this value, the offset monitor will also update at this rate. The time to indicate an Offset Over Range is dependent upon the input signal.

The offset monitor status remains frozen during self-test, because the offset monitor is based on the offset cancellation circuit, which is also suspended during self-test. The offset monitor is disabled for 2.1 seconds following reset regardless of the state of the OFMON bit.

### 3.8.6 Signal Compensation

MMA685x includes internal OTP and signal processing to compensate for sensitivity error and offset error. This compensation is necessary to achieve the specified parameters in Section 2.4.

### 3.8.7 Data Interpolation

MMA685x includes 2 to 1 data interpolation to minimize the system sample jitter. Each result produced by the digital signal processing chain is delayed one half of a sample time, and the interpolated value of successive samples is provided between sample times. This operation is illustrated in Figure 22.

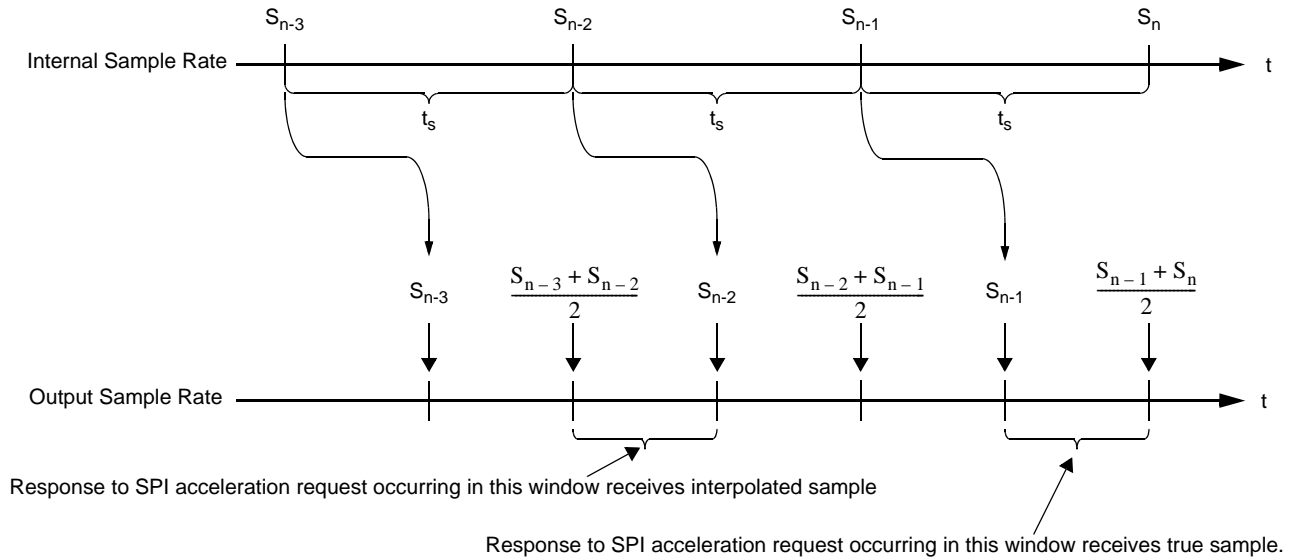

**Figure 22. Data Interpolation Timing**

The effect of this interpolation at the system level is a 50 % reduction in sample jitter. Figure 23 shows the resulting output data for an input signal.

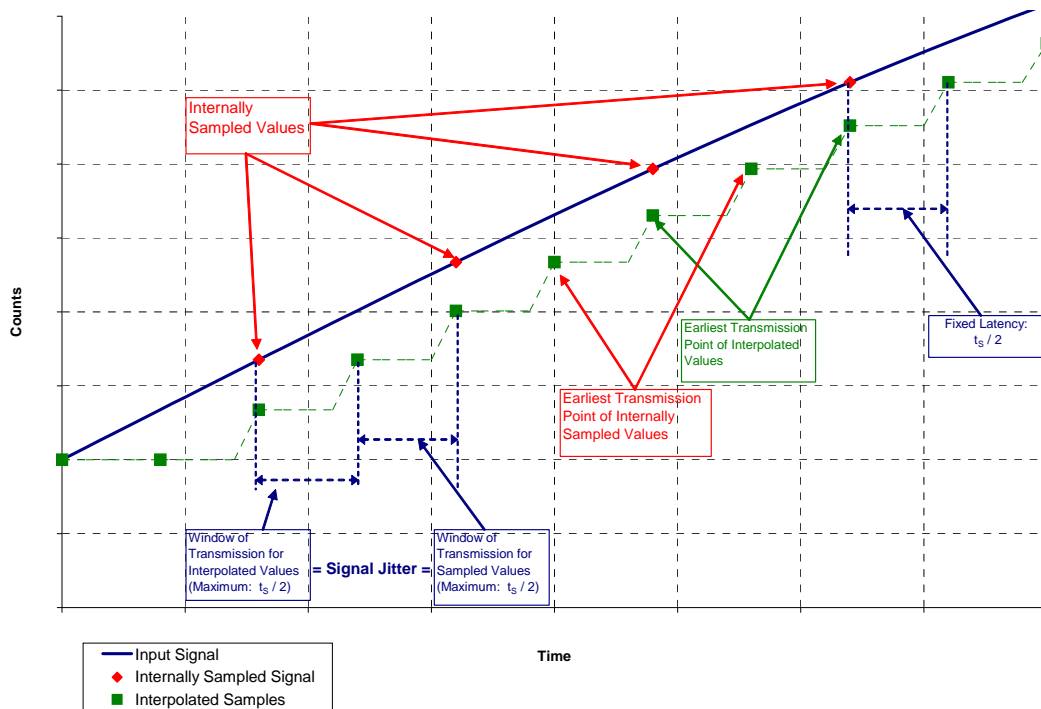

**Figure 23. Data Interpolation Example**

### 3.8.8 Acceleration Data Timing

The MMA685x SPI uses a request/response protocol, where a SPI transfer is completed through a sequence of two phases. Reference [Section 4](#) for more details regarding the SPI protocol. In order to provide the most recent acceleration data for each request, MMA685x latches the associated data for an acceleration request at the falling edge of  $\overline{CS}$  for the acceleration response message (the subsequent SPI transfer). The most recent sample available from the DSP (including interpolation), is latched, providing a maximum latency of  $1 * t_s$  relative to the falling edge of  $\overline{CS}$ .

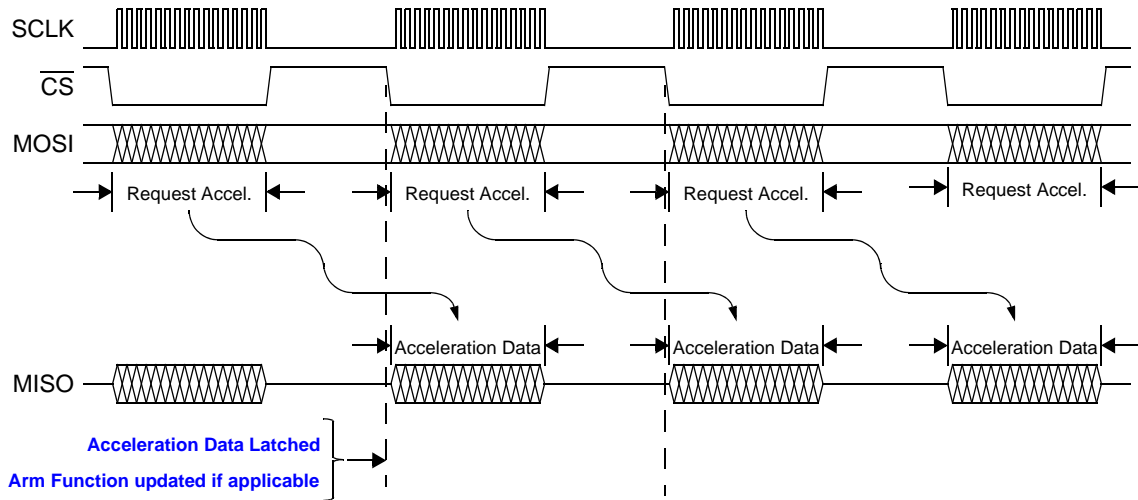

Figure 24. Acceleration Data Timing

### 3.8.9 Arming Function

MMA685x provides the option for an arming function with three modes of operation. The operation of the arming function is selected by the state of the A\_CFG bits in the DEVCFG register.

Reference [Section 4.5](#) for the operation of the Arming function with exception conditions. Error conditions do not impact prior arming function responses. If an error occurs after an arming activation, the corresponding pulse stretch for the existing arming condition will continue. However, new acceleration reads will not update the arming function regardless of the acceleration value.

#### 3.8.9.1 Arming Function: Moving Average Mode

In moving average mode, the arming function runs a moving average on the offset cancelled output. The number of samples used for the moving average (k) is programmable via the AWS\_x[1:0] bits in the ARMCFGX register. Reference [Section 3.1.8](#) for register details.

$$ARM\_MA_n = (OC_n + OC_{n-1} + \dots + OC_{n+1-k})/k$$

Where n is the current sample.

The sample rate is determined by the SPI acceleration data sample rate. At the falling edge of  $\overline{CS}$  for an acceleration data SPI response, the moving average is updated with a new sample. Reference [Figure 27](#). The SPI acceleration data sample rate must meet the minimum time between requests ( $t_{ACC\_REQ\_x}$ ) specified in [Section 2.5](#).

The moving average output is compared against positive and negative 8-bit thresholds that are programmed via the ARMT\_x registers. Reference [Section 3.1.9](#) for register details. If the moving average equals or exceeds either threshold, an arming condition is indicated, the ARM output is asserted, and the pulse stretch counter is set as described in [Section 3.8.9.4](#).

The ARM output is de-asserted only when the pulse stretch counter expires. [Figure 27](#) shows the arming output operation for different SPI conditions.

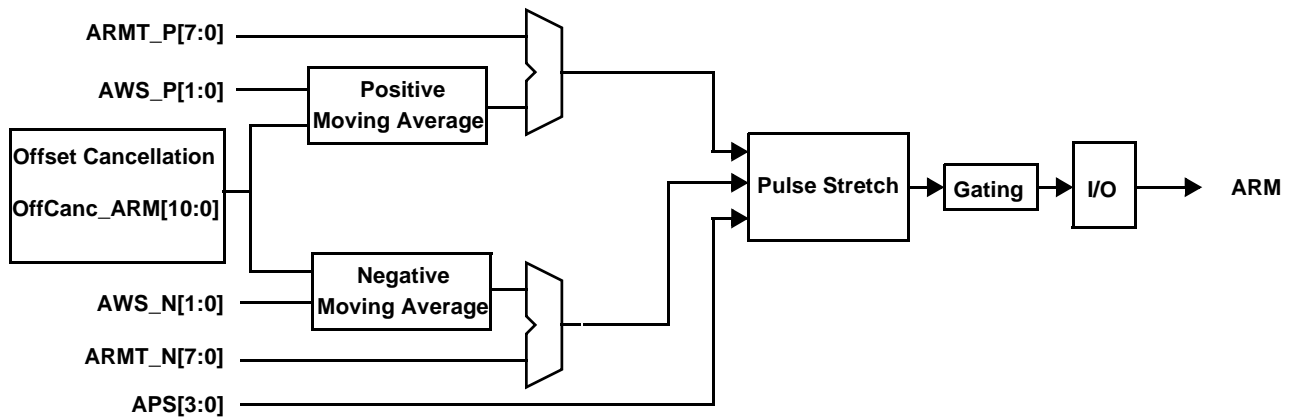

Figure 25. Arming Function Block Diagram - Moving Average Mode

### 3.8.9.2 Arming Function: Count Mode

In count mode, the arming function compares each input sample against positive and negative thresholds that are programmed via the ARMT\_x registers. Reference [Section 3.1.9](#) for register details. If the sample equals or exceeds either threshold, a sample counter is incremented. If the sample does not exceed either threshold, the sample counter is reset to zero.

The sample rate is determined by the SPI acceleration data sample rate. At the falling edge of  $\overline{CS}$  for an acceleration data SPI response, a new sample is compared against the thresholds. Reference [Figure 27](#). The SPI acceleration data sample rate must meet the minimum time between requests ( $t_{ACC\_REQ\_x}$ ) specified in [Section 2.5](#).

A sample count limit is programmable via the AWS\_x[1:0] bits in the ARMCFG register. If the sample count reaches the programmable sample count limit, an arming condition is indicated, the ARM output is asserted and the pulse stretch counter is set as described in [Section 3.8.9.4](#).

The ARM output is de-asserted only when the pulse stretch counter expires. [Figure 27](#) shows the arming output operation for different SPI conditions.

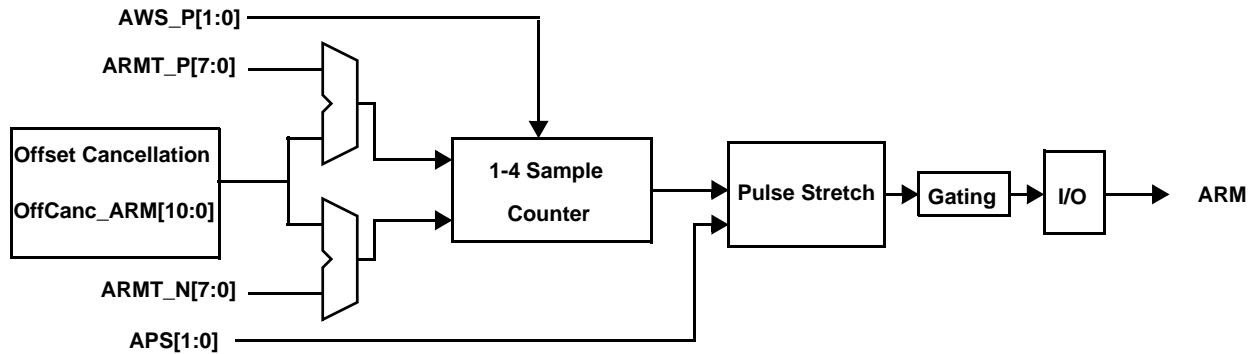

Figure 26. Arming Function Block Diagram - Count Mode

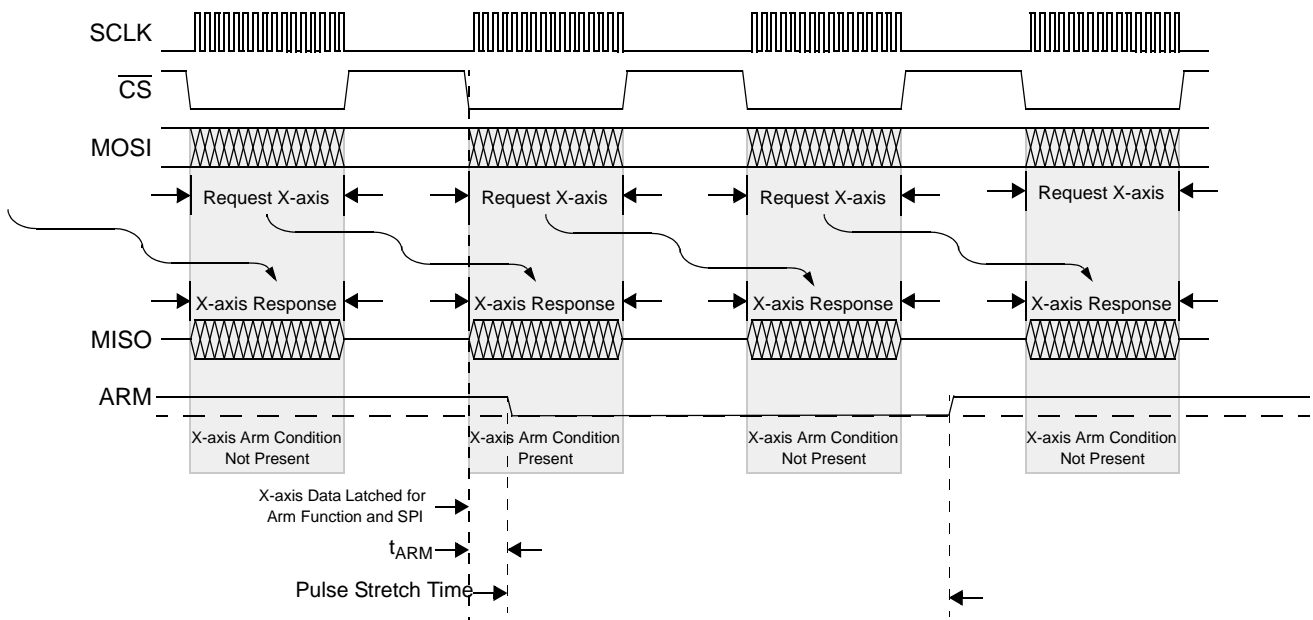

Figure 27. MMA685x Arming Condition, Moving Average and Count Mode

### 3.8.9.3 Arming Function: Unfiltered Mode

On the falling edge of  $\overline{CS}$  for an acceleration response, the most recent available DSP sample is compared against positive and negative thresholds that are programmed via the ARMT\_x registers. Reference [Section 3.1.9](#) for register details. If the sample equals or exceeds either threshold, an arming condition is indicated.

Once an arming condition is indicated for the ARM output is asserted when  $\overline{CS}$  is asserted and the MISO data includes an acceleration response.

The pulse stretch function is not applied in Unfiltered mode.

[Figure 28](#) contains a block diagram of the Arming Function operation in Unfiltered Mode. [Figure 29](#) shows the Arming output operation under the different SPI request conditions.

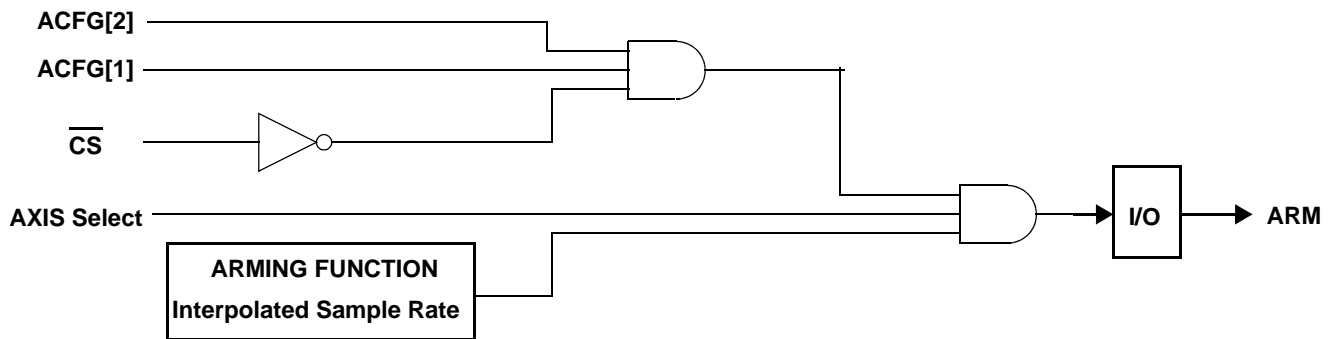

Figure 28. Arming Function Block Diagram - Unfiltered Mode

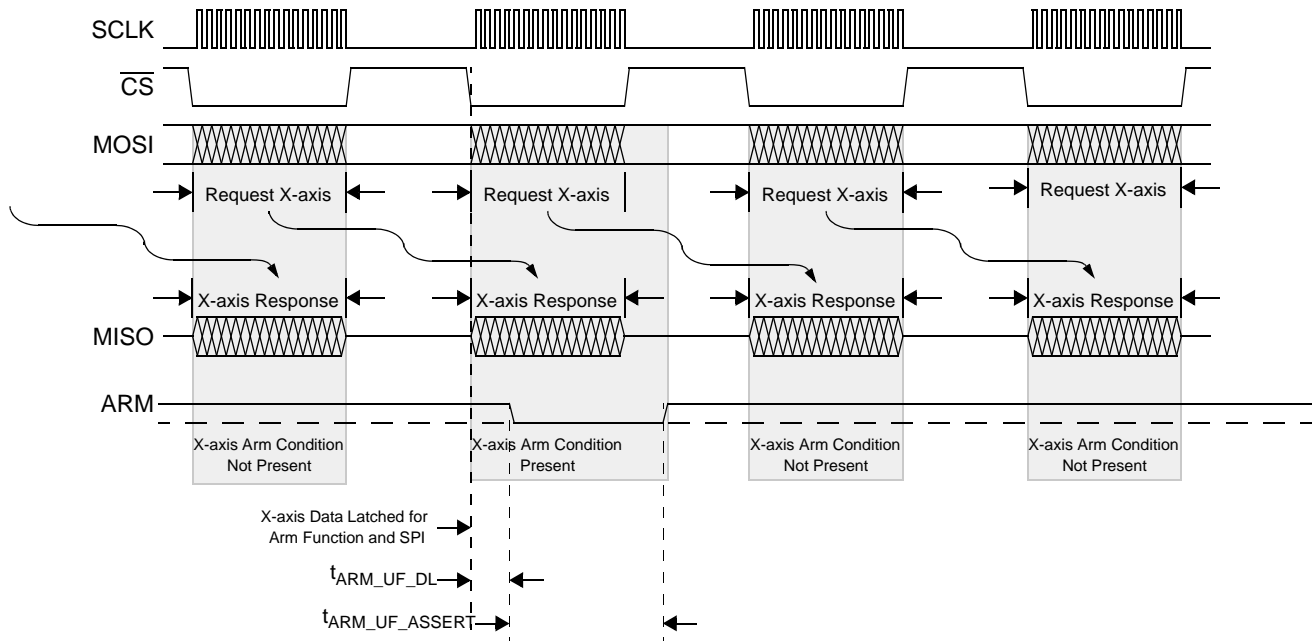

Figure 29. MMA685x Arming Conditions, Unfiltered Mode

### 3.8.9.4 Arming Pulse Stretch Function

A pulse stretch function can be applied to the arming output in moving average mode, or count mode.

If the pulse stretch function is not used ( $APS[1:0] = '00'$ ), the arming output is asserted if and only if an arming condition exists after the most recent evaluated sample. The arming output is de-asserted if and only if an arming condition does not exist after the most recent evaluated sample.

If the pulse stretch function is used, ( $APS[1:0]$  not equal  $'00'$ ), the arming output is controlled only by the value of the pulse stretch timer value. If the pulse stretch timer value is non-zero, the arming output is asserted. If the pulse stretch timer is zero, the arming output is de-asserted. The pulse stretch counter continuously decrements until it reaches zero. The pulse stretch counter is reset to the programmed pulse stretch value if and only if an arming condition exists after the most recent evaluated sample. Reference [Figure 27](#).

The desired pulse stretch time is programmable for via the  $APS[1:0]$  bits in the  $ARMCFG$  register.

Exception conditions listed in [Section 4.5](#) do not impact prior arming function responses. If an exception occurs after an arming activation, the corresponding pulse stretch for the existing arming condition will continue. However, new acceleration reads will not reset the pulse stretch counter regardless of the acceleration value.

### 3.8.9.5 Arming Pin Output Structure

The arming output pin structure can be set to active high, or active low with the  $A\_CFG$  bits in the  $DEVCFG$  register as described in [Section 3.1.6.5](#). The active high and active low pin output structures are shown in [Figure 30](#).

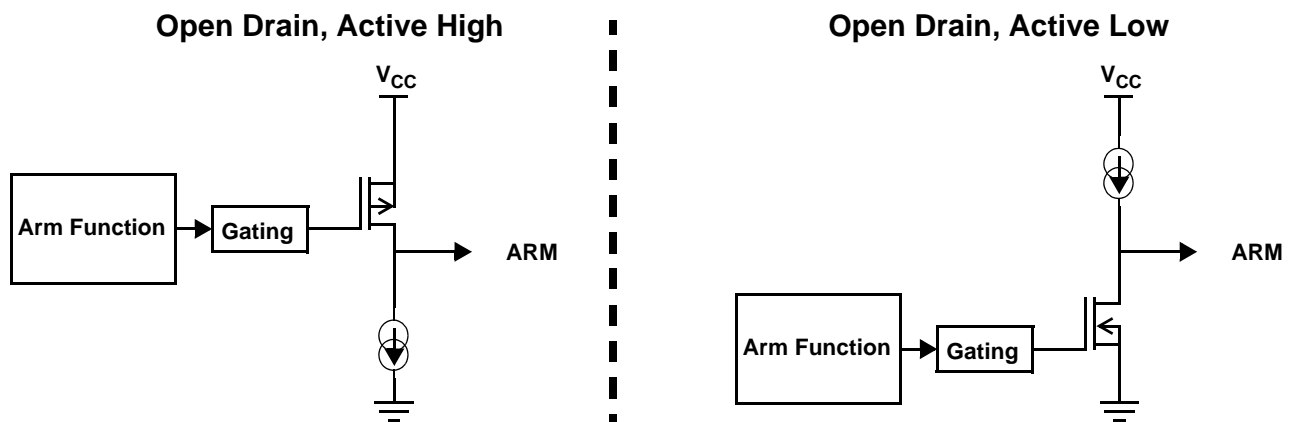

Figure 30. Arming Function - Pin Output Structure

### 3.8.10 PCM Output Function

MMA685x provides the option for a PCM output function. The PCM output is enabled by setting the  $A\_CFG$  bits in the  $DEVCFG$  register to the appropriate state as described in [Section 3.1.6.5](#). When the PCM function is enabled, the upper 9 bits of the 10-bit, offset cancelled, output scaled acceleration values are used to generate 8 MHz Pulse Code Modulated signals proportional to the acceleration onto the PCM pin. A block diagram of the PCM output is shown in [Figure 31](#).

Exception conditions affect the PCM output as listed in [Section 4.5](#).

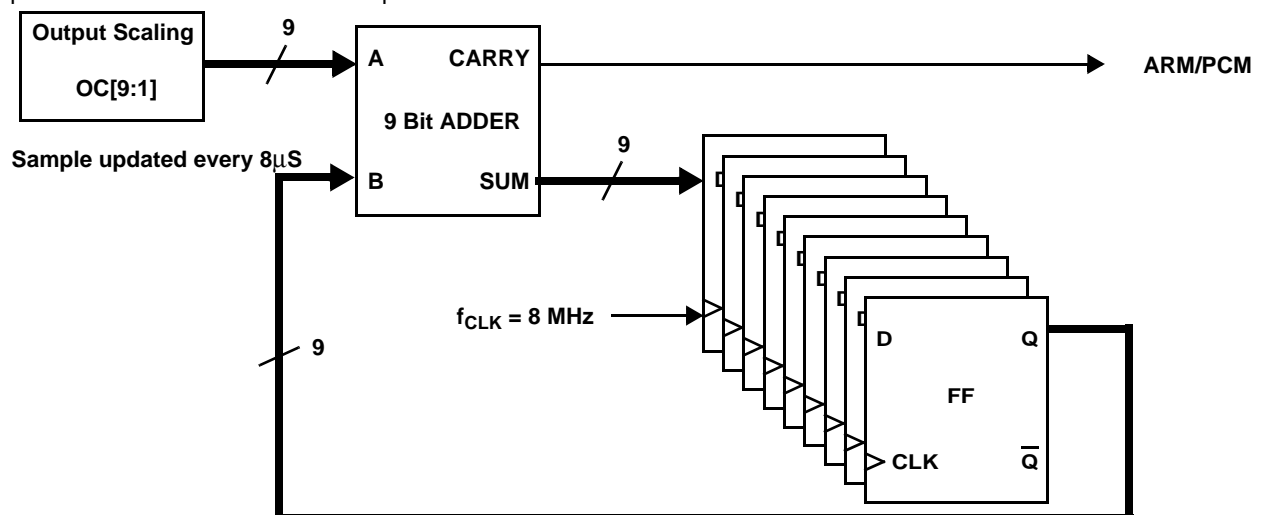

Figure 31. PCM Output Function Block Diagram

### 3.9 Serial Peripheral Interface

MMA685x includes a Serial Peripheral Interface (SPI) to provide access to the configuration registers and digital data. Reference [Section 4](#) for details regarding the SPI protocol and available commands.

### 3.10 Device Initialization

Following power-up, under-voltage reset, or a SPI reset command sequence, MMA685x proceeds through an internal initialization process as shown in [Figure 32](#). [Figure 32](#) also shows the MMA685x performance for an example external system level initialization procedure.

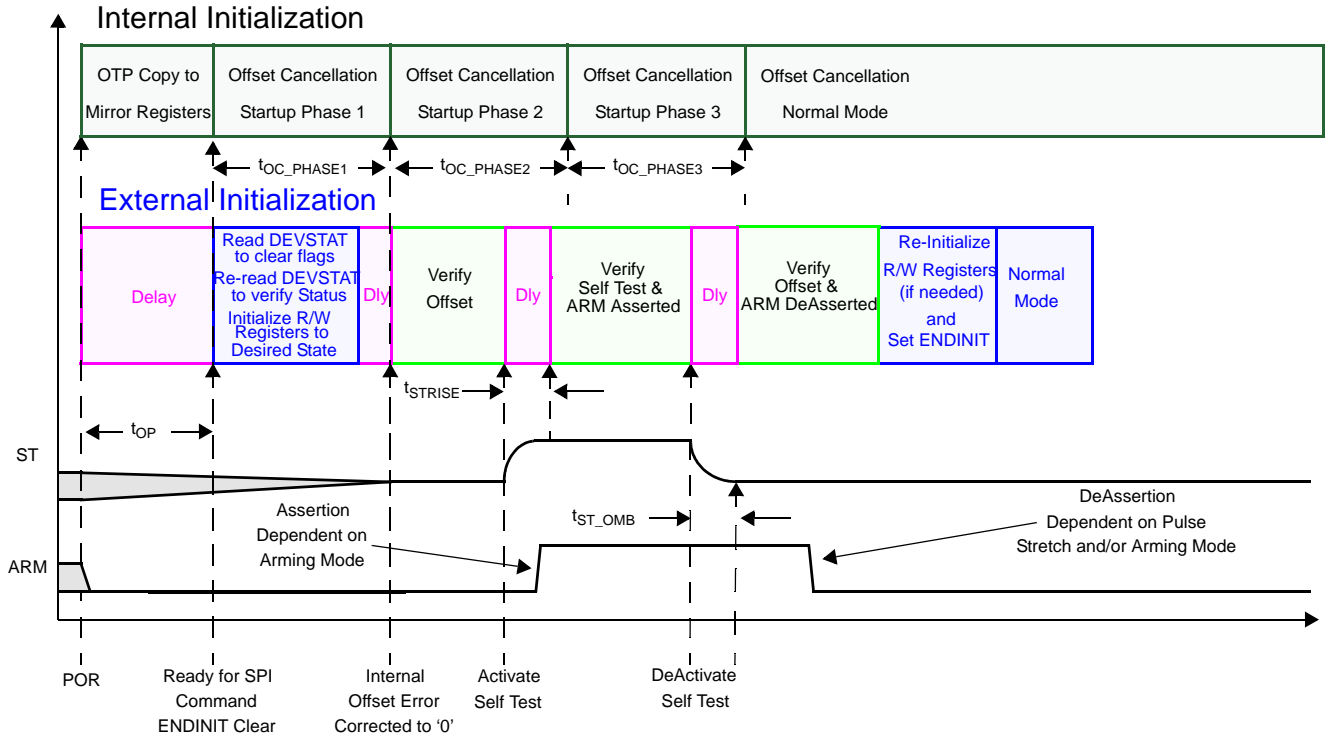

- Notes: 1) Self Test can be enabled and evaluated simultaneously to reduce test time.  
 For failure mode coverage of the arming pins and of potential common axis failures, NXP recommends independent self test activation.  
 2)  $t_{STRISE}$  and  $t_{STFALL}$  are dependent on the selected LPF group delay.

Figure 32. Initialization Process



## 3.11 Overload Response

### 3.11.1 Overload Performance

MMA685x is designed to operate within a specified range. Acceleration beyond that range (overload) impacts the output of the sensor. Acceleration beyond the range of the device can generate a DC shift at the output of the device that is dependent upon the overload frequency and amplitude. The MMA685x  $g$ -cell is overdamped, providing the optimal design for overload performance. However, the performance of the device during an overload condition is affected by many other parameters, including:

- $g$ -cell damping
- Non-linearity
- Clipping limits
- Symmetry

Figure 33 shows the  $g$ -cell, ADC and output clipping of MMA685x over frequency. The relevant parameters are specified in Section 2.1, and Section 2.6.

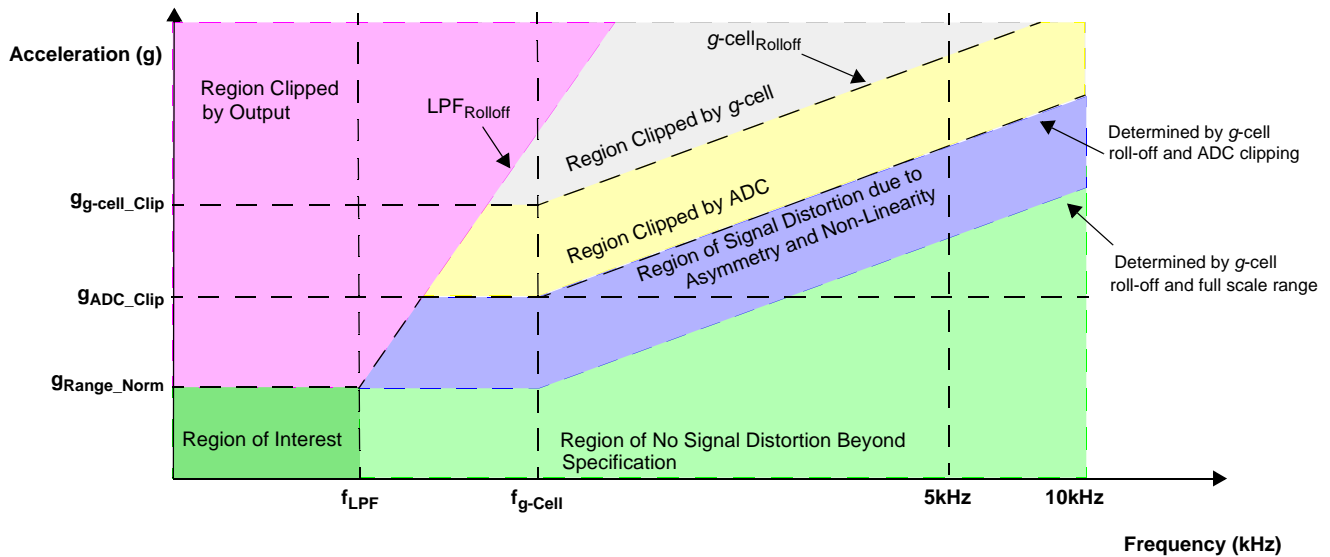

Figure 33. Output Clipping vs. Frequency

### 3.11.2 Sigma Delta Over Range Response

Over range conditions exist when the signal level is beyond the full-scale range of the device but within the computational limits of the DSP. The  $\Sigma\Delta$  converter can saturate at levels above those specified in Section 2.1 ( $G_{\text{ADC\_CLIP}}$ ). The DSP operates predictably under all cases of over range, although the signal may include residual high frequency components for some time after returning to the normal range of operation due to non-linear effects of the sensor.

## 4 SPI Communications

Communication with MMA685x is completed through synchronous serial transfers via SPI. MMA685x is a slave device configured for CPOL = 0, CPHA = 0, MSB first. SPI transfers are completed through a sequence of two phases. During the first phase, the type of transfer and associated control information is transmitted from the SPI master to MMA685x. Data from MMA685x is transmitted during the second phase. Any activity on MOSI or SCLK is ignored when CS is negated. Consequently, intermediate transfers involving other SPI devices may occur between phase one and phase two. Refer to [Figure 34](#).

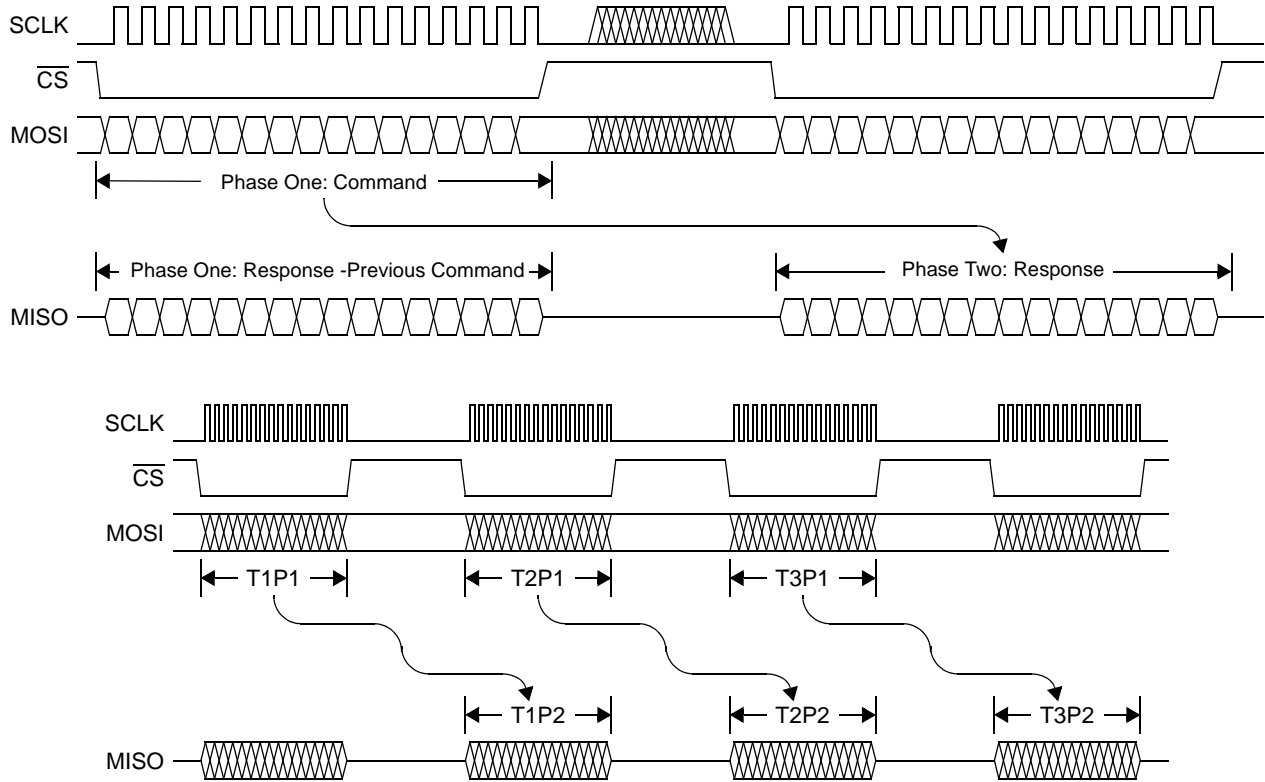

Figure 34. SPI Transfer Detail

## 4.1 SPI Command Format

Commands are transferred from the SPI master to MMA685x. Valid commands fall into two categories: register operations, and acceleration data requests.

**Table 26. SPI Command Message Summary**

MSB													LSB			Command Type	Reference	
15	14	13	12	11	10	9	8	7	6	5	4	3	2	1	0			
0	AX	A	OC	0	0	0	0	0	0	0	0	0	$\overline{SD}$	ARM	P			
AX= Axis Selection																		
0				Acceleration Data														
1				N/A														
A = Acceleration Data Request																		
0				Register Operation														
1				Acceleration Data Request														
$\overline{OC}$ = Offset Cancelled Data Request																		
0				Offset Cancelled Data Request														
1				Raw Acceleration Data Request														
$\overline{SD}$ = Signed Data Confirmation																		
				Signed Data Enabled										0				
				Unsigned Data Enabled										1				
ARM = ARM Function Status Confirmation																		
				Disabled / PCM Output Enabled										0				
				Arming Function Enabled										1				
													P = Odd Parity					
0	AX	A	OC	0	0	0	0	0	0	0	0	0	0	SD	ARM	P	Accel Data	
0	0	1	0	0	0	0	0	0	0	0	0	0	0	0	0	0	OC, Signed Data, Disabled/PCM	
0	0	1	0	0	0	0	0	0	0	0	0	0	0	0	1	1	OC, Signed Data, ARM Enabled	
0	0	1	0	0	0	0	0	0	0	0	0	0	0	1	0	1	OC, Unsigned Data, Disabled/PCM	
0	0	1	0	0	0	0	0	0	0	0	0	0	0	1	1	0	OC, Unsigned Data, ARM Enabled	
0	0	1	1	0	0	0	0	0	0	0	0	0	0	0	0	1	Raw, Signed Data, Disabled/PCM	
0	0	1	1	0	0	0	0	0	0	0	0	0	0	0	1	0	Raw, Signed Data, ARM Enabled	
0	0	1	1	0	0	0	0	0	0	0	0	0	0	1	0	0	Raw, Unsigned Data, Disabled/PCM	
0	0	1	1	0	0	0	0	0	0	0	0	0	0	1	1	1	Raw, Unsigned Data, ARM Enabled	
0	1	1	0	0	0	0	0	0	0	0	0	0	0	0	0	1	Invalid Command	
0	1	1	0	0	0	0	0	0	0	0	0	0	0	0	1	0	Invalid Command	
0	1	1	0	0	0	0	0	0	0	0	0	0	0	1	0	0	Invalid Command	
0	1	1	0	0	0	0	0	0	0	0	0	0	0	1	1	1	Invalid Command	
0	1	1	1	0	0	0	0	0	0	0	0	0	0	0	0	0	Invalid Command	
0	1	1	1	0	0	0	0	0	0	0	0	0	0	0	1	1	Invalid Command	
0	1	1	1	0	0	0	0	0	0	0	0	0	0	1	0	1	Invalid Command	
0	1	1	1	0	0	0	0	0	0	0	0	0	0	1	1	0	Invalid Command	
P	AX	A	D12	D11	D10	D9	D8	D7	D6	D5	D4	D3	D2	D1	D0	Command Type	Reference	
P	0	0	A4	A3	A2	A1	A0	0	0	0	0	0	0	0	0	Register Read	<a href="#">Section 4.4</a>	
			Register Address					Data to be Written to Register									Register Write	<a href="#">Section 4.4</a>
P = Odd Parity																		

## 4.2 SPI Response Format

Table 27. SPI Response Message Summary

			MSB													LSB						
			15	14	13	12	11	10	9	8	7	6	5	4	3	2	1	0				
CMD	A	AX	Response to Valid Acceleration Request															Data Type	Reference			
			OC	0	AX	P	S1	S0	D9	D8	D7	D6	D5	D4	D3	D2	D1			D0		
			OC = Offset Cancelled Data Requested																			
			0 Transferred Accel Data is Offset Cancelled Data																			
			1 Transferred Accel Data is Raw Data																			
			AX = Axis Requested																			
			0 Acceleration Data Response																			
			1 N/A																			
			P = Odd Parity																			
			S[1:0] = Device Status																			
0 0 In Initialization (ENDINIT = '0')																						
0 1 Normal Data Request																						
1 0 ST Active, ΣΔ/Offset Over range Present																						
1 1 Internal Error Present / SPI Error																						
Valid Accel Data Request	A	AX	OC	0	0	P	0	1	Acceleration Data										Accel	Section 4.3		
			OC	0	0	P	1	0	Self-test Active Acceleration Data										Accel			
			OC	0	0	P	0	0	Acceleration Data, Initialization in Process (ENDINIT='0')										Accel			
			OC	0	1	P	0	1	Invalid Accel Request										N/A			
			OC	0	1	P	1	0	Invalid Accel Request										N/A			
			OC	0	1	P	1	0	Invalid Accel Request										N/A			
			OC	0	1	P	0	0	Invalid Accel Request										N/A			
			MSB													LSB						
			15	14	13	12	11	10	9	8	7	6	5	4	3	2	1	0				
CMD	A	AX	Response to Valid Register Access															Data Type	Reference			
			D15	D14	AX	P	D11	D10	D9	D8	D7	D6	D5	D4	D3	D2	D1			D0		
Register Write	0	1	0	0	1	P	1	1	1	0	D7	D6	D5	D4	D3	D2	D1	D0	Register Write	Section 4.4.1		
New Contents of Register																						
Register Read	0	0	0	1	0	P	1	1	1	0	D7	D6	D5	D4	D3	D2	D1	D0	Register Read	Section 4.4.2		
Contents of Register																						
			MSB													LSB						
			15	14	13	12	11	10	9	8	7	6	5	4	3	2	1	0				
CMD	A	AX	Error Responses															Data Type	Reference			
			D15	D14	AX	P	D11	D10	D9	D8	D7	D6	D5	D4	D3	D2	D1			D0		
Invalid Accel Request	x	x																	Register Setting Mismatch	Section 4.3		
Internal Error Present	x	x																	IDE Bit Set (Excl. Self-test), DEVINIT Bit Set, DEVRES Bit Set	Section 4.5.5		
MISO Error	x	x	0	0	0	P	1	1	SD = 1: 00 0000 0000 SD = 0: 10 0000 0000										MISO Error on Previous Msg	Section 4.5.2		
SPI Error	x	x																	MOSI Parity, CMD Bit 15 = 1, SPI Timing Err, SPI Mismatch Err, SPI Protocol Errs	Section 4.5.1		
Invalid Register Request	0	x	0	0	0	0	1	1	1	0	0	0	0	0	0	0	0	0	Invalid Reg Addr, Write while ENDINIT set, Write to R/O Reg	Section 4.4		
Self-test Error	0	x	0	0	1	P	1	1	SD = 1: 00 0000 0000 SD = 0: 10 0000 0000										IDE Bit set due to Self-test Error	Section 4.5.5		

### 4.3 Acceleration Data Transfers

Acceleration data requests are initiated when the Acceleration bit of the SPI command message (A) is set to a logic '1'. The Axis Selection bit (AX) and the Offset Cancellation Selection bit ( $\overline{OC}$ ) of the command message select the type of acceleration data requested, as shown in [Table 28](#).

**Table 28. Acceleration Data Request**

Acceleration Data Request Command Information		Data Type
Axis Selection Bit (AX)	Offset Cancellation Select ( $\overline{OC}$ )	
0	0	Offset Cancelled Data
0	1	Raw Data
1	0	Invalid Accel Request
1	1	Invalid Accel Request

To verify that MMA685x is configured as expected, each acceleration data request includes the configuration information that impacts the output data. The requested configuration is compared against the data programmed in the writable register array. Details are shown in [Table 29](#).

**Table 29. Acceleration Data Request Configuration Information**

Programmable Option	Command Message Bit	Writable Register Information
Signed or Unsigned Data	$\overline{SD}$	DEVCFG[4] ( $\overline{SD}$ )
Arming Function or PCM Output	ARM	DEVCFG[2]    DEVCFG[1] (A_CFG[2]    A_CFG[1])

If the data listed in [Table 29](#) does not match, an Acceleration Data Request Mismatch failure is detected and no acceleration data is transmitted. Reference [Section 4.5.3.1](#).

Acceleration data request commands include a parity bit (P). Odd parity is employed. The number of logic '1' bits in the acceleration data request command must be an odd number.

Acceleration data is transmitted on the next SPI message if and only if all of the following conditions are met:

- The DEVINIT bit in the DEVSTAT register is not set
- The DEVRES bit in the DEVSTAT register is not set
- The IDE bit in the DEVSTAT register is not set (Reference [Section 4.5.5](#))
- No SPI Error is detected (Reference [Section 4.5.1](#))
- No MISO Error is detected (Reference [Section 4.5.2](#))
- No Acceleration Data Request Mismatch failure is detected (Reference [Section 4.5.3.1](#))
- No Self-test Error is present (reference [Section 4.5.5.2](#))

If the above conditions are met, MMA685x responds with a "valid acceleration data request" response as shown in [Table 27](#). Otherwise, MMA685x responds as specified in [Section 4.5](#).

### 4.4 Register Access Operations

Two types of register access operations are supported; register write, and register read. Register access operations are initiated when the acceleration bit (A) of the command message is set to a logic '0'. The operation to be performed is indicated by the Access Selection bit (AX) of the command message.

Access Selection Bit (AX)	Operation
0	Register Read
1	Register Write

Register Access operations include a parity bit (P). Odd parity is employed. The number of logic '1' bits in the Register Access operation must be an odd number.

### 4.4.1 Register Write Request

During a register write request, bits 12 through 8 contain a 5-bit address, and bits 7 through 0 contain the data value to be written. Writable registers are defined in [Table 3](#).

The response to a register write operation is shown in [Table 27](#). The response is transmitted on the next SPI message if and only if all of the following conditions are met:

- No SPI Error is detected (Reference [Section 4.5.1](#))
- No MISO Error is detected (Reference [Section 4.5.2](#))
- The ENDINIT bit is cleared (Reference [Section 3.1.6.2](#))
  - This applies to all registers with the exception of the DEVCTL register
- No Invalid Register Request is detected (Reference [Section 4.5.3.2](#))

If the above conditions are met, MMA685x responds to the register write request as shown in [Table 27](#). Otherwise, MMA685x responds as specified in [Section 4.5](#).

Register write operations do not occur internally until the transfer during which they are requested has been completed. In the event that a SPI Error is detected during a register write transfer, the write operation is not completed.

### 4.4.2 Register Read Request

During a register read request, bits 12 through 8 contain the 5-bit address for the register to be read. Bits 7 through 0 must be logic '0'. Readable registers are defined in [Table 3](#).

The response to a register read operation is shown in [Table 27](#). The response is transmitted on the next SPI message if and only if all of the following conditions are met:

- No SPI Error is detected (Reference [Section 4.5.1](#))
- No MISO Error is detected (Reference [Section 4.5.2](#))
- No Invalid Register Request is detected (Reference [Section 4.5.3.2](#))

If the above conditions are met, MMA685x responds to the register read request as shown in [Table 27](#). Otherwise, MMA685x responds as specified in [Section 4.5](#).

## 4.5 Exception Handling

The following sections describe the conditions for each detectable exception, and the MMA685x response for each exception. In the event that multiple exceptions exist, the exception response is determined by the priority listed in [Table 30](#).

**Table 30. SPI Error Response Priority**

Error Priority	Exception	Effect on Data		
		SPI Data	Arming Output	PCM Output
1	SPI Error	Error Response	No Update	No Effect
2	SPI MISO Error	Error Response	No Update	No Effect
3	Invalid Request	Error Response	No Update	No Effect
4	DEVINIT Bit Set	Error Response	No Update	Disabled
5	DEVRES Error	Error Response	No Update	Disabled
6	CRC Error	Error Response	No Update	No Effect
7	Self-test Error	Error Response	No Update	No Effect
8	Offset Monitor Over Range	No Effect	No Effect	No Effect
9	$\Sigma\Delta$ Over Range	No Effect	No Effect	No Effect

## 4.5.1 SPI Error

The following SPI conditions result in a SPI error:

- SCLK is high when  $\overline{CS}$  is asserted
- the number of SCLK rising edges detected while  $\overline{CS}$  is asserted is not equal to 16
- SCLK is high when  $\overline{CS}$  is negated
- Command message parity error (MOSI)
- Bit 15 of Acceleration Data Request is not equal to '0'
- Bits 3 through 11 of an Acceleration Request are not equal to '0'
- Bits 0 through 7 of a Register Read Request are not equal to '0'

MMA685x responds to a SPI error with a “SPI Error” response as shown in [Table 27](#). This applies to both acceleration data request SPI errors, and Register Access SPI errors.

The arming function will not be updated if a SPI Error is detected. The PCM output is not affected by a SPI Error.

## 4.5.2 SPI Data Output Verification Error

MMA685x includes a function to verify the integrity of the data output to the MISO pin. The function reads the data transmitted on the MISO pin and compares it against the data intended to be transmitted. If any one bit doesn't match, a SPI MISO Mismatch Fault is detected and the MISOERR flag in the DEVSTAT register is set.

If a valid SPI acceleration request message is received during the SPI transfer with the MISO mismatch failure, the SPI acceleration request message is ignored and MMA685x responds with a “MISO Error” response during the subsequent SPI message (reference [Table 27](#)). The Arming function is not updated if a MISO mismatch failure occurs. The PCM function is not affected by the MISO mismatch failure.

If a valid SPI register write request message is received during the SPI transfer with the MISO mismatch failure, the register write is completed as requested, but MMA685x responds with a “MISO Error” response as shown in [Table 27](#), during the subsequent SPI message.

If a valid SPI register read request message is received during the SPI transfer with the MISO mismatch failure, the register read is ignored and MMA685x responds with a “MISO Error” response as shown in [Table 27](#), during the subsequent SPI message. If the register read request is for the DEVSTAT register, the DEVSTAT register will not be cleared.

In all cases, the MISOERR flag in the DEVSTAT register will remain set until a successful SPI Register Read Request of the DEVSTAT register is completed.

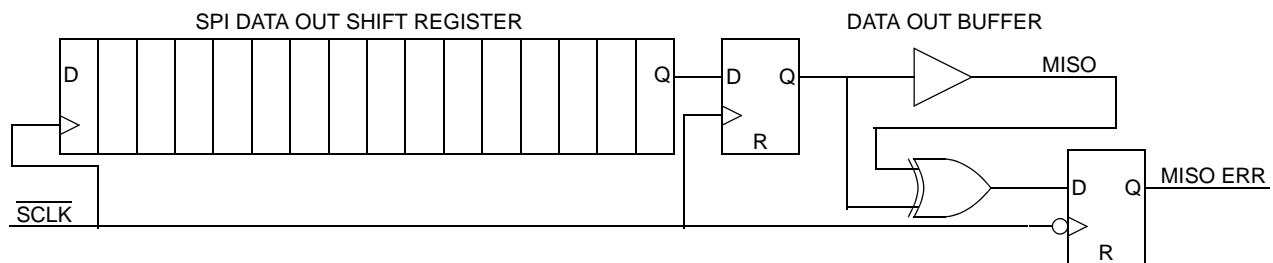

Figure 35. SPI Data Output Verification

## 4.5.3 Invalid Requests

### 4.5.3.1 Invalid Acceleration Request

The following conditions result in an “Invalid Acceleration Request” error:

- The Axis Selection bit (AX) in the Command message is set
- The SPI “Acceleration Data Request” Command data listed in [Section 4.3, Table 29](#) does not match the internal register settings

MMA685x responds to an “Invalid Acceleration Request” error with an “Invalid Accel Request” response as specified in [Table 27](#) on the subsequent SPI message only. No internal fault is recorded. The arming function will not be updated if an “Acceleration Data Request Mismatch” Error is detected. The PCM output is not affected by the “Acceleration Data Request Mismatch” error.

Register operations will be executed as specified in [Section 4.4](#).

### 4.5.3.2 Invalid Register Request

The following conditions result in an “Invalid Register Request” error:

- An attempt is made to write to an un-writable register (Writable registers are defined in [Section 3.1, Table 3](#)). Attempts to write to registers \$0D, \$0F, \$11, and \$13 will also result in an error.
- An attempt is made to write to a register while the ENDINIT bit in the DEVCFG register is set
  - This applies to all registers with the exception of the DEVCTL register
- An attempt is made to read an un-readable register (Readable registers are defined in [Section 3.1, Table 3](#)). Attempts to read registers \$07, \$0D, \$0F, \$11, and \$13 will also result in an error.

MMA685x responds to an Invalid Register Request” error with an “Invalid Register Request” response as shown in [Table 27](#).

#### 4.5.4 Device Reset Indications

If the DEVINIT, or DEVRES bit is set in the DEVSTAT register as described in [Section 3.1.10](#), MMA685x will respond to acceleration data requests with an “Internal Error Present” response until the bits are cleared in the DEVSTAT register. The DEVINIT bit is cleared automatically when device initialization is complete (Reference  $t_{OP}$  in [Section 2.6](#)). The DEVRES bit is cleared on a read of the DEVSTAT register. The arming function will not be updated on Acceleration Data Request commands if the DEVINIT or DEVRES bit is set in the DEVSTAT register. The PCM output is disabled if the DEVINIT or DEVRES bit is set.

#### 4.5.5 Internal Error

The following errors will result in an internal error, and set the IDE bit in the DEVSTAT register:

- OTP CRC Failure
- Writable Register CRC Failure
- Self-test Error
- Invalid internal logic states

##### 4.5.5.1 CRC Error

If the IDE bit is set in the DEVSTAT register due to an OTP Shadow Register or Writable Register CRC failure as described in [Section 3.2](#), MMA685x will respond to acceleration data requests with an “Internal Error Present” response until the IDE bit is cleared in the DEVSTAT register. The arming function will not be updated on Acceleration Data Request commands if a CRC Error is detected. The PCM output is not affected by the CRC error.

If the CRC error is in the writable register array, and the ENDINIT bit in the DEVCFG register has been set, the error can only be cleared by a device reset. The IDE bit will not be cleared on a read of the DEVSTAT register.

If the CRC error is in the OTP shadow register array, the error cannot be cleared.

Register operations will be executed as specified in [Section 4.4](#).

##### 4.5.5.2 Self-test Error

If the IDE bit is set in the DEVSTAT register due to a Self-test activation failure, MMA685x will respond to acceleration data requests with a “Self-test Error” response until the IDE bit is cleared in the DEVSTAT register. The arming function will not be updated on Acceleration Data Request commands if a Self-test Error is detected. The PCM output is not affected by the Self-test Error. The IDE bit in the DEVSTAT register will remain set until a read of the DEVSTAT register occurs, even if the internal failure is removed. If the internal error is still present when the DEVSTAT register is read, the IDE bit will remain set.

Register operations will be executed as specified in [Section 4.4](#).

#### 4.5.6 Offset Monitor Over Range

If an offset monitor over range is present as described in [Section 3.8.5](#), MMA685x will respond to an acceleration request with a “Valid Acceleration Data Request” response, but the Status bits (S[1:0]) will be set to ‘10’. The arming function will be updated on Acceleration Data Request commands even if an Offset Monitor Over Range is detected. Once the over range condition is removed, MMA685x will respond to acceleration requests with a “Valid Acceleration Data Request” response with the Status bits (S[1:0]) set to ‘10’ on the next SPI transfer, and a “Valid Acceleration Data Request” response with normal status on subsequent SPI transfers. The OFF bit in the DEVSTAT register will remain set until a read of the DEVSTAT register occurs.

The PCM output is not affected by the offset monitor over range condition.

Register operations will be executed as specified in [Section 4.4](#).



## 4.5.7 $\Sigma\Delta$ Over Range

If a  $\Sigma\Delta$  Over Range failure is present as described in [Section 3.11.2](#), MMA685x will respond to acceleration data requests with a “Valid Acceleration Data Request” response, but the Status bits (S[1:0]) will be set to ‘10’. The arming function will be updated on Acceleration Data Request commands even if a  $\Sigma\Delta$  Over Range is detected. Once the over range condition is removed, MMA685x will respond to acceleration requests with a “Valid Acceleration Data Request” response with the Status bits (S[1:0]) set to ‘10’ on the next SPI transfer, and a “Valid Acceleration Data Request” response with normal status on subsequent SPI transfers. The SDOV bit in the DEVSTAT register will remain set until a read of the DEVSTAT register occurs.

The PCM output is not affected by the  $\Sigma\Delta$  over range condition.

Register operations will be executed as specified in [Section 4.4](#).

## 4.6 Initialization SPI Response

The first data transmitted by MMA685x following reset is the SPI Error response shown in [Table 27](#). This ensures that an unexpected reset will always be detectable. MMA685x will respond to all acceleration data requests with the “Invalid Acceleration Data Request” response until the DEVRES bit in the DEVSTAT register is cleared via a read of the DEVSTAT register. The arming function will not be updated on Acceleration Data Request commands until the DEVRES bit in the DEVSTAT register is cleared.

## 4.7 Acceleration Data Representation

Acceleration values are determined from the 10-bit digital output (DV) using the following equations:

$$\text{Acceleration} = \text{Sensitivity}_{\text{LSB}} \times \text{DV} \quad \text{For Signed Data}$$

$$\text{Acceleration} = \text{Sensitivity}_{\text{LSB}} \times (\text{DV} - 512) \quad \text{For Unsigned Data}$$

The linear range of digital values for signed data is  $-480$  to  $+480$ , and for unsigned data is 32 to 992. Resulting ranges and some nominal acceleration values are shown in [Table 31](#).

**Table 31. Nominal Acceleration Data Values**

Unsigned Digital Value	Signed Digital Value	Nominal Acceleration	
		Trimmed for Maximum Sensitivity (g)	Trimmed for Maximum Range (g)
993 to 1023	481 to 511	Unused	
992	480	19.666	117.19
991	479	19.625	116.94
•	•	•	•
•	•	•	•
•	•	•	•
514	2	+0.082	+0.488
513	1	+0.041	+0.244
512	0	0	0
511	-1	-0.041	-0.244
510	-2	-0.082	-0.488
•	•	•	•
•	•	•	•
•	•	•	•
33	-479	-19.625	-116.94
32	-480	-19.666	-117.19
1 to 31	-481 to -511	Unused	
0	-512	Fault	

[Figure 36](#) shows the how the possible output data codes are determined from the input data and the error sources. The relevant parameters are specified in [Section 2.4](#).

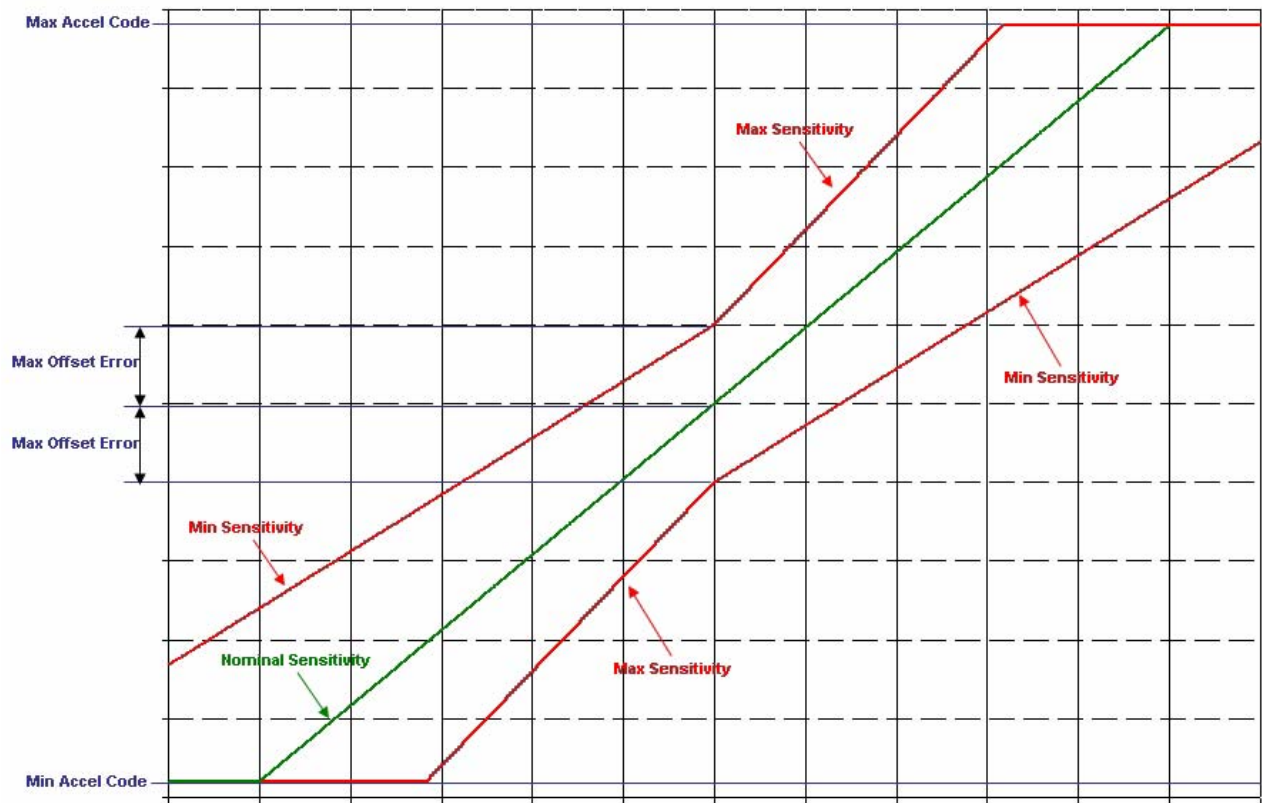

Figure 36. MMA685x Acceleration Data Output vs. Acceleration Input

## 5 Package

### 5.1 Case Outline Drawing

Reference NXP case outline document 98ASA00690D.

<http://cache.nxp.com/assets/documents/data/en/package-information/98ASA00690D.pdf>

### 5.2 Recommended Footprint

Reference NXP application note AN1902, latest revision:

<http://www.nxp.com/assets/documents/data/en/application-notes/AN1902.pdf>

## 6 Revision History

Table 32. Revision History

Revision number	Revision date	Description of changes
9.0	01/2017	<ul style="list-style-type: none"><li>Deleted part numbers MMA6851BKTCW, MMA6853BKTCW, MMA6855BKTCW, and MMA6856BKTCW.</li><li>Updated part marking diagram to reflect deletions.</li></ul>
8.0	4/2016	
7	01/2016	
6	11/2014	
5	03/2012	
4	12/2011	



**How to Reach Us:**

**Home Page:**

[NXP.com](http://www.nxp.com)

**Web Support:**

<http://www.nxp.com/support>

Information in this document is provided solely to enable system and software implementers to use NXP products.

There are no expressed or implied copyright licenses granted hereunder to design or fabricate any integrated circuits based on the information in this document. NXP reserves the right to make changes without further notice to any products herein.

NXP makes no warranty, representation, or guarantee regarding the suitability of its products for any particular purpose, nor does NXP assume any liability arising out of the application or use of any product or circuit, and specifically disclaims any and all liability, including without limitation, consequential or incidental damages. "Typical" parameters that may be provided in NXP data sheets and/or specifications can and do vary in different applications, and actual performance may vary over time. All operating parameters, including "typicals," must be validated for each customer application by the customer's technical experts. NXP does not convey any license under its patent rights nor the rights of others. NXP sells products pursuant to standard terms and conditions of sale, which can be found at the following address:

<http://www.nxp.com/terms-of-use.html>.

NXP, the NXP logo, Freescale, the Freescale logo, SafeAssure, and the SafeAssure logo, are trademarks of NXP B.V. All other product or service names are the property of their respective owners. All rights reserved.

© 2017 NXP B.V.

Document Number: MMA685x  
Rev. 8.0  
01/2017



Компания «Life Electronics» занимается поставками электронных компонентов импортного и отечественного производства от производителей и со складов крупных дистрибьюторов Европы, Америки и Азии.

С конца 2013 года компания активно расширяет линейку поставок компонентов по направлению коаксиальный кабель, кварцевые генераторы и конденсаторы (керамические, пленочные, электролитические), за счёт заключения дистрибьюторских договоров

Мы предлагаем:

- Конкурентоспособные цены и скидки постоянным клиентам.
- Специальные условия для постоянных клиентов.
- Подбор аналогов.
- Поставку компонентов в любых объемах, удовлетворяющих вашим потребностям.
- Приемлемые сроки поставки, возможна ускоренная поставка.
- Доставку товара в любую точку России и стран СНГ.
- Комплексную поставку.
- Работу по проектам и поставку образцов.
- Формирование склада под заказчика.
- Сертификаты соответствия на поставляемую продукцию (по желанию клиента).
- Тестирование поставляемой продукции.
- Поставку компонентов, требующих военную и космическую приемку.
- Входной контроль качества.
- Наличие сертификата ISO.

В составе нашей компании организован Конструкторский отдел, призванный помогать разработчикам, и инженерам.

Конструкторский отдел помогает осуществить:

- Регистрацию проекта у производителя компонентов.
- Техническую поддержку проекта.
- Защиту от снятия компонента с производства.
- Оценку стоимости проекта по компонентам.
- Изготовление тестовой платы монтаж и пусконаладочные работы.



Тел: +7 (812) 336 43 04 (многоканальный)

Email: [org@lifeelectronics.ru](mailto:org@lifeelectronics.ru)