

#### FEATURES

- Good CMRR: typ. 50 dB at 60Hz
- Low cost, self-contained, dual
- Excellent audio performance
  - Wide bandwidth: typ. >7.6 MHz
  - High slew rate: typ. 14 V/ $\mu$ s
  - Low distortion: typ. 0.0006% THD
  - Low noise: typ. -104 dBu
- Low current: typ. 3 mA (per amplifier)
- Several gains: 0 dB,  $\pm 3$  dB,  $\pm 6$  dB

#### APPLICATIONS

- Balanced Audio Line Receivers
- Instrumentation Amplifiers
- Differential Amplifiers
- Precision Summers
- Current Shunt Monitors

#### Description

The THAT 1290 series of precision differential amplifiers was designed primarily for use as balanced line receivers for audio applications. Gains of 0 dB,  $\pm 3$  dB, and  $\pm 6$  dB are available to suit various applications requirements.

These devices include on-board precision thin-film resistors which offer good matching and excellent tracking due to their monolithic construction. Manufactured in THAT Corporation's proprietary complementary dielectric isolation (DI) process, the 1290 series provides the

sonic benefits of discrete designs with the simplicity, reliability, matching, and small size of a fully integrated solution.

All three versions of the part typically exhibit 50 dB of common-mode rejection. With 14 V/ $\mu$ s slew rate, 7.6 MHz or higher bandwidth, and 0.0006% THD, these devices are sonically transparent. Moreover, current consumption is typically a low 6 mA (3 mA per amplifier).

The 1290 series is available in a 16-pin QSOP package.

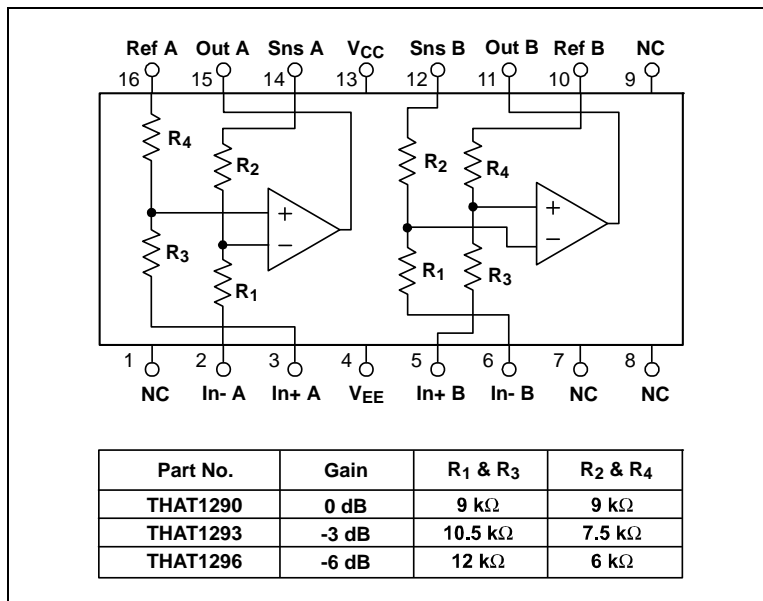

Figure 1. Equivalent circuit

Pin Name	Pin Number
N/C	1
IN- A	2
IN+ A	3
V <sub>EE</sub>	4
IN+ B	5
IN- B	6
N/C	7
N/C	8
N/C	9
REF B	10
OUT B	11
SENSE B	12
V <sub>CC</sub>	13
SENSE A	14
OUT A	15
REF A	16

Table 1. Pin assignments

**SPECIFICATIONS<sup>1</sup>****Absolute Maximum Ratings<sup>2,3</sup>**

Supply Voltages ( $V_{CC} - V_{EE}$ )	40V	Storage Temperature Range ( $T_{ST}$ )	-40 to +125 °C
Maximum In- or In+ Voltage	-50V + $V_{CC}$ , +50V + $V_{EE}$	Operating Temperature Range ( $T_{OP}$ )	-40 to +85 °C
Max/Min Ref or Sense Voltage	$V_{CC} + 0.5V$ , $V_{EE} - 0.5V$	Output Short-Circuit Duration ( $t_{SH}$ )	Continuous
Maximum Output Voltage ( $V_{OM}$ )	$V_{CC} + 0.5V$ , $V_{EE} - 0.5V$	Junction Temperature ( $T_J$ )	+125 °C

**Electrical Characteristics<sup>2,4</sup>**

Parameter	Symbol	Conditions	Min	Typ	Max	Units	
Supply Current	$I_{CC}; -I_{EE}$	No signal	—	6	8	mA	
Supply Voltage	$V_{CC}-V_{EE}$		6	—	36	V	
Input Voltage Range	$V_{IN-DIFF}$	Differential (equal and opposite swing)	1290 (0dB gain)	—	21.5	—	dBu
			1293 (-3dB gain)	—	24.5	—	dBu
			1296 (-6dB gain)	—	27.5	—	dBu
	$V_{IN-CM}$	Common Mode	1290 (0dB gain)	—	27.5	—	dBu
			1293 (-3dB gain)	—	29.1	—	dBu
			1296 (-6dB gain)	—	31	—	dBu
Input Impedance <sup>5</sup>	$Z_{IN-DIFF}$	Differential	1290 (0dB gain)	—	18	—	k $\Omega$
			1293 (-3dB gain)	—	21	—	k $\Omega$
			1296 (-6dB gain)	—	24	—	k $\Omega$
	$Z_{IN-CM}$	Common Mode	All versions	—	18	—	k $\Omega$
Common Mode Rejection Ratio	CMRR	Matched source impedances DC, $V_{CM} = \pm 10V$ 60Hz 20kHz	40	50	—	dB	
			40	50	—	dB	
			—	50	—	dB	
Power Supply Rejection Ratio <sup>6</sup>	PSRR	$\pm 3V$ to $\pm 18V$ ; $V_{CC} = -V_{EE}$ ; all gains	—	90	—	dB	
Total Harmonic Distortion	THD	$V_{out} = 5V_{rms}$ , $f = 1kHz$ , $BW = 22kHz$ , $R_L = 2k\Omega$	—	0.0006	—	%	
Output Noise	$e_{OUT}$	22 Hz to 22kHz bandwidth	1290 (0dB gain)	—	-104	—	dBu
			1293 (-3dB gain)	—	-105.5	—	dBu
			1296 (-6dB gain)	—	-107	—	dBu
Slew Rate	SR	$R_L = 2k\Omega$ ; $C_L = 200 pF$ , all gains	—	14	—	V/ $\mu s$	

1. All specifications are subject to change without notice.

2. Unless otherwise noted,  $T_A = 25^\circ C$ ,  $V_{CC} = +15V$ ,  $V_{EE} = -15V$ .

3. Stresses above those listed under "Absolute Maximum Ratings" may cause permanent damage to the device. These are stress ratings only; the functional operation of the device at these or any other conditions above those indicated in the operational sections of this specification is not implied. Exposure to absolute maximum rating conditions for extended periods may affect device reliability.

4. 0 dBu = 0.775 Vrms.

5. Absolute resistance values can vary  $\pm 30\%$  from the typical values shown. Input impedance is monitored by lot sampling.

6. Defined with respect to differential gain.

7. Parameter guaranteed over the entire range of power supply and temperature.

<b>Electrical Characteristics (con't)</b> <sup>2,4</sup>						
Parameter	Symbol	Conditions	Min	Typ	Max	Units
Small signal bandwidth	$BW_{-3dB}$	$R_L = 2k\Omega; C_L = 10\text{ pF}$ 1290 (0dB gain) 1293 (-3dB gain) 1296 (-6dB gain)	—	7.6	—	MHz
			—	9.6	—	MHz
			—	11.6	—	MHz
			—	—	—	—
Output Gain Error	$G_{ER-OUT}$		-0.2	0	0.2	dB
Output Voltage Swing	$V_{O+}$	$R_L = 2k\Omega; C_L = 200\text{ pF}$	$V_{CC-3}$	$V_{CC-2}$	—	V
	$V_{O-}$	$R_L = 2k\Omega; C_L = 200\text{ pF}$	—	$V_{EE+2}$	$V_{EE+3}$	V
Output Offset Voltage	$V_{OFF}$	No signal	-10	—	10	mV
Output Short Circuit Current	$I_{SC}$	$R_L = 0\ \Omega$	—	$\pm 42$	—	mA
Capacitive Load <sup>7</sup>	$C_L$		—	—	200	pF
Channel Separation		$f = 1\text{ kHz}$	—	120	—	dB



Figure 2. Simplified test circuit (1/2 of 129x shown)

## Theory of Operation

The THAT 1290 series ICs consist of two high performance opamps with integrated, thin-film resistors. These designs take advantage of THAT's fully complementary dielectric isolation (DI) process to deliver excellent performance with low current consumption. The devices are simple to apply in a wide range of applications.

### Resistor Matching, Values, and CMRR

The 1290-series devices rely upon the inherent matching of silicon-chromium (Si-Cr), thin-film, integrated resistors to achieve a 50 dB common mode rejection ratio and tight gain accuracy. No trimming is performed. As a result of their monolithic construction, the  $R_3/R_4$  ratio matches within  $\pm 0.5\%$  of the  $R_1/R_2$  ratio. 0.5% matching is about 50 dB CMRR for the 1296 and 52 dB for the 1290.

However, while the resistor ratios are tightly controlled, the actual value of any individual resistor is not. Lot-to-lot variations of up to  $\pm 30\%$  are to be expected.

If higher CMRR is required in a simple dual input stage, consider the THAT 1280-series ICs. These parts are laser-trimmed to improve the inherent precision of our thin-film resistor process. For demanding applications in which the source impedance balance may be less than perfect, the 1200-series ICs offer exceptional CMRR performance via a patented method of increasing common-mode input impedance.

### Input Considerations

The 1290-series devices are internally protected against input overload via an unusual arrangement of diodes connecting the + and - input pins to the power supply pins. The circuit of Figure 3 shows the arrangement used for the  $R_3/R_4$  side; a similar one applies to the other side. The zener diodes prevent the protection network from conducting until an input pin is raised at least 50 V above  $V_{CC}$  or lowered



Figure 3. Representative input protection circuit

50 V below  $V_{EE}$ . Thus, the protection networks protect the devices without constraining the allowable signal swing at the input pins. The reference (and sense) pins are protected via more conventional reverse-biased diodes which will conduct if these pins are raised above  $V_{CC}$  or below  $V_{EE}$ .

To reduce risk of damage from ESD, and to prevent RF from reaching the devices, THAT recommends the circuit of Figure 4.  $C_3$  through  $C_5$  should be located close to the point where the input signal comes into the chassis, preferably directly on the connector. The unusual circuit design is intended to minimize the unbalancing impact of differences in the values of  $C_4$  and  $C_5$  by forcing the capacitance from each input to chassis ground to depend primarily on the value of  $C_3$ . The circuit shown is approximately ten times less sensitive to mismatches between  $C_4$  and  $C_5$  than the more conventional approach in which the junction of  $C_4$  and  $C_5$  is grounded directly. An excellent discussion of input stage grounding can be found in the June 1995 issue of the *Journal of the Audio Engineering Society*, Vol. 43, No. 6, in articles by Stephen Macatee, Bill Whitlock, and others.

Note that because of the tight matching of the internal resistor ratios, coupled with the uncertainty in absolute value of any individual resistor, RF bypassing through the addition of R-C networks at the inputs (series resistor followed by a capacitor to ground at each input) is not recommended. The added resistors can interact with the internal ones in unexpected ways. If some impedance for the RF-bypass capacitor to work against is deemed necessary, THAT recommends the use of a ferrite bead or balun instead.

If it is necessary to ac-couple the inputs of the 1290-series parts, the coupling capacitors should be sized to present negligible impedance at any frequencies of interest for common mode rejection. Regardless of the type of coupling capacitor chosen, variations in the values of the two capacitors, working against the 1290-series input impedance,



Figure 4. RFI and supply bypassing

can unbalance common mode input signals. This can convert common-mode to balanced signals which will not be rejected by the CMRR of the devices. For this reason, THAT recommends dc-coupling the inputs of the 1290-series devices.

## Input Voltage Limitations

The 1290 series devices are capable of accepting input signals above the power supply rails. This is because the internal opamp's inputs connect to the outside world only through the on-chip resistors  $R_1$  through  $R_4$  at nodes a and b as shown in Figure 2. Consider the following analysis.

### Differential Input Signals

For differential signals ( $V_{IN(DIFF)}$ ), the limitation to signal handling will be output clipping. The outputs of all the devices typically clip at within 2V of the supply rails. Therefore, maximum differential input signal levels are directly related to the gain and supply rails and can be calculated in dBu as follows:

$$V_{in(diff)} = 20 \log \frac{\frac{V_{CC}-V_{EE}-2V}{2}}{0.775} - Gain$$

or

$$V_{in(diff)} = 20 \log(V_{CC} - V_{EE} - 4V) - Gain - 6.8dB$$

For example, if  $V_{CC}=15V$ ,  $V_{EE}=-15V$ , and  $Gain = -3$  dB, then

$$\begin{aligned} V_{in(diff)} &= 20 \log[15V - (-15V) - 4V] - (-3dB) - 6.8dB \\ &= 24.5 \text{ dBu} \end{aligned}$$

### Common-Mode Input Signals

For common-mode input signals, there is essentially no output signal. The limitation on common-mode handling is the point at which the inputs are overloaded. So, we must consider the inputs of the opamp.

For common-mode signals ( $V_{IN(CM)}$ ), the common-mode input current splits to flow through both  $R_1/R_2$  and through  $R_3/R_4$ . Because  $V_b$  is constrained to follow  $V_a$ , we will consider only the voltage at node a.

The voltage at a can be calculated as:

$$V_a = V_{IN(CM)} \left[ \frac{R_4}{R_3+R_4} \right]$$

Solving for  $V_{IN(CM)}$ ,

$$V_{IN(CM)} = V_a \left[ \frac{R_3+R_4}{R_4} \right]$$

For the 1290,  $(R_3 + R_4) / R_4 = 2$ . For the 1293,  $(R_3 + R_4) / R_4 = 2.4$ . For the 1296,  $(R_3 + R_4) / R_4 = 3$ . Furthermore, the same constraints apply to  $V_b$  as in the differential analysis.

Following the same reasoning as above, the maximum common-mode input signal for the 1290 is

$(2V_{CC} - 4)$  V, and the minimum is  $(2V_{EE} + 4)$  V. For the 1293, these figures are  $(2.4V_{CC} - 4.8)$  V, and  $(2.4V_{EE} + 4.8)$  V. For the 1296, these figures are  $(3V_{CC} - 6)$  V, and  $(3V_{EE} + 6)$  V.

Therefore, for common-mode signals and  $\pm 15$  V rails, the 1290 will accept up to  $\sim 26$  V in either direction. As an ac signal, this is 52 V peak-peak, 18.4 V rms, or +27.5 dBu. With the same supply rails, the 1293 will accept up to  $\sim 31$  V in either direction. As an ac signal, this is 62 V peak-peak, 21.9 V rms, or +29 dBu. With the same supply rails, the 1296 will accept up to  $\sim 39$  V in either direction. As an ac signal, this is 78 V peak-peak, 27.6 V rms, or +31 dBu.

Of course, in the real world, differential and common-mode signals combine. The maximum signal that can be accommodated will depend on the superposition of both differential and common-mode limitations.

### Output Considerations

The 1290-series devices are typically capable of supplying 42 mA into a short circuit. While they will survive a short, power dissipation will rise dramatically if the output is shorted. Junction temperature must be kept under 125 °C to maintain the devices' specifications.

These devices are stable with up to 200 pF of load capacitance over the entire rated temperature range, and even more at room temperature.

### Power Supply Considerations

The 1290-series parts are not particularly sensitive to the power supply, but they *do* contain wide bandwidth opamps. Accordingly, small local bypass capacitors should be located within a few inches of the supply pins on these parts, as shown in Figure 4.

### Selecting a Gain Variation

The three different parts offer different gain structures to suit different applications. The 1296 is customarily configured for -6 dB gain, but by reversing the resistor connections, it can also be configured for +6 dB. The 1293 is most often configured for -3 dB gain, but can also be configured for +3 dB. The choice of input gain is determined by the input voltage range to be accommodated, and the power supply voltages used within the circuit.

To minimize noise and maximize signal-to-noise ratio, the input stage should be selected and configured for the highest possible gain that will ensure that maximum-level input signals will not clip the input stage or succeeding stages. For example, with  $\pm 18$  V supply rails, the 1290-series parts have a maximum output signal swing of +23 dBu. In order to accommodate +24 dBu input signals, the maximum gain for the stage is -1 dB. With  $\pm 15$  V supply rails, the maximum output signal swing is  $\sim +21.1$  dBu; here, -3 dB is the maximum gain. In each case, a 1293 configured for -3 dB gain is the ideal choice. The 1290 (0 dB gain only) will not

provide enough headroom at its output to support a +24 dBu input signal. The 1296 (configured for -6 dB gain) attenuates the input signal an additional 3 dB, compared to 1293. Although the noise floor of 1296 is 1.5 dB lower than 1293 noise floor, the reduction in dynamic range is  $3 \text{ dB} - 1.5 \text{ dB} =$

1.5 dB. The 1296 attenuates the input signal more than necessary to support a +24 dBu input.

In fact, for most professional audio applications, THAT recommends the -3 dB input configuration possible only with the 1293 in order to preserve dynamic range within a reasonable range of power supply voltages and external headroom limits.

## Applications

The THAT 1290, 1293, and 1296 are usually thought of as precision differential amplifiers with gains of zero, -3 and -6 dB respectively. These devices are primarily intended as balanced line receivers for audio applications. However, their topology lends itself to other applications as well.

### Basic Balanced Receiver Applications

Figures 5, 6, and 7, respectively, show the 1290, 1293 and 1296 configured as zero, -3 dB, and -6 dB line receivers. Figures 8 and 9, respectively, show the 1293 and 1296 configured as +3 dB and +6 dB line receivers. The higher gains are achieved by swapping the positions of the resistors within each pair in regard to signal input vs. output.

### Precision Summing Application

Figure 10 shows a 1290 configured as a precision summing amplifier. This circuit uses both the In+ and Ref pins as inputs. Because of the good matching between the resistor pairs, the output voltage is precisely equal to the sum of the two input voltages.

### Instrumentation Amplifier Application

Figure 11 shows one half of a 1290 configured as an instrumentation amplifier. The two opamps preceding the 1290 buffer the input signal before passing it on to the 1290. The OP270 shown was chosen for its combination of good ac and dc performance. In this configuration, the opamps provide gain equal to  $1 + (9.98 \text{ k}\Omega / R_g)$  for differential signals, but unity gain for common-mode signals. The 1290 then rejects the common mode signal while passing on the differential portion. As well, the opamps buffer the input of the 1290, raising the circuit's input impedance to both differential and common-mode signals. This makes the circuit's common-mode rejection less sensitive to variations in the source impedance driving the stage.

As noted in the Theory of Operation section, THAT's InGenius® input stages use patented circuitry to increase common-mode input impedance. This even further improves common-mode rejection in real-world applications. See the THAT 1200-series datasheet for more information.

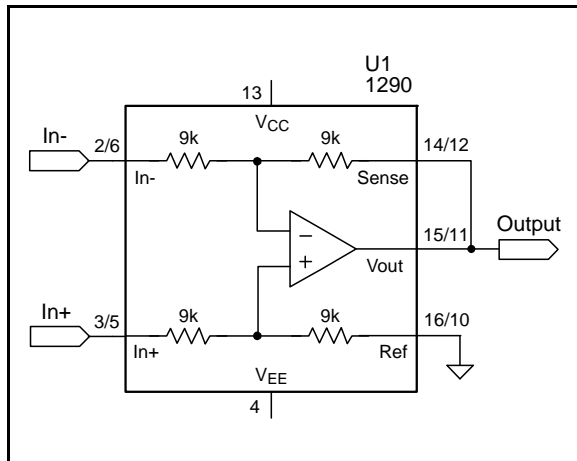

Figure 5. Zero dB line receiver

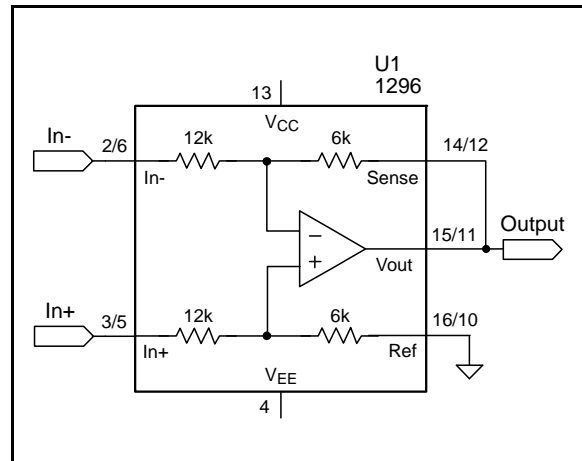

Figure 7. -6 dB line receiver

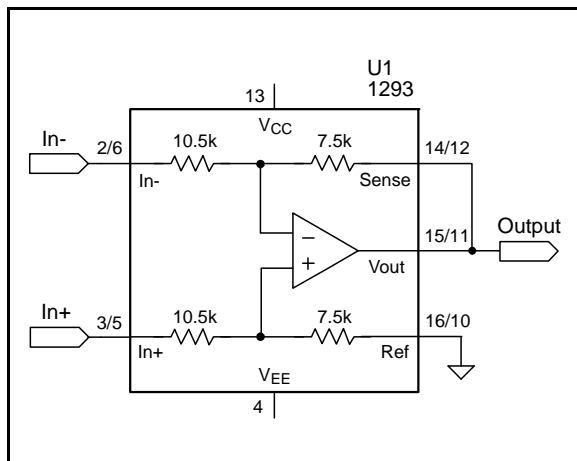

Figure 6. -3 dB line receiver

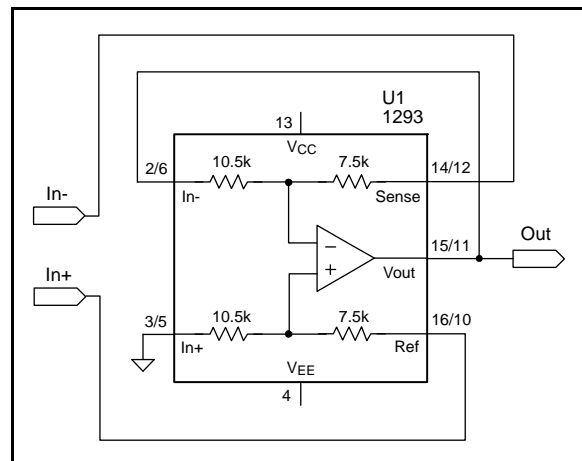

Figure 8. +3 dB line receiver

### Driving Analog-to-Digital Converters

Figure 12 shows a convenient method of driving a typical audio ADC with balanced inputs. This circuit accepts +24 dBu in. By using both halves of a single 1293 IC connected in anti-phase, the maximum signal level between their respective outputs is +27 dBu. An attenuator network brings



Figure 9. +6 dB line receiver



Figure 10. Precision two-input summing circuit



Figure 11. Instrumentation amplifier

this signal down by 18.8 dB while attenuating the noise of the line receivers as well.

In ADC applications such as this, noise is usually a significant consideration. The output noise of one channel of a THAT 1293 is -105.5 dBu in a 22 kHz bandwidth, or 27.8 nV/√Hz. Since both channels are used, and since noise adds in random fashion (square-root of the sum of the squares), the total noise level at the input of the resistive pad ( $R_1 \sim R_3$ ) will be -102.9 dBu or 37.5 nV/√Hz. The pad reduces this noise level to -121.3 dBu or 4.5 nV/√Hz at the input to the ADC, while  $C_1$  provides low-pass filtering typically required by ADCs.

The thermal noise of the resistive attenuator is 1.87 nV/√Hz or the equivalent noise of a 210 Ω resistor. Therefore, the total noise density going into the input of the ADC will be

$$e_{n \text{ ADC input}} = \sqrt{(1.87 \frac{nV}{\sqrt{Hz}})^2 + (4.5 \frac{nV}{\sqrt{Hz}})^2} = 4.87 \frac{nV}{\sqrt{Hz}}$$

The noise floor can then be calculated to be

$$\text{Noise}_{(dBu)} = 20 \log \frac{4.87 \frac{nV}{\sqrt{Hz}} \times \sqrt{22kHz}}{0.775} = -120.6 \text{ dBu}$$

### Controlling Gain in Balanced Systems

When it becomes necessary to control gain in a balanced system, designers are often tempted to keep the signal balanced and use two Voltage Controlled Amplifiers (VCAs) to control the gain on each half of the balanced signal. Unfortunately, this can result in common-mode to differential-mode conversion (degrading CMRR) when there are even slight differences in gain between the VCAs. A better approach is to convert the signal to single-ended, alter the gain, and then convert back to balanced.

Figure 13 shows a stereo gain control for a balanced system. First, we use a 1293 -3 dB line receiver to perform the balanced to single-ended conversion. A THAT 1606, with +6dB gain, is used to rebalance the signal before the circuit's output. A THAT 2162 dual VCA is used to alter gain based on a dc voltage applied at  $E_c$ , the "Control Voltage" node. (This point is intended to be driven from a low-impedance, low-noise voltage source. See the THAT 2162-series data sheet for details.)

As shown, the VCA section is configured for "static" gain of -3 dB (gain with 0 Vdc applied to the  $E_c$ ) due to the choice of ratio of  $R_3$  to  $R_2$  and  $R_7$  to  $R_6$ . Additionally, the 1293 has a gain of -3 dB for a total attenuation of 6 dB before the output driver. The 1606 has a gain of 6 dB, therefore the circuit has a gain of 0 dB with 0 V at the control voltage node.

This circuit accepts and delivers over +24 dBu before clipping, and has a noise floor of -91.5 dBu (22 kHz bandwidth). By varying the Control Voltage, gains from -70 dB to +40 dB may easily be achieved. The VCA's "deci-linear" relationship between Control Voltage and gain makes the gain setting precise, predictable, and repeatable.





Figure 12. Circuit for audio ADCs with balanced inputs



Figure 13. Voltage-controlled gain control of a balanced signal

## Package Information

The THAT1290 series is available in a 16-pin QSOP package. Package dimensions are shown in Figure 14 below; Pinouts are given in Table 1 on page 1. Ordering information is provided in Table 2 below.

The 1290 series package is entirely lead-free. The lead-frame is copper, plated with successive layers of nickel, palladium, and gold. This approach makes it possible to solder these devices using lead-free and lead-bearing solders.

Neither the lead-frame nor the plastic mold compound used in the 1290-series contains any hazardous substances as specified in the European Union's *Directive on the Restriction of the Use of Certain Hazardous Substances in Electrical and Electronic Equipment 2002/95/EG* of January 27, 2003.

The surface-mount package is suitable for use in a 100% tin solder process.

<b>Package Characteristics</b>						
Parameter	Symbol	Conditions	Min	Typ	Max	Units
Package Style		See Fig. 14 for dimensions	16 Pin QSOP			
Thermal Resistance	$\theta_{JA}$	QSOP package soldered to board		115		$^{\circ}\text{C}/\text{W}$
Environmental Regulation Compliance		Complies with January 27, 2003 RoHS requirements				
Soldering Reflow Profile		JEDEC JESD22-A113-D (250 $^{\circ}\text{C}$ )				
Moisture Sensitivity Level	MSL	Above-referenced JEDEC soldering profile		1		



Figure 14. 16-pin QSOP package outline

Gain	Order Number
0 dB	1290Q16-U
$\pm 3$ dB	1293Q16-U
$\pm 6$ dB	1296Q16-U

Table 2. Ordering information

Компания «Life Electronics» занимается поставками электронных компонентов импортного и отечественного производства от производителей и со складов крупных дистрибьюторов Европы, Америки и Азии.

С конца 2013 года компания активно расширяет линейку поставок компонентов по направлению коаксиальный кабель, кварцевые генераторы и конденсаторы (керамические, пленочные, электролитические), за счёт заключения дистрибьюторских договоров

Мы предлагаем:

- Конкуренспособные цены и скидки постоянным клиентам.
- Специальные условия для постоянных клиентов.
- Подбор аналогов.
- Поставку компонентов в любых объемах, удовлетворяющих вашим потребностям.
- Приемлемые сроки поставки, возможна ускоренная поставка.
- Доставку товара в любую точку России и стран СНГ.
- Комплексную поставку.
- Работу по проектам и поставку образцов.
- Формирование склада под заказчика.
- Сертификаты соответствия на поставляемую продукцию (по желанию клиента).
- Тестирование поставляемой продукции.
- Поставку компонентов, требующих военную и космическую приемку.
- Входной контроль качества.
- Наличие сертификата ISO.

В составе нашей компании организован Конструкторский отдел, призванный помогать разработчикам, и инженерам.

Конструкторский отдел помогает осуществить:

- Регистрацию проекта у производителя компонентов.
- Техническую поддержку проекта.
- Защиту от снятия компонента с производства.
- Оценку стоимости проекта по компонентам.
- Изготовление тестовой платы монтаж и пусконаладочные работы.



Тел: +7 (812) 336 43 04 (многоканальный)

Email: [org@lifeelectronics.ru](mailto:org@lifeelectronics.ru)