

PmodSF2™ Memory Module Reference Manual



1300 NE Henley Court, Suite 3
Pullman, WA 99163
(509) 334 6306 Voice | (509) 334 6300 Fax

Revision: February 8, 2012

Overview

The PmodSF2 is a peripheral module that provides 128Mbit (16Mbyte) of serial phase change memory (PCM). This memory is accessed through a legacy SPI (serial peripheral interface) compatible serial interface.

Features include:

- Micron P5Q PCM
128Mbit, Quad/Dual/Single Serial Interface
- a 12-pin header Pmod interface connector
- more than 1,000,000 write cycles
- high program performance with low power
- small form factor (0.80" x 1.00")

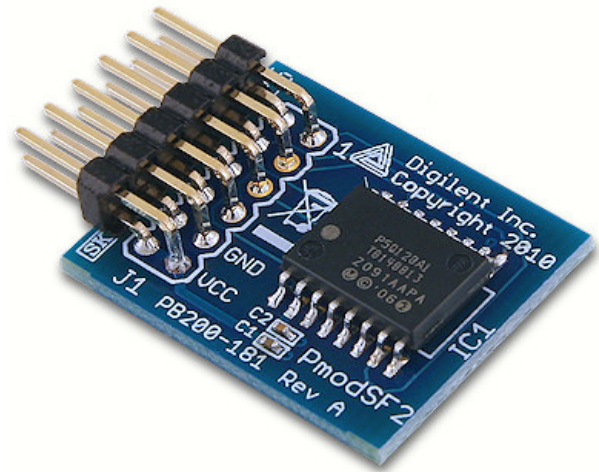

SPI Header

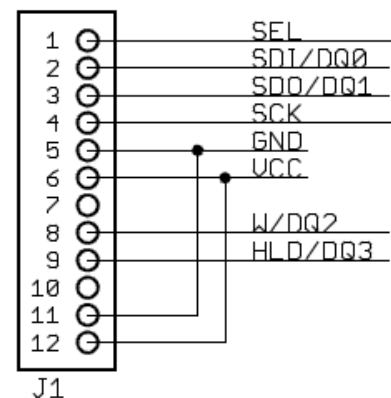

Block Diagram

Functional Description

The PmodSF2 is used for easily-accessible non-volatile memory storage for various Digilent programmable-logic and embedded-control system boards.

Note: The PmodSF2 is intended for direct connection to boards with 12-pin Pmod headers only. It is not intended for use with Pmod cables.

The flash memory on the PmodSF2 is provided by a Micron P5Q PCM integrated circuit. This memory is organized as 128 sectors of 131,072 (128K) bytes each. Each sector is organized as 1024 pages of 128 bytes each.

Flash memory must be erased before new data can be written. The P5Q PCM supports byte alterability, which allows direct overwrite and eliminates erase operation. For legacy compatibility, P5Q PCM supports emulated erase operation. P5Q allows for a bulk erase or

erase of individual sectors. After a sector has been erased, individual bytes within the sector can be written as well as complete pages. The entire memory can be written as a single write operation.

Flash memory will eventually wear out after many erase/program cycles. The P5Q PCM supports more than 1,000,000 erase/program cycles per sector before the memory wears out. Flash memory wear-out is usually not an issue in routine operation but bugs in the control software can cause many erase/program cycles to happen quickly.

The legacy SPI interface standard uses four signal lines. These are SS, slave select; MOSI, master out slave in; MISO, master in slave out; and SCK, serial clock. These signals map to the following signals on the P5Q PCM part as described in the Micron datasheet: SS

corresponds to the Chip Select signal (\overline{S}), MOSI corresponds to Serial Data Input (D), MISO corresponds to Serial Data Output (Q), and SCK corresponds to the Serial Clock signal (C). See the Micron datasheet for descriptions of the Dual and Quad modes of operation, as well as the use of the Write Protect (\overline{W}) and Hold (\overline{HLD}) signals.

A system board interacts with the PmodSF2 module by sending commands over the SPI interface. Depending on the command sent, the system board sends memory data to, or receives memory data from, the module.

The P5Q PCM provides commands to perform sector erase, bulk erase, page program, and write commands as well as other miscellaneous commands.

Refer to the Micron P5Q PCM IC data sheet for detailed information on the operation of this integrated circuit.

The PmodSF2 requires a 2.7V- 3.6V supply voltage. This power supply voltage (3.3V) is available on all Digilent system boards and is provided as part of the 12-wire Pmod interface standard. Digilent system boards that provide Pmod interface connectors allow jumper selection of the power supply voltage being provided to the Pmod. Ensure that the system board is jumpered to provide 3.3V to the module before applying power to the board.

For detailed information on the P5Q PCM, see the Micron data sheet provided on the PmodSF2 product page.

Connector J1 Signals

Pin	Signal
1	SS (\overline{S})
2	MOSI (D/DQ0)
3	MISO (Q/DQ1)
4	SCK (C)
5	GND
6	VCC
7	Not Used
8	\overline{W} /DQ2
9	\overline{HLD} /DQ3
10	Not Used
11	GND
12	VCC

Компания «Life Electronics» занимается поставками электронных компонентов импортного и отечественного производства от производителей и со складов крупных дистрибьюторов Европы, Америки и Азии.

С конца 2013 года компания активно расширяет линейку поставок компонентов по направлению коаксиальный кабель, кварцевые генераторы и конденсаторы (керамические, пленочные, электролитические), за счёт заключения дистрибьюторских договоров

Мы предлагаем:

- Конкурентоспособные цены и скидки постоянным клиентам.
- Специальные условия для постоянных клиентов.
- Подбор аналогов.
- Поставку компонентов в любых объемах, удовлетворяющих вашим потребностям.
- Приемлемые сроки поставки, возможна ускоренная поставка.
- Доставку товара в любую точку России и стран СНГ.
- Комплексную поставку.
- Работу по проектам и поставку образцов.
- Формирование склада под заказчика.
- Сертификаты соответствия на поставляемую продукцию (по желанию клиента).
- Тестирование поставляемой продукции.
- Поставку компонентов, требующих военную и космическую приемку.
- Входной контроль качества.
- Наличие сертификата ISO.

В составе нашей компании организован Конструкторский отдел, призванный помогать разработчикам, и инженерам.

Конструкторский отдел помогает осуществить:

- Регистрацию проекта у производителя компонентов.
- Техническую поддержку проекта.
- Защиту от снятия компонента с производства.
- Оценку стоимости проекта по компонентам.
- Изготовление тестовой платы монтаж и пусконаладочные работы.



Тел: +7 (812) 336 43 04 (многоканальный)

Email: org@lifeelectronics.ru