

General Specifications

Electrical Capacity (Resistive Load)

Power Level (silver):	3VA maximum @ 28V DC maximum (Applicable Range 10mA ~ 125mA @ 0.1V ~ 28V)
Logic Level (gold):	0.4VA maximum @ 28V AC/DC maximum (Applicable Range 0.1mA ~ 0.1A @ 20mV ~ 28V)
	Note: See Supplement for further explanation of operating range.

Other Ratings

Contact Resistance:	100 milliohms maximum
Insulation Resistance:	100 megohms minimum @ 100V DC
Dielectric Strength:	250V AC minimum for 1 minute minimum between contacts & between contacts & case
Mechanical Life:	500,000 operations minimum
Electrical Life:	500,000 operations minimum
Nominal Operating Force:	1.60N
Total Travel:	.008" (0.2mm)

Materials & Finishes

Actuator:	Glass fiber reinforced polyamide (UL94V-0)
Case:	Stainless steel
Base:	Glass fiber reinforced polyamide (UL94V-0)
Movable Contacts:	Stainless steel with silver or gold plating
Stationary Contacts:	Brass with silver or gold plating
Terminals:	Brass with silver or gold plating

Environmental Data

Operating Temperature Range:	-20°C through +70°C (-4°F through +158°F)
Humidity:	90 ~ 95% humidity for 240 hours @ 40°C (104°F)
Vibration:	10 ~ 55Hz with peak-to-peak amplitude of 1.5mm traversing the frequency range & returning in 1 minute; 3 right angled directions for 2 hours
Shock:	100G (981m/s ²) acceleration (tested in 6 right angled directions, with 5 shocks in each direction)

PCB Processing

Soldering:	Wave Soldering Recommended. See Profile A in Supplement section. Manual Soldering: See Profile A in Supplement section.
Cleaning:	These devices are not process sealed. Hand clean locally using alcohol based solution.

Standards & Certifications

Flammability Standards:	UL94V-0 actuator and base These switches are designed for use in a low-voltage, low-current circuit. When used as intended, the results do not produce hazardous energy.
--------------------------------	--

Distinctive Characteristics

.244" (6.2mm) square body allows compact mounting.

Heat resistant resin body meets lead-free solder processing requirements and UL flammability rating of 94V-0.

Stick-tube packaging allows rapid automated placement of devices.

Gold plated contacts available for very low voltage/current applications offer advantages of little or no oxidization or sulfurization and stable contact resistance.

Crimped terminals provide a spring type action which ensures secure mounting and prevents dislodging during automated soldering.

Insert molded terminals lock out flux, solvents, and other contaminants and allow automated soldering.

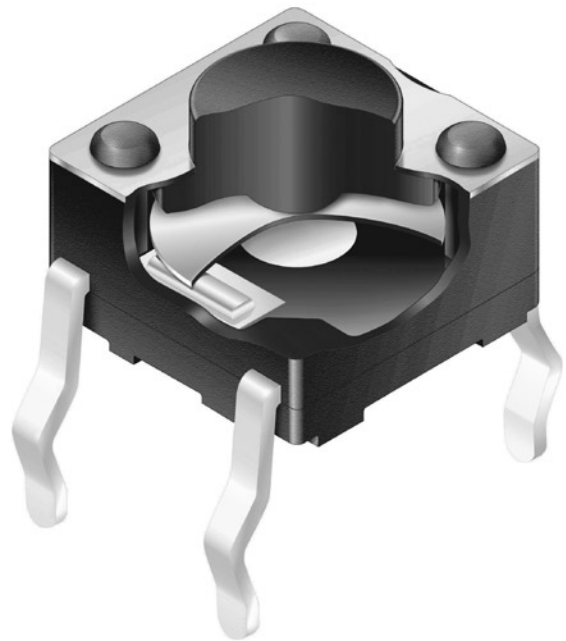

Actual Size

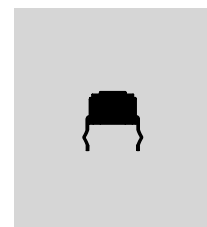

TYPICAL SWITCH ORDERING EXAMPLE

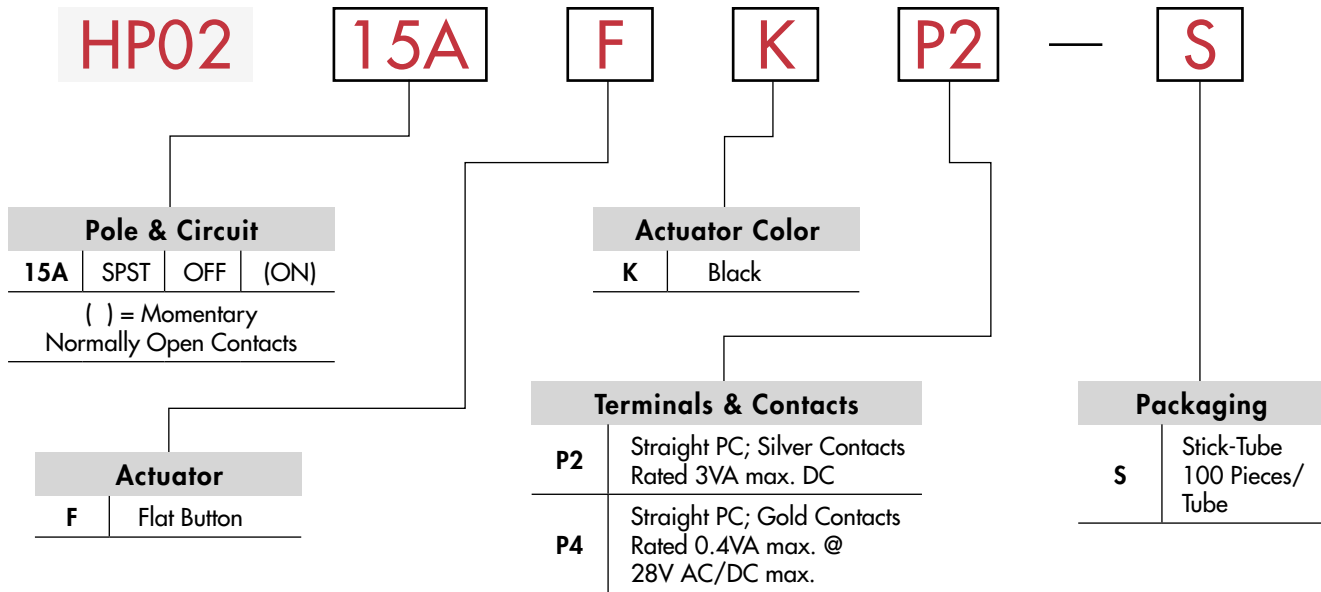

DESCRIPTION FOR TYPICAL ORDERING EXAMPLE

HP0215AFKP2-S

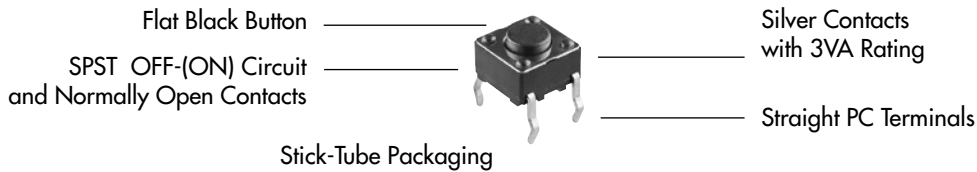

POLE & CIRCUIT

		Actuator Position () = Momentary		Switch Throw & Schematic	Note: Terminal numbers are not actually on the switch.
Pole	Model	Normal	Down	SPST	
SP	HP0215A	OFF	(ON)		

TYPICAL SWITCH DIMENSIONS

Straight PC



HP0215AFKP2

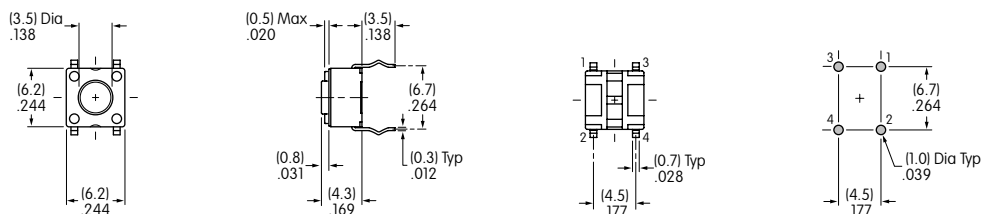

PACKAGING

S

Stick-Tube

Switches must be ordered in 100-piece increments.

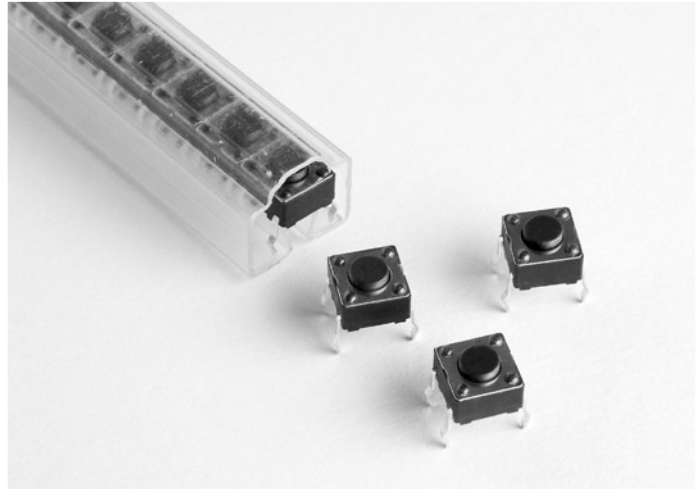

Stick-Tube Dimensions

Each stick-tube contains 100 switches.

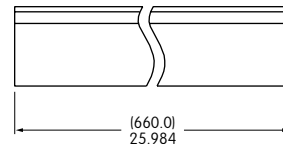
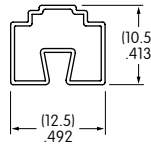

KEYBOARD MATRIX

Common Bus Matrix

These single pole, single throw switches can be used in a keyboard matrix and, using strapped terminals, achieve a common bus electrical configuration on a single-sided PC board.

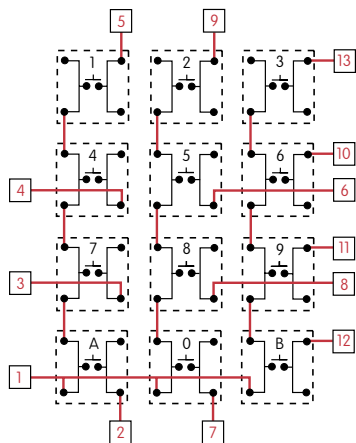

		PC Terminations												
		1	2	3	4	5	6	7	8	9	10	11	12	13
Keys (Switches)	1					●								
	2										●			
	3													●
	4													
	5													
	6													
	7													
	8													
	9													
	0													
	A													
	B													

● = ON

X-Y Matrix

These single pole, single throw switches can be arranged on a single-sided PC board matrix with strapped terminals to achieve an X-Y type electrical interconnection.

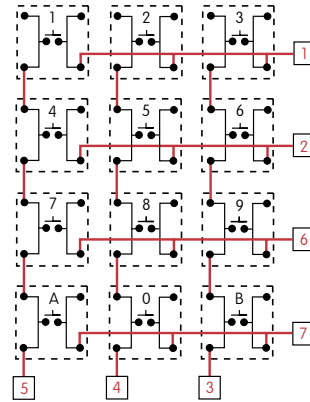

		PC Terminations						
		1	2	3	4	5	6	7
Keys (Switches)	1					●		
	2							
	3							
	4							
	5							
	6							
	7							

● = ON

Red = PCB Trace Black = Switch Circuit

Компания «Life Electronics» занимается поставками электронных компонентов импортного и отечественного производства от производителей и со складов крупных дистрибьюторов Европы, Америки и Азии.

С конца 2013 года компания активно расширяет линейку поставок компонентов по направлению коаксиальный кабель, кварцевые генераторы и конденсаторы (керамические, пленочные, электролитические), за счёт заключения дистрибьюторских договоров

Мы предлагаем:

- Конкурентоспособные цены и скидки постоянным клиентам.
- Специальные условия для постоянных клиентов.
- Подбор аналогов.
- Поставку компонентов в любых объемах, удовлетворяющих вашим потребностям.
- Приемлемые сроки поставки, возможна ускоренная поставка.
- Доставку товара в любую точку России и стран СНГ.
- Комплексную поставку.
- Работу по проектам и поставку образцов.
- Формирование склада под заказчика.
- Сертификаты соответствия на поставляемую продукцию (по желанию клиента).
- Тестирование поставляемой продукции.
- Поставку компонентов, требующих военную и космическую приемку.
- Входной контроль качества.
- Наличие сертификата ISO.

В составе нашей компании организован Конструкторский отдел, призванный помогать разработчикам, и инженерам.

Конструкторский отдел помогает осуществить:

- Регистрацию проекта у производителя компонентов.
- Техническую поддержку проекта.
- Защиту от снятия компонента с производства.
- Оценку стоимости проекта по компонентам.
- Изготовление тестовой платы монтаж и пусконаладочные работы.



Тел: +7 (812) 336 43 04 (многоканальный)

Email: org@lifeelectronics.ru