

TPD1030F

2-IN-1 Low-Side Switch for Motor, Solenoid and Lamp Drive

The TPD1030F is a 2-IN-1 low-side switch.

The IC has a vertical MOSFET output which can be directly driven from a CMOS or TTL logic circuit (e.g., an MPU). The IC is equipped with intelligent self-protection functions.

Features

- Two built-in power IC chips with a new structure combining a control block and a vertical power MOSFET (L^2 - π -MOS) on each chip.
- Can directly drive a power load from a CMOS or TTL logic.
- Built-in protection circuits against overvoltage (active clamp), overtemperature (thermal shutdown), and overcurrent (current limiter).
- Low Drain-Source ON-resistance: $R_{DS(ON)} = 0.6 \Omega$ (max) (@ $V_{IN} = 5 \text{ V}$, $I_D = 0.5 \text{ A}$, $T_{ch} = 25^\circ\text{C}$)
- Low Leakage Current: $I_{DSS} = 10 \mu\text{A}$ (max) (@ $V_{IN} = 0 \text{ V}$, $V_{DS} = 30 \text{ V}$, $T_{ch} = 25^\circ\text{C}$)
- Low Input Current: $I_{IN} = 300 \mu\text{A}$ (max) (@ $V_{IN} = 5 \text{ V}$, $T_{ch} = 25^\circ\text{C}$)
- 8-pin SOP package with embossed-tape packaging.

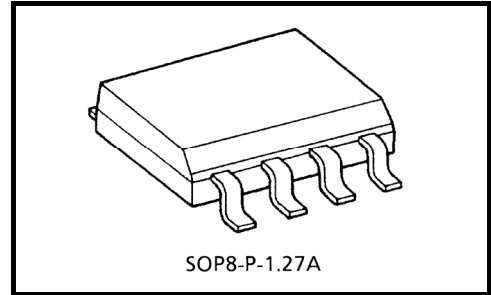

Weight: 0.08 g (typ.)

Pin Assignment (top view)

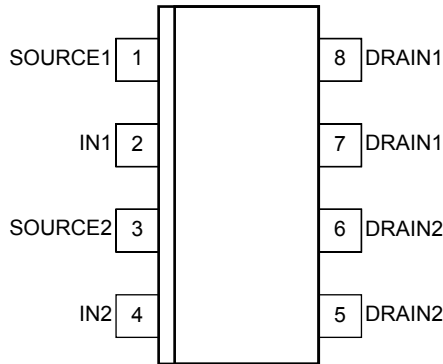

Marking

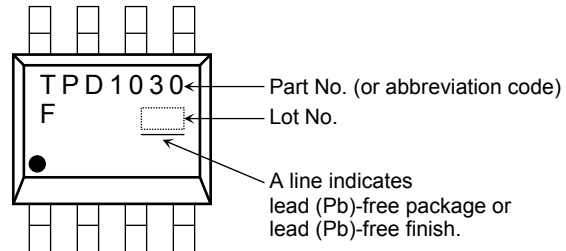

Note1: Due to its MOS structure, this product is sensitive to static electricity.

Block Diagram

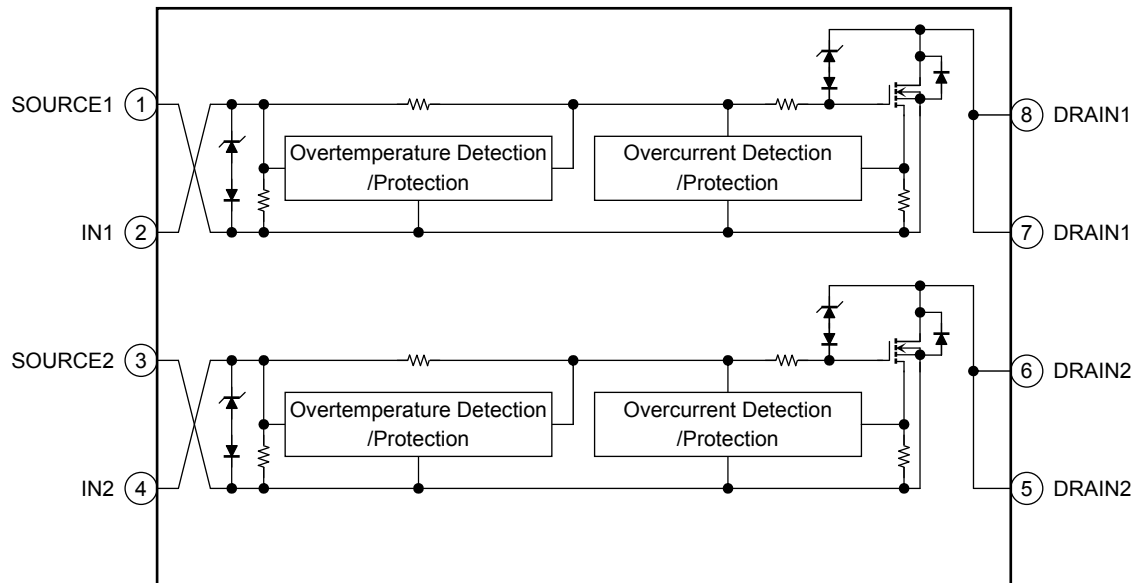

Pin Description

Pin No.	Symbol	Pin Description
1	SOURCE1	Source pin 1
2	IN1	Input pin 1 This pin is connected to a pull-down resistor internally, so that even when input wiring is open-circuited, output can never be turned on inadvertently.
3	SOURCE2	Source pin 2
4	IN2	Input pin 2 This pin is connected to a pull-down resistor internally, so that even when input wiring is open-circuited, output can never be turned on inadvertently.
5, 6	DRAIN2	Drain pin 2 Drain current is limited (by current limiter) if it exceeds 1 A (min) in order to protect the IC.
7, 8	DRAIN1	Drain pin 1 Drain current is limited (by current limiter) if it exceeds 1 A (min) in order to protect the IC.

Timing Chart

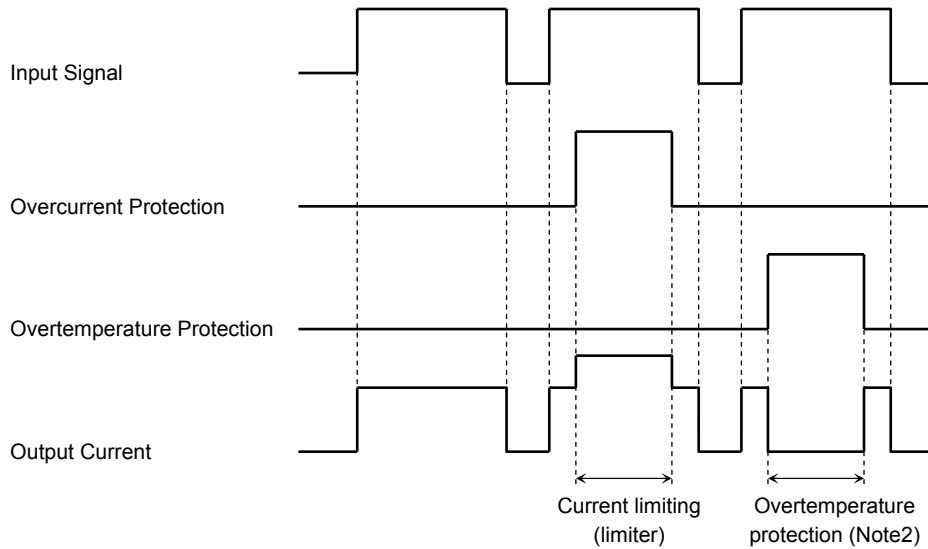

Note2: The overheating detector circuits feature hysteresis. After overheating is detected, normal operation is restored only when the channel temperature falls by the hysteresis amount (5°C typ.) in relation to the overheating detection temperature.

Truth Table

IN	V _{OUT}	Mode
L	H	Normal
H	L	
L	H	Overcurrent
H	H	
L	H	Overtemperature
H	H	

Absolute Maximum Ratings (Ta = 25°C)

Characteristics	Symbol	Rating	Unit
Drain-source voltage	V _{DS} (DC)	40	V
Drain current	I _D	Internally Limited	A
Input voltage	V _{IN}	-0.3 to 7	V
Power dissipation (t = 10 s)	P _D	2.0 (Note 3)	W
Single pulse active clamp capability (Note 4)	E _{AS}	10	mJ
Active clamp current	I _{AR}	1	A
Repetitive active clamp capability (Note 5)	E _{AR}	0.2	mJ
Operating temperature	T _{opr}	-40 to 110	°C
Channel temperature	T _{ch}	150	°C
Storage temperature	T _{stg}	-55 to 150	°C

Note: Using continuously under heavy loads (e.g. the application of high temperature/current/voltage and the significant change in temperature, etc.) may cause this product to decrease in the reliability significantly even if the operating conditions (i.e. operating temperature/current/voltage, etc.) are within the absolute maximum ratings and the operating ranges.

Please design the appropriate reliability upon reviewing the Toshiba Semiconductor Reliability Handbook ("Handling Precautions"/Derating Concept and Methods) and individual reliability data (i.e. reliability test report and estimated failure rate, etc).

Thermal Characteristics

Characteristics	Symbol	Max	Unit
Thermal resistance, channel to ambient (t = 10 s) (Note3)	$R_{th} (ch-a)$	62.5	°C/W

Note 3: Drive operation: Mounted on glass epoxy board [25.4mm × 25.4mm × 0.8mm] (with the two devices operating)

Note 4: Active clamp capability (single pulse) test condition
 $V_{DD} = 25 V$, Starting $T_{ch} = 25^{\circ}C$, $L = 10 mH$, $I_{AR} = 1 A$, $R_G = 25 \Omega$

Note 5: Repetitive rating, pulse width limited by maximum channel temperature.

Electrical Characteristics

Characteristics	Symbol	Test Circuit	Test Condition	Min	Typ.	Max	Unit	
Drain-source clamp voltage	$V_{(CL) DSS}$	—	$T_{ch} = -40 \sim 110^{\circ}C$ $V_{IN} = 0 V$, $I_D = 1 mA$	40	—	60	V	
Input threshold voltage	V_{th}	—	$T_{ch} = 25^{\circ}C$	1.0	—	2.8	V	
			$T_{ch} = -40 \sim 110^{\circ}C$					0.9
Protective circuit operation input voltage range	$V_{IN (opr)}$	—	$T_{ch} = 25^{\circ}C$	—	—	7	V	
			$T_{ch} = -40 \sim 110^{\circ}C$	—	—	7		
Drain cut-off current	I_{DSS}	—	$T_{ch} = 25^{\circ}C$	$V_{IN} = 0 V$, $V_{DS} = 30V$	—	—	10	μA
			$T_{ch} = -40 \sim 110^{\circ}C$		—	—	100	
Input current	$I_{IN (1)}$	—	$T_{ch} = 25^{\circ}C$	$V_{IN} = 5 V$, at normal operation	—	—	300	μA
	$I_{IN (2)}$	—	$T_{ch} = -40 \sim 110^{\circ}C$	$V_{IN} = 5 V$, when overcurrent protective circuit is actuated	—	—	350	
Drain-source on resistance	$R_{DS (ON)}$	—	$T_{ch} = 25^{\circ}C$	$V_{IN} = 5 V$, $I_D = 0.5 A$	—	0.44	0.6	Ω
			$T_{ch} = -40 \sim 110^{\circ}C$		—	—	0.9	
Overtemperature protection	T_S	—	—	$V_{IN} = 5 V$	150	160	—	°C
Overcurrent protection	I_S	—	$T_{ch} = 25^{\circ}C$	$V_{IN} = 5 V$	1	1.8	—	A
			$T_{ch} = -40 \sim 110^{\circ}C$		0.7	—	—	
Switching time	t_{ON}	1	$T_{ch} = 25^{\circ}C$	$V_{DD} = 13 V$, $V_{IN} = 0V/5 V$, $I_D = 0.5 A$	—	—	30	μs
			$T_{ch} = -40 \sim 110^{\circ}C$		—	—	60	
	$T_{ch} = 25^{\circ}C$		—		—	60		
	$T_{ch} = -40 \sim 110^{\circ}C$		—		—	90		
Source-drain diode forward voltage	V_{DSF}	—	$T_{ch} = 25^{\circ}C$	$I_F = 1 A$, $V_{IN} = 0 V$	—	—	1.7	V

Test Circuit 1

Switching time measuring circuit

Test Circuit

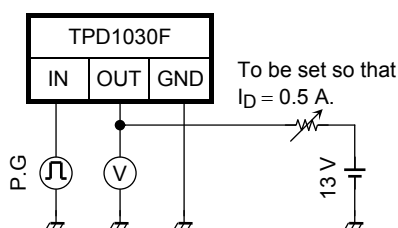

Measured Waveforms

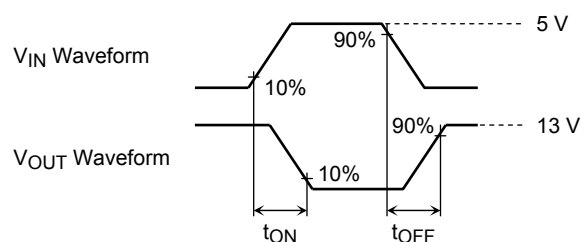

Package Dimensions

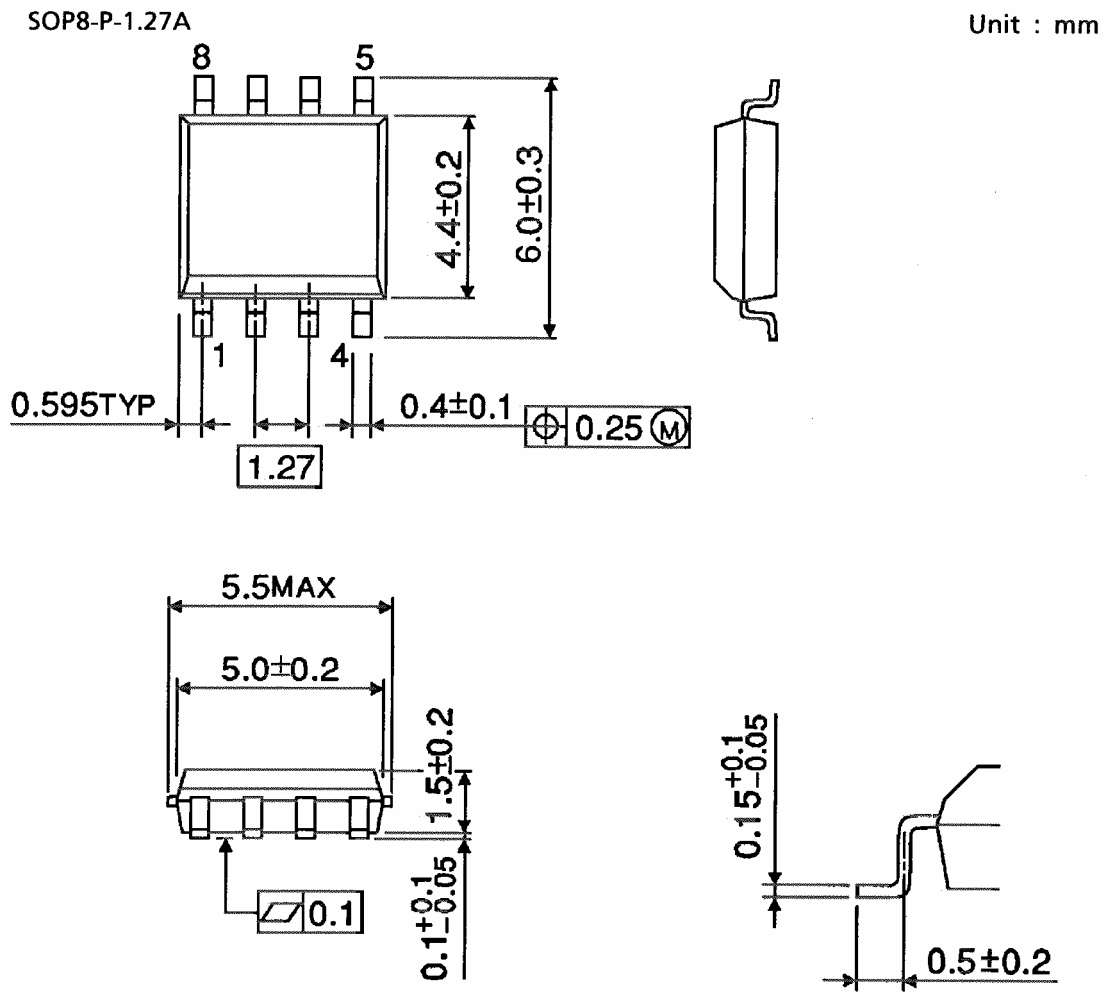

Weight: 0.08 g (typ.)

RESTRICTIONS ON PRODUCT USE

20070701-EN

- The information contained herein is subject to change without notice.
- TOSHIBA is continually working to improve the quality and reliability of its products. Nevertheless, semiconductor devices in general can malfunction or fail due to their inherent electrical sensitivity and vulnerability to physical stress. It is the responsibility of the buyer, when utilizing TOSHIBA products, to comply with the standards of safety in making a safe design for the entire system, and to avoid situations in which a malfunction or failure of such TOSHIBA products could cause loss of human life, bodily injury or damage to property.
In developing your designs, please ensure that TOSHIBA products are used within specified operating ranges as set forth in the most recent TOSHIBA products specifications. Also, please keep in mind the precautions and conditions set forth in the "Handling Guide for Semiconductor Devices," or "TOSHIBA Semiconductor Reliability Handbook" etc.
- The TOSHIBA products listed in this document are intended for usage in general electronics applications (computer, personal equipment, office equipment, measuring equipment, industrial robotics, domestic appliances, etc.). These TOSHIBA products are neither intended nor warranted for usage in equipment that requires extraordinarily high quality and/or reliability or a malfunction or failure of which may cause loss of human life or bodily injury ("Unintended Usage"). Unintended Usage include atomic energy control instruments, airplane or spaceship instruments, transportation instruments, traffic signal instruments, combustion control instruments, medical instruments, all types of safety devices, etc.. Unintended Usage of TOSHIBA products listed in this document shall be made at the customer's own risk.
- The products described in this document shall not be used or embedded to any downstream products of which manufacture, use and/or sale are prohibited under any applicable laws and regulations.
- The information contained herein is presented only as a guide for the applications of our products. No responsibility is assumed by TOSHIBA for any infringements of patents or other rights of the third parties which may result from its use. No license is granted by implication or otherwise under any patents or other rights of TOSHIBA or the third parties.
- Please contact your sales representative for product-by-product details in this document regarding RoHS compatibility. Please use these products in this document in compliance with all applicable laws and regulations that regulate the inclusion or use of controlled substances. Toshiba assumes no liability for damage or losses occurring as a result of noncompliance with applicable laws and regulations.

Компания «Life Electronics» занимается поставками электронных компонентов импортного и отечественного производства от производителей и со складов крупных дистрибьюторов Европы, Америки и Азии.

С конца 2013 года компания активно расширяет линейку поставок компонентов по направлению коаксиальный кабель, кварцевые генераторы и конденсаторы (керамические, пленочные, электролитические), за счёт заключения дистрибьюторских договоров

Мы предлагаем:

- Конкурентоспособные цены и скидки постоянным клиентам.
- Специальные условия для постоянных клиентов.
- Подбор аналогов.
- Поставку компонентов в любых объемах, удовлетворяющих вашим потребностям.
- Приемлемые сроки поставки, возможна ускоренная поставка.
- Доставку товара в любую точку России и стран СНГ.
- Комплексную поставку.
- Работу по проектам и поставку образцов.
- Формирование склада под заказчика.
- Сертификаты соответствия на поставляемую продукцию (по желанию клиента).
- Тестирование поставляемой продукции.
- Поставку компонентов, требующих военную и космическую приемку.
- Входной контроль качества.
- Наличие сертификата ISO.

В составе нашей компании организован Конструкторский отдел, призванный помогать разработчикам, и инженерам.

Конструкторский отдел помогает осуществить:

- Регистрацию проекта у производителя компонентов.
- Техническую поддержку проекта.
- Защиту от снятия компонента с производства.
- Оценку стоимости проекта по компонентам.
- Изготовление тестовой платы монтаж и пусконаладочные работы.



Тел: +7 (812) 336 43 04 (многоканальный)

Email: org@lifeelectronics.ru