

NOTES:

△ PART NUMBER VARIABLES: NOT ALL POSSIBLE CONFIGURATIONS SHOWN ON THIS DRAWING ARE AVAILABLE AS STANDARD PRODUCTS. PLEASE CHECK WITH RAYCHEM TO CONFIRM AVAILABILITY.

THIS FIELD OF NUMBERS IS REPLACED BY 3 DIGITS (-001 / -999) FOR SPECIALS

MODIFICATIONS: REFER TO APPLICABLE MOD DESCRIPTION SHEET. "BLANK WHEN NOT APPLICABLE"

POST CONFIGURATIONS: 1 = LONG POST, 2 = SHORT POST, 3 = POST BENT 90° "B" DIRECTION

FINISH: 2 = NICKEL PLATED, 3 = CADMIUM OVER NICKEL PLATED

SIZE: 1 = 1 INCH, 2 = 2 INCH

STYLE: C = FLANGED WITH CONDUCTIVE PANEL GASKET AND EXTERNAL MOUNTING HARDWARE, D = FLANGED WITH FLUROSILICONE PANEL GASKET AND EXTERNAL MOUNTING HARDWARE, F = FLANGED WITH FLUROSILICONE PANEL GASKET, S = FLANGED WITH CONDUCTIVE PANEL GASKET, Y = SPECIAL (REFER TO INDIVIDUAL SPECIFICATION CONTROL DRAWINGS FOR DESCRIPTIONS)

2. A SOCKET BOXMOUNT RECEPTACLE MATES WITH A MTC PLUG CONTAINING PIN INSERTS. REFER TO APPLICABLE RAYCHEM SPECIFICATION CONTROL DRAWINGS FOR DETAILS.

△ FOR KEYING INFORMATION, SEE RAYCHEM DRAWING D-659-0080.

△ THESE ITEMS ARE SUPPLIED UNASSEMBLED.

△ DIMENSION SHOWN IS WITH MATED PLUG CONNECTOR: a. WITH CABLE CLAMP, b. WITHOUT CABLE CLAMP AND WITHOUT EARS

△ THIS BOXMOUNT RECEPTACLE IS REAR PANEL MOUNTED AS SHOWN BY REMOVING AS MANY PANEL WASHERS AS REQUIRED TO ACCOMMODATE THE THICKNESS OF THE PANEL BEING USED. REFER TO SHEET 3, FIGURE 4 AND TABLE 2.

△ WIRE WRAPPABLE TERMINATION POST DESIGNED TO MIL-STD-1130.

△ KIT NUMBER CHA-0046-XXX IS AVAILABLE FOR MOUNTING A CONNECTOR TO A PRINTED CIRCUIT BOARD. SEE SHEET 3, FIGURE 3 FOR THE HOLE PATTERN RECOMMENDATION.

△ SEE SHEET 3, TABLE 3 FOR WEIGHTS. WEIGHTS SHOWN ARE WITHOUT DUST CAP AND WITHOUT TERMINATION POST PROTECTOR.

△ SEE SHEET 2 FIGURES FOR CONFIGURATION VARIATIONS.

△ TORQUE MOUNTING HARDWARE TO: 14-16 IN-LBS

If this document is printed it becomes uncontrolled. Check with the web for latest revision.

Table with 3 columns: LTR, DESCRIPTION, DATE, APPROVED. Rows include revisions G (REVISED PER ECN T-17996) and H (REDRAWN ON CAD PER ECN T-22751).

1" STANDARD INSERT ASSEMBLY SHOWN

POST PROTECTOR (REMOVE PRIOR TO TERMINATION)

1" INSERT CONTACT IDENTIFICATION SHOWN

MOUNTING PANEL

APPLICABLE PART NUMBER (NUMBER SHOWN IS FOR REF. ONLY)

PANEL THICKNESS: 0.097 [2.46] MAX., 0.031 [0.79] MIN.

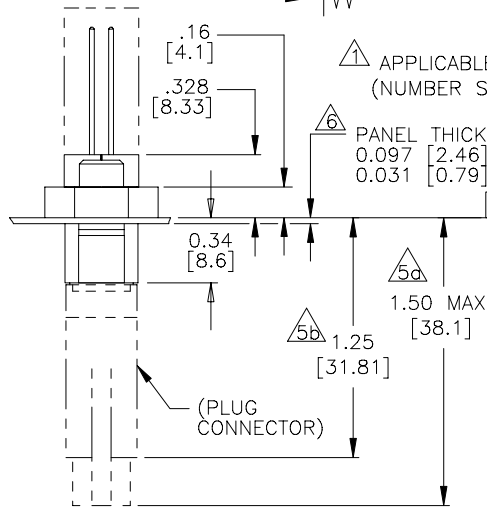

VIEW W-W

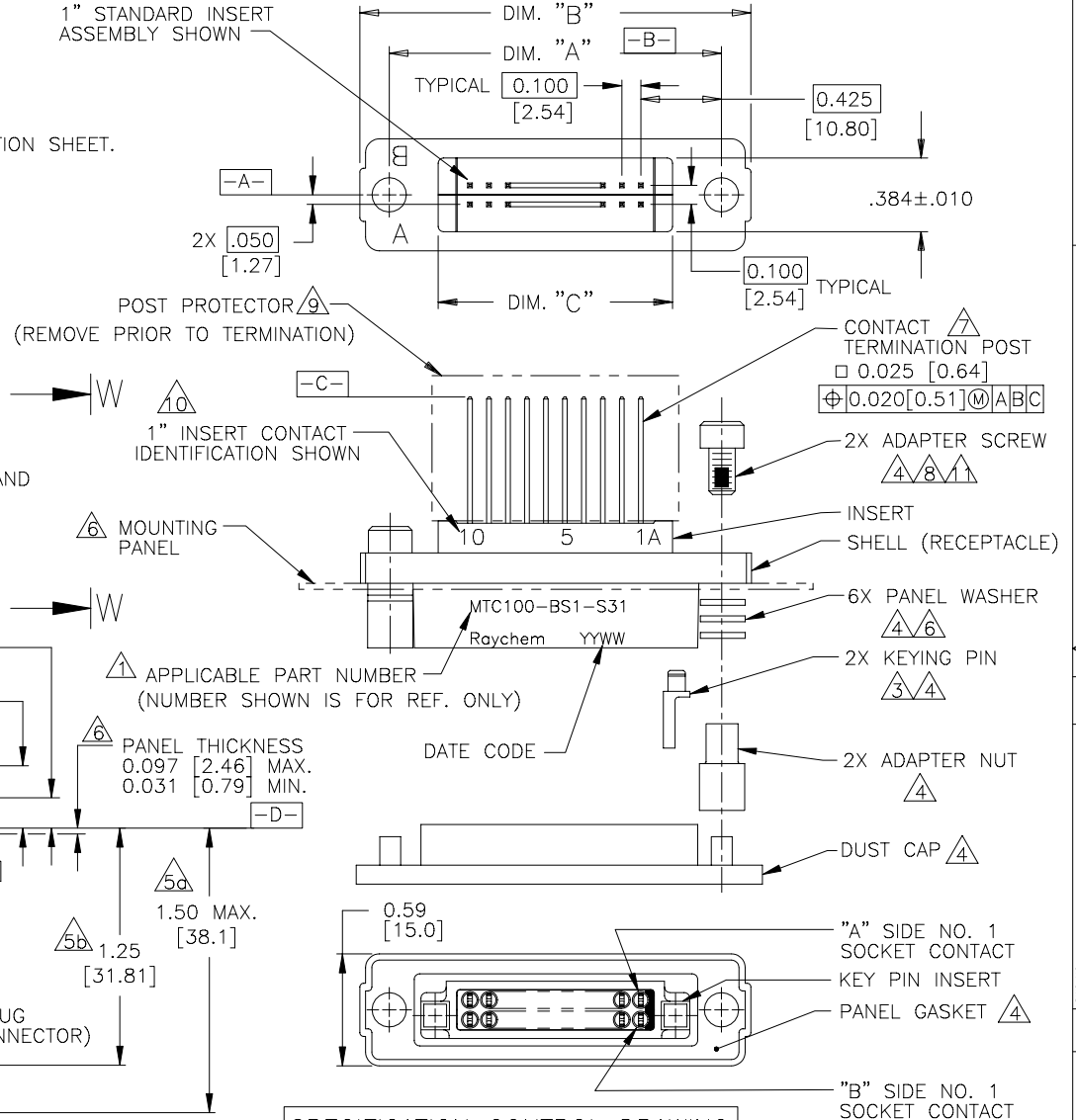

SPECIFICATION CONTROL DRAWING

THIS DRAWING AND THE INFORMATION SET FORTH HEREON ARE THE PROPERTY OF RAYCHEM CORPORATION. PUBLICATION, DUPLICATION, DISCLOSURE OR USE FOR ANY PURPOSE OTHER THAN THE CUSTOMER'S DIRECT NEEDS FOR THE APPLICATION CONCERNED, ARE PROHIBITED.

UNLESS OTHERWISE SPECIFIED DIMENSIONS ARE IN INCHES. METRIC DIMENSIONS ARE IN BRACKETS.

DECIMALS: .XXX ± .005 [0.13 mm], .XX ± .02 [0.51 mm]; ANGLES: .X ±; WEIGHT

Table with 2 columns: Field (RE-DRAWN, CHECKED, APPROVED, CAD NAME, THIRD ANGLE PROJECTION) and Value (J.VALENTA, M.HIGGY, T22751a.DWG).

Table with 4 columns: TITLE (CONNECTOR, RECEPTACLE, FLANGED, BOXMOUNT, SOCKET, .025 SQ. TERMINATION POST, MTC100 SERIES), SIZE (C), CODE IDENT. NO. (06090), DWG. NO. (MTC100-BXX-SXX-XXX), REV (H).

SHEET 1 OF 1 MTC100-BXX-SXX-XXX

4

3

2

1

FIGURE 1
BASIC DESIGN VARIATIONS

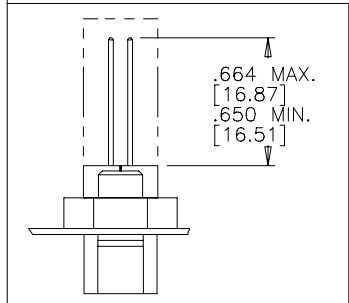

LONG TERMINATION POSTS
MTC100-BF/SX-SX1

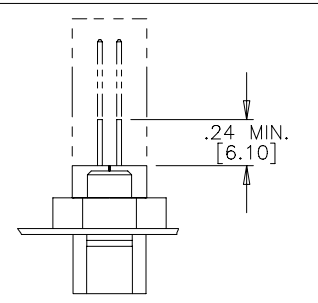

SHORT TERMINATION POSTS
MTC100-BF/SX-SX2

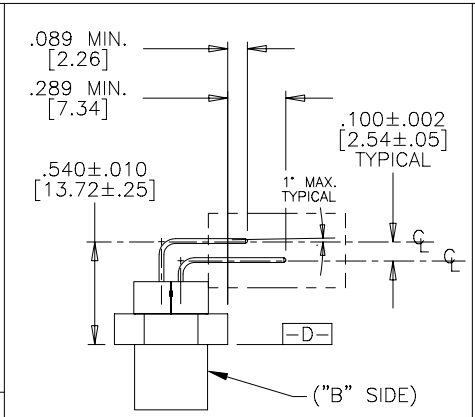

TERMINATION POSTS BENT
90° IN "B" DIRECTION
MTC100-BF/SX-SX3

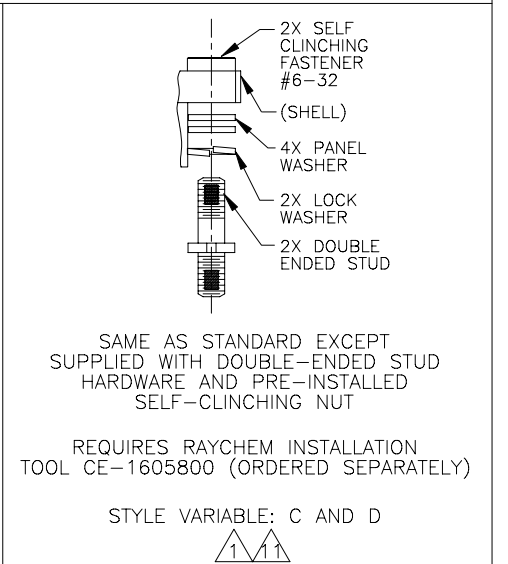
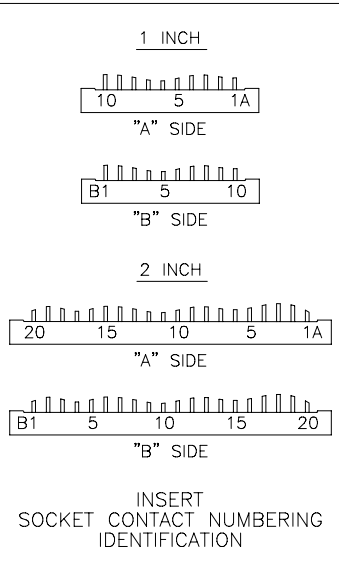

If this document is printed it becomes uncontrolled.
Check with the web for latest revision.

SIZE C	CODE IDENT. NO. 06090	DWG. NO. MTC100-BXX-SXX-XXX	REV H
DO NOT SCALE THIS DRAWING		DWG. NAME T22751b.DWG	SHEET 2 OF 3

4

3

2

1

SHEET 2
MTC100-BXX-SXX-XXX

SPECIFICATIONS:

MATERIALS:

- | | |
|--|--|
| A. SHELL | ALUMINUM ALLOY PER QQ-A-591 |
| B. ADAPTER SCREW | STAINLESS STEEL PER QQ-S-763, 300 SERIES |
| C. ADAPTER NUT | STAINLESS STEEL PER QQ-S-763, 300 SERIES |
| D. STANDARD PANEL GASKET
EME PANEL GASKET | SILICONE ELASTOMER PER MIL-R-25988
CONDUCTIVE FLOROSILICONE |
| E. INSERT | HIGH GRADE THERMOPLASTIC DIELECTRIC |
| F. KEYING PIN | HIGH GRADE THERMOPLASTIC DIELECTRIC |
| G. SOCKET CONTACT | COPPER ALLOY 172 PER QQ-C-533 |
| H. PANEL WASHER | STAINLESS STEEL PER QQ-S-763, 300 SERIES |
| J. KEYING PIN INSERT | HIGH GRADE THERMOPLASTIC DIELECTRIC |

FINISH:

	APPLIES TO NICKEL PLATED CONNECTORS (STANDARD PLATING)	APPLIES TO CADMIUM PLATED CONNECTORS
A. SHELL	NICKEL PLATED PER MIL-C-26074 CLASS 3, GRADE B	CADMIUM PLATED PER QQ-P-416 OVER NICKEL UNDERPLATE
B. ADAPTER SCREW	PASSIVATED PER QQ-P-35	CADMIUM PLATED PER QQ-P-416
C. ADAPTER NUT	PASSIVATED PER QQ-P-35	CADMIUM PLATED PER QQ-P-416
D. PANEL WASHER	PASSIVATED PER QQ-P-35	CADMIUM PLATED PER QQ-P-416
E. SOCKET CONTACT	ENGAGING END - GOLD PLATED PER MIL-G-45204 TYPE 1, GRADE C, CLASS 1	

DESIGN AND CONSTRUCTION:

THE CONNECTORS SPECIFIED HEREIN ARE PANEL MOUNTED RECEPTACLES WITH FIXED (NON-REMOVABLE) SOCKET INSERTS AND CONTACTS. THE CONNECTOR IS WITHOUT PROVISIONS FOR CABLE CLAMPS OR TERMINATION SEALS.

PERFORMANCE:

THE APPLICABLE RAYCHEM SPECIFICATION FOR THIS PART IS C6111. THIS PART IS NOT QUALIFIED TO C6111.

HUMIDITY
ALTITUDE IMMERSION
ALTITUDE - LOW TEMPERATURE
FLUID IMMERSION

THE CONNECTOR TERMINATION END MUST BE SUITABLY PROTECTED FOR TESTING OR APPLICATION IN ANY OF THESE ENVIRONMENTS.

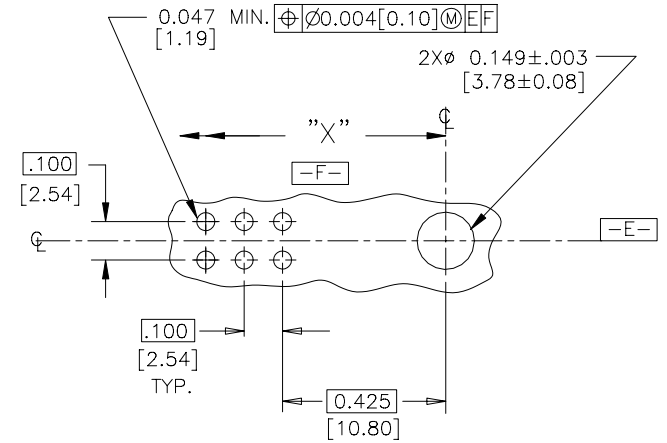

FIGURE 3
RECOMMENDED HOLE PATTERN AND SIZE FOR PRINTED CIRCUIT BOARDS

"Z" MINIMUM RECOMMENDED CENTERLINE FOR ADJACENT MOUNTING

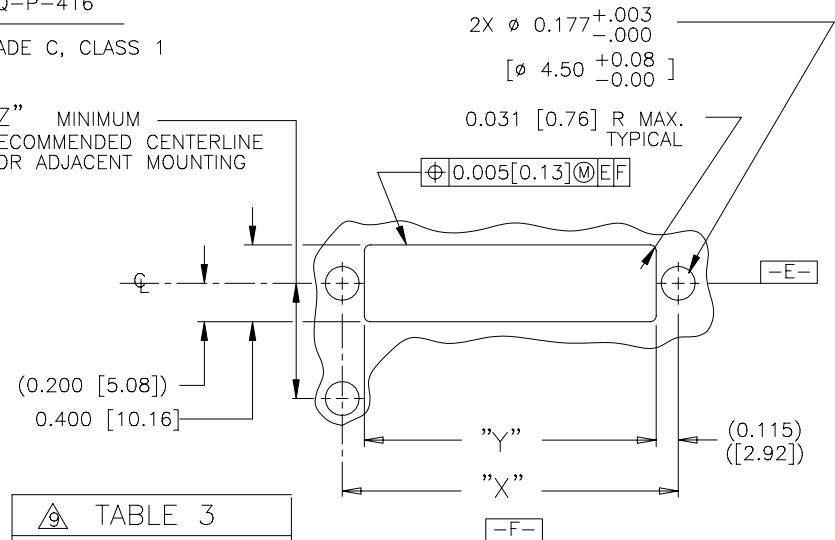

FIGURE 4
RECOMMENDED PANEL CUT-OUT

CONNECTOR SIZE	"A"	"B"	"C"	"X"	"Y"	"Z"
1 INCH	1.750 [44.45]	2.06 [52.3]	1.234 [31.34]	1.750 [44.45]	1.520 [38.61]	0.600 [15.24]
2 INCH	2.750 [69.85]	3.06 [77.7]	2.234 [56.74]	2.750 [69.85]	2.520 [64.00]	0.600 [15.24]

PANEL THICKNESS	NUMBER OF PANEL WASHERS FOR EACH FASTENER
0.031/0.036 [0.8]/[0.9]	2
0.062/0.067 [1.5]/[1.7]	1
0.93/0.097 [2.3]/[2.4]	0

WEIGHT lbs.[gr.] MAX.	
1 INCH CONNECTOR	.049 [22.33]
2 INCH CONNECTOR	.068 [30.82]

If this document is printed it becomes uncontrolled. Check with the web for latest revision.

SIZE C	CODE IDENT. NO. 06090	DWG. NO. MTC100-BXX-SXX-XXX	REV H
DO NOT SCALE THIS DRAWING		DWG. NAME T22751c.DWG	SHEET 3 OF 3

Компания «Life Electronics» занимается поставками электронных компонентов импортного и отечественного производства от производителей и со складов крупных дистрибьюторов Европы, Америки и Азии.

С конца 2013 года компания активно расширяет линейку поставок компонентов по направлению коаксиальный кабель, кварцевые генераторы и конденсаторы (керамические, пленочные, электролитические), за счёт заключения дистрибьюторских договоров

Мы предлагаем:

- Конкурентоспособные цены и скидки постоянным клиентам.
- Специальные условия для постоянных клиентов.
- Подбор аналогов.
- Поставку компонентов в любых объемах, удовлетворяющих вашим потребностям.
- Приемлемые сроки поставки, возможна ускоренная поставка.
- Доставку товара в любую точку России и стран СНГ.
- Комплексную поставку.
- Работу по проектам и поставку образцов.
- Формирование склада под заказчика.
- Сертификаты соответствия на поставляемую продукцию (по желанию клиента).
- Тестирование поставляемой продукции.
- Поставку компонентов, требующих военную и космическую приемку.
- Входной контроль качества.
- Наличие сертификата ISO.

В составе нашей компании организован Конструкторский отдел, призванный помогать разработчикам, и инженерам.

Конструкторский отдел помогает осуществить:

- Регистрацию проекта у производителя компонентов.
- Техническую поддержку проекта.
- Защиту от снятия компонента с производства.
- Оценку стоимости проекта по компонентам.
- Изготовление тестовой платы монтаж и пусконаладочные работы.



Тел: +7 (812) 336 43 04 (многоканальный)

Email: org@lifeelectronics.ru