

## Product Specification

### 10 GBPS 1310NM PIN + PREAMP LC ROSA PACKAGE

### PIN-1310-10LR-LC

#### PRODUCT FEATURES

- LC ROSA PIN-1310-10LR-LC includes flex circuit
- High performance InGaAs PIN photodiode with separate transimpedance amplifier
- Low electrical parasitic TO46 package
- Data rates up to 11.3Gbps
- Separate PD supply for power monitoring
- Low bias currents and voltages
- Low power dissipation
- IEEE 10G-BASE-LR applications

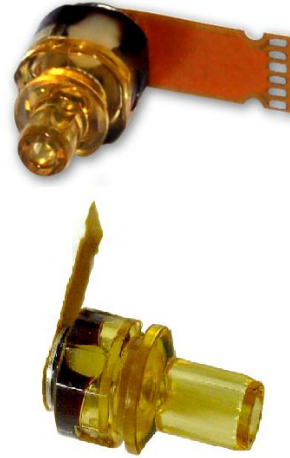

The PIN-1310-10LR-LC uses a high-performance InGaAs PIN photo-detector packaged with a transimpedance amplifier designed to meet performance requirements for data rates up to 11.3Gbps data communication over singlemode and multi-mode optical fiber at 1310nm. Applications include Ethernet, Fiber Channel and ATM protocols. The optical assembly is designed to interface to single mode optical fiber.

The PIN-1310-10LR-LC is designed to be paired with Finisar FP and DFB TOSA products (see data sheets for FP-1310 and DFB-1310 and products). The PIN is RoHS compliant per Directive 2011/65/EU<sup>1</sup>.

#### PRODUCT SELECTION

Part Number	Description
N-1310-10LR-LC	pin LC ROSA, with separate PD bias, with flex circuit

## I. Absolute Maximum Ratings

Parameter	Rating
Storage Temperature	-40 to +85°C
Case Operating Temperature	-10 to +85°C
Lead Solder Temperature	260°C, 10 sec.
Power Supply Voltage	-0.5V to 4V
Incident Optical Power	+3 dBm average, +5 dBm peak
Storage Temperature	-40 to +85°C

### Notice

Stresses greater than those listed under “Absolute Maximum Ratings” may cause permanent damage to the device. This is a stress rating only and functional operation of the device at these or any other conditions above those indicated in the operations section for extended periods of time may affect reliability.

### Notice

The inherent design of this component causes it to be sensitive to electrostatic discharge (ESD). To prevent ESD-induced damage and/or degradation to equipment, take normal ESD precautions when handling this product



## II. Electro-Optical Characteristics (3.0V<V<sub>cc</sub><3.6V, AC coupled to 50Ω (100Ω differential), -10°C<T<85°C unless otherwise specified, with flex)

Parameters	Test Condition	Symbol	Min.	Typ.	Max.	Units	Notes
Data Rate		DR	0.1		11.3	Gbps	
Supply Voltage			3.0	3.3	3.6	V	
Supply Current	P <sub>R</sub> = 0μW, R <sub>L</sub> = 50Ω AC coupled	I <sub>CC</sub>		35	60	mA	1
Optical Return Loss	P <sub>R</sub> = -12dBm	ORL	12			dB	1
Input Optical Wavelength		λ <sub>P</sub>	1260		1620	nm	
PD Responsivity	λ = 1310nm	Resp	0.8	0.85		A/W	1
PD Bias		V <sub>PD</sub>	3.0	3.3	3.6		
Maximum Average Input Power before Overload		P <sub>MAX</sub>	+1	+3		dBm	
Differential Output Voltage Swing	P <sub>R,OMA</sub> = -12Bm, AC Coupled to R <sub>L</sub> = 50Ω	V <sub>o(pk-pk)</sub>	100		600	mV	1,2
Differential Responsivity	P <sub>R,OMA</sub> = -12dBm, AC Coupled to R <sub>L</sub> = 50Ω	T	1500			V/W	1,2
-3dB Optical/Electrical Bandwidth	T <sub>A</sub> = 25°C	BW	7.5			GHz	1,2,3
Low Frequency -3dB Cutoff		BW <sub>LF</sub>			30	KHz	1,2,3
Output Impedance		Z <sub>OUT</sub>	40	50	60	Ω	
Output Return Loss	R <sub>0</sub> = 50Ω, DC 10 ≤ GHZ	S <sub>22</sub>			-7	dB	
Sensitivity	DR = 10.3125Gbps	S			-16.5	dBm	4
Stressed Sensitivity	Circadiant Test	S <sub>STRESS</sub>			-12	dBm	4
Rise/Fall Time	P <sub>R,OMA</sub> = -12dBm, (20%-80%),	T <sub>R</sub> /T <sub>F</sub>			45	ps	2,5
Differential Power Supply Rejection Ratio	P <sub>R</sub> = 0μW (Dark), 5MHz < F < 2GHz	PSRR	20			dB	1,6
Group Delay	P <sub>R,OMA</sub> = -12dBm, AC Coupled to R <sub>L</sub> = 50Ω 2MHz < F < 6GHz	Delay	-50		50	ps	7

### Notes:

1. P<sub>R</sub> is the average optical power at the fiber face.
2. P<sub>R,OMA</sub> is the peak to peak optical power at the fiber face (Optical Modulation Amplitude)

$$P_{R,OMA} \equiv \frac{2P_R(ER-1)}{ER+1} \text{ where ER is the extinction ratio (linear) of the optical source.}$$

3. Bandwidth and Low Frequency Cutoff are measured with a small signal sinusoidal light source with -10dBm average power
4. Sensitivity is measured with an optical source with an extinction ratio of 6dB. For sensitivity measurements at 10.3125, 10.51875, 10.70923, 11.09573, 11.31764 Gb/s, PRBS 2<sup>31</sup>-1, ER=6dB, BER < 10<sup>-12</sup> and with limiting of the TIA is assumed to be implemented at the front end of the post amplifier. Stress testing is done using a Circadiant test system
5. Rise/Fall times are corrected for optical source Rise/Fall times.  $T_{TIA}^2 = T_{MEASURED}^2 - T_{OPTICAL}^2$
6. Value shown is with no external power supply filtering.
7. Group delay is a sensitive measurement to package interface, and includes the effects of PD, TIA and package. Measurement is made with TO leads as short as possible.
8. DJ<sub>TIA</sub> is specified as contributed DJ by the TIA, obtained from  $DJ_{TIA}^2 = DJ_{TOTAL}^2 - DJ_{OPTICAL}^2$
9. RJ<sub>TIA</sub> is specified as contributed RJ by the TIA, obtained from  $RJ_{TIA}^2 = RJ_{TOTAL}^2 - RJ_{OPTICAL}^2$
10. The electrical performance of the ROSA is dependent upon the quality of the electrical connection between the TO can and the circuit board. AOC cannot guarantee all performance specifications for parts without the flex circuit attached.

### III. Environmental Specifications

Parameter	Symbol	Min	Typ	Max	Units	Ref.
Case Operating Temperature	T <sub>op</sub>	-10		85	°C	
Storage Temperature	T <sub>sto</sub>	-40		85	°C	

### IV. Mechanical Specifications

PIN	Description
1	V <sub>CC</sub>
2	CASE
3	OUTP
4	OUTN
5	CASE
6	V <sub>PD</sub>

(dimensions are in mm)

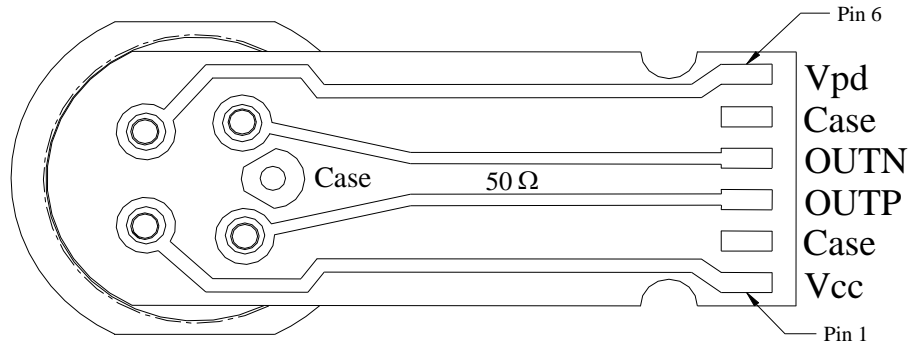

PIN-1310-10LR-XX

**INTERFACE EXAMPLE**

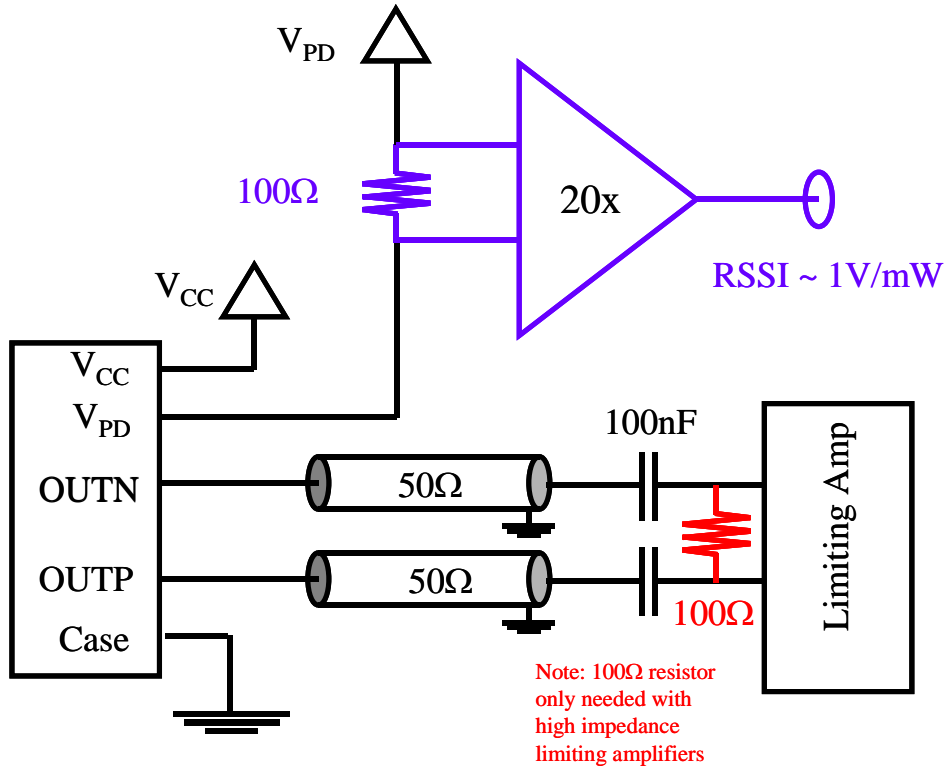

Optional 100Ω differential termination for high impedance limiting amplifiers is shown in red.

**Recommended bias network**

Note, better performance will be obtained if a ferrite bead is used in place of the inductor.

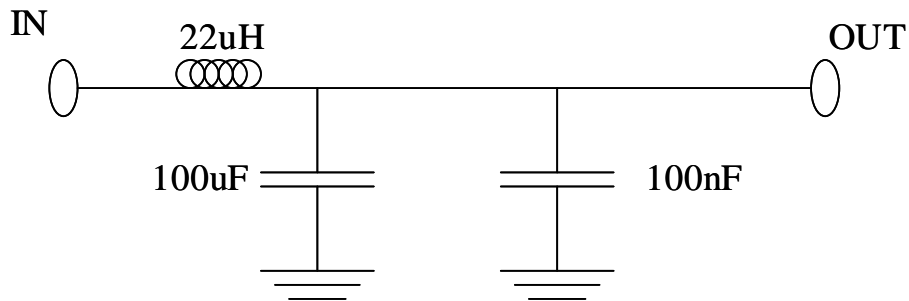

**Mounting Dimensions (in mm)**

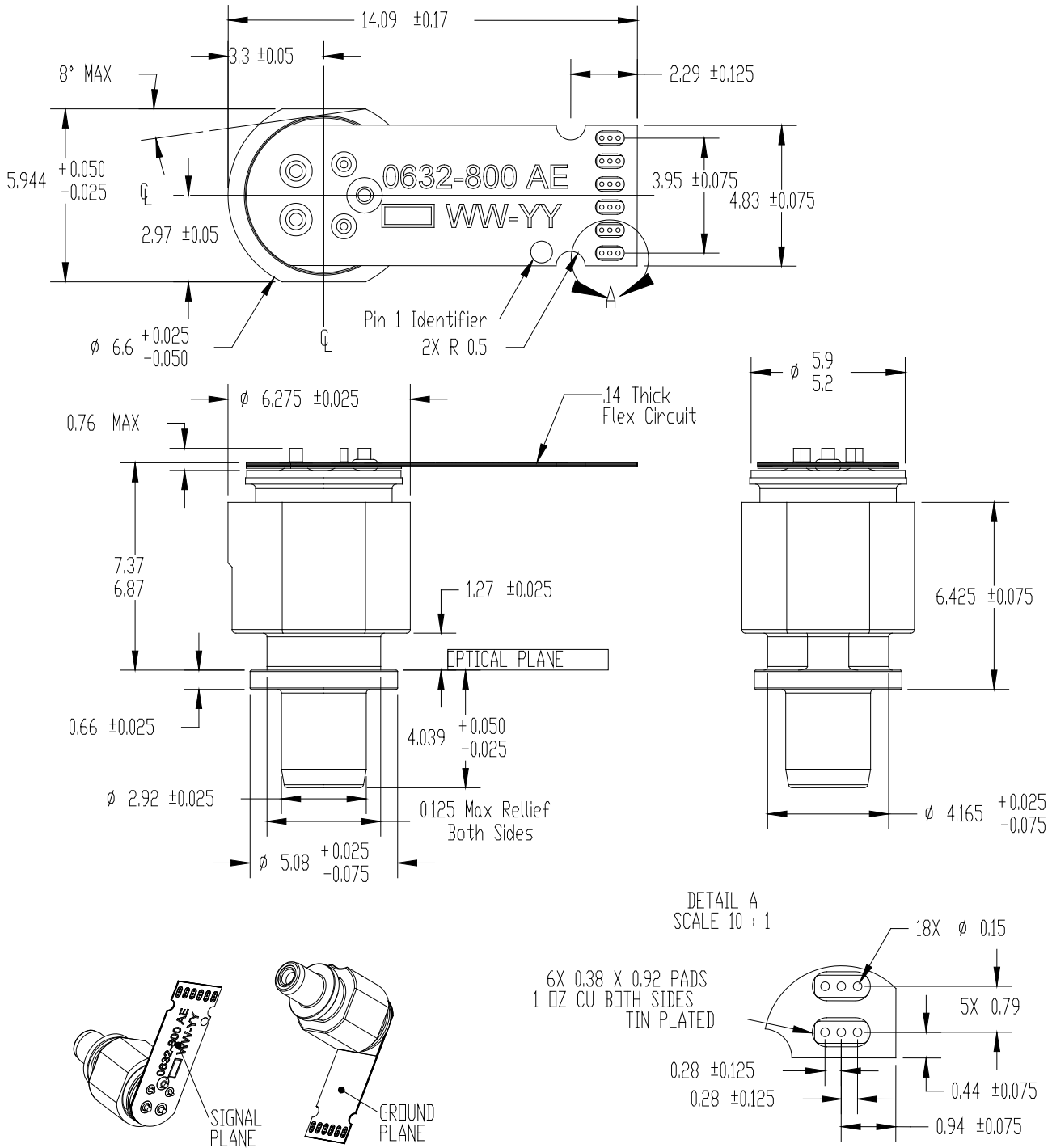

**V. References**

1. Directive 2011/65/EU of the European Parliament and of the Council, “on the restriction of the use of certain hazardous substances in electrical and electronic equipment”. Certain products may use one or more exemption as allowed by the Directive.

**VI. Revision History**

<b>Revision</b>	<b>Date</b>	<b>Description</b>
B00	10/14/2014	Converted to Finisar standard format.
C1	10/20/2015	Updated logo and RoHS statement.

**VII. For More Information**

Finisar Corporation  
1389 Moffett Park Drive  
Sunnyvale, CA 94089-1133  
Tel. 1-408-548-1000  
Fax 1-408-541-6138  
[sales@finisar.com](mailto:sales@finisar.com)  
[www.finisar.com](http://www.finisar.com)

Компания «Life Electronics» занимается поставками электронных компонентов импортного и отечественного производства от производителей и со складов крупных дистрибьюторов Европы, Америки и Азии.

С конца 2013 года компания активно расширяет линейку поставок компонентов по направлению коаксиальный кабель, кварцевые генераторы и конденсаторы (керамические, пленочные, электролитические), за счёт заключения дистрибьюторских договоров

Мы предлагаем:

- Конкурентоспособные цены и скидки постоянным клиентам.
- Специальные условия для постоянных клиентов.
- Подбор аналогов.
- Поставку компонентов в любых объемах, удовлетворяющих вашим потребностям.
- Приемлемые сроки поставки, возможна ускоренная поставка.
- Доставку товара в любую точку России и стран СНГ.
- Комплексную поставку.
- Работу по проектам и поставку образцов.
- Формирование склада под заказчика.
- Сертификаты соответствия на поставляемую продукцию (по желанию клиента).
- Тестирование поставляемой продукции.
- Поставку компонентов, требующих военную и космическую приемку.
- Входной контроль качества.
- Наличие сертификата ISO.

В составе нашей компании организован Конструкторский отдел, призванный помогать разработчикам, и инженерам.

Конструкторский отдел помогает осуществить:

- Регистрацию проекта у производителя компонентов.
- Техническую поддержку проекта.
- Защиту от снятия компонента с производства.
- Оценку стоимости проекта по компонентам.
- Изготовление тестовой платы монтаж и пусконаладочные работы.



Тел: +7 (812) 336 43 04 (многоканальный)

Email: [org@lifeelectronics.ru](mailto:org@lifeelectronics.ru)