

# nanoX-TCR

Extreme Rugged™ COM Express® Type 10 Mini-size  
Computer-on-Module with Intel® Atom™ Processor E6xxT



## Features

- Intel® Atom™ Processor E6xxT from 600 MHz up to 1.6 GHz
- COM Express® Mini form factor 84 x 55 mm
- 1-2 GB soldered industrial grade 800MHz DDR2 SDRAM
- 24-bit LVDS and SDVO support
- PCI Express x1 lanes
- Intel® Platform Controller Hub EG20T for USB, LAN, SDIO, Serial & CAN bus and SATA
- Optional Solid State Drive up to 16 GB
- COM Express® COM.0 R2.1 Type 10 Pinout
- Extended Temperature: -40°C to +85°C
- 50% Thicker PCB for high vibration environments

## Choose Ampro by ADLINK™ nanoX-TCR for...

A modular and power efficient solution for extreme rugged and mobile environments.

## Description

The Ampro by ADLINK™ nanoX-TCR is a COM Express® Nano Type 10 module with the Intel® Atom™ Processor E6xxT. The nanoX-TCR is designed Extreme Rugged for wide temperature range and high vibration environments.

## Specifications

### Core System

CPU	Intel® Atom™ E680T, 1.6 GHz, 3.9 W TDP Intel® Atom™ E660T, 1.3 GHz, 3.3W TDP Intel® Atom™ E620T, 600 MHz, 2.7W TDP All versions support -40°C to +85°C wide operating temperature range All processors support Intel® Hyper-Threading and Intel® Virtualization Technology
L2 cache	512 KB on all processors
Memory	Soldered 1GB DDR2 at 800MHz (Optional for 512MB or 2GB)
BIOS	License-free bootloader or AMI UEFI BIOS
Hardware Monitor	Supply voltages and CPU temperature
Debug Interface	XDP SFF-26 extension for ICE debug
Embedded Features	Instant on with Intel Bootloader support, Board Info & Statistics, ACPI 3.0, Smart Battery Management support, Watchdog with programmable timer ranges
Expansion Busses	2 PCI Express x1 available (0/1, port 2 used by GbE, port 3 used for EG20T PCH) LPC Bus, SMBus (system), I2C (user) 4 GPI and 4 GPO SPI (supports BIOS only)

### Video

2D/3D Graphic Engine	Integrated in Intel® Atom™ Processor E6xx
Decoding	MPEG2, MPEG4, VC1, WMV9, H.264 and DivX
Encoding	MPEG4, H.264 (baseline at L3)
LVDS Interface	Single channel 18- or 24-bit pixel color depths with maximum resolution of up to 1280x768 @ 60 Hz. Pixel clock rate between 19.75 MHz (minimum) and 80 MHz (maximum).
SDVO	Serial digital video output supporting devices for DVI, TV-out, analog VGA. Maximum resolution of up to 1280x1024 @ 85Hz and pixel clock rate up to 160 MHz.

### Audio

High Definition Audio Characteristics	Integrated in Intel® Atom™ Processor E6xx Multi-channel audio stream, 32-bit sample depth, sample rate up to 192 kHz
Audio Codec	On carrier (standard support for ALC888)

### Multi I/O and Storage

Chipset	Integrated in Intel® PCH EG20T
USB	Six USB 1.1/2.0 host ports and one USB 1.1/2.0 client port
SATA	Two ports supporting SATA 1.5 Gb/s and 3 Gb/s
Solid State Drive (optional)	4GB, 8GB or 16GB capacity. Occupies 1 SATA port when populated
Serial and CAN	Two RS-232 (optional one RS-232 (RX/TX) and one CAN (AX/RX) port) Bosch CAN Protocol Version 2.0B Active 1 (standard and extended format)

### LAN

Ethernet	Intel® 82574IT Gigabit Ethernet Controller
Speed	10/100/1000 Mbps

### Power Specifications

Input Power	4.75 V – 21 V wide range, supports AT mode and ATX mode (with additional 5 Vsb)
Power States	Supports S0, S1, S3, S4, S5
Power Consumption	5W at 5V typical, 3W idle
Smart Battery Support	Yes

### Mechanical and Environmental

Size	COM Express Mini, 84 mm x 55 mm (3.3" x 2.17")
Board Thickness	0.093" (2.3mm)
Operating Temp. Standard	-20°C to 70°C
Operating Temp. Extended	-40°C to 85°C
Storage Temp.	-55°C to 85°C
Humidity	90% at 60°C
Shock	50G peak-to-peak, 11ms duration, MIL-STD-202G Method 213B
Vibration	Operating: 11.96 Grms, 50-20,000 Hz, each axis, MIL-STD-202G Method 214A
Compatibility	PICMG COM Express COM.0 R2.1 Type 10
Certifications	CE, FCC, HALT

### Operating Systems

Standard Support	Windows XP / Windows 7 Linux®
Extended Support (BSP)	Windows XP Embedded WinCE 6.0 VxWorks 6.x QNX AIDI Library

## Functional Diagram

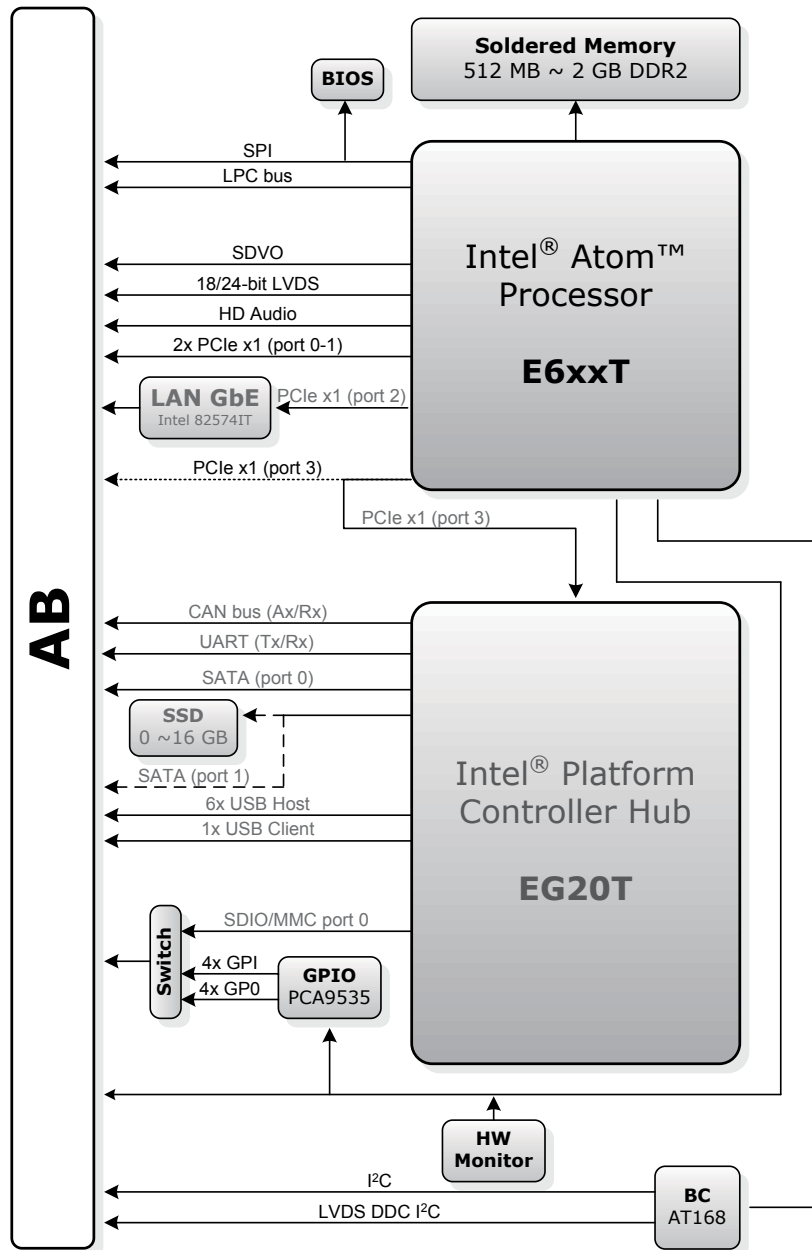

## Ordering Information

### Modules

Model Number	Description
nanoX-TCR-R-06	Extreme Rugged™ nanoX-TCR, Intel® Atom™ Processor E620T 0.6Ghz, 1GB DDR2 SDRAM
nanoX-TCR-R-13	Extreme Rugged™ nanoX-TCR, Intel® Atom™ Processor E660T 1.3Ghz, 1GB DDR2 SDRAM
nanoX-TCR-R-16	Extreme Rugged™ nanoX-TCR, Intel® Atom™ Processor E680T 1.6Ghz, 1GB DDR2 SDRAM, 4GB SSD
nanoX-TCR-L-06	QSK with R-06 module, THS-nXTCR-B passive heatsink, LCD panel, non-ETT, 250W power supply, cable kit, Software and reference manual
nanoX-TCR-L-13	QSK with R-13 module, THS-nXTCR-B passive heatsink, LCD panel, non-ETT, 250W power supply, cable kit, Software and reference manual
nanoX-TCR-L-16	QSK with R-16 module, THS-nXTCR-B passive heatsink, LCD panel, non-ETT, 250W power supply, cable kit, Software and reference manual

### Accessories

Model Number	Description
<b>Heat Spreaders</b>	
HTS-nXTCR-B	Heatspreader for nanoX-TCR with threaded hole standoffs for bottom mounting
HTS-nXTCR-BTF	Heatspreader for nanoX-TCR with through hole standoffs for top mounting
<b>Passive Heatsinks</b>	
THS-nXTCR-B	Heatsink nanoX-TCR with threaded hole standoffs for bottom mounting

Компания «Life Electronics» занимается поставками электронных компонентов импортного и отечественного производства от производителей и со складов крупных дистрибьюторов Европы, Америки и Азии.

С конца 2013 года компания активно расширяет линейку поставок компонентов по направлению коаксиальный кабель, кварцевые генераторы и конденсаторы (керамические, пленочные, электролитические), за счёт заключения дистрибьюторских договоров

Мы предлагаем:

- Конкурентоспособные цены и скидки постоянным клиентам.
- Специальные условия для постоянных клиентов.
- Подбор аналогов.
- Поставку компонентов в любых объемах, удовлетворяющих вашим потребностям.
- Приемлемые сроки поставки, возможна ускоренная поставка.
- Доставку товара в любую точку России и стран СНГ.
- Комплексную поставку.
- Работу по проектам и поставку образцов.
- Формирование склада под заказчика.
- Сертификаты соответствия на поставляемую продукцию (по желанию клиента).
- Тестирование поставляемой продукции.
- Поставку компонентов, требующих военную и космическую приемку.
- Входной контроль качества.
- Наличие сертификата ISO.

В составе нашей компании организован Конструкторский отдел, призванный помогать разработчикам, и инженерам.

Конструкторский отдел помогает осуществить:

- Регистрацию проекта у производителя компонентов.
- Техническую поддержку проекта.
- Защиту от снятия компонента с производства.
- Оценку стоимости проекта по компонентам.
- Изготовление тестовой платы монтаж и пусконаладочные работы.



Тел: +7 (812) 336 43 04 (многоканальный)

Email: [org@lifeelectronics.ru](mailto:org@lifeelectronics.ru)