

IB IL TEMP 4/8 RTD-EF-XC-PAC

**Inline Modular analog input terminal,
version for extreme conditions,
8 inputs, RTD**

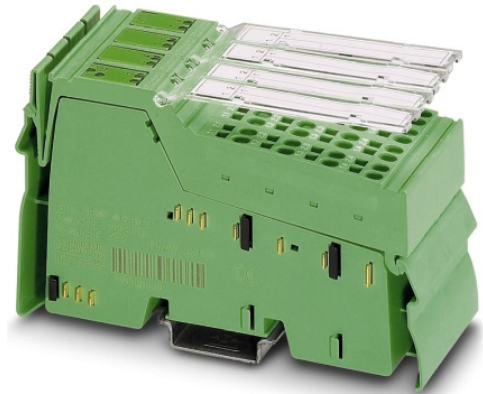

Data sheet
8466_en_01

© PHOENIX CONTACT 2012-05-08

1 Function description

The terminal is designed for use within an Inline station. This terminal provides an 8-channel input module with three linear resistance ranges for resistance temperature detectors.

This terminal supports, for example:

- Platinum and nickel sensors, e.g., Pt100, Pt1000, Ni100, and Ni1000 according to the DIN IEC 60751 standard and to the SAMA RC 21-4-1966 guideline
- KTY81 and KTY84 sensors
- Cu10, Cu50, and Cu53 sensors

Communication either via

- Parameter channel (PCP), all eight measuring channels, or
- Four process data words; always four channels (four 16-bit values) using the multiplex method

Thanks to special engineering measures and tests, the terminal can be used under extreme ambient conditions.

Features

- Connection of eight RTD temperature sensors and linear resistors in 4-wire technology
- High precision and noise immunity
- Temperature stability
- High-resolution temperature and resistance measurement
- Resistance values (R_0) can be preset separately using configuration bits
- Channels are configured independently of one another using the bus system.
- Configuration of open circuit detection sensitivity (firmware 1.10 or later)
- Additional representation in float format according to IEEE 754
- Diagnostic and status indicators
- Channel scout functionality, e.g., for optical channel identification during startup
- Can be used under extreme ambient conditions
- Painted PCBs
- Extended temperature range T2 (-40°C ... +55°C)



This data sheet is only valid in association with the IL SYS INST UM E user manual.



Make sure you always use the latest documentation.
It can be downloaded at www.phoenixcontact.net/catalog.

Table of contents

1 Function description 1

2 Ordering data..... 3

3 Technical data 4

4 Tolerance and temperature response 7

5 Tested successfully: Use under extreme ambient conditions 9

6 Internal basic circuit diagram10

7 Local diagnostic and status indicators and terminal point assignment.....11

8 Safety note.....11

9 Installation instructions11

10 Electrical isolation..... 12

11 Connection notes.....12

12 Connection examples12

13 Process data.....15

14 OUT process data words15

15 IN process data words19

16 Formats for representing measured values.....20

17 PCP communication22

18 Object descriptions22

19 Configuration and analog values.....27

20 Temperature and resistance measuring ranges.....27

21 Measuring errors due to connection cables27

22 Calculation examples29

23 Configuration example31

24 Notes on diagnostic behavior in the event of an error33

2 Ordering data

Products

Description	Type	Order No.	Pcs. / Pkt.
Inline Modular analog input terminal, version for extreme conditions, 8 inputs, RTD (resistance temperature detector), 4-wire connection method, complete with individually numbered I/O connectors	IB IL TEMP 4/8 RTD-EF-XC-PAC	2701218	1

Accessories: Connectors

Description	Type	Order No.	Pcs. / Pkt.
Inline connectors	IB IL SCN-8	2726337	10
Labeling field, 12.2 mm width	IB IL FIELD 2	2727501	5
Insert strip, sheet, white, unlabeled, can be labeled with: Office printing systems, plotter: laser printer, Mounting type: insertion, lettering field size: 62 x 10 mm	ESL 62X10	0809492	1

Accessories: Other

Description	Type	Order No.	Pcs. / Pkt.
Shield connection clamp for applying the shield on busbars			
8 mm diameter	SK8	3025163	10
14 mm diameter	SK14	3025176	10
20 mm diameter	SK20	3025189	10
35 mm diameter	SK35	3026463	10
Support for assembly on DIN rails for 10 mm x 3 mm busbars	AB-SK	3025341	10
Support for direct mounting with contact to the mounting surface	AB-SK 65	3026489	10
Support, made of insulation material, with fixing screws, can be used for either 10 mm x 3 mm or 6 mm x 6 mm busbars	AB-SK/E	3026476	10
N busbar, 10 mm x 3 mm, 1 m long	NLS-CU 3/10	0402174	10
End terminal, 4 mm ² , without insulating cap	AK 4	0404017	50
End terminal, 4 mm ² , with insulating cap, green-yellow for PE	AK G GNYE	0421029	50
End terminal, 4 mm ² , with insulating cap, black for L1, L2, L3	AKG 4 BK	0421032	50

Documentation

Description	Type	Order No.	Pcs. / Pkt.
"Automation terminals of the Inline product range" user manual	IL SYS INST UM E	-	-

3 Technical data

Dimensions (nominal sizes in mm)

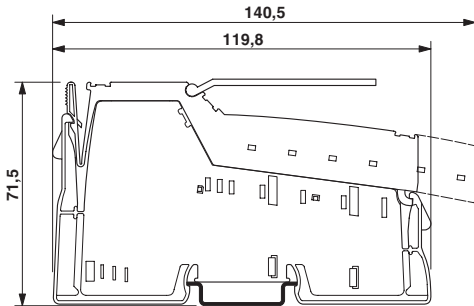

Housing dimensions (width x height x depth)	48.8 x 119.8 x 71.5 mm
---	------------------------

General data

Color	Green
Weight	190 g (with connectors)
Operating mode	Process data mode with 5 words/1 word PCP
Connection method for sensors	4-wire technology
Ambient temperature (operating)	-40 °C ... +60°C (see also the "Tested successfully: Use under extreme ambient conditions" section of the data sheet).
Permissible ambient temperature (storage/transport)	-40 °C ... +85°C
Temperature class	T2 (-40°C ... +55°C, IEC 50155)
Permissible humidity (operation/storage/transport)	10% ... 95%, according to DIN EN 61131-2
Permissible air pressure (operation/storage/transport)	70 kPa ... 106 kPa (up to 3000 m above sea level)
Degree of protection according to IEC 60529	IP20
Class of protection	III, IEC 61140, EN 61140, VDE 0140-1

Connection data

Designation	Inline connector
Connection method	Spring-cage connection
Conductor cross section, solid/stranded	0.08 mm ² ... 1.5 mm ²
Conductor cross section [AWG]	28 ... 16

Inline local bus interface

Connection method	Inline data jumper
Transmission speed	500 kbps

Supply of the module electronics and I/O through bus coupler/power terminal

Connection method	Potential routing
-------------------	-------------------

Power consumption

Communications power U_L	7.5 V
Current consumption from U_L	95 mA (typical)
I/O supply voltage U_{ANA}	24 V DC
Current consumption at U_{ANA}	6.0 mA (typical)
Total power consumption	0.85 W (typical)

Analog inputs

Number	Eight inputs (4-wire RTD) for resistive temperature detectors
Resolution of the analog/digital converter	24 bits
Measured value representation	16 bits (IL standard 15 bits + sign bit)
Standardized representation for	Degrees Celsius (°C), degrees Fahrenheit (°F) and as linear resistance in Ohms (Ω)
Resolution (quantization)	Standardized representation of temperature measurement values
In the °C range	0.1 K/LSB (default setting) 0.01K/LSB
In the °F range	0.1°F/LSB 0.01°F/LSB
In the linear Ohm range	0.01 Ω/LSB 0.1 Ω/LSB 1 Ω/LSB
Connection of signals	4-wire, shielded sensor cable (e.g., LiYCY (TP))
Maximum permissible cable length	250 m (4-wire connection with LiYCY (TP) 2 x 2 x 0.5 mm ²)
Crosstalk attenuation (channel/channel) in the sensor type operating mode:	
Pt100 (resolution 0.01 K/LSB)	98.6 dB, typical
R _{Lin} 500 (resolution 0.01Ω/LSB)	100 dB, typical
R _{Lin} 5000 (resolution 0.1Ω/LSB)	88 dB, typical
Sensor types that can be used	Pt, Ni, Cu, KTY, linear resistors
Standards for characteristic curves	According to DIN EN 60751: 07/1996/ according to SAMA RC 21-4-1966
Process data update	Depending on the filter time

Scan filter times

Set filter time	Typical scan time for each measuring channel	Typical scan repeat time for all eight measuring channels
480 ms (default)	482 ms	3300 ms
200 ms	201 ms	2190 ms
120 ms	121 ms	1874 ms
100 ms	100 ms	1800 ms

Differential non-linearity (typical)

In all ranges	1 ppm or ±0.0001%
---------------	-------------------

Integral non-linearity (typical)

In the input ranges	
Pt100	30 ppm or ±0.003%
R _{Lin} 500 Ω	20 ppm or ±0.002%
R _{Lin} 5000 Ω	200 ppm or ±0.02%

Supported measuring ranges

Sensor type	Standard or manufacturer specification	Measuring range	
		Lower limit	Upper limit
Pt sensors (e.g., Pt100, Pt500, Pt1000)	DIN IEC 60751 or SAMA RC 21-4-1966	-200°C	+850°C
Ni sensors (e.g., Ni100, Ni1000)	DIN IEC 60751 or SAMA RC 21-4-1966	-60°C	+180°C
Ni500 (Viessmann)	(Viessmann)	-60°C	+250°C
Ni1000 (Landis & Gyr)	(Landis & Gyr)	-50°C	+160°C
KTY81-110	(Philips)	-55°C	+150°C
KTY81-210	(Philips)	-55°C	+150°C
KTY84	(Philips)	-40°C	+300°C
Cu10	SAMA RC 21-4-1966	-70°C	+500°C

Supported measuring ranges (continued)

Sensor type	Standard or manufacturer specification	Measuring range	
		Lower limit	Upper limit
Cu50	SAMA RC 21-4-1966	-50°C	+200°C
Cu53	SAMA RC 21-4-1966	-50°C	+180°C
Linear resistor R_{Lin} 500 Ω (linear range 1)		0 Ω	525 Ω
Linear resistor R_{Lin} 5000 Ω (linear range 2)		0 Ω	5250 Ω
Linear resistor R_{Lin} 30000 Ω (linear range 3)		0 Ω	31500 Ω

Common mode rejection with different filter times

Filter process data encoding	Filter time	Optimization for common mode interference with $F_{Interfer}$	Typical common mode rejection for measuring inputs of analog/digital converters (CMRR)
00	480 ms	50 Hz and 60 Hz	74 dB
01	120 ms	50 Hz	80 dB
10	101 ms	60 Hz	90 dB
11	200 ms	50 Hz and 60 Hz	69 dB

Protective equipment

Transient protection

Measuring inputs	Yes
Sensor supply	Yes

Electrical isolation/isolation of the voltage areas

To provide electrical isolation between the logic level and the I/O area, it is necessary to supply the station bus coupler and the sensors connected to the analog input terminal described here from separate power supply units. Interconnection of the power supply units in the 24 V area is not permitted (see also IL SYS INST UM E user manual).

Common potentials

The 24 V main voltage, 24 V segment voltage, and GND have the same potential. FE is a separate potential area.

Separate potentials in the system consisting of bus coupler/power terminal and I/O terminal

- Test distance

5 V supply incoming remote bus/7.5 V supply (bus logic)	500 V AC, 50 Hz, 1 min
5 V supply outgoing remote bus/7.5 V supply (bus logic)	500 V AC, 50 Hz, 1 min
7.5 V supply (bus logic), 24 V supply U_{ANA} / I/O	500 V AC, 50 Hz, 1 min
7.5 V supply (bus logic), 24 V supply U_{ANA} / functional earth ground	500 V AC, 50 Hz, 1 min
I/O/functional earth ground	500 V AC, 50 Hz, 1 min

- Test voltage

Error messages to the higher-level control or computer system

Failure of the internal, electrically isolated I/O voltage supply	Yes, peripheral fault message
Failure of or insufficient communications power U_L	Yes, peripheral fault message

Error messages via process data

Peripheral fault/user error	Yes (see Section 16 „Formats for representing measured values“)
-----------------------------	--

Programming data

Local bus (INTERBUS)

ID code	DF_{hex} (223_{dec})
Length code	05_{hex}
Input address area	10 bytes
Output address area	10 bytes

Programming data

Parameter channel (PCP)	2 bytes
Register length (bus)	12 bytes



For the programming data/configuration data of other bus systems, please refer to the corresponding electronic device data sheet (e.g., GSD, EDS).

PROFIBUS telegram data

Required parameter data	31 bytes
Required configuration data	5 bytes

Approvals

For the latest approvals, please visit www.phoenixcontact.net/catalog.

4 Tolerance and temperature response



The percentage tolerance values refer to the respective positive measuring range final value. Unless stated otherwise, nominal operation (nominal voltage, preferred mounting position, default format, default filter setting, identical measuring range setting for channels) is used as the basis. The tolerance values refer to the operating temperature range specified in the tables. The operable range outside this range is not taken into consideration. Please also observe the values for temperature drift and the tolerances under influences of electromagnetic interference. The maximum tolerance values represent the worst case measurement inaccuracy. They contain the theoretical maximum possible tolerances in the corresponding measuring ranges as well as the theoretical maximum possible tolerances of the calibration and test equipment.

Tolerances (typical/maximum) at T_A = +25°C

Sensor type (4-wire connection)	Measuring range (nominal range)		Absolute tolerance		Relative tolerance (of measuring range final value)	
	Lower limit	Upper limit	Typical	Maximum	Typical	Maximum
Pt100	-200°C	+200 °C ¹⁾	± 0.05 K	± 0.19 K	± 0.03% ²⁾	± 0.10% ²⁾
Pt100	-200°C	+850°C	± 0.09 K	± 0.34 K	± 0.01%	± 0.04%
Pt1000	-200°C	+850°C	± 0.29 K	± 0.61 K	± 0.03%	± 0.07%
Ni100	-60°C	+180°C	± 0.04 K	± 0.10 K	± 0.02%	± 0.05%
Ni1000	-60°C	+180°C	± 0.09 K	± 0.39 K	± 0.05%	± 0.22%
Ni1000 (Landis & Gyr)	-50°C	+160°C	± 0.09 K	± 0.43 K	± 0.06%	± 0.27%
KTY81-110	-55°C	+150°C	± 0.08 K	± 0.34 K	± 0.06%	± 0.27%
KTY81-210	-55°C	+150°C	± 0.05 K	–	± 0.03%	–
Linear resistance R _{Lin} 500 Ω	0 Ω	500 Ω	± 0.12 Ω	± 2.05 Ω	± 0.02%	± 0.41%
Linear resistance R _{Lin} 5000 Ω	0 Ω	5000 Ω	± 1.50 Ω	± 10.2 Ω	± 0.03%	± 0.20%
Linear resistance R _{Lin} 30000 Ω	0 Ω	30000 Ω	No data	No data	± 3%	No data, since this range is not calibrated



The data contains the offset error, gain error, and linearity error in its respective setting (4-wire technology).

See separate table for additional temperature values and possible tolerances under EMI. All errors indicated as a percentage are related to the positive measuring range final value. The data is related to nominal operation (preferred mounting position, U_s = 24 V, etc.) using 4-wire operation for RTD inputs. The maximum tolerance values represent the worst case measurement inaccuracy. They contain the theoretically maximum possible tolerances in the corresponding measuring ranges. The maximum tolerances of calibration and test equipment, which are theoretically possible, have also been taken into consideration. This data is valid for at least 24 months.

¹⁾ Specified separately, since the measuring range of ± 200°C is used for many applications.

²⁾ In the more limited measuring range, the relative tolerance is also related to the measuring range final value of +200°C.

Temperature and drift response at $T_A = -25^\circ\text{C}$ to $+60^\circ\text{C}$			
Sensor type	Measuring range	Typical drift	Maximum drift
Based on $T_A = 25^\circ\text{C}$			
Pt100 sensor	-200°C ... +850°C	5 ppm/K	18 ppm/K
Pt1000 sensor	-200°C ... +850°C	20 ppm/K	65 ppm/K
Ni100 sensor	-60°C ... +180°C	5 ppm/K	20 ppm/K
Ni1000 sensor	-60°C ... +180°C	20 ppm/K	65 ppm/K
Range R_{Lin1}	0 Ω ... 500 Ω	8 ppm/K	20 ppm/K
Range R_{Lin2}	0 kΩ ... 5 kΩ	25 ppm/K	80 ppm/K

Absolute tolerance values for the ambient temperature range $T_A = -25^\circ\text{C}$ to $+60^\circ\text{C}$			
Sensor type	Measuring range	Typical tolerance	Maximum tolerance
Pt100 DIN and SAMA sensors	-200°C ... +200°C	$\pm 0.10^\circ\text{C}$	$\pm 0.37^\circ\text{C}$

EMI behavior				
Type of electromagnetic interference	Standard	Level	Additional tolerances of measuring range final value (MRFV)	Criterion
Electromagnetic fields	EN 61000-4-3 IEC61000-4-3	10 V/m	< 0.1%	A
Fast transients (burst)	EN 61000-4-4 IEC61000-4-4	1.1 kV	No additional tolerances	A
Conducted interference	EN 61000-4-6 IEC 61000-4-6	150 kHz ... 80 MHz, 10 V, 80% AM (1 kHz)	No additional tolerances	A
Conducted interference (with parameterized ODS = 3, see note)	EN 61000-4-6 IEC 61000-4-6	150 kHz ... 300 MHz, 30 V , 80% AM (1 kHz)	No additional tolerances	A



The values are valid for the default settings of the module (Pt100, resolution 0.1 K/LSB). Even under EMI indicated above is the accuracy class of 0.1 retained.



Additional low tolerances may occur due to the influence of high-frequency electromagnetic interference caused by wireless transmission systems in the near vicinity. The values specified refer to nominal operation in the event of direct interference to components without additional shielding such as a steel cabinet, etc.
The above mentioned tolerances can be reduced by providing further shielding measures for the I/O module (e.g., use of a shielded control box/control cabinet). Please refer to the recommended measures in the IL SYS INST UM E Inline system manual.



Activation of the "open circuit detection sensitivity" (ODS) function is possible with firmware version 1.10 or later. When activating this function, please observe the "Notes on diagnostic behavior in the event of an error" on page 33.

5 Tested successfully: Use under extreme ambient conditions

The terminal has been tested successfully over 250 temperature change cycles in accordance with IEC 61131-2 in the range from -40°C to +70°C.

The following conditions were observed:

- The Inline devices for all connecting cables were connected with a minimum conductor cross section of 0.5 mm²
- The Inline station was installed on a wall-mounted horizontal DIN rail
- Fans were used to ensure continuous movement of air in the control cabinet
- The Inline station was not exposed to vibration or shock
- The Inline station was operated with a maximum of 24.5 V (ensured by using regulated power supply units)

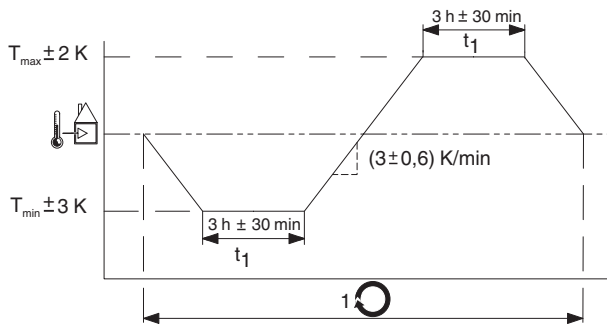

Figure 1 Temperature change cycle



Temperature in the control cabinet/ambient temperature



Cycle



WARNING:

The terminal is not approved for use in potentially explosive areas.

The terminal is not approved for use in safety technology.

6 Internal basic circuit diagram

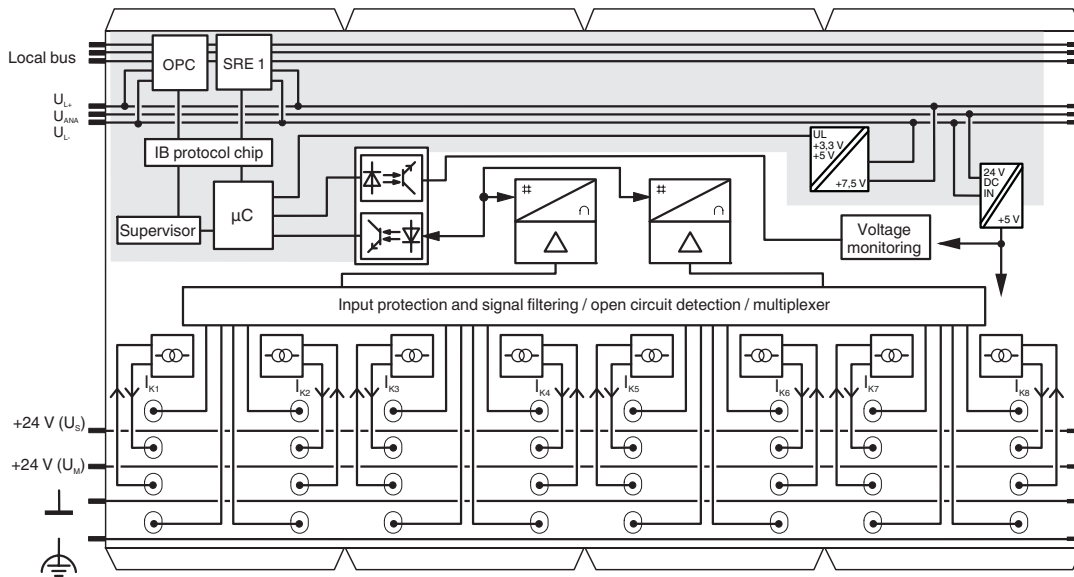

7567B002

Figure 2 Internal wiring of the terminal points

Key:



Protocol chip



Register expansion



Hardware monitoring



Hardware monitoring



Microcontroller



Optocoupler



Analog/digital converter



Amplifier



Voltage monitoring



DC/DC converter with electrical isolation

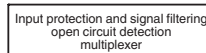

Input protection and signal filter, open circuit detection, multiplexer



Constant current source



Other symbols used are explained in the IL SYS INST UM E user manual.

7 Local diagnostic and status indicators and terminal point assignment

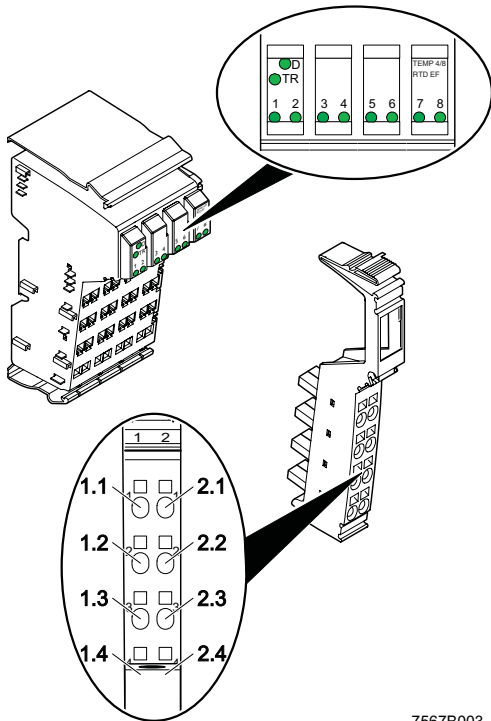

7567B003

Figure 3 terminal with an appropriate connector

7.1 Local diagnostics and status LEDs

Des.	Color	Meaning
D	Green	Diagnostics
TR	Green	PCP
LED 1 ... 8	Green ON	Measuring channel in operation
	Red ON	Open circuit, over-/underrange
	Orange	Channel Scout
	Flashing at 0.5 Hz	Channel "n" is selected for startup purposes with the PCP object (see Section "Channel Scout object (0090 _{hex})" on page 26).

7.2 Function identification

Green

2 Mbps: white stripe in the vicinity of the D LED

7.3 Terminal point assignment with 4-wire connection

Terminal points	Signal	Assignment
1.1	U_{1+}	RTD sensor 1
1.2	I_{1+}	
1.3	I_{1-}	Constant current supply
1.4	U_{1-}	
2.1	U_{2+}	RTD sensor 2
2.2	I_{2+}	
2.3	I_{2-}	Constant current supply
2.4	U_{2-}	

8 Safety note



WARNING: Electric shock

During configuration, ensure that no isolating voltage for safe isolation is specified between the analog inputs and the bus. During thermistor detection, for example, this means that the user has to provide signals with **safe isolation**, if applicable.

9 Installation instructions

High current flowing through potential jumpers U_M and U_S leads to a temperature rise in the potential jumpers and inside the terminal. To keep the current flowing through the potential jumpers of the analog terminals as low as possible, always place the analog terminals after all the other terminals at the end of the main circuit (for the sequence of the inline terminals: see also IL SYS INST UM E user manual).

10 Electrical isolation

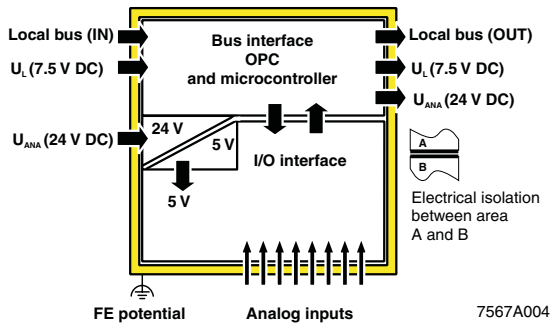

Figure 4 Electrical isolation of the individual function areas

11 Connection notes

Always connect temperature shunts using shielded, twisted-pair cables.

The connection examples show how to connect the shield (Figure 5).

Insulate the shield at the sensor.

Short-circuit unused channels (see Figure 5 on page 12, channel 4).

12 Connection examples



Connect the braided shield of the sensor cable at **one end only**.

For the assignments illustrated below, it is absolutely necessary to connect the cable shield at a central point in the control cabinet. The braided shield can be connected to a shield busbar using, for example, a shield connection clamp of SK8 type, Order No. 3025163.

12.1 4-wire connection

Slot	1	2	3	4
Channel	1 2	3 4	5 6	7 8

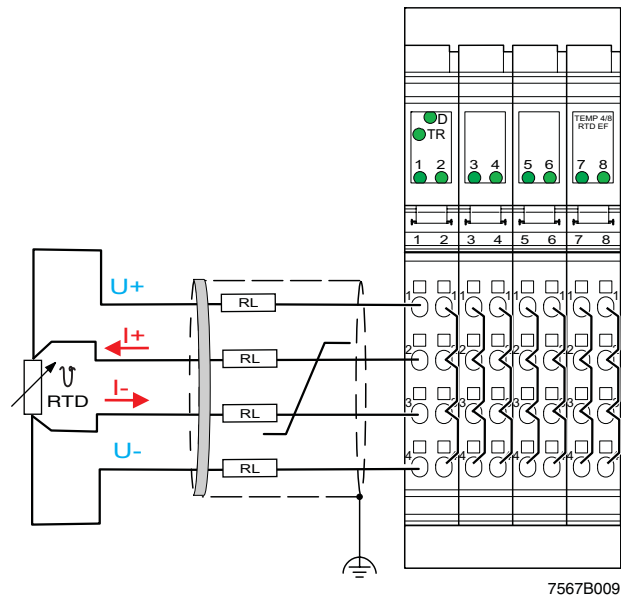

Figure 5 4-wire connection example

Example assignment:

Channel	Connection method	Remark
1	4-wire connection	
2 ... 8	Not used	Insert the short-circuit jumper.

12.2 3-wire connection



Manufacturer recommendation
 To improve the measured results of a 3-wire sensor on long sensor cables, Phoenix Contact recommends always combining 4-wire connection with the 3-wire sensor (see Figure 7 on page 13).

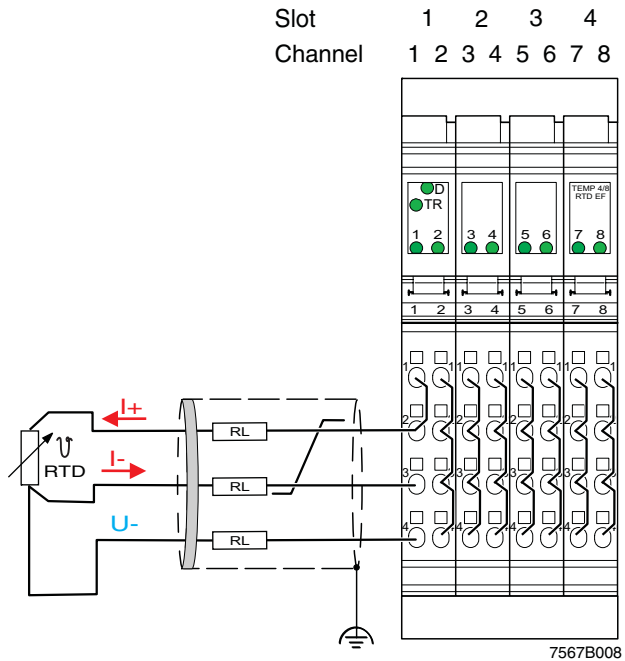

Figure 6 3-wire connection example

12.3 4-wire connection using a sensor in 3-wire technology

According to the assignment example illustrated below, RTD 3-wire sensors can also be used for long sensor cables with optimum accuracy using 4-wire connection of the terminal. This compensates for possible cable interferences, which may occur in conjunction with very long sensor cable lengths due to, for example, cable resistances, capacitances, and inductances. In addition, the temperature drift of the connection cable is eliminated.

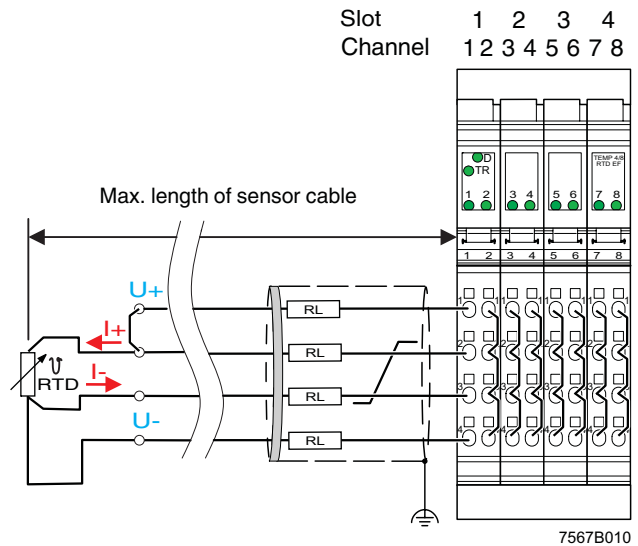

Figure 7 4-wire connection example using a sensor in 3-wire technology

12.4 2-wire connection

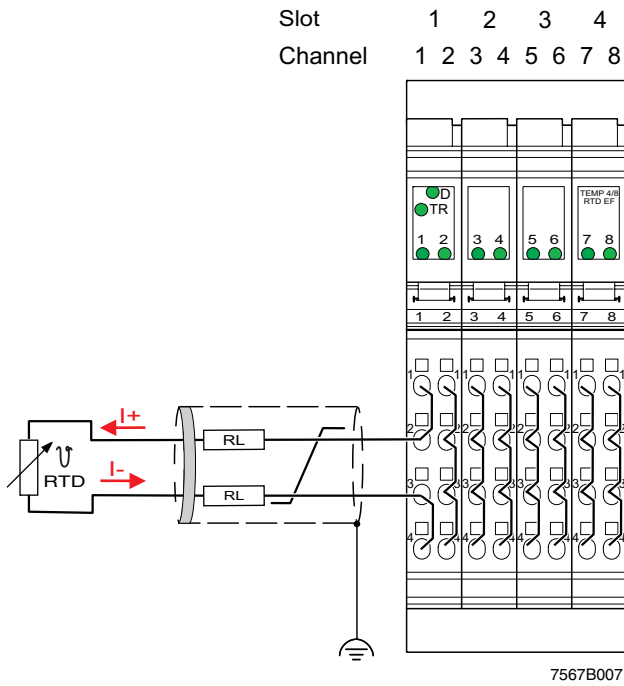

Figure 8 2-wire connection example

13 Process data

The module has five process data words. The first word is the control word, which is used to execute all actions. As confirmation for an action, the first input word contains a partial copy of the control word. The error bit indicates whether a command was carried out without errors. For the command codes 4x, 5x, and 60, a set error bit indicates an invalid configuration. For the commands used to read the measured values (command codes 00 ... 09), the error bit represents a group error message. If the error bit is set, there will be an error message on one or more channels.

The terminal has five process data words and one PCP word.

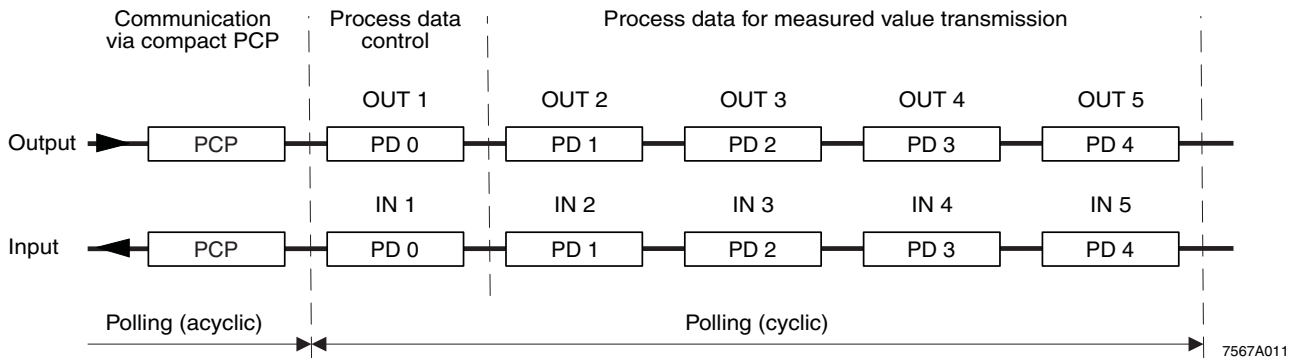

Figure 9 Order of the PCP word and the process data words

14 OUT process data words

Five process data output words are available.

Configure the terminal channels via the OUT process data words OUT1 and OUT2. In this context, the output word OUT1 contains the command and the output word OUT2 contains the parameters belonging to this command.

Configuration errors are indicated in the status word. The configuration settings are stored in a volatile memory.

If you change the configuration, the message "Measured value invalid" appears (diagnostics code 8004_{hex}), until new measured values are available.



Please note that extended diagnostics is only possible if the IB IL format is configured as the format for representing the measured values. As this format is preset on the terminal, it is available as soon as the voltage is applied.

14.1 Output word OUT1 (control word)

		OUT1															
Bit	Assignment	15	14	13	12	11	10	9	8	7	6	5	4	3	2	1	0
		Command code								0	0	ODS		0	0	0	0

Bit 15 to bit 8 (command code):

Bit								OUT1	Command function
15	14	13	12	11	10	9	8		
0	0	0	0	0	C	C	C	0x00 _{hex}	Read measured value in IN2 channel-by-channel.
0	0	0	0	1	0	0	0	0800 _{hex}	Read measured values of channel 1 to 4 into IN2 to IN5.
0	0	0	0	1	0	0	1	0900 _{hex}	Read measured values of channel 5 to 8 into IN2 to IN5.
0	0	0	1	0	C	C	C	1x00 _{hex}	Read configuration in IN2 channel-by-channel.
0	0	1	1	1	1	0	0	3C00 _{hex}	Read device data The firmware version and the device ID number are represented in IN2 (see Section 15.2 „Input words IN2 to IN5“).
0	1	0	0	0	C	C	C	4x00 _{hex}	Configure channel, configuration in OUT2
0	1	0	1	0	C	C	C	5x00 _{hex}	Configure channel and read measured value of the channel, configuration in OUT2, measured value in IN2.
0	1	1	0	0	0	0	0	6000 _{hex}	Configure entire terminal (all channels); configuration in OUT2

CCC = channel number

Channel assignment:

Bit			Channel number
10	9	8	
0	0	0	1
0	0	1	2
0	1	0	3
0	1	1	4
1	0	0	5
1	0	1	6
1	1	0	7
1	1	1	8

Bits 5 and 4 (ODS: open circuit detection sensitivity;
firmware version 1.10 or later)

Bit		ODS: open circuit detection sensitivity
5	4	
0	0	High sensitivity
0	1	Medium sensitivity
1	0	Reserved
1	1	Switched off



Please also observe the “Notes on diagnostic behavior in the event of an error” on page 33.

14.2 Output word OUT2 (parameter word)

The parameters for the commands 4x00_{hex}, 5x00_{hex}, and 6000_{hex} must be specified in OUT2. This parameter word is only evaluated for these commands.

		OUT2															
Bit		15	14	13	12	11	10	9	8	7	6	5	4	3	2	1	0
Assignment		0	Filter time			0	R ₀			Resolution		Format		Sensor type			

- R₀ Selection of sensor resistance at 0°C.
Here, for example, you can select whether Pt100, Pt500, or Pt1000 are to be used for the platinum sensor type.
- Resolution Quantization of the measured value, choice between °Celsius or °Fahrenheit
- Format Represents the measured value in the IN process data
- Sensor type Sets the selected sensor type



If invalid parameters are specified in the parameter word, the command will not be executed. The command is confirmed in the input words with the set error bit.

14.3 Parameters for configuration

The module can be configured either via process data or PCP. The error code "Measured value invalid" is output during configuration. If the configuration is invalid, the error bit is set in the status word. The configuration is only stored in a volatile memory. The first output word must contain the command, the second output word must contain the configuration value.

		OUT2															
Bit		15	14	13	12	11	10	9	8	7	6	5	4	3	2	1	0
Assignment		0	Filter time			0	R ₀			Resolution		Format		Sensor type			

Default settings are marked in **bold**.

Bits 14 and 13:

Code	Filter time
00	480 ms
01	120 ms
10	101 ms
11	200 ms

Bits 11 to 8:

Code		R ₀ [Ω]
Dec	Bin	
0	0000	100
1	0001	10
2	0010	20
3	0011	30
4	0100	50
5	0101	120
6	0110	150
7	0111	200

Code		R ₀ [Ω]
Dec	Bin	
8	1000	240
9	1001	300
10	1010	400
11	1011	500
12	1100	1000
13	1101	1500
14	1110	2000
15	1111	10000

Bits 7 and 6:

Code		Resolution for sensor type			
Dec	Bin	All temperature sensors	Linear R 0 ... 500 Ω	Linear R 0 ... 5 kΩ	Linear R 0 ... 30 kΩ
0	00	0.1°C	0.1 Ω	1 Ω	1 Ω
1	01	0.01°C	0.01 Ω	0.1 Ω	Res.
2	10	0.1°F	Reserved		
3	11	0.01°F			

Bits 5 and 4:

Code		Format
Dec	Bin	
0	00	IB IL format (15 bits + sign bit with extended diagnostics)
1	01	Reserved
2	10	S7-compatible format (15 bits + sign bit)
3	11	Reserved

Bits 3 to 0:

Code		Sensor type
Dec	Bin	
0	0000	Pt DIN
1	0001	Pt SAMA
2	0010	Ni DIN
3	0011	Ni SAMA
4	0100	Cu10
5	0101	Cu50
6	0110	Cu53
7	0111	Ni1000 (Landis & Gyr)
8	1000	Ni500 (Viessmann)
9	1001	KTY 81-110
10	1010	KTY 84
11	1011	KTY 81-210
12	1100	Linear R 0 ... 30 k Ω
13	1101	Reserved
14	1110	Linear R 0 ... 500 Ω
15	1111	Linear R 0 ... 5 k Ω

15 IN process data words

15.1 Input word IN1 (status word)

The input word IN1 serves as status word.

		IN1															
Bit		15	14	13	12	11	10	9	8	7	6	5	4	3	2	1	0
Assignment	EB	Mirrored command code								0	0	0	0	0	0	0	0

EB: Error bit

EB = 0 No error has occurred.

EB = 1 An error has occurred.

Mirroring of the command code:

A command code mirrored from the control word. Here, the MSB is suppressed.

15.2 Input words IN2 to IN5

The measured values, the configuration or the firmware version are transmitted to the controller board or the PC using the process data input words IN2 to IN5 in accordance with the configuration.

For the control word **3C00_{hex}**, IN2 supplies the firmware version and the module ID.

Example: firmware version 1.23:

		IN2															
Bit		15	14	13	12	11	10	9	8	7	6	5	4	3	2	1	0
Assignment (hex)		1				2				3				E _{hex}			
Meaning		Firmware version 1.23												Module ID			

Basically two formats are available for the representation of the measured values. For more detailed information about the formats, please refer to "Formats for representing measured values" on page 20.

		MSB															LSB
		15	14	13	12	11	10	9	8	7	6	5	4	3	2	1	0
SB		Analog value															IB IL format, S7-compatible format

MSB Most significant bit

LSB Least significant bit

SB Sign bit

AV Analog value

16 Formats for representing measured values

16.1 IB IL format (default setting)

The measured value is represented in bits 14 to 0. An additional bit (bit 15) is available as a sign bit. This format supports extended diagnostics. Values $> 8000_{\text{hex}}$ and $< 8100_{\text{hex}}$ indicate an error.

Measured value representation in IB IL format, 15 bits

MSB	LSB														
15	14	13	12	11	10	9	8	7	6	5	4	3	2	1	0
SB	Analog value														

SB Sign bit

IB input word		All temperature sensors [°C/°F]		R ₀ up to 500 Ω		R ₀ up to 5 kΩ	
Code (hex)	Dec	Resolution	Resolution	Resolution		Resolution	
		0.1°C/°F	0.01°C/°F	0.1 Ω	0.01 Ω	1 Ω	0.1 Ω
8001	Overrange	> Limit value	> Limit value	>525	>325.12	>5250	>3251.2
0FA0	1000	+100.0	+10.0	100.0	10.0	1000.0	100.0
0001	1	+0.1	+0.01	+0.1	+0.01	+1.0	+0.1
0000	0	0	0	≤ 0	≤ 0	≤ 0	≤ 0
FFFF	-1	-0.1	-0.01	-	-	-	-
FC18	-1000	-100.0	-10.0	-	-	-	-
8080	Underrange	< Limit value	< Limit value	-	-	-	-

The following diagnostics codes are supported:

Code (hex)	Error
8001	Overrange
8002	Open circuit
8004	Measured value invalid/no valid measured value available (e.g., because channel was not configured)
8010	Invalid configuration
8020	I/O supply voltage fault
8040	Terminal faulty
8080	Underrange



If the measured value is outside the representation area of the process data, the “Overrange” or “Underrange” error message is displayed.

16.2 S7-compatible format

The measured value for temperature and resistance values is represented in bits 14 to 0. An additional bit (bit 15) is available as a sign bit.

Measured value representation in S7 format, 15 bits

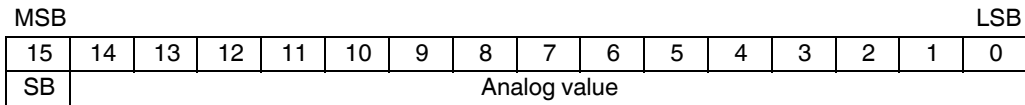

SB Sign bit

IB input word		All temperature sensors [°C/°F]		0 to 500 Ω		0 to 5 kΩ	
Code (hex)	Dec	Resolution	Resolution	Resolution		Resolution	
		0.1°C/°F	0.01°C/°F	0.1 Ω	0.01 Ω	1 Ω	0.1 Ω
7FFF	Overrange	> Limit value	> Limit value	>525	>325.12	>5250	>3251.2
0FA0	1000	+100.0	+10.0	100.0	10.0	1000.0	100.0
0001	1	+0.1	+0.01	+0.1	+0.01	+1.0	+0.1
0000	0	0	0	≤ 0	≤ 0	≤ 0	≤ 0
FFFF	-1	-0.1	-0.01	-	-	-	-
FC18	-1000	-100.0	-10.0	-	-	-	-
8000	Underrange	< Limit value	< Limit value	-	-	-	-

The following diagnostics codes are possible:

Code (hex)	Error
7FFF	Overrange
8002	Open circuit
8004	Measured value invalid/no valid measured value available (e.g., because channel was not configured)
8010	Invalid configuration
8020	I/O supply voltage fault
8040	Terminal defective
8000	Underrange

i	If the measured value is outside the representation area of the process data, the “Overrange” or “Underrange” error message is displayed.
----------	---

18.2 Config Table object (0080_{hex})

Configure the terminal using this object.

Object description:

Object	Config table		
Access	Read, Write		
Data type	Array of Unsigned 16	12 x 2 bytes	
Index	0080 _{hex}		
Subindex	00 _{hex} 01 _{hex} 02 _{hex} 03 _{hex} 04 _{hex} 05 _{hex} 06 _{hex} 07 _{hex} 08 _{hex} 09 _{hex} 0A _{hex} 0B _{hex} 0C _{hex}	Write all elements Configuration of channel 1 Configuration of channel 2 Configuration of channel 3 Configuration of channel 4 Configuration of channel 5 Configuration of channel 6 Configuration of channel 7 Configuration of channel 8 Reserved ODS (open circuit detection sensitivity) Reserved Reserved	
Length (bytes)	18 _{hex} 02 _{hex}	Subindex 00 _{hex} Subindex 01 _{hex} to 0C _{hex}	
Data	Terminal configuration		

Value range:

ODS (firmware 1.10 or later)

Bit	15	14	13	12	11	10	9	8	7	6	5	4	3	2	1	0
Assignment	0	0	0	0	0	0	0	0	0	0	ODS		0	0	0	0

Bits 5 and 4 (ODS: open circuit detection sensitivity)

Bit	ODS: open circuit detection sensitivity
5 4	
0 0	High sensitivity
0 1	Medium sensitivity
1 0	Reserved
1 1	Switched off

18.3 Analog Values object (0081_{hex})

The elements of this object contain the analog values of the channels in a format that has been selected for this channel.

Object description:

Object	Analog Values	
Access	Read	
Data type	Array of Unsigned 16	8 x 2 bytes
Index	0081 _{hex}	
Subindex	00 _{hex} 01 _{hex} 02 _{hex} 03 _{hex} 04 _{hex} 05 _{hex} 06 _{hex} 07 _{hex} 08 _{hex}	Read all elements Analog value of channel 1 Analog value of channel 2 Analog value of channel 3 Analog value of channel 4 Analog value of channel 5 Analog value of channel 6 Analog value of channel 7 Analog value of channel 8
Length (bytes)	10 _{hex} 02 _{hex}	Subindex 00 _{hex} Subindex 01 _{hex} to 08 _{hex}
Data	Analog values of the channels	

18.4 Measured Value Float object (0082_{hex})



This format provides the highest internal module accuracy and is independent of the configured resolution.

Object description:

Object	Measured Value Float		
Access	Read		
Data type	Array of Record	8 x 6 bytes	
Index	0082 _{hex}		
Subindex	01 _{hex} 02 _{hex} 03 _{hex} 04 _{hex} 05 _{hex} 06 _{hex} 07 _{hex} 08 _{hex}	Analog value of channel 1 Analog value of channel 2 Analog value of channel 3 Analog value of channel 4 Analog value of channel 5 Analog value of channel 6 Analog value of channel 7 Analog value of channel 8	
Length (bytes)	30 _{hex} 06 _{hex}	Subindex 00 _{hex} Subindex 01 _{hex} to 08 _{hex}	
Data	Analog values of the channels		

The extended float format is a specific format from Phoenix Contact and consists of the measured value, the status and the unit code. The status is required as there are no patterns informing about the status of the value defined in the float format. The status corresponds to the lower bytes of the Inline error code. For example, if status = 01 with overrange, the Inline error code is 8001_{hex}. The measured value is valid if status=0.

Measured value record:

Element	Data type	Length in bytes	Meaning
.1	Float	4	Measured value in float format according to IEEE 754
.2	Unsigned 8	1	Status
.3	Unsigned 8	1	Unit code: 32: °C, 33: °F, 37: Ω

Structure of the float format according to IEEE 754

Bit	25		17		9		1	
Assignment	VEEE	EEEE	EMMM	MMMM	MMMM	MMMM	MMMM	MMMM

S = 1 sign bit, 0: positive, 1: negative

E = 8 bits, exponent with offset 7F_{hex}

M = 23 bits, mantissa

Example values for the float format

1.0	3F 80 00 00 _{hex}
-1.0	BF 80 00 00 _{hex}
10	41 20 00 00 _{hex}
1.03965528	3F 85 13 6D _{hex}

18.5 Channel Scout object (0090_{hex})

The channel scout function supports the fast discovery of a measuring channel on the Inline terminal (e.g., during startup).



The channel scout functionality is superior to all diagnostics messages of the selected LED and must be disabled separately by the user. In comparison, the configuration of a channel automatically causes this functionality to be aborted.

Object description:

Object	Channel Scout		
Access	Read/ Write		
Data type	Unsigned		1 byte
Index	0090 _{hex}		
Length (bytes)	01 _{hex}	Subindex 00 _{hex}	
Data	Control of the channel LED		

Value range:

- 0 Disable all channel scout processes
- 1 ... 8 Orange LED of the channel is flashing at
0.5 Hz (1 second ON, 1 second OFF)

19 Configuration and analog values

The terminal only needs to be configured if the channels are not to be operated with the default values (see "Parameters for configuration" on page 17).

You can **either** configure the terminal via process data or via PCP and transmit analog values accordingly.

If you have configured the terminal via PCP, the configuration can no longer be modified via the process data.

Examples for terminal configuration via process data



For easy terminal configuration a function block can be downloaded at www.phoenixcontact.net/catalog.

20 Temperature and resistance measuring ranges

20.1 Measuring ranges depending on the resolution (IB IL format)

Resolution	Temperature sensors
00	-273°C to +3276.8°C; Resolution: 0.1°C
01	-273°C to +327.68°C; Resolution: 0.01°C
10	-459°F to +3276.8°F Resolution: 0.1°F
11	-459°F to +327.68°F Resolution: 0.01°F



Temperature values can be converted from °C to °F with this formula:

$$T [^{\circ}\text{F}] = T [^{\circ}\text{C}] \times \frac{9}{5} + 32$$

Where:

T [°F] Temperature in °F
T [°C] Temperature in °C

21 Measuring errors due to connection cables

21.1 4-wire technology

The terminal provides 4-wire technology for all eight channels and supports the maximum connection length of 250 meters for each sensor. Additional measuring tolerances caused by the cable length do not occur.

21.2 Systematic errors during temperature measurement using 2-wire technology

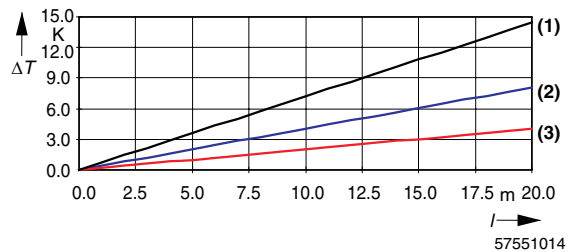

Figure 10 Systematic temperature measuring error ΔT depending on the cable length l

Curves depending on cable cross section A

- (1) Temperature measuring error for $A = 0.14 \text{ mm}^2$
- (2) Temperature measuring error for $A = 0.25 \text{ mm}^2$
- (3) Temperature measuring error for $A = 0.50 \text{ mm}^2$

(Measuring error valid for: copper cable $\chi = 57 \text{ m}/\Omega\text{mm}^2$, $T_A = 25^{\circ}\text{C}$ and Pt 100 sensor)

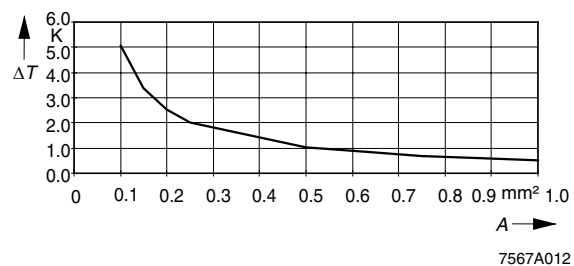

Figure 11 Systematic temperature measuring error ΔT depending on the cable cross section A

(Measuring error valid for: copper cable $\chi = 57 \text{ m}/\Omega\text{mm}^2$, $T_A = 25^{\circ}\text{C}$, $l = 5 \text{ m}$, and Pt100 sensor)

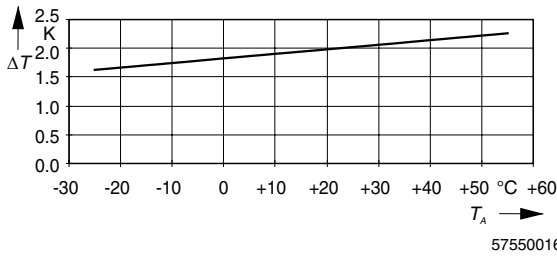

Figure 12 Systematic temperature measuring error ΔT depending on the cable temperature T_A

(Measuring error valid for: copper cable $\chi = 57 \text{ m}/\Omega\text{mm}^2$, $l = 5 \text{ m}$, $A = 0.25 \text{ mm}^2$, and Pt100 sensor)

All diagrams show that the increase in cable resistance causes the measuring error.

A considerable improvement is made through the use of Pt1000 sensors. Due to the 10 times higher temperature coefficient α ($\alpha = 0.385 \text{ } \Omega/\text{K}$ for Pt100 to $\alpha = 3.85 \text{ } \Omega/\text{K}$ for Pt1000) the effect of the cable resistance on the measurement is decreased by a factor of 10. All errors in the diagrams above would be reduced by factor 10.

Figure 9 clearly shows the effect of the cable length on the cable resistance and therefore on the measuring error. The solution is to use the shortest possible sensor cables.

Figure 10 shows the influence of the cable cross-section on the cable resistance. It can be seen that cables with a cross section of less than 0.5 mm^2 cause errors to increase exponentially.

Figure 11 shows the influence of the ambient temperature on the cable resistance. This parameter is of minor importance and can hardly be influenced. It is mentioned here only for the sake of completeness.

The formula for calculating the cable resistance is as follows:

$$R_L = R_{L20} \times \left(1 + 0.0039 \frac{1}{K} \times (T_A - 20^\circ\text{C}) \right)$$

$$R_L = \frac{l}{\chi \times A} \times \left(1 + 0.0039 \frac{1}{K} \times (T_A - 20^\circ\text{C}) \right)$$

Where:

R_L	Cable resistance in Ω
R_{L20}	Cable resistance at 20°C in Ω
l	Cable length in m
χ	Specific electrical resistance of copper in $\text{m}/\Omega\text{mm}^2$
A	Cable cross section in mm^2
$0.0039 \text{ } 1/\text{K}$	Temperature coefficient for copper (degree of purity of 99.9%)
T_A	Ambient temperature (cable temperature) in $^\circ\text{C}$

Since there are two cable resistances in the measuring system (forward and return), the value must be doubled. The absolute measuring error in Kelvin [K] is provided for platinum sensors according to DIN using the average temperature coefficient α ($\alpha = 0.385 \text{ } \Omega/\text{K}$ for Pt100; $\alpha = 3.85 \text{ } \Omega/\text{K}$ for Pt1000).

22 Calculation examples

22.1 Typical temperature behavior

Task:

Temperatures of up to +45°C are achieved in the control cabinet.

1. What typical drift values of the measuring inputs are to be expected for temperature measurement with a Pt100 sensor using 4-wire technology at a measuring temperature of +180°C for this terminal?
2. What typical measuring tolerance is to be expected at +45°C?

Calculation of typical drift values:

The temperature difference is calculated using the formula (1):

$$\Delta T_A = T_S - 25^\circ\text{C} \quad (1)$$

Where:

ΔT_A Temperature difference (difference between current switch cabinet temperature and reference temperature of +25°C)

T_S Current temperature in the switch cabinet

Value for this example:

$$T_S = 45^\circ\text{C}$$

According to formula (1)

$$\begin{aligned} \Delta T_A &= T_S - 25^\circ\text{C} \\ &= 45^\circ\text{C} - 25^\circ\text{C} \\ &= 20 \text{ K} \end{aligned}$$

The temperature drift of the Pt100 sensor is calculated according to formula (2):

$$T_{\text{Drift}} = \Delta T_A \times T_K \times T_M \quad (2)$$

Where:

T_{Drift} Temperature drift of the Pt100 sensor

ΔT_A Temperature difference; from formula (1)

T_K Temperature coefficient; see "Temperature and drift response at $T_A = -25^\circ\text{C}$ to $+60^\circ\text{C}$ " on page 8

T_M Measuring temperature

Values for this example:

$$\Delta T_A = 20 \text{ K}$$

$$T_K = \pm 5 \text{ ppm/K (typical drift)}$$

$$T_M = 180^\circ\text{C}$$

According to formula (2)

$$\begin{aligned} T_{\text{Drift}} &= \Delta T_A \times T_K \times T_M \\ &= 20 \text{ K} \times \pm 5 \text{ ppm/K} \times 180^\circ\text{C} \\ &= 20 \times \pm 5 \times 10^{-6} \times 180^\circ\text{C} \\ &= \pm 0.018 \text{ K} \\ T_{\text{Drift}} &= \pm 0.02 \text{ K} \end{aligned}$$

Solution:

Under these marginal conditions, a typical temperature drift of 0.02 K is to be expected.

Calculation of the typical measuring tolerance:

The measuring tolerance is calculated using the formula (3):

$$\Delta T_{\text{tot}} = \Delta T_{25} + T_{\text{Drift}} \quad (3)$$

Where:

ΔT_{tot} Total tolerance

ΔT_{25} Tolerance at 25°C; see "Tolerances (typical/maximum) at $T_A = +25^\circ\text{C}$ " on page 7

T_{Drift} Drift at 45°C; from formula (2)

Values for this example:

$$\Delta T_{25} = \pm 0.05 \text{ K}$$

$$T_{\text{Drift}} = \pm 0.02 \text{ K}$$

According to formula (3)

$$\begin{aligned} \Delta T_{\text{tot}} &= \Delta T_{25} + T_{\text{Drift}} \\ &= \pm 0.05 \text{ K} + \pm 0.02 \text{ K} \\ &= \pm 0.07 \text{ K} \end{aligned}$$

Solution:

With an ambient temperature of +45°C, a typical measuring tolerance of ±0.07 K is to be expected.

22.2 Maximum temperature behavior (worst case)

Task:

Temperatures of up to +40°C are achieved in the control cabinet.

What typical drift values of the measuring inputs are to be expected for temperature measurement with a Pt100 sensor using 4-wire technology at a measuring temperature of +200°C for this terminal?

Calculation:

The measuring tolerance is calculated using the formula (3):

$$\Delta T_{\text{tot}} = \Delta T_{25} + T_{\text{Drift}} \quad (3)$$

Values for this example:

$$\begin{aligned} \Delta T_{25} &= \pm 0.19 \text{ K} \\ T_{\text{Drift}} &\text{ Must be calculated} \end{aligned}$$

To calculate the drift, proceed as described in the example for the typical temperature response.

The temperature difference is calculated using the formula (1):

$$\Delta T_A = T_S - 25^\circ\text{C} \quad (1)$$

Value for this example:

$$T_S = 40^\circ\text{C}$$

According to formula (1)

$$\begin{aligned} \Delta T_A &= T_S - 25^\circ\text{C} \\ &= 40^\circ\text{C} - 25^\circ\text{C} \\ &= 15 \text{ K} \end{aligned}$$

The maximum temperature drift of the Pt100 sensor is calculated according to formula (2):

$$T_{\text{Drift}} = \Delta T_A \times T_K \times T_M \quad (2)$$

Values for this example:

$$\begin{aligned} \Delta T_A &= 15 \text{ K} \\ T_K &= \pm 18 \text{ ppm/K (maximum drift)} \\ T_M &= 200^\circ\text{C} \end{aligned}$$

According to formula (2)

$$\begin{aligned} T_{\text{Drift max.}} &= \Delta T_A \times T_K \times T_M \\ &= 15 \text{ K} \times \pm 18 \text{ ppm/K} \times 200^\circ\text{C} \\ &= 15 \times \pm 18 \times 10^{-6} \times 200^\circ\text{C} \\ &= \pm 0.054 \text{ K} \\ T_{\text{Drift max.}} &= \pm 0.05 \text{ K} \end{aligned}$$

The measuring tolerance is calculated using formula (3):

$$\Delta T_{\text{tot}} = \Delta T_{25} + T_{\text{Drift}} \quad (3)$$

Values for this example:

$$\begin{aligned} \Delta T_{25} &= \pm 0.19 \text{ K} \\ T_{\text{Drift}} &= \pm 0.05 \text{ K} \end{aligned}$$

According to formula (3)

$$\begin{aligned} \Delta T_{\text{tot}} &= \Delta T_{25} + T_{\text{Drift}} \\ &= \pm 0.19 \text{ K} + \pm 0.05 \text{ K} \\ &= \pm 0.24 \text{ K} \end{aligned}$$

Solution:

With an ambient temperature of +40°C, a **maximum worst case** measuring tolerance of 0.24 K is to be expected.

23 Configuration example

All eight channels of the terminal are preset to a Pt100 sensor and a filter time of 480 ms. In order to change default settings, the new configuration data should be transferred to the terminal.

Please refer to the following examples for the configuration procedure.

Channel no.	Sensor type	Filter time	Resolution	Configuration
1	Pt100 DIN	480 ms	0.1°C	0000 _{hex}
2	Ni100 DIN	480 ms	0.1°C	0002 _{hex}
3	Lin 500 Ω	480 ms	0.01Ω	004E _{hex}
4	Cu10	480 ms	0.1°C	0004 _{hex}
5	Pt100 DIN	480 ms	0.01°C	0040 _{hex}
6	Pt1000 DIN	480 ms	0.1°C	0C00 _{hex}
7	Ni500 DIN	480 ms	0.1°C	0B02 _{hex}
8	Lin 500 kΩ	480 ms	1.0 Ω	000F _{hex}

Step No.	Process data	Configuration
1	Out1 = 0000 _{hex} , 0800 _{hex} or 0900 _{hex}	Specify a passive command first
2	Wait until In1 = Out1	Wait for confirmation
3	Out2 = 0000 _{hex} Out1 = 4000 _{hex}	Configuration for channel 1
4	Wait until In1 = Out1	Wait for confirmation
5	Out2 = 0002 _{hex} Out1 = 4100 _{hex}	Configuration for channel 2
6	Wait until In1 = Out1	Wait for confirmation
7	Out2 = 004E _{hex} Out1 = 4200 _{hex}	Configuration for channel 3
8	Wait until In1 = Out1	Wait for confirmation
9	Out2 = 0004 _{hex} Out1 = 4300 _{hex}	Configuration for channel 4
10	Wait until In1 = Out1	Wait for confirmation
11	Out2 = 0040 _{hex} Out1 = 4400 _{hex}	Configuration for channel 5
12	Wait until In1 = Out1	Wait for confirmation
13	Out2 = 0C00 _{hex} Out1 = 4500 _{hex}	Configuration for channel 6
14	Wait until In1 = Out1	Wait for confirmation
15	Out2 = 0B02 _{hex} Out1 = 4600 _{hex}	Configuration for channel 7
16	Wait until In1 = Out1	Wait for confirmation
17	Out2 = 000F _{hex} Out1 = 4700 _{hex}	Configuration for channel 8
18	Wait until In1 = Out1	Wait for confirmation
19	Wait 4 seconds	Wait until all channels have settled
20	Out1 = 0800 _{hex}	Request measured values of channels 1 - 4
21	Wait until In1 = Out1	Wait for confirmation

Step No.	Process data	Configuration
22	Measured value channel 1 = In2 Measured value channel 2 = In3 Measured value channel 3 = In4 Measured value channel 4 = In5	Read measured values of channels 1 - 4
23	Out1 = 0900 _{hex}	Request measured values of channels 5 - 8
24	Wait until In1 = Out1	Wait for confirmation
25	Measured value channel 5 = In2 Measured value channel 6 = In3 Measured value channel 7 = In4 Measured value channel 8 = In5	Read measured values of channels 5 - 8

24 Notes on diagnostic behavior in the event of an error



The diagnostic system detects and reports single interrupted sensor wires or multiple interrupted sensor wires as well as completely disconnected sensor cables, see 24.1 to 24.4.

24.1 Diagnostic behavior in the event of an error with ODS = 0 or ODS = 1

The following error states are detected and indicated by the terminal itself. The errors are partly represented via the process input data and/or the corresponding diagnostic LEDs on the terminal.

Malfunction/error	Indication in the process data or other messages	Diagnostic and status indication
U_L (7.5 V) is missing	None, bus error	No LED is on.
Measured value is above the valid measuring range (e.g., 500 Ω at Pt100 input).	8001 _{hex} , overrange Error bit set in the first process data input word.	The LED of the relevant channel (1 ... 8) is red.
Sensor connector is not plugged in and/or the sensor cable is completely interrupted.	8002 _{hex} , open circuit Error bit set in the first process data input word.	The LED of the relevant channel (1 ... 8) is red.
Measured value invalid (e.g., during the reconfiguration of a channel)	8004 _{hex} , measured value invalid Error bit set in the first process data input word.	The LED of the relevant channel (1 ... 8) is temporarily red.
U_{ANA} (+24 V) is missing or failure of internal I/O voltages.	I/O error message is triggered.	The D LED is green and flashes at 2 Hz.
Internal component faulty	8040 _{hex} , self diagnostics Component error and error bit set in the first process data input word.	
Measured value is below the valid measuring range (e.g., 5 Ω at Pt100 input).	8080 _{hex} , underrange Error bit set in the first process data input word.	The LED of the relevant channel (1 ... 8) is temporarily red.

24.2 Diagnostic behavior in the event of an error with ODS = 3

For applications with particularly high EMC requirements (significantly higher than the standardized limit values) the ODS function can be set to value 3. This deactivates the open circuit detection function and allows for error-free measurements even under particularly high EMI.

Malfunction/error	Indication in the process data or other messages	Diagnostic and status indication
Sensor connector is not plugged in and/or the sensor cable is completely interrupted.	8001 _{hex} , overrange Error bit set in the first process data input word.	The LED of the relevant channel (1 ... 8) is red.

24.3 Diagnostics response times in the event of an open circuit

The following table lists the typical diagnostics response times if the sensor connector is not plugged in and/or the sensor cable is completely interrupted.

Settings for ODS (open circuit detection sensitivity)	Settings recommended for	Diagnostic message in the process data	Typical response time of all eight channels
0 _{hex} / High sensitivity	Interference coupling within the standardized level	8002 _{hex} (open circuit)	2 s ... 5 s
1 _{hex} / Medium sensitivity	Interference coupling slightly above the standardized level	8002 _{hex} (open circuit)	6 s
3 _{hex} / Disabled	Interference coupling significantly higher than the standardized level	8001 _{hex} (overrange)	15 s ... 17 s



The typical response time of the diagnostic messages was determined between the error event and the message in the process data. The time also includes transmission of the data to the control system/controller board in the test system used.

24.4 Diagnostics response times if single sensor wires are interrupted

The following table lists the typical diagnostics response times if single sensor wires are interrupted.

Settings for ODS (open circuit detection sensitivity)	Settings recommended for	Diagnostic message in the process data	Typical response time of all eight channels
0 _{hex} / High sensitivity	Interference coupling within the standardized level	8002 _{hex} (open circuit) or 8080 _{hex} (underrange)	2 s ... 5 s
1 _{hex} / Medium sensitivity	Interference coupling slightly above the standardized level	8002 _{hex} (open circuit) or 8080 _{hex} (underrange)	2 s ... 5 s
3 _{hex} / Disabled (see note below the table)	Interference coupling significantly higher than the standardized level	8001 _{hex} (overrange) or 8080 _{hex} (underrange)	2 s ... 60 s



CAUTION:

In the event of an ODS = 3 configuration:
Please note that the response time of the diagnostic message can be up to 60 seconds longer in your application when a single wire is broken.
During this time the measured values are either rising or falling.

Компания «Life Electronics» занимается поставками электронных компонентов импортного и отечественного производства от производителей и со складов крупных дистрибьюторов Европы, Америки и Азии.

С конца 2013 года компания активно расширяет линейку поставок компонентов по направлению коаксиальный кабель, кварцевые генераторы и конденсаторы (керамические, пленочные, электролитические), за счёт заключения дистрибьюторских договоров

Мы предлагаем:

- Конкуренспособные цены и скидки постоянным клиентам.
- Специальные условия для постоянных клиентов.
- Подбор аналогов.
- Поставку компонентов в любых объемах, удовлетворяющих вашим потребностям.
- Приемлемые сроки поставки, возможна ускоренная поставка.
- Доставку товара в любую точку России и стран СНГ.
- Комплексную поставку.
- Работу по проектам и поставку образцов.
- Формирование склада под заказчика.
- Сертификаты соответствия на поставляемую продукцию (по желанию клиента).
- Тестирование поставляемой продукции.
- Поставку компонентов, требующих военную и космическую приемку.
- Входной контроль качества.
- Наличие сертификата ISO.

В составе нашей компании организован Конструкторский отдел, призванный помогать разработчикам, и инженерам.

Конструкторский отдел помогает осуществить:

- Регистрацию проекта у производителя компонентов.
- Техническую поддержку проекта.
- Защиту от снятия компонента с производства.
- Оценку стоимости проекта по компонентам.
- Изготовление тестовой платы монтаж и пусконаладочные работы.



Тел: +7 (812) 336 43 04 (многоканальный)

Email: org@lifeelectronics.ru