



MAX4208 Evaluation Kit

General Description

The MAX4208 evaluation kit (EV kit) simplifies evaluation of the MAX4208 ultra-low offset/drift, adjustable gain, precision instrumentation amplifier in a μ MAX[®] package. The MAX4208 features high-impedance differential inputs optimized for small voltages ($\pm 100\text{mV}$ max) and provides rail-to-rail output. The MAX4208 EV kit is configured for a gain of 148V/V. The EV kit operates from a single-supply voltage between 2.85V and 5.5V, or dual supplies providing $\pm 1.425\text{V}$ to $\pm 2.75\text{V}$.

The MAX4208 EV kit can also be used to evaluate the MAX4209 fixed-gain amplifiers. The MAX4208 IC temperature range is -40°C to $+125^{\circ}\text{C}$.

The MAX4209 EV kit, available separately, evaluates the 100V/V fixed-gain MAX4209 amplifier without external gain-setting resistors.

Note: To evaluate a MAX4209 IC featuring internal gain-setting resistors, order a MAX4209EVKIT+ or request a free sample of the MAX4209 IC along with the MAX4208EVKIT+. See the *Part Selection Table* for IC ordering information.

Component List

DESIGNATION	QTY	DESCRIPTION
C1, C3	2	10 μF $\pm 10\%$, 10V X5R ceramic capacitors (0805) Murata GRM21BR61A106K KEMET C0805C106K8PAC
C2, C4, C5	3	0.1 μF $\pm 10\%$, 10V X5R ceramic capacitors (0402) Murata GRM155R61A104K KEMET C0402C104K8RACTU
C6, C7	0	Not installed, capacitors (0603)
C8	1	1000pF $\pm 10\%$, 16V X5R ceramic capacitor (0402) Murata GRM155R61C102K
JU1	1	4-pin header
JU2, JU3	2	2-pin headers
R1	1	1k Ω $\pm 0.1\%$ resistor (0805) IRC PCF-W0805LF-03-1001-B
R2	1	147k Ω $\pm 0.1\%$ resistor (0805) IRC PCF-W0805LF-03-1473-B
R3, R4	2	4.99k Ω $\pm 1\%$ resistors (0603)
R5, R6	0	Not installed, resistors—short (0603)
R7	0	Not installed, resistor (1206)
U1	1	MAX4208AUA+ (8-pin μ MAX)
—	3	Shunts
—	1	PCB: MAX4208 Evaluation Kit+

μ MAX is a registered trademark of Maxim Integrated Products, Inc.



For pricing, delivery, and ordering information, please contact Maxim Direct at 1-888-629-4642, or visit Maxim's website at www.maxim-ic.com.

Features

- ◆ Single- or Dual-Supply Operation
2.85V to 5.5V Single-Supply Operation
 $\pm 1.425\text{V}$ to $\pm 2.75\text{V}$ Dual-Supply Operation
- ◆ Adjustable Voltage Gain Configured to 148V/V
- ◆ Rail-to-Rail Output
- ◆ Configurable Reference Voltage: Externally or Internally Buffered
- ◆ Optional Current-Sense Mode
- ◆ Fully Assembled and Tested

Ordering Information

PART	TYPE
MAX4208EVKIT+	EV Kit

+Denotes lead-free and RoHS-compliant

Part Selection Table

PART	GAIN (V/V)
MAX4208AUA+	Adjustable
MAX4209TAUA+	10
MAX4209HAUA+	100
MAX4209KAUA+	1000

MAX4208 Evaluation Kit

Component Suppliers

SUPPLIER	PHONE	WEBSITE
IRC	361-992-7900	www.ircctt.com
KEMET Corp.	864-963-6300	www.kemet.com
Murata Mfg. Co., Ltd.	770-436-1300	www.murata.com

Note: Indicate that you are using the MAX4208 or MAX4209 when contacting these component suppliers.

Quick Start

Recommended Equipment

Before beginning, the following equipment is needed:

- 5V, 1A-rated DC power supply
- Function generator
- Oscilloscope

Procedure

The MAX4208 EV kit is fully assembled and tested. Follow the steps below to verify board operation.

Caution: Do not turn on the power supply until all connections are completed.

- 1) Verify that a shunt is installed across pins 1-4 of jumper JU1 (on-board buffered-reference mode).
- 2) Verify that a shunt is installed on jumper JU2 (single-supply operation).
- 3) Verify that a jumper is not installed on jumper JU3 (buffered-reference mode).
- 4) Set the DC power-supply output to 5V and disable the output.
- 5) Set the function generator output to a 10mV_{p-p}, 200Hz, 0V DC offset sine wave. Terminate the function generator as needed.
- 6) Connect the power-supply positive output to the VDD PCB pad on the EV kit.
- 7) Connect the power-supply ground to the GND PCB pad next to VDD on the EV kit.
- 8) Connect the function generator output across the differential input PCB pads, IN+ and IN-.
- 9) Connect the IN- PCB pad to the GND PCB pad with a wire.
- 10) Connect the oscilloscope to the OUT PCB pad and the oscilloscope ground clip to the GND PCB pad.
- 11) Enable the DC power supply and the function generator.
- 12) Verify that the oscilloscope measures a 1.48V_{p-p}, 200Hz, 2.5V DC offset sine wave.

Detailed Description

The MAX4208 EV kit evaluates the MAX4208 instrumentation amplifier that features adjustable gain with gain-setting resistors R1 and R2, low offset voltage, and low offset voltage drift. The output-voltage range is from VSS + 100mV, to VDD - 100mV. The MAX4208 EV kit voltage gain is configured to 148V/V. The EV kit operates from a single-supply voltage between 2.85V and 5.5V or from a dual-supply voltage providing $\pm 1.425V$ to $\pm 2.75V$.

The MAX4208 EV kit can evaluate the fixed-gain MAX4209 ICs in the 8-pin μ MAX package by replacing the MAX4208 IC U1 and removing resistors R1 and R2.

Power Supply

The MAX4208 EV kit jumper JU2 must be configured properly for single-supply or dual-supply operation. For single-supply operation, a single power supply is connected to VDD and GND. For dual-supply operation, connect a positive supply to VDD, a negative supply to VSS, and supply ground to GND. See Table 1 to configure jumper JU2.

Table 1. Power-Supply Configuration (Jumper JU2)

SHUNT POSITION	VSS PIN	EV KIT FUNCTION
Installed	Connected to GND	Single-supply operation. Power only VDD.
Not installed	Not connected	Dual-supply operation. Power VDD and VSS.

MAX4208 Evaluation Kit

Evaluates: MAX4208/MAX4209

REFIN/MODE Operation Modes

The EV kit jumper JU1 configures the MAX4208 for direct reference, buffered reference, or shutdown mode. The reference voltage at REF sets the output voltage DC signal, OUT, when the differential input signal $V_{IN+} - V_{IN-}$ equals zero. In direct-reference-mode operation, connect a user reference voltage directly to the REF PCB pad. In buffered-reference-mode operation, connect a user reference voltage to the REFIN/MODE input PCB pad or use the resistor-divider network R3 and R4 to provide a reference voltage for REFIN/MODE, scaled from VDD. The network is configured to scale the voltage at REFIN/MODE to one-half of VDD. Replace resistors R3 and R4 to modify the voltage applied to REFIN/MODE using the following equation:

$$V_{REFIN/MODE} = VDD \times \left(\frac{R4}{R3 + R4} \right)$$

where VDD is the input supply voltage to the EV kit.

In buffered-reference mode, the MAX4208 internally buffers the REFIN/MODE voltage onto REF.

Note: Do not connect an external source to the REF PCB pad in buffered-reference mode. See Table 2 for jumper JU1 configurations.

REF Input

The EV kit's jumper JU3 must be configured properly for appropriate reference-voltage operation. In direct reference mode, install a shunt on jumper JU3 to connect REF to the on-board ground (GND), or remove the shunt to connect a user reference voltage to the REF input PCB pad. For either buffered-reference mode, REF must not be connected to a reference voltage; thus, the shunt on jumper JU3 must not be installed. See Table 2 for jumper JU3 configurations.

Optional capacitor C6 can be used for reference-voltage stability/filtering. Choose an appropriate value as needed.

On-Board Current Sensing

The MAX4208 EV kit can be configured for on-board current sensing by installing a surface-mount 1206 sense resistor at R7, located between the IN+ and IN- PCB pads. Use the following equation to select the value for resistor R7:

$$R7 = \frac{30mV}{I_{IN}}$$

where I_{IN} is the maximum current flowing across resistor R7 and 30mV is a suggested sense voltage. 30mV x 148V/V gives a 4.4V output swing. Refer to the

Table 2. Jumpers JU1 and JU3 Configurations

MODE	JU1 SHUNT POSITION	REFIN/MODE PIN	JU3 SHUNT POSITION	REF PIN	EV KIT FUNCTION
Direct-reference-mode operation	1-2	Connected to VSS	Installed	Connected to GND	JU1 disables the internal REF buffer. JU3 sets the REF voltage to GND.
			Not installed	Connected to user reference voltage	JU1 disables the internal REF buffer. JU3 allows the user to set the REF voltage directly. Apply a user reference voltage to the REF PCB pad in the 0V and VDD - 1.6V range.
Shutdown mode	1-3	Connected to VDD	—	—	Entire IC is in shutdown. $I_{CC} < 5\mu A$.
Buffered-reference-mode operation (on-board reference)	1-4	Connected to VDD / 2	Not installed	Not connected	The IC buffers the on-board VDD / 2 onto REF. Do not install JU3 or connect an external source to the REF PCB pad.
Buffered-reference-mode operation (user reference)	Not installed	Connected to user reference voltage	Not installed	Not connected	The IC buffers a user reference voltage onto REF. Apply a user reference voltage to the REFIN/MODE PCB pad in the range of VSS + 200mV and VDD - 1.6V. Do not install JU3 or connect an external source to the REF PCB pad.

MAX4208 Evaluation Kit

MAX4208/MAX4209 IC data sheet for application details. Verify that the selected resistor is rated for the appropriate current and power levels.

For high-power applications, use the IN+ and IN- PCB pads as sense connections to an off-board current-sense resistor.

Differential Input Filter

The MAX4208 EV kit features an optional balanced-differential resistor-capacitor filter across the MAX4208 IN+ and IN- input pins. Use the surface-mount 0603 PCB pads for installing resistors R5, R6, and capacitor C7, which form the filter. Before installing resistors R5 and R6, cut open the shorting PCB trace located at the respective pads.

Gain Setting

The MAX4208 EV kit gain is configured to 148V/V by resistors R1 and R2. Replacing these resistors with

high-precision, surface-mount 0805 resistors can change the gain. Tolerance of $\pm 0.1\%$ or better is recommended for optimum performance. Use the following equation to select values for resistors R1 and R2:

$$R2 = R1 \times (\text{Gain} - 1)$$

where $R1 \leq 1\text{k}\Omega$ and the sum of $R1 + R2$ is $10\text{k}\Omega \leq (R1 + R2) \leq 500\text{k}\Omega$.

Evaluating the MAX4209

The MAX4208 EV kit can be used to evaluate the fixed-gain MAX4209 IC in the 8-pin μMAX package by replacing the MAX4208 IC U1 and removing resistors R1 and R2. The MAX4209 IC features fixed gains of 10V/V, 100V/V, or 1000V/V. See the *Part Selection Table* for ordering information.

The MAX4209 EV kit is also available separately.

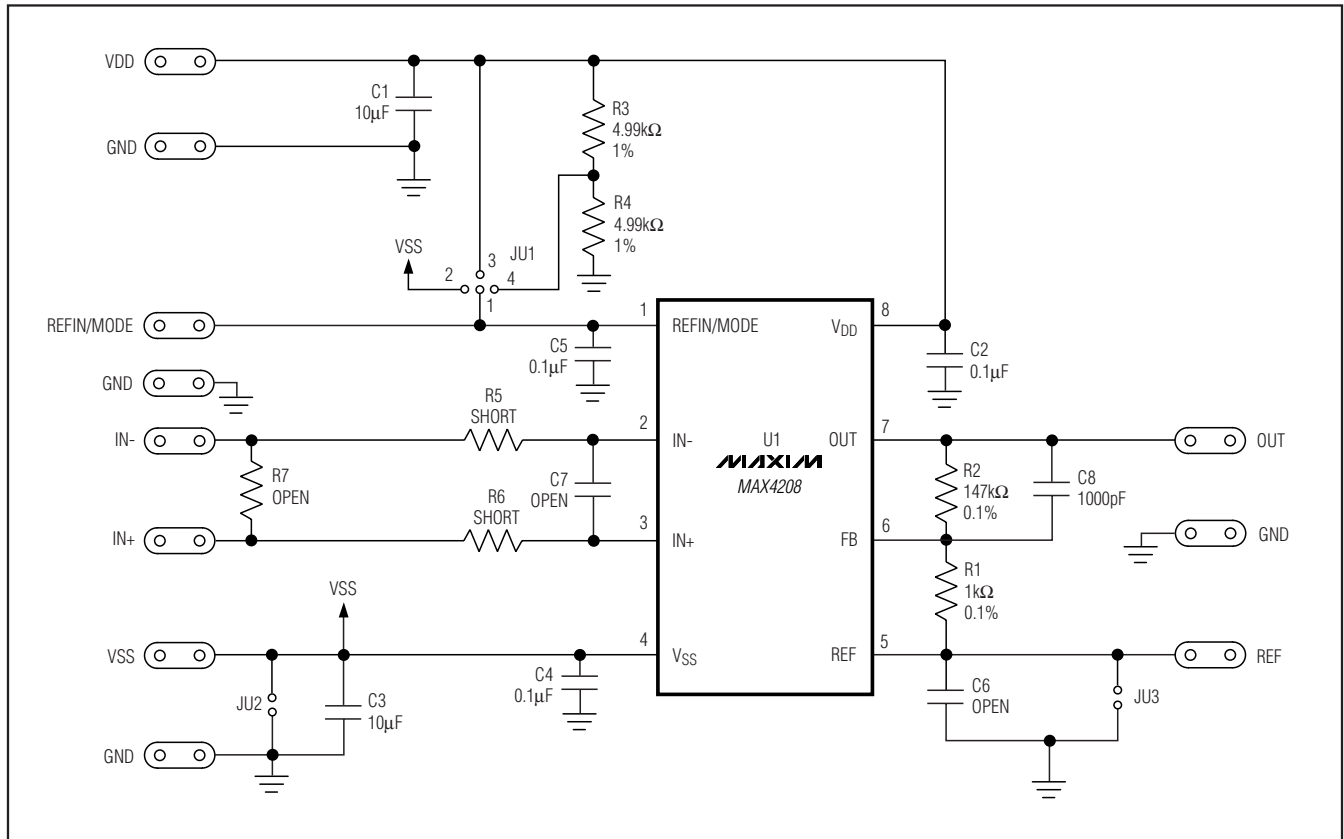

Figure 1. MAX4208 EV Kit Schematic

MAX4208 Evaluation Kit

Evaluates: MAX4208/MAX4209

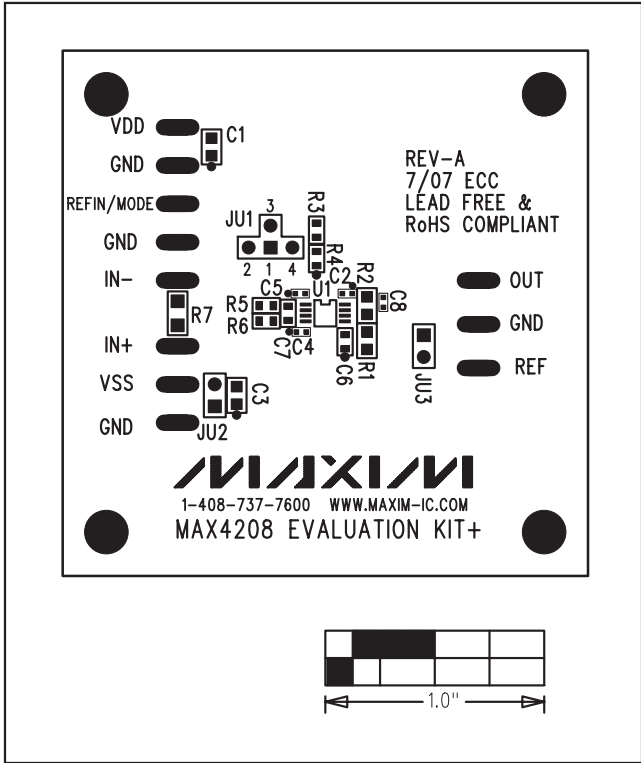

Figure 2. MAX4208 EV Kit Component Placement Guide—(Component Side)

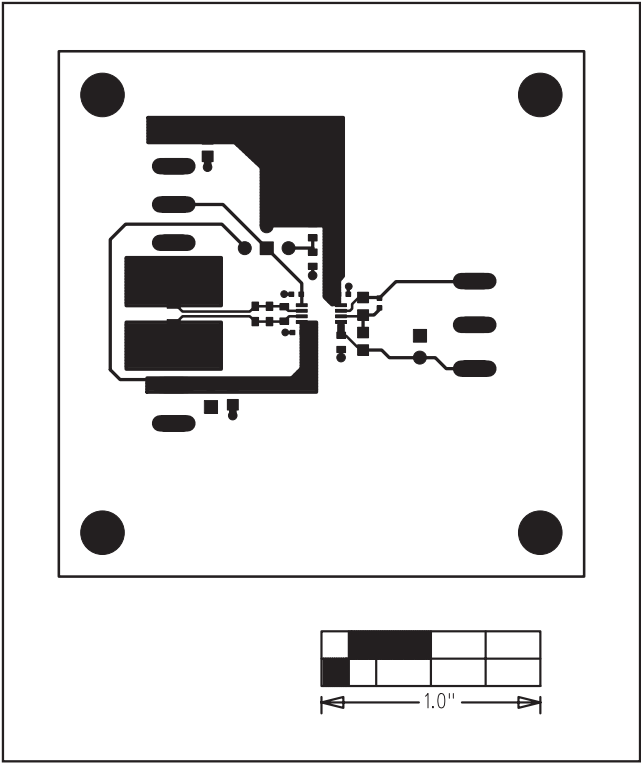

Figure 3. MAX4208 EV Kit PCB Layout—Component Side

MAX4208 Evaluation Kit

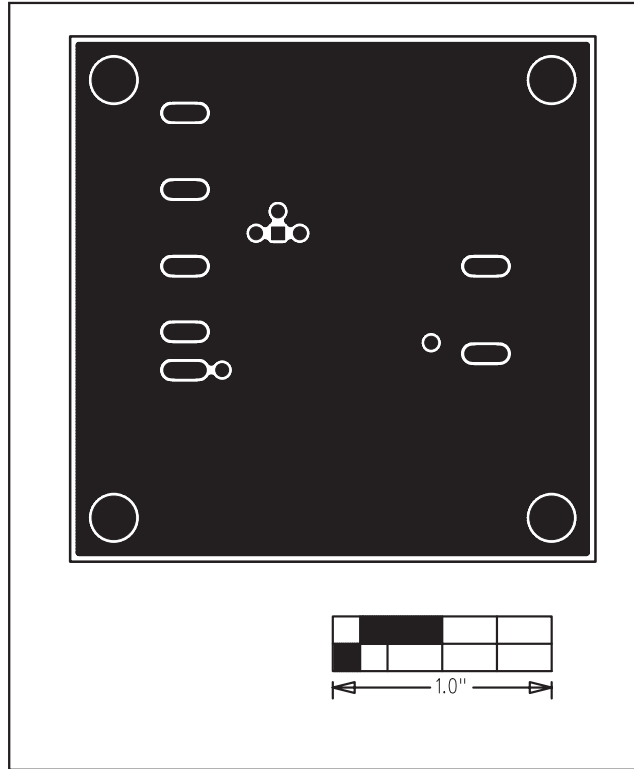

Figure 4. MAX4208 EV Kit PCB Layout—Solder Side

Maxim cannot assume responsibility for use of any circuitry other than circuitry entirely embodied in a Maxim product. No circuit patent licenses are implied. Maxim reserves the right to change the circuitry and specifications without notice at any time.

6 **Maxim Integrated Products, 120 San Gabriel Drive, Sunnyvale, CA 94086 408-737-7600**

© 2007 Maxim Integrated Products

MAXIM is a registered trademark of Maxim Integrated Products, Inc.

Компания «Life Electronics» занимается поставками электронных компонентов импортного и отечественного производства от производителей и со складов крупных дистрибьюторов Европы, Америки и Азии.

С конца 2013 года компания активно расширяет линейку поставок компонентов по направлению коаксиальный кабель, кварцевые генераторы и конденсаторы (керамические, пленочные, электролитические), за счёт заключения дистрибьюторских договоров

Мы предлагаем:

- Конкурентоспособные цены и скидки постоянным клиентам.
- Специальные условия для постоянных клиентов.
- Подбор аналогов.
- Поставку компонентов в любых объемах, удовлетворяющих вашим потребностям.
- Приемлемые сроки поставки, возможна ускоренная поставка.
- Доставку товара в любую точку России и стран СНГ.
- Комплексную поставку.
- Работу по проектам и поставку образцов.
- Формирование склада под заказчика.
- Сертификаты соответствия на поставляемую продукцию (по желанию клиента).
- Тестирование поставляемой продукции.
- Поставку компонентов, требующих военную и космическую приемку.
- Входной контроль качества.
- Наличие сертификата ISO.

В составе нашей компании организован Конструкторский отдел, призванный помогать разработчикам, и инженерам.

Конструкторский отдел помогает осуществить:

- Регистрацию проекта у производителя компонентов.
- Техническую поддержку проекта.
- Защиту от снятия компонента с производства.
- Оценку стоимости проекта по компонентам.
- Изготовление тестовой платы монтаж и пусконаладочные работы.



Тел: +7 (812) 336 43 04 (многоканальный)

Email: org@lifeelectronics.ru