

Redundancy module - QUINT-ORING/24DC/2X20/1X40 - 2320186

Please be informed that the data shown in this PDF Document is generated from our Online Catalog. Please find the complete data in the user's documentation. Our General Terms of Use for Downloads are valid (<http://download.phoenixcontact.com>)



Active QUINT redundancy module for DIN rail mounting with integrated SFB (selective fuse breaking) technology and monitoring functions, input: 24 V DC, output: 24 V DC/2 x 20 A or 1 x 40 A, including mounted universal DIN rail adapter UTA 107/30

Product Features

- Service life of the redundant solution is doubled, thanks to uniform distribution of the load
- Save energy
- Permanent monitoring of redundancy
- Consistent redundancy up to the load



Key commercial data

Packing unit	1 PCE
GTIN	 4 046356 524919
Custom tariff number	85044090
Country of origin	CHINA

Technical data

Input data

Nominal input voltage	24 V DC
Nominal input voltage range	<p></p>
Nominal input voltage range	18 V DC ... 28 V DC (SELV)
Input voltage range DC	<p></p>
Type of protection	Protection against static surge voltages > 30 V
Nominal input current I _N	2x 20 A (-25 °C ... 60 °C)
Nominal input current I _N	1x 40 A (-25 °C ... 60 °C)

Redundancy module - QUINT-ORING/24DC/2X20/1X40 - 2320186

Technical data

Input data

Maximum current I_{max}	2x 26 A (-25°C ... 40°C)
Maximum current I_{max}	1x 52 A (-25°C ... 40°C)

Output data

Nominal output voltage	0.2 V (< DC input)
Output current	40 A (Increasing power)
Output current	20 A (Redundancy)
Derating	60 °C ... 70 °C (2.5%/K)
Power loss nominal load max.	8 W ($I_{OUT} = 40$ A)

General data

Width	38 mm
Height	130 mm
Depth	125 mm
Width with alternative assembly	122 mm
Height with alternative assembly	130 mm
Depth with alternative assembly	41 mm
Net weight	0.6 kg
Efficiency	> 98 %
Degree of protection	IP20
Protection class	III
MTBF (IEC 61709, SN 29500)	> 720000 h (According to EN 29500)
Ambient temperature (operation)	-25 °C ... 70 °C (> 60 °C derating)
Ambient temperature (storage/transport)	-40 °C ... 85 °C
Max. permissible relative humidity (operation)	≤ 95 % (at 25 °C, no condensation)
Mounting position	horizontal DIN rail NS 35, EN 60715
Assembly instructions	Alignable: 5 mm horizontally, 15 mm next to active components, 50 mm vertically
Electromagnetic compatibility	Conformance with EMC Directive 2004/108/EC
Noise immunity	EN 61000-6-2:2005
Low Voltage Directive	Conformance with LV directive 2006/95/EC
Standard – Electrical equipment of machines	EN 60204
Standard - Electrical safety	EN 60950-1/VDE 0805 (SELV)
Standard – Electronic equipment for use in electrical power installations and their assembly into electrical power installations	EN 50178/VDE 0160 (PELV)
Standard – Safety extra-low voltage	IEC 60950-1 (SELV) and EN 60204 (PELV)
UL approvals	UL/C-UL listed UL 508
UL approvals	UL/C-UL Recognized UL 60950

Redundancy module - QUINT-ORING/24DC/2X20/1X40 - 2320186

Technical data

General data

UL approvals	UL ANSI/ISA-12.12.01 Class I, Division 2, Groups A, B, C, D (Hazardous Location)
--------------	--

Connection data, input

Connection method	Screw connection
Conductor cross section solid min.	0.2 mm ²
Conductor cross section solid max.	6 mm ²
Conductor cross section stranded min.	0.2 mm ²
Conductor cross section stranded max.	4 mm ²
Conductor cross section AWG/kcmil min.	10
Stripping length	8 mm
Screw thread	M3

Connection data, output

Connection method	Screw connection
Conductor cross section solid min.	0.5 mm ²
Conductor cross section solid max.	16 mm ²
Conductor cross section stranded min.	0.5 mm ²
Conductor cross section stranded max.	16 mm ²
Conductor cross section AWG/kcmil min.	6
Stripping length	10 mm

Signaling

Output name	Redundancy OK, 13/14
Output description	Group contact
Maximum switching voltage	max. 30 V AC/DC
Maximum inrush current	≤ 100 mA (short-circuit resistant)
Status display	LED redundancy OK
Note on status display	Green
Conductor cross section solid min.	0.2 mm ²
Conductor cross section solid max.	6 mm ²
Conductor cross section stranded min.	0.2 mm ²
Conductor cross section stranded max.	4 mm ²
Conductor cross section AWG/kcmil min.	16
Conductor cross section AWG/kcmil max	10
Tightening torque, min	0.5 Nm
Tightening torque max	0.6 Nm
Screw thread	M3
Output name	ACB (Auto Current Balancing) OK, 23/24

Redundancy module - QUINT-ORING/24DC/2X20/1X40 - 2320186

Technical data

Signaling

Output description	Contact closed: $\Delta U_{IN} \leq 300 \text{ mV}$
Maximum switching voltage	max. 30 V AC/DC
Maximum inrush current	$\leq 100 \text{ mA}$ (short-circuit resistant)
Status display	ACB OK LED
Note on status display	LED bar graph green

Classifications

ETIM

ETIM 3.0	EC000599
ETIM 4.0	EC000599
ETIM 5.0	EC000599

UNSPSC

UNSPSC 11	39121004
UNSPSC 12.01	39121004
UNSPSC 13.2	39121004
UNSPSC 6.01	30211502
UNSPSC 7.0901	39121004

eCl@ss

eCl@ss 4.0	27250311
eCl@ss 4.1	27250311
eCl@ss 5.0	27242213
eCl@ss 5.1	27242213
eCl@ss 6.0	27049005
eCl@ss 7.0	27049005

Approvals

Approvals

Approvals

UL Recognized / UL Listed / cUL Recognized / cUL Listed / RINA / GL / cULus Recognized / cULus Listed

Ex Approvals

UL Listed / cUL Listed / IECEx / ATEX / cULus Listed

Redundancy module - QUINT-ORING/24DC/2X20/1X40 - 2320186

Approvals

Approvals submitted

Approval details

UL Recognized 

UL Listed 

cUL Recognized 

cUL Listed 

RINA

GL

cULus Recognized 

cULus Listed 

Accessories

Accessories

Redundancy module - QUINT-ORING/24DC/2X20/1X40 - 2320186

Accessories

Assembly adapters - UTA 107/30 - 2320089



Universal DIN rail adapter

Assembly adapters - UWA 182/52 - 2938235



Universal wall adapter

Assembly adapters - QUINT-PS-ADAPTERS7/1 - 2938196



Assembly adapter for QUINT-PS... power supply on S7-300 rail

Drawings

Redundancy module - QUINT-ORING/24DC/2X20/1X40 - 2320186

Block diagram

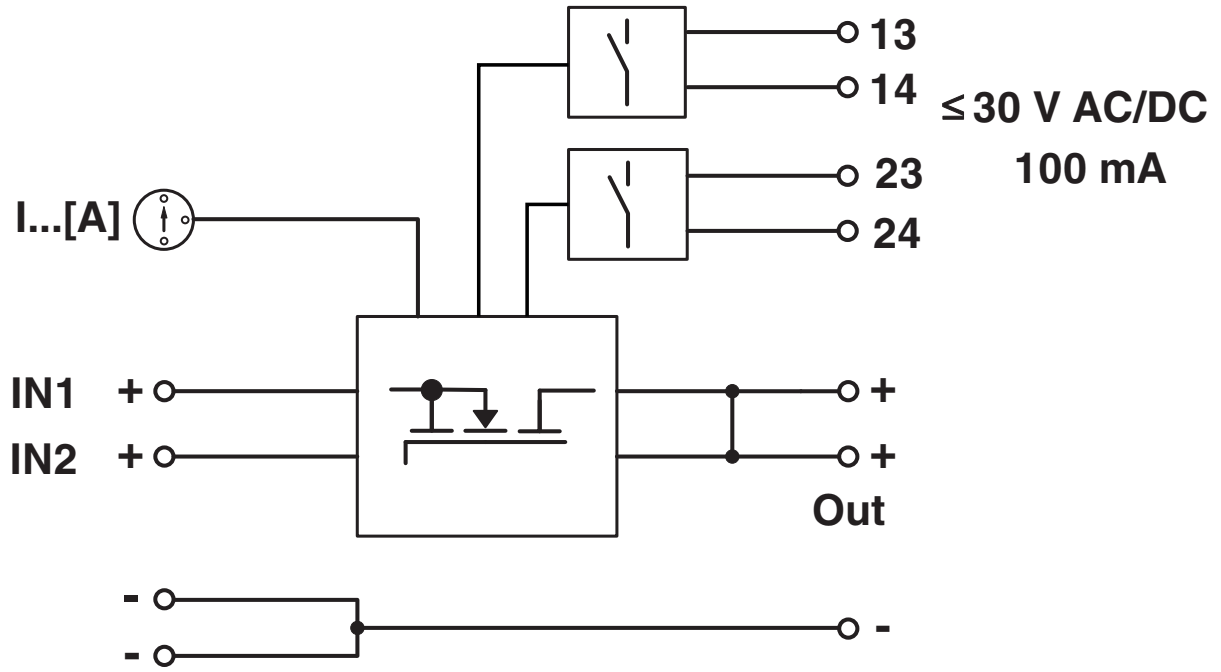

Компания «Life Electronics» занимается поставками электронных компонентов импортного и отечественного производства от производителей и со складов крупных дистрибьюторов Европы, Америки и Азии.

С конца 2013 года компания активно расширяет линейку поставок компонентов по направлению коаксиальный кабель, кварцевые генераторы и конденсаторы (керамические, пленочные, электролитические), за счёт заключения дистрибьюторских договоров

Мы предлагаем:

- Конкурентоспособные цены и скидки постоянным клиентам.
- Специальные условия для постоянных клиентов.
- Подбор аналогов.
- Поставку компонентов в любых объемах, удовлетворяющих вашим потребностям.
- Приемлемые сроки поставки, возможна ускоренная поставка.
- Доставку товара в любую точку России и стран СНГ.
- Комплексную поставку.
- Работу по проектам и поставку образцов.
- Формирование склада под заказчика.
- Сертификаты соответствия на поставляемую продукцию (по желанию клиента).
- Тестирование поставляемой продукции.
- Поставку компонентов, требующих военную и космическую приемку.
- Входной контроль качества.
- Наличие сертификата ISO.

В составе нашей компании организован Конструкторский отдел, призванный помогать разработчикам, и инженерам.

Конструкторский отдел помогает осуществить:

- Регистрацию проекта у производителя компонентов.
- Техническую поддержку проекта.
- Защиту от снятия компонента с производства.
- Оценку стоимости проекта по компонентам.
- Изготовление тестовой платы монтаж и пусконаладочные работы.



Тел: +7 (812) 336 43 04 (многоканальный)
Email: org@lifeelectronics.ru