

Cat. No. W165-E1-04

**SYSMAC**  
**C200H-ASC02**  
**ASCII Unit**

**OPERATION MANUAL**

**OMRON®**



# C200H-ASC02 ASCII Unit

## Operation Manual

*Revised September 2002*

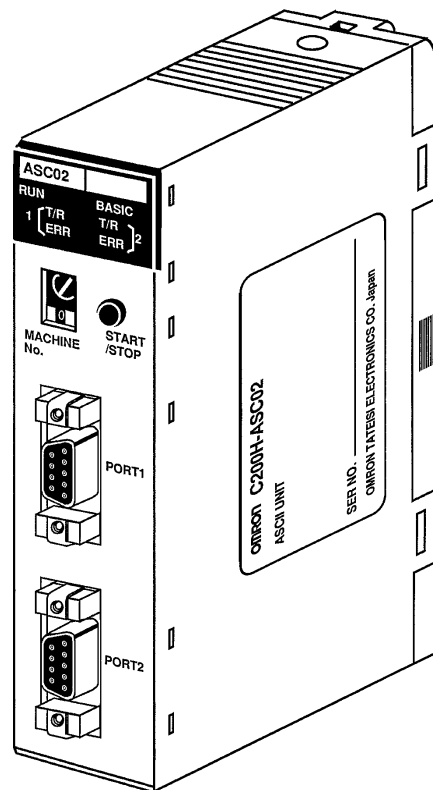

# Terms and Conditions of Sale

1. **Offer; Acceptance.** These terms and conditions (these "Terms") are deemed part of all quotes, agreements, purchase orders, acknowledgments, price lists, catalogs, manuals, brochures and other documents, whether electronic or in writing, relating to the sale of products or services (collectively, the "Products") by Omron Electronics LLC and its subsidiary companies ("Omron"). Omron objects to any terms or conditions proposed in Buyer's purchase order or other documents which are inconsistent with, or in addition to, these Terms.
2. **Prices; Payment Terms.** All prices stated are current, subject to change without notice by Omron. Omron reserves the right to increase or decrease prices on any unshipped portions of outstanding orders. Payments for Products are due net 30 days unless otherwise stated in the invoice.
3. **Discounts.** Cash discounts, if any, will apply only on the net amount of invoices sent to Buyer after deducting transportation charges, taxes and duties, and will be allowed only if (i) the invoice is paid according to Omron's payment terms and (ii) Buyer has no past due amounts.
4. **Interest.** Omron, at its option, may charge Buyer 1-1/2% interest per month or the maximum legal rate, whichever is less, on any balance not paid within the stated terms.
5. **Orders.** Omron will accept no order less than \$200 net billing.
6. **Governmental Approvals.** Buyer shall be responsible for, and shall bear all costs involved in, obtaining any government approvals required for the importation or sale of the Products.
7. **Taxes.** All taxes, duties and other governmental charges (other than general real property and income taxes), including any interest or penalties thereon, imposed directly or indirectly on Omron or required to be collected directly or indirectly by Omron for the manufacture, production, sale, delivery, importation, consumption or use of the Products sold hereunder (including customs duties and sales, excise, use, turnover and license taxes) shall be charged to and remitted by Buyer to Omron.
8. **Financial.** If the financial position of Buyer at any time becomes unsatisfactory to Omron, Omron reserves the right to stop shipments or require satisfactory security or payment in advance. If Buyer fails to make payment or otherwise comply with these Terms or any related agreement, Omron may (without liability and in addition to other remedies) cancel any unshipped portion of Products sold hereunder and stop any Products in transit until Buyer pays all amounts, including amounts payable hereunder, whether or not then due, which are owing to it by Buyer. Buyer shall in any event remain liable for all unpaid accounts.
9. **Cancellation; Etc.** Orders are not subject to rescheduling or cancellation unless Buyer indemnifies Omron against all related costs or expenses.
10. **Force Majeure.** Omron shall not be liable for any delay or failure in delivery resulting from causes beyond its control, including earthquakes, fires, floods, strikes or other labor disputes, shortage of labor or materials, accidents to machinery, acts of sabotage, riots, delay in or lack of transportation or the requirements of any government authority.
11. **Shipping; Delivery.** Unless otherwise expressly agreed in writing by Omron:
  - a. Shipments shall be by a carrier selected by Omron; Omron will not drop ship except in "break down" situations.
  - b. Such carrier shall act as the agent of Buyer and delivery to such carrier shall constitute delivery to Buyer;
  - c. All sales and shipments of Products shall be FOB shipping point (unless otherwise stated in writing by Omron), at which point title and risk of loss shall pass from Omron to Buyer; provided that Omron shall retain a security interest in the Products until the full purchase price is paid;
  - d. Delivery and shipping dates are estimates only; and
  - e. Omron will package Products as it deems proper for protection against normal handling and extra charges apply to special conditions.
12. **Claims.** Any claim by Buyer against Omron for shortage or damage to the Products occurring before delivery to the carrier must be presented in writing to Omron within 30 days of receipt of shipment and include the original transportation bill signed by the carrier noting that the carrier received the Products from Omron in the condition claimed.
13. **Warranties.** (a) **Exclusive Warranty.** Omron's exclusive warranty is that the Products will be free from defects in materials and workmanship for a period of twelve months from the date of sale by Omron (or such other period expressed in writing by Omron). Omron disclaims all other warranties, express or implied. (b) **Limitations.** OMRON MAKES NO WARRANTY OR REPRESENTATION, EXPRESS OR IMPLIED, ABOUT NON-INFRINGEMENT, MERCHANTABILITY OR FITNESS FOR A PARTICULAR PURPOSE OF THE PRODUCTS. BUYER ACKNOWLEDGES THAT IT ALONE HAS DETERMINED THAT THE PRODUCTS WILL SUITABLY MEET THE REQUIREMENTS OF THEIR INTENDED USE. Omron further disclaims all warranties and responsibility of any type for claims or expenses based on infringement by the Products or otherwise of any intellectual property right. (c) **Buyer Remedy.** Omron's sole obligation hereunder shall be, at Omron's election, to (i) replace (in the form originally shipped with Buyer responsible for labor charges for removal or replacement thereof) the non-complying Product, (ii) repair the non-complying Product, or (iii) repay or credit Buyer an amount equal to the purchase price of the non-complying Product; provided that in no event shall Omron be responsible for warranty, repair, indemnity or any other claims or expenses regarding the Products unless Omron's analysis confirms that the Products were properly handled, stored, installed and maintained and not subject to contamination, abuse, misuse or inappropriate modification. Return of any Products by Buyer must be approved in writing by Omron before shipment. Omron Companies shall not be liable for the suitability or unsuitability or the results from the use of Products in combination with any electrical or electronic components, circuits, system assemblies or any other materials or substances or environments. Any advice, recommendations or information given orally or in writing, are not to be construed as an amendment or addition to the above warranty. See <http://oeweb.omron.com> or contact your Omron representative for published information.
14. **Limitation on Liability; Etc.** OMRON COMPANIES SHALL NOT BE LIABLE FOR SPECIAL, INDIRECT, INCIDENTAL, OR CONSEQUENTIAL DAMAGES, LOSS OF PROFITS OR PRODUCTION OR COMMERCIAL LOSS IN ANY WAY CONNECTED WITH THE PRODUCTS, WHETHER SUCH CLAIM IS BASED IN CONTRACT, WARRANTY, NEGLIGENCE OR STRICT LIABILITY. Further, in no event shall liability of Omron Companies exceed the individual price of the Product on which liability is asserted.
15. **Indemnities.** Buyer shall indemnify and hold harmless Omron Companies and their employees from and against all liabilities, losses, claims, costs and expenses (including attorney's fees and expenses) related to any claim, investigation, litigation or proceeding (whether or not Omron is a party) which arises or is alleged to arise from Buyer's acts or omissions under these Terms or in any way with respect to the Products. Without limiting the foregoing, Buyer (at its own expense) shall indemnify and hold harmless Omron and defend or settle any action brought against such Companies to the extent based on a claim that any Product made to Buyer specifications infringed intellectual property rights of another party.
16. **Property; Confidentiality.** Any intellectual property in the Products is the exclusive property of Omron Companies and Buyer shall not attempt to duplicate it in any way without the written permission of Omron. Notwithstanding any charges to Buyer for engineering or tooling, all engineering and tooling shall remain the exclusive property of Omron. All information and materials supplied by Omron to Buyer relating to the Products are confidential and proprietary, and Buyer shall limit distribution thereof to its trusted employees and strictly prevent disclosure to any third party.
17. **Export Controls.** Buyer shall comply with all applicable laws, regulations and licenses regarding (i) export of products or information; (iii) sale of products to "forbidden" or other proscribed persons; and (ii) disclosure to non-citizens of regulated technology or information.
18. **Miscellaneous:** (a) **Waiver.** No failure or delay by Omron in exercising any right and no course of dealing between Buyer and Omron shall operate as a waiver of rights by Omron. (b) **Assignment.** Buyer may not assign its rights hereunder without Omron's written consent. (c) **Law.** These Terms are governed by the law of the jurisdiction of the home office of the Omron company from which Buyer is purchasing the Products (without regard to conflict of law principles). (d) **Amendment.** These Terms constitute the entire agreement between Buyer and Omron relating to the Products, and no provision may be changed or waived unless in writing signed by the parties. (e) **Severability.** If any provision hereof is rendered ineffective or invalid, such provision shall not invalidate any other provision. (f) **Setoff.** Buyer shall have no right to set off any amounts against the amount owing in respect of this invoice. (g) **Definitions.** As used herein, "including" means "including without limitation"; and "Omron Companies" (or similar words) mean Omron Corporation and any direct or indirect subsidiary or affiliate thereof.

## Certain Precautions on Specifications and Use

1. **Suitability of Use.** Omron Companies shall not be responsible for conformity with any standards, codes or regulations which apply to the combination of the Product in the Buyer's application or use of the Product. At Buyer's request, Omron will provide applicable third party certification documents identifying ratings and limitations of use which apply to the Product. This information by itself is not sufficient for a complete determination of the suitability of the Product in combination with the end product, machine, system, or other application or use. Buyer shall be solely responsible for determining appropriateness of the particular Product with respect to Buyer's application, product or system. Buyer shall take application responsibility in all cases but the following is a non-exhaustive list of applications for which particular attention must be given: (i) Outdoor use, uses involving potential chemical contamination or electrical interference, or conditions or uses not described in this document. (ii) Use in consumer products or any use in significant quantities. (iii) Energy control systems, combustion systems, railroad systems, aviation systems, medical equipment, amusement machines, vehicles, safety equipment, and installations subject to separate industry or government regulations. (iv) Systems, machines and equipment that could present a risk to life or property. Please know and observe all prohibitions of use applicable to this Product.  
NEVER USE THE PRODUCT FOR AN APPLICATION INVOLVING SERIOUS RISK TO LIFE OR PROPERTY OR IN LARGE QUANTITIES WITHOUT ENSURING THAT THE SYSTEM AS A WHOLE HAS BEEN DESIGNED TO ADDRESS THE RISKS, AND THAT THE OMRON'S PRODUCT IS PROPERLY RATED AND INSTALLED FOR THE INTENDED USE WITHIN THE OVERALL EQUIPMENT OR SYSTEM.
2. **Programmable Products.** Omron Companies shall not be responsible for the user's programming of a programmable Product, or any consequence thereof.
3. **Performance Data.** Data presented in Omron Company websites, catalogs and other materials is provided as a guide for the user in determining suitability and does not constitute a warranty. It may represent the result of Omron's test conditions, and the user must correlate it to actual application requirements. Actual performance is subject to the Omron's Warranty and Limitations of Liability.
4. **Change in Specifications.** Product specifications and accessories may be changed at any time based on improvements and other reasons. It is our practice to change part numbers when published ratings or features are changed, or when significant construction changes are made. However, some specifications of the Product may be changed without any notice. When in doubt, special part numbers may be assigned to fix or establish key specifications for your application. Please consult with your Omron's representative at any time to confirm actual specifications of purchased Product.
5. **Errors and Omissions.** Information presented by Omron Companies has been checked and is believed to be accurate; however, no responsibility is assumed for clerical, typographical or proofreading errors or omissions.

## **Notice:**

OMRON products are manufactured for use according to proper procedures by a qualified operator and only for the purposes described in this manual.

The following conventions are used to indicate and classify precautions in this manual. Always heed the information provided with them. Failure to heed precautions can result in injury to people or damage to property.

 **DANGER** Indicates an imminently hazardous situation which, if not avoided, will result in death or serious injury.

 **WARNING** Indicates a potentially hazardous situation which, if not avoided, could result in death or serious injury.

 **Caution** Indicates a potentially hazardous situation which, if not avoided, may result in minor or moderate injury, or property damage.

## **OMRON Product References**

All OMRON products are capitalized in this manual. The word “Unit” is also capitalized when it refers to an OMRON product, regardless of whether or not it appears in the proper name of the product.

The abbreviation “Ch,” which appears in some displays and on some OMRON products, often means “word” and is abbreviated “Wd” in documentation in this sense.

The abbreviation “PC” means Programmable Controller and is not used as an abbreviation for anything else.

## **Visual Aids**

The following headings appear in the left column of the manual to help you locate different types of information.

**Note** Indicates information of particular interest for efficient and convenient operation of the product.

**1, 2, 3...** 1. Indicates lists of one sort or another, such as procedures, checklists, etc.

## **© OMRON, 1989**

All rights reserved. No part of this publication may be reproduced, stored in a retrieval system, or transmitted, in any form, or by any means, mechanical, electronic, photocopying, recording, or otherwise, without the prior written permission of OMRON.

No patent liability is assumed with respect to the use of the information contained herein. Moreover, because OMRON is constantly striving to improve its high-quality products, the information contained in this manual is subject to change without notice. Every precaution has been taken in the preparation of this manual. Nevertheless, OMRON assumes no responsibility for errors or omissions. Neither is any liability assumed for damages resulting from the use of the information contained in this publication.



# TABLE OF CONTENTS

<b>PRECAUTIONS</b> .....	<b>xi</b>
1 Intended Audience .....	xii
2 General Precautions .....	xii
3 Safety Precautions .....	xii
4 Operating Environment Precautions .....	xii
5 Application Precautions .....	xiii
<b>SECTION 1</b>	
<b>Hardware</b> .....	<b>1</b>
1-1 Front Panel .....	2
1-2 Back Panel .....	4
1-3 System Configuration .....	7
<b>SECTION 2</b>	
<b>Data Section</b> .....	<b>9</b>
2-1 Bits and Bytes .....	10
2-2 Data Section .....	11
<b>SECTION 3</b>	
<b>Programming and Communication</b> .....	<b>15</b>
3-1 Programs .....	16
3-2 Program Transfer .....	17
3-3 Running the BASIC Program .....	18
3-4 Assembly Routines .....	18
<b>SECTION 4</b>	
<b>BASIC Language</b> .....	<b>19</b>
4-1 Program Configuration .....	20
4-2 BASIC Language .....	25
<b>SECTION 5</b>	
<b>Assembly Programming</b> .....	<b>67</b>
5-1 Assembly Language Programming .....	68
5-2 Terminology and Formatting .....	69
5-3 Monitor Mode Commands .....	69
<b>SECTION 6</b>	
<b>Program Examples</b> .....	<b>79</b>
6-1 Example Programs .....	80
6-2 Execution Sequence .....	94
6-3 Assembly Language Example .....	102
<b>Appendices</b>	
A Standard Models .....	107
B Specifications .....	109
C PC Statements and Refresh Timing .....	117
D Formatting and Data Conversion .....	125
E ASCII Unit Memory Map .....	135
F Troubleshooting .....	141
G Reference Tables .....	145
H Programming with Windows 95 HyperTerminal .....	151
I Assembly Language Programming with a Terminal .....	155

## TABLE OF CONTENTS

<b>Glossary</b> .....	<b>159</b>
<b>Index</b> .....	<b>163</b>
<b>Revision History</b> .....	<b>165</b>



## About this Manual:

It has been assumed in the writing of this manual that the reader is already familiar with the hardware, programming, and terminology of OMRON PCs. If a review of this information is necessary, the reader should refer to the appropriate OMRON PC manuals for assistance.

This manual is organized into six topic sections and six supplementary appendixes and was designed to be read from the beginning to the end in the presented sequence. It is important to fully study the current section before proceeding to the following section. However, because many of the concepts presented are interrelated, in some circumstances it will not be possible to fully understand a topic until the reader has read the whole manual. Therefore, it is recommended that the user read the manual through once for general understanding and then again to fill in the details. This manual also contains an index and a glossary of important terms. It is recommended that the reader become familiar with the terms in the glossary before attempting to read this manual.

**Section 1** explains the details of the external hardware of the ASCII Unit and how it connects to a PC system.

**Section 2** explains the format of the PC data section. The PC data section is an area in the PC memory where the ASCII Unit and the PC exchange data.

**Section 3** explains how the ASCII Unit program and the PC Program communicate. It also explains how to write, load, save, and run an ASCII Unit BASIC program.

**Section 4** presents the ASCII Unit BASIC programming language. Since many of the BASIC commands are nonstandard and particular to an ASCII Unit-PC system, it is recommended that even readers already proficient in BASIC pay careful attention to this section.

**Section 5** explains the assembly language programming environment and how it relates to the ASCII Unit BASIC program. It also explains in detail how to write, edit, and run an assembly language program.

**Section 6** presents programming examples that are meant to bring together all of the concepts presented in this manual. Most of the programs deal with data transfer and illustrate how the ASCII Unit and the PC work together in various applications. Also in this section are several examples used to illustrate the execution sequence of the hardware during execution of the ASCII Unit and PC programs. Most of the detailed technical information not immediately necessary for the understanding of a particular section has been put into one of the six appendixes and should be used for reference when needed. For a list of the appendixes, refer to the table of contents.

**Appendixes**, a **Glossary**, and an **Index** are also included.



**WARNING** Failure to read and understand the information provided in this manual may result in personal injury or death, damage to the product, or product failure. Please read each section in its entirety and be sure you understand the information provided in the section and related sections before attempting any of the procedures or operations given.



# PRECAUTIONS

This section provides general precautions for using the C200H Temperature Sensor Unit and related devices.

**The information contained in this section is important for the safe and reliable application of the C200H Temperature Sensor Unit. You must read this section and understand the information contained before attempting to set up or operate the C200H Temperature Sensor Unit.**

1 Intended Audience .....	xii
2 General Precautions .....	xii
3 Safety Precautions .....	xii
4 Operating Environment Precautions .....	xii
5 Application Precautions .....	xiii

## 1 Intended Audience

This manual is intended for the following personnel, who must also have knowledge of electrical systems (an electrical engineer or the equivalent).

- Personnel in charge of installing FA systems.
- Personnel in charge of designing FA systems.
- Personnel in charge of managing FA systems and facilities.

## 2 General Precautions

The user must operate the product according to the performance specifications described in the relevant manuals.

Before using the product under conditions which are not described in the manual or applying the product to nuclear control systems, railroad systems, aviation systems, vehicles, combustion systems, medical equipment, amusement machines, safety equipment, and other systems, machines, and equipment that may have a serious influence on lives and property if used improperly, consult your OMRON representative.

Make sure that the ratings and performance characteristics of the product are sufficient for the systems, machines, and equipment, and be sure to provide the systems, machines, and equipment with double safety mechanisms.

This manual provides information for programming and operating the Unit. Be sure to read this manual before attempting to use the Unit and keep this manual close at hand for reference during operation.

 **WARNING** It is extremely important that a PC and all PC Units be used for the specified purpose and under the specified conditions, especially in applications that can directly or indirectly affect human life. You must consult with your OMRON representative before applying a PC system to the above-mentioned applications.

## 3 Safety Precautions

 **WARNING** Do not attempt to take any Unit apart while the power is being supplied. Doing so may result in electric shock.

 **WARNING** Do not touch any of the terminals or terminal blocks while the power is being supplied. Doing so may result in electric shock.

 **WARNING** Do not attempt to disassemble, repair, or modify any Units. Any attempt to do so may result in malfunction, fire, or electric shock.

## 4 Operating Environment Precautions

 **Caution** Do not operate the control system in the following locations:

- Locations subject to direct sunlight.
- Locations subject to temperatures or humidity outside the range specified in the specifications.
- Locations subject to condensation as the result of severe changes in temperature.

- Locations subject to corrosive or flammable gases.
- Locations subject to dust (especially iron dust) or salts.
- Locations subject to exposure to water, oil, or chemicals.
- Locations subject to shock or vibration.

 **Caution** Take appropriate and sufficient countermeasures when installing systems in the following locations:

- Locations subject to static electricity or other forms of noise.
- Locations subject to strong electromagnetic fields.
- Locations subject to possible exposure to radioactivity.
- Locations close to power supplies.

 **Caution** The operating environment of the PC system can have a large effect on the longevity and reliability of the system. Improper operating environments can lead to malfunction, failure, and other unforeseeable problems with the PC system. Be sure that the operating environment is within the specified conditions at installation and remains within the specified conditions during the life of the system.

## 5 Application Precautions

Observe the following precautions when using the PC system.

 **WARNING** Always heed these precautions. Failure to abide by the following precautions could lead to serious or possibly fatal injury.

- Always ground the system to 100  $\Omega$  or less when installing the Units. Not connecting to a ground of 100  $\Omega$  or less may result in electric shock.
- Always turn OFF the power supply to the PC before attempting any of the following. Not turning OFF the power supply may result in malfunction or electric shock.
  - Mounting or dismounting I/O Units, CPU Units, Memory Units, or any other Units.
  - Assembling the Units.
  - Setting DIP switches or rotary switches.
  - Connecting cables or wiring the system.
  - Connecting or disconnecting the connectors.

 **Caution** Failure to abide by the following precautions could lead to faulty operation of the PC or the system, or could damage the PC or PC Units. Always heed these precautions.

- Fail-safe measures must be taken by the customer to ensure safety in the event of incorrect, missing, or abnormal signals caused by broken signal lines, momentary power interruptions, or other causes.
- Always use the power supply voltages specified in this manual. An incorrect voltage may result in malfunction or burning.
- Take appropriate measures to ensure that the specified power with the rated voltage and frequency is supplied. Be particularly careful in places where the power supply is unstable. An incorrect power supply may result in malfunction.
- Install external breakers and take other safety measures against short-circuiting in external wiring. Insufficient safety measures against short-circuiting may result in burning.

- Do not apply voltages to the Input Units in excess of the rated input voltage. Excess voltages may result in burning.
- Do not apply voltages or connect loads to the Output Units in excess of the maximum switching capacity. Excess voltage or loads may result in burning.
- Disconnect the functional ground terminal when performing withstand voltage tests. Not disconnecting the functional ground terminal may result in burning.
- Be sure that all the mounting screws, terminal screws, and cable connector screws are tightened to the torque specified in this manual. Incorrect tightening torque may result in malfunction.
- Leave the label attached to the Unit when wiring. Removing the label may result in malfunction if foreign matter enters the Unit.
- Remove the label after the completion of wiring to ensure proper heat dissipation. Leaving the label attached may result in malfunction.
- Double-check all wiring and switch settings before turning ON the power supply. Incorrect wiring may result in burning.
- Wire correctly. Incorrect wiring may result in burning.
- Mount Units only after checking terminal blocks and connectors completely.
- Be sure that the terminal blocks, Memory Units, expansion cables, and other items with locking devices are properly locked into place. Improper locking may result in malfunction.
- Check the user program for proper execution before actually running it on the Unit. Not checking the program may result in an unexpected operation.
- Confirm that no adverse effect will occur in the system before attempting any of the following. Not doing so may result in an unexpected operation.
  - Changing the operating mode of the PC.
  - Force-setting/force-resetting any bit in memory.
  - Changing the present value of any word or any set value in memory.
- Resume operation only after transferring to the new CPU Unit the contents of the DM Area, HR Area, and other data required for resuming operation. Not doing so may result in an unexpected operation.
- Do not pull on the cables or bend the cables beyond their natural limit. Doing either of these may break the cables.
- Do not place objects on top of the cables or other wiring lines. Doing so may break the cables.
- Use crimp terminals for wiring. Do not connect bare stranded wires directly to terminals. Connection of bare stranded wires may result in burning.
- When replacing parts, be sure to confirm that the rating of a new part is correct. Not doing so may result in malfunction or burning.
- Before touching a Unit, be sure to first touch a grounded metallic object in order to discharge any static built-up. Not doing so may result in malfunction or damage.

# SECTION 1

## Hardware

The ASCII Unit is an intelligent PC peripheral device designed to make a PC-based control system more flexible and powerful. The ASCII Unit, programmed in BASIC, can be used for statistical quality control, system monitoring, data processing, report generation, and other tasks.

The ASCII Unit is a companion processor that relieves the PC of some of its housekeeping, monitoring, and decision making functions. Using BASIC, it is easy to program the ASCII Unit to process data collected by the PC and to implement decisions based on the results.

The PC is constantly monitoring all of its input lines. Individual inputs might represent counts, time intervals, temperature, position, data values, and many other parameters. Based on the values of these inputs, the PC must send the appropriate signals to the various output devices to adjust or maintain the operation of the controlled system.

The PC makes decisions based on predefined values stored permanently in its memory. For example, the PC might be programmed to monitor the temperature of a mechanical system. It continuously compares the monitored temperature with a “danger” value stored in memory. If the system temperature exceeds this value, the PC could be programmed to shut the system down until the temperature falls below a “safe” level.

The above is a very basic example. In a more complicated system, it might be necessary to process large quantities of data from many different inputs, and based on the results of mathematical, relational, and logical computations, come to a decision that the PC must take a particular course of action. With an ASCII Unit, the PC can delegate these data processing and decision making tasks. Because the ASCII Unit is programmed in BASIC instead of Ladder Diagram Programming, it is better suited for data processing tasks.

The ASCII Unit also allows the user easy access to any desired information in any BASIC format via an attached printer or display terminal.

Using the ASCII Unit for intelligent support, the PC based control system becomes a more powerful, flexible, and efficient tool.

This section describes the external hardware of the ASCII Unit. The front and back panels of the ASCII Unit contain switches, buttons, connectors, and indicators which enable the user to set up, control, and monitor ASCII Unit operations.

1-1	Front Panel . . . . .	2
1-2	Back Panel . . . . .	4
1-3	System Configuration . . . . .	7

## 1-1 Front Panel

The front panel contains two RS-232C communication ports, the programmer's START/STOP switch, a unit number selector, and several indicator LEDs. The back panel contains two sets of DIP switches for setting ASCII Unit parameters and the PC Backplane connector.

### Ports

The front panel of the ASCII Unit contains two RS-232C ports. These ports are used for connecting peripheral I/O devices to the ASCII Unit. Both ports can be used for communication devices such as printers, terminals, and modems. However, only port 1 can be used for uploading or downloading a BASIC program. The standard configuration is to connect a personal computer to port 1 and a printer or other I/O device to port 2.

### Switches

The **START/STOP** switch is a toggle switch that is used for initiating and halting execution of the ASCII Unit program.

The **Machine No.** switch is used for identifying the particular ASCII Unit. Since it is possible to have more than one ASCII Unit connected to a given PC, the Machine No. identifies each individual ASCII Unit. It is not permitted to have two ASCII Units with the same Machine No. The Machine No. can be set from 1 through 9. This should be done before power is applied to the Unit.

### Indicators





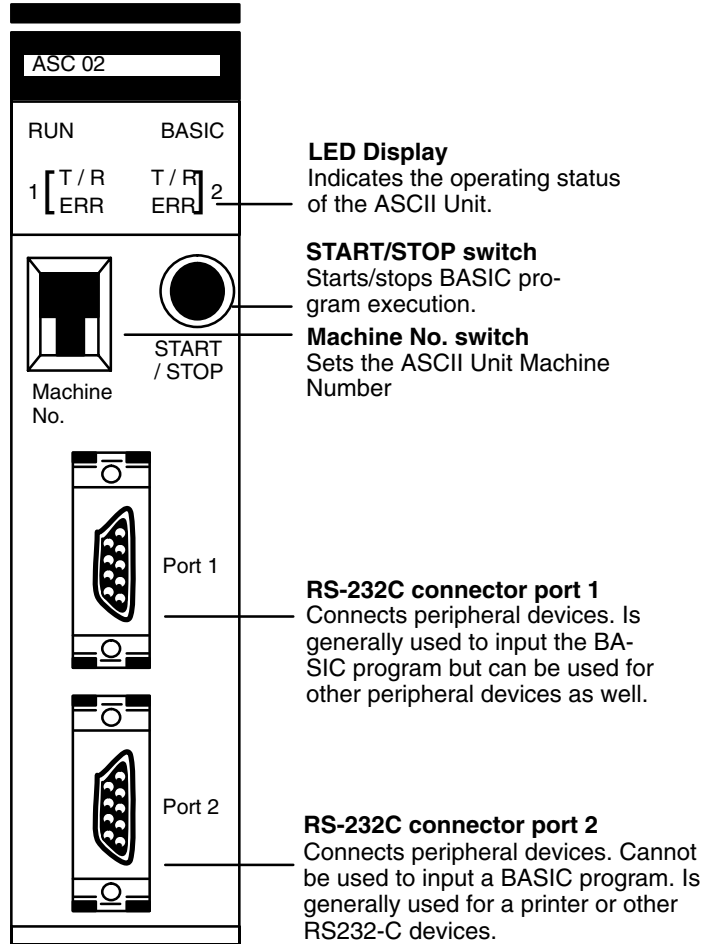

There are four indicator lights on the front panel. They are described in the table following the diagram on the next page.





Front Panel



Indicator LEDs

Name	Indication	Function
Run	 (green)	Lit when the ASCII Unit is operating normally. Unlit if an error occurs.
T/R for ports 1 and 2	 (green)	Blinks during data transmission (port 1 and port 2).
ERR 1 (error for port 1) ERR 2 (error for port 2)	 (red)	Lit if an error such as parity error occurs, or while the ASCII Unit is waiting for specific transmission conditions to be satisfied.
	 (red - 1 only)	Blinks when the battery voltage has fallen below the rated level or when the battery has not been inserted correctly.
BASIC	 (green)	Lit while the BASIC program is running.
	 (green)	Blinks when the BASIC program stops, or when the ASCII Unit is waiting for input while the BASIC program is running.
	 (green)	Unlit when in monitor mode.

Indication: Lit  Blinking  Unlit 

## **1-2 Back Panel**

This section explains the operations of the back panel of the ASCII Unit. There are two 8-pin DIP switches on the Backplane side of the ASCII Unit. The desired configuration must be set before the ASCII Unit can be plugged into the Backplane.

### **Left-Side DIP Switch Definitions**

**Pin 1** is used to select the startup mode of the ASCII Unit. The BASIC program can be automatically booted when power is applied or it can be activated after power is applied by depressing the START/STOP switch.

**Pin 2** allows automatic loading of a BASIC program from the EEPROM to the RAM when power is applied.

**Pin 3** and **Pin 4** are used to select which of the three BASIC programs will be used as the boot program.

**Pin 5** is not used.

**Pins 6, 7, and 8** are used to select the screen size of the display terminal.

The DIP switches are described in more detail in the diagram on the following page.

6: The pin numbers for port 2 corrected in the diagram. **Left-Side DIP Switch Settings**

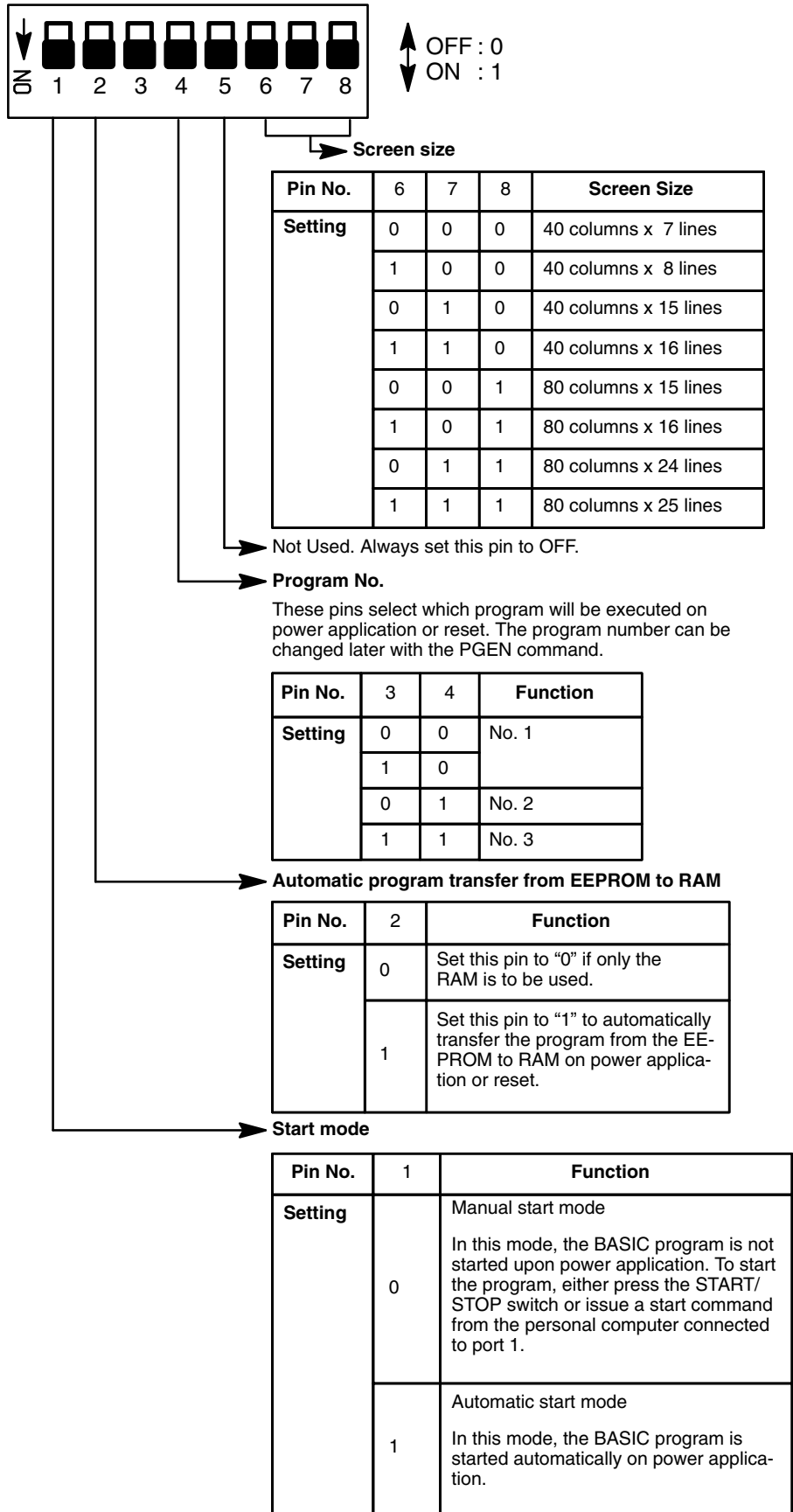

**Right-Side DIP Switch Definitions**

**Pins 1, 2, and 3** are used for setting the baud rate of port 1.

**Pin 4** is not used.

**Pins 5, 6, and 7** are used for setting the baud rate of port 2.

**Pin 8** is not used.

**Right-Side DIP Switch Settings**

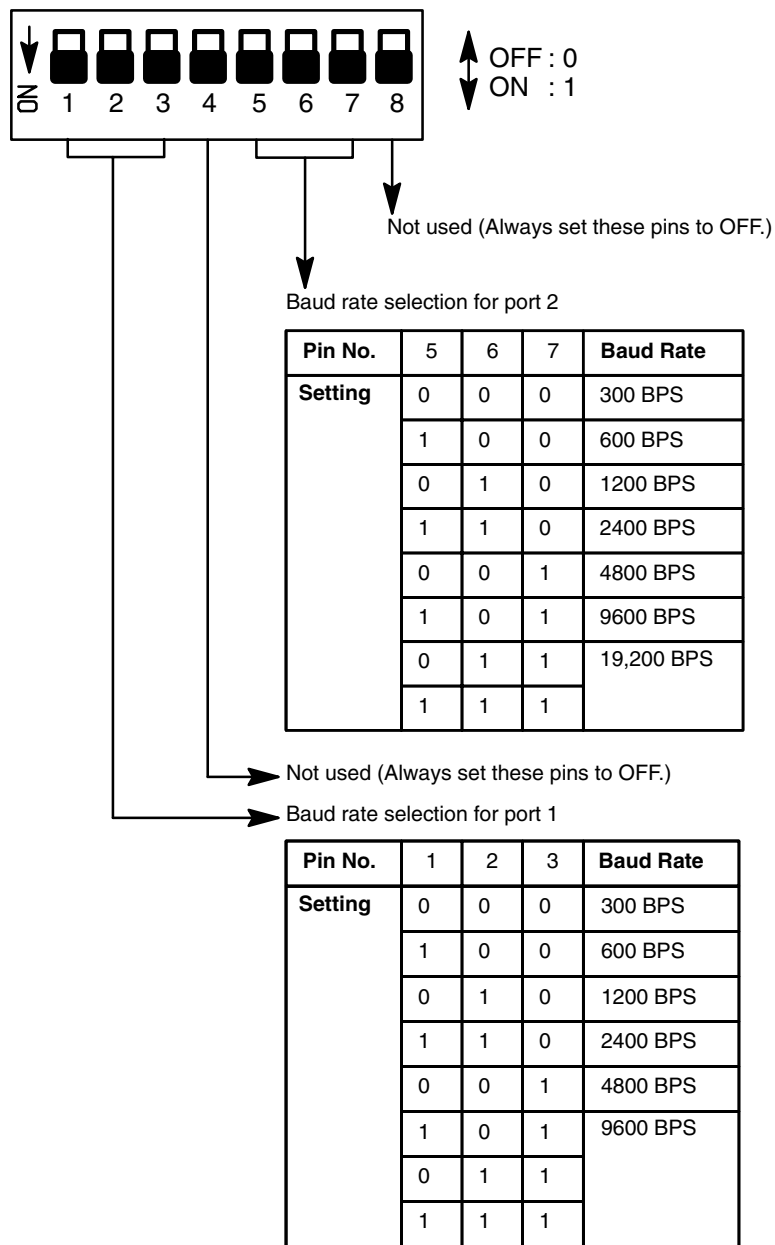

### 1-3 System Configuration

If the ASCII Unit is plugged into either of the 2 CPU Backplane slots next to the CPU Unit, it will not be possible to mount a Host Link Unit or a Programming Device, such as a Programming Console. Before mounting the ASCII Unit, the DIP switches must be set. Make sure that the power supply to the PC is turned OFF during installation of the ASCII Unit. A personal computer used for entering the BASIC program should be connected to Port 1 and other peripheral I/O devices such as a printer or a display terminal can be connected to Port 2 (refer to the following diagram). For more detailed information on peripheral interface connections and timing, refer to *Appendix B Specifications*.

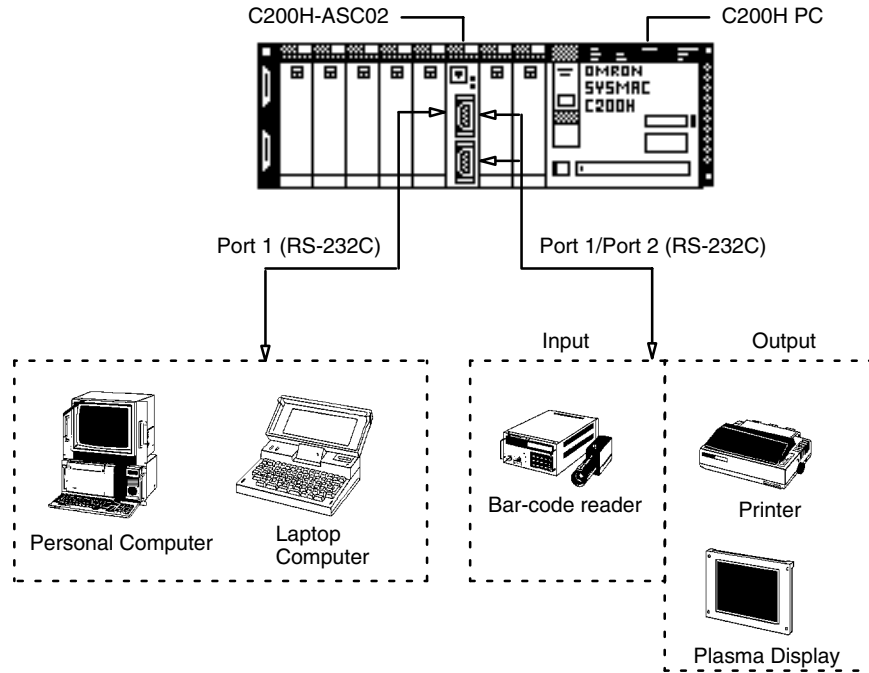



# SECTION 2

## Data Section

This section explains the data section of the PC, a special memory area used to communicate with the ASCII Unit. This section also defines several important terms which are used throughout this manual. The material in this section will become more clear later on when you begin working with an actual ASCII Unit program.

2-1	Bits and Bytes .....	10
2-2	Data Section .....	11

## 2-1 Bits and Bytes

The PC's memory is divided up into many sections, each of which has its own name and purpose. The ASCII Unit can access any of these memory areas using the BASIC READ(@) and WRITE(@) statements (this is explained in more detail in *Section 4 BASIC Language*). However, there is a special area in the PC's IR data area that is assigned to each ASCII Unit. The MACHINE NO. switch on the front panel of the ASCII Unit (refer to *Section 1-1 Front Panel*) is used to select one of the nine possible positions.

The PC's memory is organized into units called **words**. Information is usually stored in word or multiple word units. Each word has a unique address in the computer memory and can be accessed by specifying its address.

Each word contains 16 bits. A bit is the smallest piece of information that can be stored or accessed by a computer. A bit is always either one or zero. Certain bits can be accessed individually and are used as flags. A flag is usually set (1) or cleared (0) by the hardware to indicate some state of the computer or to allow or disallow certain operations. Bits can also be set or cleared by the programmer to communicate certain parameters or conditions to the CPU.

For example: the ASCII Unit program requests data to be sent from the PC using the BASIC GET statement; however, the PC has not yet collected the data. The PC's Write FLAG is cleared to zero (0), indicating that the ASCII Unit must wait. When the PC has collected the data, it sets the Write Flag to one (1), signaling the ASCII Unit that it may proceed to read the data.



## 2-2 Data Section

Each ASCII Unit is assigned four memory words called the Data Section for communication with the PC. The words are assigned from addresses 100 to 199 of the PC IR memory area. How this information is used will be understood better after you read the BASIC Language and Programming Examples sections of this manual.

See the following tables for detailed information on the location, breakdown, and purpose of each bit of the Data Section:

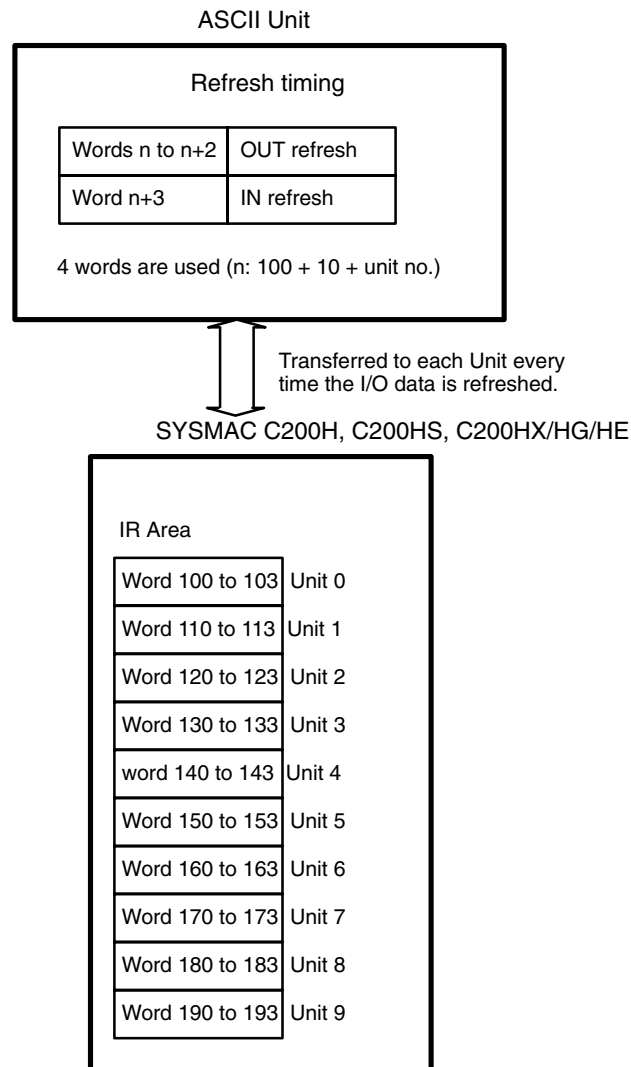

## Bit Definitions

I/O	Word No.	Bit	Name	Function
Output (n = 100 + 10 x unit no.)	n	00	---	Not used
		01	WRITE (PC to ASCII)	This bit is used as a flag. When this flag is set ("1") and the PC READ command is executed, a specified quantity of data will be transferred from the PC to the ASCII Unit, starting from a specified word. When this flag is cleared ("0"), execution of PC READ will be terminated. The interrupt numbers used by the ON PC GOSUB command become valid at the positive transition (i.e., from OFF to ON) of this flag.
		02	READ (ASCII to PC)	This bit is used as a flag. When this flag is set and the PC WRITE command is executed, a specified quantity of data will be transferred from the ASCII Unit to the PC. When this flag is cleared, execution of the PC WRITE command will be terminated.
		03	Restart	The ASCII Unit is initialized and restarted at the negative transition of this flag (i.e., from ON to OFF). When this flag is set, the ASCII Unit is initialized.
		04 to 07	Interrupt number	These four bits constitute an interrupt number that is used when the ON PC command is executed. These bits are read as a hexadecimal number; numbers 01 to 15 are treated as interrupt numbers while 00 is ignored.
		08 to 15	Output data	These bits constitute PC data. This data is written to the ASCII Unit with MOV and read from the PC with the PC GET command in the BASIC program. Note: In addition to raw data, 8-bit address data can also be transferred to the ASCII Unit to facilitate branching within the BASIC program.
	n + 1	00 to 11	Number of data words to be transferred	These bits specify the number of words to be transferred by the PC READ or PC WRITE command. The number of words may not exceed 255.
		12 to 15	---	Not used

Bit Definitions Continued

I/O	Word No.	Bit	Name	Function																													
Output (n = 100 + 10 x unit no.)	n + 2	00 to 12	Transfer base word No.	These bits specify the PC base word (the first word from which data is accessed) for data transfer.																													
		13 to 15	PC memory	<p>These bits specify the section of the PC memory from which data will be transferred between the PC and ASCII Unit with the PC READ or PC WRITE command.</p> <table border="1" style="margin-left: auto; margin-right: auto;"> <thead> <tr> <th colspan="3">Bit No.</th> <th rowspan="2">Data Area</th> </tr> <tr> <th>15</th> <th>14</th> <th>13</th> </tr> </thead> <tbody> <tr> <td>0</td> <td>0</td> <td>0</td> <td>DM Area</td> </tr> <tr> <td>0</td> <td>0</td> <td>1</td> <td>IR Area</td> </tr> <tr> <td>0</td> <td>1</td> <td>0</td> <td>HR Area</td> </tr> <tr> <td>0</td> <td>1</td> <td>1</td> <td>AR Area</td> </tr> <tr> <td>1</td> <td>0</td> <td>0</td> <td>LR Area</td> </tr> <tr> <td>1</td> <td>0</td> <td>1</td> <td>TC Area</td> </tr> </tbody> </table>	Bit No.			Data Area	15	14	13	0	0	0	DM Area	0	0	1	IR Area	0	1	0	HR Area	0	1	1	AR Area	1	0	0	LR Area	1	0
Bit No.			Data Area																														
15	14	13																															
0	0	0	DM Area																														
0	0	1	IR Area																														
0	1	0	HR Area																														
0	1	1	AR Area																														
1	0	0	LR Area																														
1	0	1	TC Area																														
Input  (n = 100 + 10 x unit no.)	n + 3	00	ASCII busy	This bit is used as a flag that is set during data transfer.																													
		01 to 03	---	Not used																													
		04	Port 1 error	This bit is used as an error flag that is set if a transmission error (such as parity error) has occurred in port 1.																													
		05	Port 2 error	This bit is used as an error flag; it is set if a transmission error (such as parity error) has occurred in port 2.																													
		06	Battery error	This bit is used as a flag that is set when the supply voltage of the built-in battery has dropped below the rated level or the battery is not correctly connected.																													
		07	BASIC RUN	This flag is set while the BASIC program is running.																													
		08	Input data	<p>These bits constitute data that is transferred from the ASCII Unit to the PC. The data is written to the PC with the ASCII Unit PC PUT command and is read by the PC with the MOV.</p> <p><b>Note:</b> In addition to raw data, 8-bit control data can also be transferred to the PC to facilitate branching within the PC program.</p>																													



# SECTION 3

## Programming and Communication

Section 3-1 explains how the ASCII Unit and the PC exchange information. Section 3-2 explains how to transfer programs from one device to another. The ASCII Unit BASIC program is written on a personal computer. To run the program, it must be transferred to the RAM of the ASCII Unit. The ASCII Unit program can be permanently stored in the ASCII Unit EEPROM and also loaded from the EEPROM. The program can also be transferred back to the personal computer or other storage device. Section 3-4 explains how to run a BASIC program once it has been transferred to the ASCII Unit.

3-1	Programs .....	16
3-2	Program Transfer .....	17
3-3	Running the BASIC Program .....	18
3-4	Assembly Routines .....	18

### 3-1 Programs

To use the ASCII Unit in conjunction with the PC, an ASCII Unit program written in BASIC is needed. A data exchange routine must also be incorporated into the PC program except when the READ(@...) and WRITE(@...) statements are used with specific memory area designators. The PC data exchange routine must set the number of words to be transferred, the base address, and the specific memory area. This can be done using the PC MOV instruction.

There are two ways the ASCII Unit can communicate with the PC. In the first method, the PC controls the timing of the data transfer between the two devices. The ASCII Unit “requests” access to the PC data memory area using the PC READ, PC WRITE, PC GET, or PC PUT statements, and then waits for the PC to respond by setting either the read or write flag. The PC data exchange routine performs the designated operations. When the PC is ready, the appropriate flag is set and the ASCII Unit proceeds with the data transfer.

In the second method, no special PC data exchange code is necessary to facilitate communication between the two devices. If the memory area designator parameter is specified with the PC READ or PC WRITE statement, the ASCII Unit can directly access the specified PC memory area.

The following two figures illustrate the relationship between the PC program and the ASCII Unit program.

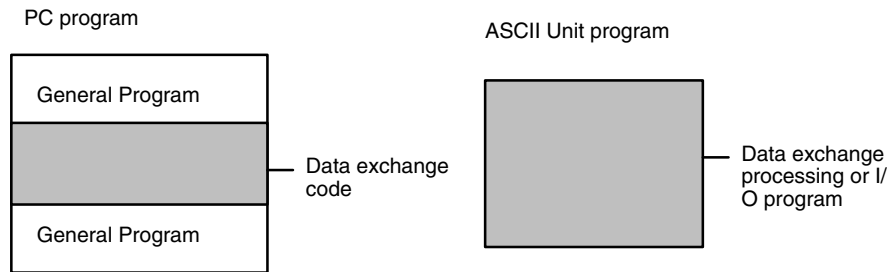

**This diagram illustrates the relationship between the PC data exchange code and the ASCII Unit program.**

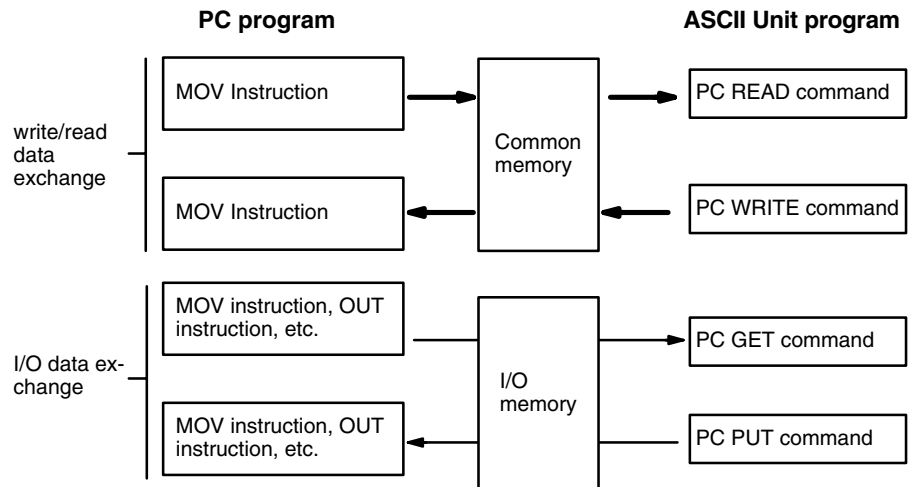

## 3-2 Program Transfer

### Preparation

For the personal computer to communicate with the ASCII Unit, set the computer communication software as follows:

Baud rate: same as ASCII Unit  
Data length: 8 bits  
Parity: none  
No. stop bits: 2

Also: Full duplex, no echo, no XON/XOFF buffer busy control, no auto line feed.

Set the ASCII Unit DIP switches to the desired configuration.  
(Refer to Section 1 for DIP switch settings.)

### Transfer

The ASCII Unit BASIC program must be written on a personal computer which is connected to port 1 of the ASCII Unit through an RS-232C interface. A program can be transferred to the ASCII Unit from the personal computer or any other storage device connected to one of the communication ports with the BASIC LOAD command (refer to *Section 4-2-2 Commands*). Programs can also be transferred from the ASCII Unit's EEPROM to the ASCII Unit's RAM using the LOAD command.

Programs can be transferred from the ASCII Unit's RAM to the EEPROM or to a personal computer or other storage device connected to one of the communication ports using the BASIC SAVE command (refer to *Section 4-2-2 Commands*).

The ASCII Unit can be booted on power application by a program stored in the EEPROM. To do this, set pin 2 of the left-side DIP switch on the back panel of the ASCII Unit to ON (refer to *Section 1-2 Back Panel*).

During data transfer, an overflow may occur if the buffering capacity of the baud rate settings of the computer and the ASCII Unit are not matched. If an overflow error does occur, set either a slower baud rate or specify XON with the OPEN command.

**Note** The EEPROM's guaranteed lifetime is 5000 write operations.

Direction of Data Transfer

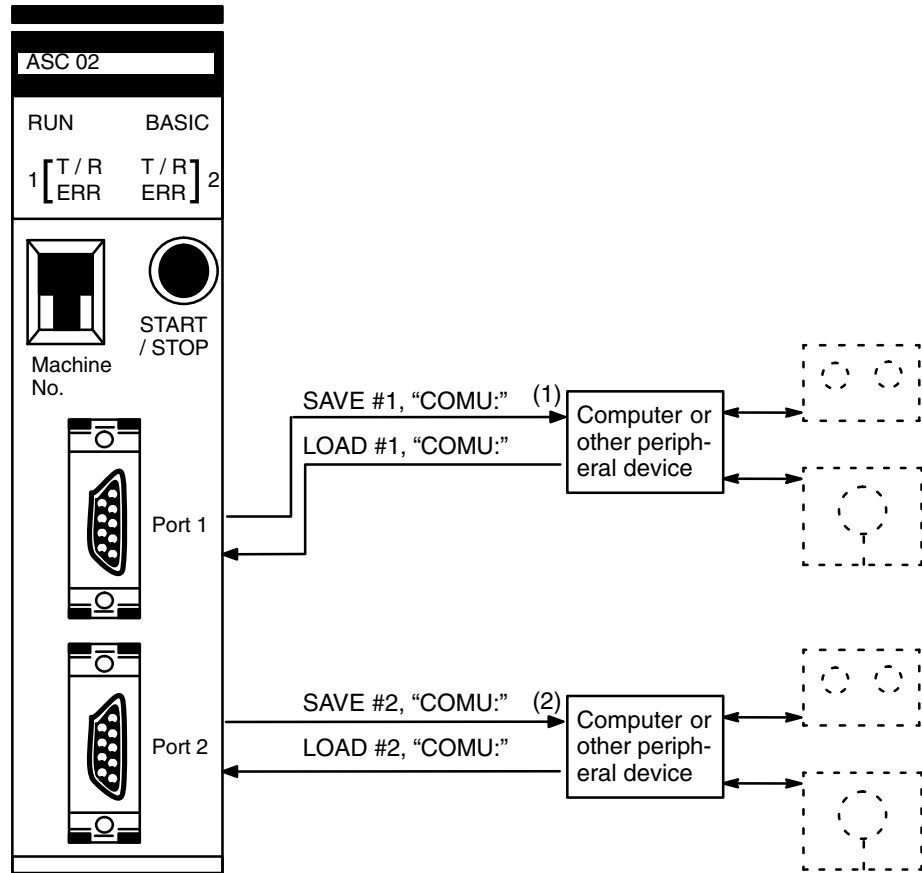

**Note** Refer to the explanation of the OPEN command in *Section 4-2-4 Device Control Statements* for details on COMU.

### 3-3 Running the BASIC Program

The ASCII Unit can store and access three separate BASIC programs. Each program has an associated program number. The user can specify which program is to be used by setting a DIP switch on the back panel of the ASCII Unit. This must be done before the Unit is activated.

There are three ways to execute the specified BASIC program:

- 1, 2, 3... 1. Enter the RUN command from the keyboard of the personal computer. (Keying in CTRL+X will abort the program.)
2. Pressing the START/STOP switch on the ASCII Unit will start the program. Pressing it again will stop the program.
3. If pin 1 of the left-side DIP switch is set to the ON position, the specified program will be executed automatically when the Unit is turned ON or when it is reset.

### 3-4 Assembly Routines

Assembly language routines can be written for the ASCII Unit and called from the BASIC program with the USR statement. An assembly program can be saved to the personal computer with the S command and loaded from the personal computer with the L command (refer to *Section 5-3 Monitor Mode Commands*). Assembly programs are stored in the S format.



# SECTION 4

## BASIC Language

This section contains an explanation of the terminology, components, structure, and use of the BASIC programming language on the ASCII Unit. Even those familiar with BASIC should study this section carefully, as many of the ASCII Unit BASIC commands, statements, and functions are non-standard, especially those that control I/O operations. Experienced BASIC users may wish to skip Section 4-1 and move directly to Section 4-2. All readers should pay special attention to the explanation of statements that are prefixed with "PC." Also pay special attention to the OPEN statement.

4-1	Program Configuration .....	20
4-2	BASIC Language .....	25
4-2-1	BASIC Format .....	25
4-2-2	Commands .....	26
4-2-3	General Statements .....	32
4-2-4	Device Control Statements .....	51
4-2-5	Arithmetic Operation Functions .....	54
4-2-6	Character String Functions .....	57
4-2-7	Special Functions .....	60

# 4-1 Program Configuration

A BASIC program consists of commands, statements, and functions.

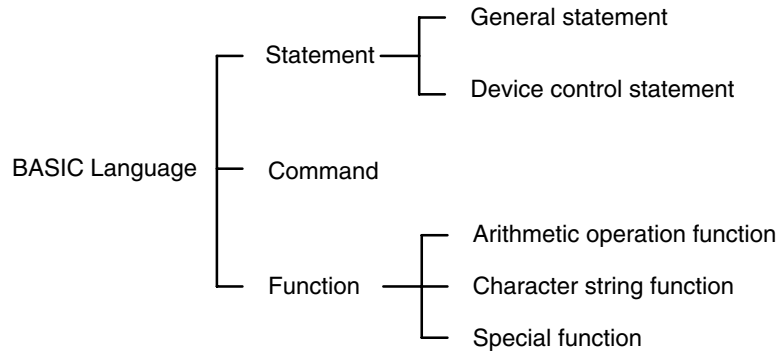

**Basic Statements** designate and control the flow of programs and are generally used in program lines within a program.

**Basic Commands** are usually entered from the command line and control operations external to the program such as printing and listing.

Examples: print, list, run

**Functions** are self-contained programs which accept one or more arguments, perform predefined calculations, and return a result/s. There are predefined BASIC functions for arithmetic and string operations as well as user-defined functions.

Examples: INT(x), LOG(x), SQR(x)

## Lines and Statements

A program written in BASIC is a series of lines, each of which consists of one or more statements. If several statement are written on the same line, they must be separated with colons(:). A line can be no longer than 255 characters. Use single quotation marks (') to separate comments.

Example of four statements on a line:

```
10 FOR L=1 TO 100: J=L*I: PRINT J: NEXT L
```

## Line Numbers

Every BASIC program line begins with a line number. Line numbers indicate the order in which the program lines are stored in memory and are also used as references for branching and editing. Line numbers must be in the range of 0 through 63999. A period may be used in AUTO, DELETE, EDIT, and LIST commands to refer to the current line.

Examples:

```
LIST. EDIT. AUTO DEL 100-
```

## Character Set

The BASIC character set comprises alphabetical characters, numeric characters, and special characters.

The alphabetic characters in BASIC are the upper case and lower case letters of the alphabet. The numeric characters in BASIC are the digits 0 through 9.

The following special characters are recognized by BASIC:

```
SP (space) ! " # $ % & ' ( ) * + , - . / : ; < = > ? [ \ ] ^ _
```

## Constants

The following can be used as constants:

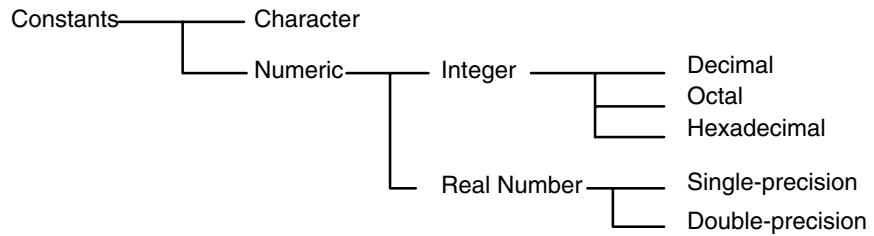

**Character Constants**

A character constant is a character string enclosed by double quotation marks ("). It can be up to 255 characters long. If it has no character, it is called an "empty character string" or a null string.

Example: "CF-BASIC"

**Integer Constants**

Whole numbers between -32768 and 32767 can be used. An optional percent sign (%) can be added to specifically indicate an integer constant. Integer constants do not have decimal points.

Examples: 1234 -1234 12

**Octal Constants**

Octal numbers 0 through 7 beginning with the prefix "&" and within the range of &0 to &177777 can be used.

Examples: &0127 &7777

**Hexadecimal Constants**

Hexadecimal numbers with the prefix "&H", from 0 to F (0 to 9,A,B,C,D,E,F) and in the range &H0000 to &HFFFF can be used.

Examples: &H5E &HBF4

**Floating Point Constants**

Single precision: This type of constant is stored with seven-digit precision and is output as a six-digit constant with the seventh digit rounded off. It is represented by one of the following methods:

- 1, 2, 3... 1. As a number with seven or less digits: 1234.5
- 2. As a number in exponential form using E: 1.2E+3
- 3. As a number with the character "!" at the end: 2.34!

Double precision: This type of constant is stored with 16-digit precision and is output as 16 digits or less. It is represented by one of the following methods:

- 1, 2, 3... 1. As a number with 8 or more valid digits: 1.23456789
- 2. As a number in exponential form using D: -1.2D-3
- 3. As a number with the character "#" at the end: 2.34#

**Variables**

Variables are names used to represent values that are used in a BASIC program. The value of a variable may be assigned as the result of calculations or explicitly by the programmer with an assignment statement. If no value is assigned to a numeric variable, it is assumed to be zero. If no value is assigned to a character variable, it is assumed to be a null string.

**Variable Name**

A variable may be up to 255 alphanumeric characters long, but only the first 16 characters are actually valid. No variable can start with "FN" or a valid BASIC command name.

If a parameter begins with a reserved word, syntax error will occur. TOTAL and ABSOL, for example, cannot be used because they include reserved words TO and ABS. Syntax errors will result if these parameters are used.

**Type Declarator**

The variable TYPE must be declared. This is done using a type declarator which is placed after the variable name. Even if two variables have the same name, they will be treated differently if they are declared as different types of variables.

Integer: Uses 2 bytes per variable.

! Single-precision real: Uses 4 bytes per variable.

# Double-precision real: Uses 8 bytes per variable.

\$ Character: Uses a maximum of 255 characters.

There is a second way to declare variable types. The BASIC statements DEFINT, DEFSTR, DEFSNG, and DEFDBL may be used to declare the types for certain variable names.

### Variable Array

An array is a group of values of the same TYPE that is stored and referenced as a unit by the same variable name. Each element in an array has a unique position and is referenced by the name of the array subscripted with an integer or integer expression.

There can be many dimensions to an array. The most common types are one, two, and three dimensional arrays. An array has one subscript for each dimension in the array.

For example, T(4) would reference the fourth element in the one-dimensional array T. R(2,3) would reference the value located in the second row and third column of the two-dimensional array R.

The maximum number of dimensions of an array is 255. The maximum number of elements per dimension is 32767. The array size and number of dimensions must be declared with the DIM statement. The subscript value zero is the position of the first element in an array. All elements of an array must be of the same TYPE.

### Type Conversion

When necessary, BASIC will convert a numeric constant from one TYPE to another. The following rules and examples apply:

- 1, 2, 3... 1. If the numeric data on the right side of an assignment statement differs from the type of data on the left side, the right side is converted to match the left. However, character data cannot be converted to numerical data, or vice versa.  
Example: A = 12.3: if A is an integer, then "12" is assigned to A.
2. Double-precision data is converted to single-precision data when assigned to a single-precision variable.  
Example:  
IF "A" is a single-precision variable and the statement:  
LET A = 12.3456789# occurs in a program, then 12.3456789# will be converted to a single-precision number and then assigned to "A."
3. When an arithmetic operation is performed using both single-precision and double-precision values, the single-precision value is converted to double-precision first, and then the operation is performed. Therefore, the result is a double-precision value.  
Example: 10#/3 (double-precision)
4. In logic operations, all numeric data is first converted into integer data. If any value cannot be converted into an integer within the range of -32768 to 32767, an error will occur.  
Example: LET A = NOT 12.34, -13 is assigned as A.
5. When a real number is converted into an integer, everything to the right of the decimal point is rounded off.

Example: A = 12.3: "12" is assigned to A.

**Expressions**

Expressions refer to constants, variables, and functions that have been combined by operators. Numeric values, variables, or characters alone can also form expressions. There are four types of expressions:

- Arithmetic
- Relational
- Logical
- Character

Of these, the first three produce numeric values as a result and are thus called "numeric expressions". The last type is called a "character expression."

**Arithmetic Operators**

An arithmetic expression is made up of constants, variables, and functions combined using arithmetic operators. A list of valid arithmetic operators is shown in the following table.

Arithmetic Operator	Example	Operation
+	A + B	Addition
-	A - B, -A	Subtraction or negation
*	A * B	Multiplication
/	A / B	Real number division
\	A \ B	Integer division
MOD	A MOD B	Remainder after integer division
^	A ^ B	Exponentiation

Remarks:

If A or B is a real number in an expression using the \ or MOD operator, the decimal part is first rounded up to convert the real number into an integer, and then the operation is performed.

**Relational Operators**

Relational operators compare two values. The output is "-1" (&HFFFF) if the two values are equal and "0" if they are not.

Relational Operator	Example	Operation
=	A = B	Equal
<>, ><	A <> B	Not equal
<	A < B	Less than
>	A > B	Greater than
≤	A ≤ B	Less than or equal to
≥	A ≥ B	Greater than or equal to

**Character Operator**

A character expression is made up of character constants and variables that are linked with the character operator "+". Instead of adding characters together, the "+" operator links the characters together to form one character value.

Input: A\$="CF" B\$="BASIC" PRINT A\$+"-"+B\$

Output: "CF-BASIC" is displayed.

**Logical Operators**

Logical Operators perform tests on multiple relations, bit manipulation, or Boolean operations. The logical operator returns a bitwise result which is either "true" (not 0) or "false" (0). In an expression, logical operations are per-

formed after arithmetic and relational operations. The outcome of a logical operation is determined as shown in the following table. The operators are listed in the order of precedence.

Logical Operator	Description, Example, and Result	
NOT (negation)	A	NOT A
	1	0
	0	1
AND (logical product)	A B	A AND B
	1 1	1
	1 0	0
	0 1	0
	0 0	0
OR (logical sum)	A B	A OR B
	1 1	1
	1 0	1
	0 1	1
	0 0	0
XOR (exclusive-OR)	A B	A XOR B
	1 1	0
	1 0	1
	0 1	1
	0 0	0
IMP (implication)	A B	A IMP B
	1 1	1
	1 0	0
	0 1	1
	0 0	1
EQV (equivalence)	A B	A EQV B
	1 1	1
	1 0	0
	0 1	0
	0 0	1

**Operator Priority**

Arithmetic and logical operations are performed in the following order. Note, however, that an expression or function enclosed by parentheses is executed first, irrespective of operator priority.

1. ^ (exponentiation)
2. - (negation)
3. \*, /
4. \
5. MOD
6. +, -
7. Relational operators
8. NOT
9. AND
10. OR
11. XOR
12. IMP
13. EQV

Calculation Examples of Logical Expressions

**NOT** (negation)

A = 1 = 0000000000000001

NOT 1 = 1111111111111110 = -2

NOT A = -2

**AND** (logical product)

A = 5 = 000000000000101

B = 6 = 000000000000110

A AND B = 000000000000100 = 4

**OR** (logical sum)

A = 4 = 000000000000100

B = 3 = 000000000000011

A OR B = 000000000000111 = 7

**XOR** (exclusive OR)

A = -4 = 111111111111100

B = 5 = 000000000000101

A XOR B = 111111111111001 = -7

**EQV** (equivalent)

A = -4 = 111111111111100

B = 5 = 000000000000101

A EQV B = 000000000000110 = 6

**IMP** (implication)

A = -4 = 111111111111100

B = 5 = 000000000000101

A IMP B = 000000000000111 = 7

## 4-2 BASIC Language

This section explains, in detail, the BASIC commands, statements, and functions. They are presented in alphabetical order by section. Each description is formatted as described in the following section.

### 4-2-1 BASIC Format

Purpose: Explains the purpose or use of the instruction

Format: Shows the correct format for the instruction

The following rules apply to the format descriptions of all commands, instructions, and functions:

- Items in CAPITAL LETTERS must be input as shown.
- Items in lower case letters enclosed in angle brackets (< >) are to be supplied by the user.
- Items in square brackets ([ ]) are optional.
- All punctuation marks except angle and square brackets (i.e., commas, hyphens, semicolons, parentheses, and equal signs) must be included where shown.
- Arguments to functions are always enclosed in parentheses. In the formats given for the functions in this chapter, the arguments have been abbreviated as follows:

x and y : represent numeric expressions

I and J : represent integer expressions

A\$ and B\$ : represent string expressions

Remarks: Explain in detail how to use the instruction.

Examples: Show sample code to demonstrate the use of the instruction.

Notes: Explain additional pertinent information.

## 4-2-2 Commands

This section describes all of the BASIC commands for the ASCII Unit.

### AUTO Command

Purpose: To automatically generate line numbers for each line of the program

Format: AUTO [<line>][,<increment>]

<line> is an integer from 0 to 63999.

<increment> is an integer value that specifies the increment of the generated line numbers.

Examples: AUTO 100, 10

AUTO 500, 100

Remarks:

Auto begins numbering at <line> and increments each subsequent line number by <increment>. The default value for both <line> and <increment> is 10.

The AUTO Command can be canceled by entering CTRL+X.

If an already existing line number is specified, an asterisk (\*) is displayed immediately after the line number. If a new line number is input followed by a CR key, the new line number will be used instead. Pressing only the CR key leaves the line number unchanged.

### CONT Command

Purpose: To resume execution of a program after a Ctrl+X has been typed, a STOP or END statement has been executed, or an error has occurred

Format: CONT

Remarks:

Execution resumes at the point where the break occurred. If CTRL+X is pressed during data exchange with an external device, execution is aborted and the program cannot be resumed.

If the program is modified after execution has been stopped, the program cannot be resumed.

CONT is usually used in conjunction with STOP for debugging.

### DEL Command

Purpose: To Delete the specified program lines

Format: DEL [<first>] [-<last>] or DEL <first> -

<first> is the first line number deleted.

<last> is the last line number deleted.

Examples:

DEL 100           Deletes line 100



DEL 100-       Deletes all lines from line 100  
 DEL -150       Deletes all lines up to line 150  
 DEL 100-150   Deletes all lines between 100 and 150

Remarks:

A period may be used in place of the line number to indicate the current line.

**EDIT Command**

Purpose:   To Edit one line of the program

Format:   EDIT <line>

<line> is the line number to be edited.

Remarks:

The EDIT Command is used to display a specified line and to position the cursor at the beginning of that line. The cursor can then be moved within the specified line and characters can be inserted or deleted. Executing "EDIT ." will bring up the previously entered program line. "." refers to the last line referenced by an EDIT statement, LIST statement, or error message.

**LIST Command**

Purpose:   To list the program currently in memory on the screen or other specified device

Format:   LIST [<line>] [-<line>]]

LLIST [<line>] [-<line>]]

<line> is a valid line number from 0 to 63339.

Remarks:

LIST displays a program or a range of lines on the screen or other specified device.

If the line range is omitted, the entire program is listed. "LIST." displays or prints the line that was last input or was last displayed.

Output can be aborted by entering CTRL+B or CTRL+X. If CTRL+B is used, listing can be resumed by entering CTRL+B again.

LIST/LLIST Commands can be written into the program, but the following statement will not be executed and the ASCII Unit will enter command input wait status.

The LIST Command automatically outputs to port 1 and the LLIST Command automatically outputs to port 2.

The LLIST Command outputs data to the device "LPRT" independently of the OPEN statement.

When the dash (-) is used in a line range, three options are available:

- 1, 2, 3...**
1. If only the first number is given, that line and all higher numbered lines are listed.
  2. If only the second number is given, all lines from the beginning of the program through the given line are listed.
  3. If both numbers are given, the inclusive range is listed.

Examples:

LIST -500       List everything up to line 500

LIST 10-100    List all lines ranging from 10 through 100

LIST 200- List everything from line 200 on

### LOAD Command

Purpose: To load a program from the EPROM into memory

Format: LOAD

Remarks:

The contents of the program area specified with the MSET Command are loaded from the EEPROM.

Purpose: To load a program sent from an RS-232C device to the current program area

Format: LOAD #<port>,"COMU:[<spec>,<vsl>]

<port> is either port 1 or port 2.

<spec>: see OPEN statement tables.

<vsl>: valid signal line--refer to the OPEN statement tables.

Example: LOAD #1,"COMU:(43)

Remarks:

When this command is executed, the BASIC indicator LED will begin blinking rapidly. Make sure the RS-232C device is connected at this time.

During execution of the LOAD command, the START/STOP switch and key input from port 1 will not be acknowledged.

The program area currently used is cleared immediately after the LOAD command is executed.

For details on communication parameters, valid signal lines, and COMU, refer to the OPEN instruction.

### MON Command

Purpose: To change to monitor mode

Format: MON

Remarks:

This Command passes control from BASIC mode to monitor mode (refer to Section 5 for details on monitor mode).

To return to BASIC mode, enter CTRL+B.

### MSET Command

Purpose: To reserve memory space for an assembly program

Format: MSET [<address>]

<address> is a hexadecimal number between &H200 and &H7FFF.

Example: MSET &H5000

Remarks:

When an assembly program is to be used in conjunction with a BASIC program, special memory space must be reserved for the assembly program.

The MSET command sets the lowest possible address that a BASIC program can occupy. The assembly program is then stored "below" the BASIC program in memory. It is necessary to reserve enough space for the assembly program to "fit".

If no MSET address is specified, the default MSET boundary address will be set at &H2000. Do not specify an address higher than &H7FFF or the system stack will be overwritten.

The address specified by this command is maintained even if system power is turned OFF. To cancel the effect of this command, execute MSET &H2000.

This diagram illustrates the PC memory map before and after the MSET command is executed.

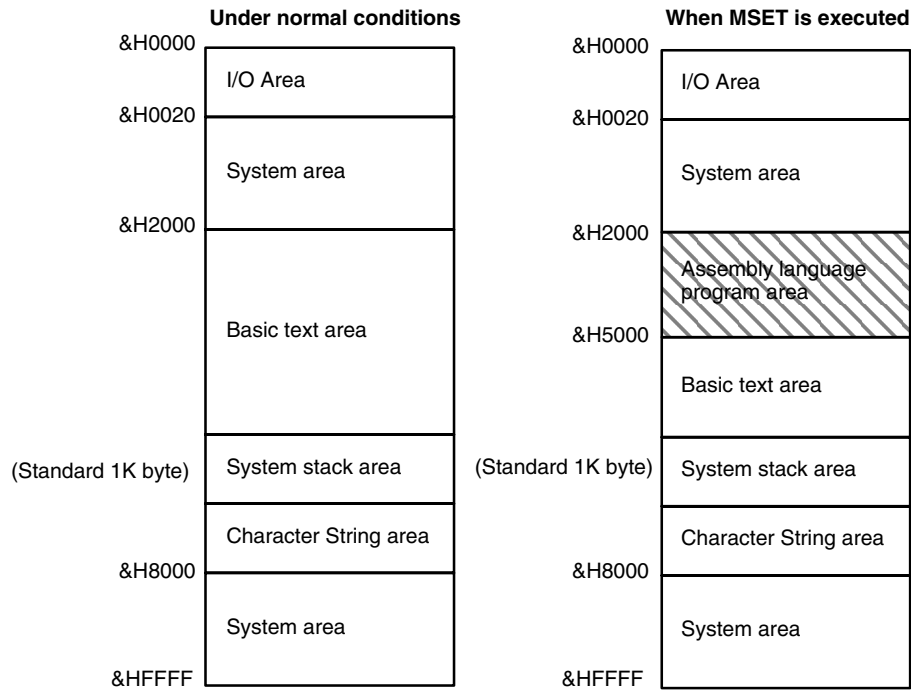

**NEW Command**

Purpose: To delete the program currently in memory and clear all variables

Format: NEW

Remarks:

New is used to clear memory before a new program is entered. New causes all files and ports to be closed.

Programs named with the PNAME command cannot be erased. The name must therefore be erased first by executing PNAME " " before the NEW command is executed.

**PGEN Command**

Purpose: To select one of three program areas for the current program

Format: PGEN <num>

<num> is an integer of value 1, 2, or 3.

Remarks:

The occupied capacity of the selected program area will be displayed. (Refer to the discussion of the PINF command.)

**PINF Command**

Purpose: To display memory area information

Format: PINF [<arg>]

<arg> is either an integer of value 1, 2, or 3 or the character string "ALL". ALL is entered without quotation marks.

Examples: PINF 1

PINF ALL

Remarks:

This Command displays the amount of program area currently being used and the program names that have been assigned by the PNAME command. Specify 1, 2, or 3 as <arg> for a specific program area.

If <arg> is not specified, information on the area currently being used is displayed.

If ALL is specified, information on all three program areas will be displayed.

### **PNAME Command**

Purpose: To assign a name to a program stored in the area specified with the PGEN command or to cancel a previously assigned program name

Format: PNAME <string>

<string> is the chosen name (enclosed in quotes) for the program or the null string, "".

Examples: PNAME "PROG1"

PNAME ""

Remarks:

The chosen name must be eight characters or less.

Program areas assigned a name with the PNAME command are protected from execution of the LOAD and NEW commands which erase program area contents. It is necessary to erase all assigned program names with the PNAME "" command before execution of the LOAD or NEW commands.

### **RENUM Command**

Purpose: To renumber program lines

Format: RENUM [<new number>] [, [<old number>] [, <inc>]]

<new number> is the first line number to be used in the new sequence. The default is 10.

<old number> is the line in the current program where the renumbering is to begin. The default is the first line of the program.

<inc> is the increment to be used in the new sequence. The default is 10.

Examples: RENUM 200

RENUM 500, 200, 10

Remarks:

RENUM will also change all line number references following GOTO, GO-SUB, THEN, ELSE, ON ... GOTO, ON ... GOSUB, RESTORE, RENAME, and ERL statements to reflect the new line numbers.

Statement numbers greater than 63999 cannot be used.

### **RUN Command**

Purpose: To execute a program

Format: RUN [<line>]

<line> is any line number less than 63999.

Remarks:

If a line number is specified, execution begins from that line. If the line number is omitted, execution starts from the first line of the program.

The RUN command clears all variables and closes all open files before executing the designated program.

Program execution can be aborted with CTRL+X, or the START/STOP switch. Program execution can also be aborted from within the program by an END or STOP statement.

### SAVE Command

Purpose: To write the program area to the EEPROM

Format: SAVE

Remarks:

The contents of the BASIC program area and the assembly language program area reserved with the MSET command are written to the EEPROM.

If the START/STOP switch is pressed during execution of the SAVE command, the process will be aborted.

Purpose: To write a program in the current program area to a storage device connected to one of the ports.

Format: SAVE #<port>,"COMU:[(<valid signal line>)]"

<port> is one of the two ports (1,2).

<valid signal line>: refer to the OPEN statement tables.

Example: SAVE #1,"COMU:(43)"

Remarks:

When this command is executed, the BASIC LED indicator on the ASCII Unit will blink rapidly warning the user to prepare the peripheral device for data transfer. When the device is set, press the START/STOP switch.

During execution of this command the START/STOP switch and key input through port 1 are inhibited.

For further details on COMU refer to the OPEN command.

### TRON and TROFF Commands

Purpose: To trace execution of a program

Format: TRON

Remarks:

The TRON command is a debugging tool that enables the programmer to follow the execution of a program line by line. Execution of the TRON command will cause the line numbers of subsequent program statements to be displayed on the screen as they are executed.

The trace can be canceled with the TROFF command, the NEW command, by turning off the power or with the RESET switch.

### VERIFY Command

Purpose: To verify the contents of the EEPROM by comparing them to the contents of the program area

Format:     VERIFY

Remarks:

If the contents of the program area are identical to those of the EEPROM, the message "READY" will be displayed; otherwise, the message "PROM ERROR" is displayed.

## 4-2-3     General Statements

### CLEAR Statement

Purpose:     To initialize numeric and character variables and set the size of the character memory area

Example:    CLEAR [<size>]

<size> is the size of memory area used to process character strings and is specified in byte units.

Remarks:

This command initializes numeric variables to zero and character strings to empty. It also clears all user functions defined by the DEF FN statement.

This statement must be executed before the ON ERROR GOTO statement.

<size> is automatically set to 200 bytes upon power application or after reset.

### COM Statement

Purpose:     To enable, disable, or stop an interrupt defined by the ON COM GOSUB statement.

Format:     COM[<port number>] ON/OFF/STOP

<port number> is an integer (1 or 2).

Example:    COM1 ON

Remarks:

The COM ON statement enables an interrupt defined by the ON COM GOSUB statement.

After this statement has been executed, an interrupt will be generated each time data is written to the specified port buffer. The interrupt will cause program execution to branch to a routine defined by the associated ON COM GOSUB statement.

The COM OFF statement disables the com port interrupts. Even if data is written to a com port buffer, branching will not take place.

The COM STOP statement stops the com port interrupts from branching program execution. However, if the COM ON statement is subsequently executed, branching to the specified interrupt service routine based on the "STOPPED" interrupt will then take place.

If no port number is specified, port 1 is selected as the default port.

Execute the COM OFF statement at the end of the program.

The COM ON/OFF/STOP statement can be executed only after the ON COM GOSUB statement has been executed.

Program Example:

```

10  OPEN #2, "COMU:"
20  ON COM2 GOSUB 100
30  COM2 ON

```

```

40 GOTO 40
100 IF LOC(2)<>0 THEN A$=INPUT$ (LOC(2), #2)
110 RETURN

```

**DATA Statement**

Purpose: Defines numeric and character constants to be specified in a subsequent READ statement

Format: DATA <constant>[,<constant>]...

<constant> may be a numeric constant in any format; i.e., fixed-point, floating-point, or integer. <constant> can also be a character string. Quotation marks are necessary only if the constant contains comas, colons, or spaces.

Example: DATA CF, 10, 2.5, "A.:B"

Remarks:

Any number of DATA statements can be used in a program. READ statements access DATA statements in order (by line number). The data contained therein may be thought of as one continuous list of items, regardless of how many items are on a line or where the lines are placed in the program.

DATA statements are non-executable and can be placed anywhere in a program. A data statement can contain as many constants as will fit on one line (separated by comas).

The variable type given in the READ statement must agree with the corresponding constant in the DATA statement.

DATA statements may be reread from the beginning by use of the RESTORE statement.

No comment (with ":" or "") can be written after the DATA statement.

**DEF FN statement**

Purpose: To define and name a function written by the user

Format: DEF FN<name>[(<arg1>[,<arg2>]...)] = <def>

<name>, which must be a legal variable name, is the name of the function.

<argn> is a list of variable names called parameters that will be replaced with values calculated when the function is called. The items in the list are separated by comas.

<def> is an expression that performs the operation of the function and is limited to one line.

Example: DEF FNA (X, Y, Z) = SQR(X^2 + Y^2 + Z^2)

Remarks:

A user function must be defined with the DEF FN statement before it can be called. To call a user function once it has been defined, append FN to the assigned name of the function and set it equal to some variable.

distance = FNA(X,5,5)

Variable names that appear in the defining expression serve only to define the function; they do not affect program variables that have the same name.

The variables in the parameter list represent, on a one-to-one basis, the argument variables or values that will be given in the function call.

This statement may define either numeric or string functions. If a type is specified in the function name, the value of the expression is forced to that type before it is returned to the calling statement.

If a type is specified in the function name and the argument type does not match, an error will occur.

### DEF/INT/SNG/DBL/STR Statement

**Purpose:** To declare variable types as integer, single-precision, double-precision, or string

**Format:** DEF <type><letter>[-<letter>]  
 [<letter>[-<letter>]]...  
 <type> is INT, SNG, DBL, or STR

**Remarks:**

Any variable names beginning with the <letter(s)> listed will automatically be assigned to the specified variable type.

The “”, “!”, and “\$” declaration characters take precedence over a DEF <type> statement.

If no type declaration statements are encountered, BASIC assumes all variables without declaration characters to be single-precision variables.

**Example:** DEFINT A-D, X

All variables beginning with A, B, C, D, and X will be integer variables.

### DEF USER Statement

**Purpose:** To specify the starting address of an assembly language subroutine that will be called via the USR function

**Format:** DEF USR [<digit>] = <offset>  
 <digit> is an integer from 0 to 9. The digit corresponds to the USR routine number whose address is being specified. If <digit> is omitted, DEF USR0 is assumed.  
 <offset> is the starting address of the USR routine.

**Remarks:**

Any number of DEF USR statements may appear in a program to redefine subroutine starting addresses, thus allowing access to as many subroutines as necessary.

**Program Example:**

```
100 DEF USR1=&H2100
110 POKE &H2100, &H39
120 A=USR1 (A)
130 PRINT A
```

### DIM Statement

**Purpose:** To specify the maximum values for array variable subscripts and allocate storage accordingly

**Format:** DIM <variable>(<subscripts>)  
 [ ,<variable>(<subscripts>)]...  
 <variable> is a legal variable name.



<subscripts> are the maximum number of elements for each dimension of the array. There can be up to 255 subscripts but the maximum size of the array cannot exceed the amount of memory available.

Example: DIM A (10,20), B\$(30)

Remarks:

If an array variable name is used without a DIM statement, the maximum value of the array's subscript(s) is assumed to be 10. If a subscript is used that is greater than the maximum specified, an error will occur. The minimum value for a subscript is zero.

The DIM statement initializes all the elements of numeric arrays to zero. String array elements are initialized to NULL.

### END Statement

Purpose: To terminate program execution, close all files, and return to command level

Format: END

Remarks:

END statements may be placed anywhere in the program to terminate execution. Unlike the STOP statement, END closes all open files or devices. An END statement at the end of the program is optional. BASIC always returns to command level after an END is executed.

### ERROR Statement

Purpose: To simulate the occurrence of an error, or to allow error codes to be defined by the user

Format: ERROR <n>

<n> is the error code to be simulated.

Remarks:

Error code numbers 1 to 255 are predefined and reserved by BASIC. Higher numbers can be used for user-defined error code messages. User-defined error codes can be used together with the ON ERROR GOTO statement to branch the program to an error handling routine.

When the ERROR statement is executed without an accompanying ON ERROR GOTO statement, the error message corresponding to the specified error number is output and program execution is stopped. The message UNDEFINED ERROR is displayed if an undefined error occurs.

The error number is assigned to the variable ERR and the line number where the error occurred is assigned to the variable ERL.

### FOR and NEXT Statements

Purpose: To allow a series of instructions to be performed in a loop a given number of times

Format: For <var>=<x> TO <y> [STEP<z>]

<x>, <y>, and <z> are numeric expressions.

Example: 100 FOR Y = base TO 10 STEP 2

110 NEXT Y

Remarks:

<var> is used as a counter. The first numeric expression (<x>) is the initial value of the counter. The second numeric expression (<y>) is the final value of the counter.

The program lines following the FOR statement are executed until the NEXT statement is encountered. Then the counter is incremented by the amount specified by STEP.

A check is performed to see if the value of the counter is now greater than the final value (<y>). If it is not greater, execution branches back to the first statement after the FOR statement and the process is repeated. If it is greater, execution continues with the statement following the NEXT statement. This is a FOR...NEXT loop.

If STEP is not specified, the increment is assumed to be one. If STEP is negative, the counter will count down instead of up. In this case, the loop will be executed until the counter is less than the final value.

The body of the loop will never be executed if the initial value of the loop is greater than the final value.

#### NESTED LOOPS

FOR...NEXT loops may be nested, that is, a loop can be placed inside of another loop. When loops are nested, each loop must have a unique variable name for its counter. The NEXT statement for the inside loop must come before the NEXT statement for the outer loop.

If nested loops have the same endpoint, the same NEXT statement can be used for both of them.

If a NEXT statement is encountered before its corresponding FOR statement, an error message is issued and execution is terminated.

### **GOSUB and RETURN Statements**

Purpose: To branch to and return from a subroutine

Format: GOSUB <line>

<line> is the first line number of the subroutine.

#### Remarks:

A subroutine may be called any number of times in a program, and a subroutine may be called from within another subroutine.

The RETURN statement(s) in a subroutine causes execution to branch back to the statement following the most recent GOSUB statement.

A subroutine may contain more than one RETURN statement should logic dictate a return at different points in the subroutine.

Subroutines can appear anywhere in the program, but it is recommended that subroutines be readily distinguishable from the main program.

To prevent inadvertent entry into a subroutine, the subroutine may be preceded by a STOP, END, or GOTO statement to direct program execution around the subroutine.

#### Program Example:

```

10   T = Time
20   GOSUB 100
30   {stuff}
40   .
50   .
60   .

```

```

90   GOTO 150
100
110  T = T + TIME
120  RETURN
130  {stuff}

```

**GOTO Statement**

Purpose: To unconditionally branch program execution to the specified line number

Format: GOTO <line>  
<line> is a valid line number.

Remarks:

If <line> is a non-executable statement, execution will proceed at the first executable statement encountered after <line>.

**IF...THEN Statement**

Purpose: To control program flow based on the results returned by an arithmetic or logical expression

Format: IF <expression> [ , ] THEN <statement(s)> or <line>  
[ELSE <statement(s)> or <line>]  
IF <expression> [ , ] GOTO <line>  
[[ , ] ELSE <statement(s)> or <line>]

Example: IF B=10 THEN PRINT "hello" ELSE 500

Remarks:

If the result of <expression> is not zero, the THEN or GOTO clause will be executed (GOTO is always followed by a line number). THEN may be followed by either a line number for branching or one or more statements to be executed.

If the result of <expression> is zero, the THEN or GOTO clause will be ignored and the ELSE clause, if present, will be executed. IF there is no ELSE clause, execution will continue with the next executable statement.

**INPUT Statement**

Purpose: To allow input from the keyboard during program execution

Format: INPUT [;] [#<port>][<"prompt">;]<variable>  
[,<variable>]...

#<port> is the port number (1 or 2).

<"prompt"> is a message that will be displayed when the INPUT statement is executed.

Examples: INPUT "DATA" : A\$  
INPUT #2, "DATA" , A\$, B\$

Remarks:

When an INPUT statement is executed, program execution pauses and a question mark is displayed to indicate the program is waiting for data. If <"prompt"> is included, the string is displayed before the question mark. The program will not continue execution until the user has entered the required data.

A comma may be used instead of a semicolon after the prompt string to suppress the question mark.

Data is not accepted by the INPUT statement until a carriage return is entered. Therefore input can be edited with the backspace and delete keys.

When more than two variables are input, they must be delimited by commas or colons.

The data entered is assigned to the variables specified by the INPUT statement. The number of values entered must be the same as the number of variables in the INPUT statement.

The variable names in the list may be numeric or string variable types as well as subscripted variables (array variable). The type of each entered data item must agree with the type specified by the variable name.

Strings input to an INPUT statement need not be surrounded by quotation marks.

Responding to INPUT with too many or too few items will cause an error message to be displayed prompting the user to re-enter the data.

If a peripheral device other than TERM or COMU is selected by the OPEN statement, neither the prompt statement nor “?” is displayed.

To eliminate “?” when COMU, etc., is selected by the OPEN statement, use the LINE INPUT command.

The INPUT statement cannot be executed in direct mode. If the port number is omitted, port 1 is assumed as the default port.

## KEY(n) Statement

Purpose: To enable, disable, or stop an interrupt invoked by key input and defined by the ON KEY GOTO or ON KEY GOSUB statements

Format: KEY(<n>) ON/OFF/STOP  
<n> is the key number (1-8).

Example: KEY(4) ON

Remarks:

The KEY ON statement enables an interrupt invoked by keyboard input. After this statement has been executed, an interrupt will be triggered each time the specified key is input. Program execution then branches to an interrupt service routine defined with the ON KEY GOTO or ON KEY GOSUB statements.

The KEY OFF statement disables the interrupt; key input will no longer trigger an interrupt.

The KEY STOP statement also disables the interrupt. However, if the interrupt is subsequently enabled with the KEY ON statement, execution will then branch to the interrupt service routine defined by the ON KEY GOTO or ON KEY GOSUB statements.

Execute the KEY OFF statement at the end of the program.

Program Example:

```

10 OPEN #1, "TERM:(42)"
20 ON KEY 1 GOSUB 100
30 On KEY 2 GOSUB 200
40 A=0
50 KEY ON
60 GOTO 60

```

```

100  PC READ "@D,0,1,14";A
110  RETURN
200  PC WRITE "@D,0,1,14";A
210  RETURN

```

**LET Statement**

Purpose: To assign the value of an expression on the right side of an equal sign to the variable on the left side

Format: [LET] <variable>=<expression>

Example: LET A = 1.2

Remarks:

Notice the word LET is optional, i.e., the equal sign is sufficient when assigning an expression to a variable name.

Assignment of a character variable to a numeric variable, and the reverse, are not permitted.

When assigning unmatched types of numeric variables, the variable type on the right side of the equal sign is converted into the type on the left before the assignment is performed.

String assignments should be enclosed in double quotation marks.

**LINE INPUT Statement**

Purpose: To input an entire line of characters (up to 255) from the keyboard or other input device without the use of delimiters

Format: LINE INPUT [#<port>,) ["<prompt>";]<string>

<port> is the port number (1 or 2).

"<prompt>" is a message displayed on the screen prompting the user for input.

<string> is a string variable that is assigned to the input character string.

Example: LINE INPUT #2,"DATE";A\$

Remarks:

All of the characters input from the end of the prompt to the carriage return are assigned to the character variable as a series of data. (Commas and colons are also treated as character data.)

A question mark is not displayed unless it is part of the prompt string.

The prompt statement is not displayed if a peripheral device other than TERM or COMU is selected with the OPEN statement.

The character string is not assigned to the variable until the carriage return key is pressed. Until then, the BASIC LED indicator on the ASCII Unit will blink indicating that the Unit is waiting for input of a carriage return.

If the port number is omitted, port 1 is assumed as the default port.

**MID\$ Statement**

Purpose: To replace a portion of one string with another string

Format: MID\$(<string 1>,<n>[,<m>]) = <string 2>

<string 1> is a string variable.

<n> is an integer expression from 1 to 255.

<m> is an integer expression from 0 to 255.

<string 2> is a string expression.

Example: MID\$(A\$,2,4) = "ABCDEFGH"

Remarks:

The characters in <string 1>, beginning at position <n> are replaced by the characters in <string 2>.

The optional <m> refers to the number of characters from <string 2> that will be used in the replacement. If <m> is omitted, all of <string 2> is used. However, regardless of whether <m> is included, the replacement of characters never goes beyond the original length of <string 1>.

Refer to the discussion of the MID\$ function

### ON COM GOSUB Statement

Purpose: Defines an interrupt service routine to handle data coming into a com port buffer

Format: ON COM(<n>) GOSUB <line>

<n> is the port number (1 or 2).

<line> is the line number of the first statement of the interrupt service routine.

Example: ON COM1 GOSUB 1000

Remarks:

This statement is not valid unless it is executed after the specified port has been opened.

An interrupt service routine cannot be interrupted by another interrupt. If a new interrupt occurs during processing of a previous interrupt, branching to handle the new interrupt will not take place until after the RETURN statement of the first interrupt service routine is executed. This means that, depending on the branch timing, nothing may be in the buffer when execution branches to the interrupt routine. It is therefore necessary to check whether data is in the buffer by executing the LOC or EOF Command at the beginning of the interrupt routine.

All subroutines must end with a RETURN statement.

If a statement specified by the branch line number is non-executable, execution will begin with the first executable statement following the branch line number.

If zero is specified as the branch line number, it is assumed that the COM OFF statement has been executed.

If the port number is omitted, port 1 is selected.

The ON COM GOTO statement is enabled with the COM ON statement and disabled with the COM OFF statement.

Program Example:

```

10 OPEN #1, "COMU:(40)"
20 ON COM GOSUB 100
30 COM ON
40 PC READ "@D,0,2,2I4";A,B
50 PRINT A, B
60 GOTO 30

```

```

100  IF LOC (1)=0 THEN 120
110  PRINT INPUT$ (LOC(1),#1)
120  RETURN

```

Program Remarks:

If an interrupt from port 1 is detected, the buffer contents are displayed.

- Note**
1. If an interrupt is received on a communications line during processing of an interrupt routine, a RETURN statement will be returned and a branch will be made again to the interrupt routine. When this happens, there may be nothing in the buffer depending on the timing of the interrupt. To handle this, always place LOC and EOF at the beginning of the interrupt routine to check if there is data in the buffer, as shown at line 100 in the application example given above.
  2. When determining the contents of processing for interrupt routines, study the relationship between the communications speed and processing speed so that the receive buffers do not overflow while processing the interrupt routine.

**ON ERROR Statement**

Purpose: To enable error processing and to specify the first line number of the error handling routine

Format: ON ERROR GOTO <line>  
<line> is any valid line number.

Remarks:

When an error occurs, this statement directs execution to the proper error handling routine. When an error is detected, the error number is assigned to the variable ERR and the line number where the error occurred is assigned to ERL.

To disable error processing, execute ON ERROR GOTO 0. Subsequent errors will cause an error message to be printed and execution to be halted.

If an error occurs during execution of an error handling subroutine, a BASIC error message will be printed and execution terminated.

Refer to the discussion of the RESUME Command, and the ERR and ERL functions.

**ON GOSUB and ON GOTO Statements**

Purpose: To branch to one of several specified line numbers, depending on the resultant evaluation of a numeric or logical expression

Format: ON <expression> GOTO <list>  
ON <expression> GOSUB <list>  
<expression> is any valid expression.  
<list> is a list of valid line numbers separated by comas.

Example: ON X-2 GOSUB 50,100,150

Remarks:

The value of <expression> determines which line number in the list will be used for branching. For example, if the result is 2, then the second line number in the list will be chosen for branching. If the resultant value is not an integer, the fractional part is rounded off.

In the ON...GOSUB statement, each line number in the list must be the first line number of a subroutine.

If the value of <expression> is zero or greater than the number of items in the list, execution continues with the next executable statement. If the value of <expression> is negative or greater than 255, an error message will be displayed.

### ON KEY GOSUB Statement

Purpose: Defines an interrupt service subroutine to handle specific keyboard input

Format: ON KEY(<n>) GOSUB <line>

<n> is a numeric expression from one to eight indicating a specific key.

Example: ON KEY 1 GOSUB 1000

Remarks:

An interrupt service routine cannot be interrupted by another interrupt. If a new interrupt occurs during processing of a previous interrupt, branching to handle the new interrupt will not take place until after the RETURN statement of the first interrupt service routine is executed.

If a statement specified by the branch line number is non-executable, execution will begin with the first executable statement following the branch line number.

If zero is specified as the branch line number, it is assumed that the KEY OFF statement has been executed.

If the port number is omitted, port 1 is selected.

There should be only one ON KEY GOTO statement for each key number.

Key input will not be processed during execution of an assembly language program.

The ON KEY GOSUB statement is enabled with the KEY ON statement and disabled with the KEY OFF statement.

Program Example:

```

10 OPEN #1,"TERM:(42)"
20 ON KEY 1 GOSUB 100
30 ON KEY 2 GOSUB 200
40 ON KEY 3 GOSUB 300
50 KEY ON
100 PRINT A
110 RETURN
200 PRINT B
210 RETURN
300 PRINT C
310 RETURN

```

Program Remarks:

"A", "B", and "C" are displayed by pressing keys 1, 2, and 3, respectively. To cancel the specification, write 0 as the branch destination.

### ON KEY GOTO Statement

Purpose: To branch program execution to a specified line number in response to a specific key input

Format: ON KEY<n> GOTO <line>

<n> is an integer in the range of 1 to 8.



<line> is any valid line number.

Example: ON KEY 1 GOTO 1000

Remarks:

If a statement specified by the branch line number is non-executable, execution will begin with the first executable statement following the branch line number.

If zero is specified as the branch line number, it is assumed that the KEY OFF statement has been executed.

If the port number is omitted, port 1 is selected.

There should be only one ON KEY GOTO statement for each key number.

Key input will not be processed during execution of an assembly language program.

The ON KEY GOTO statement is enabled with the KEY ON statement and disabled with the KEY OFF statement.

Program Example:

```

10 OPEN #1,"TERM:(42)"
20 ON KEY 1 GOTO 100
30 ON KEY 2 GOTO 200
40 ON KEY 3 GOTO 300
50 KEY ON
100 PRINT "A"
110 GOTO 500
200 PRINT "B"
210 GOTO 5000
300 PRINT "C"
500 {cont. processing}

```

Program Remarks:

"A", "B", and "C" are displayed by pressing keys 1, 2, and 3, respectively. To cancel the specification, write 0 as the branch destination.

### ON PC ... GOSUB Statement

Purpose: Defines an interrupt service routine invoked by the PC

Format: ON PC [<int num>] GOSUB <line>

<int num> is an integer from 1 to 15.

<line> is a valid line number.

Example: ON PC 3 GOSUB 1000

Remarks:

The interrupt number is indicated with bits 04 to 07 (1 to F in hexadecimal) of the first of the four memory words assigned to each ASCII Unit in the PC's data memory area.

An interrupt routine invoked by the ON PC statement cannot be interrupted by another interrupt. If a new interrupt occurs during processing of a previous interrupt, branching to handle the new interrupt will not take place until after the RETURN statement of the first interrupt service routine is executed.

If the statement specified by the branch line number is non-executable, execution will begin with the first executable statement following the branch line number.

If zero is specified as the branch line number, it is assumed that the KEY OFF statement has been executed.

If the interrupt number is omitted, the same branch destination is assumed for all interrupt numbers, 1 through 15.

The ON PC GOSUB statement is enabled with the PC ON statement and disabled with the PC OFF statement.

Program Example:

```

10  ON PC 1 GOSUB 100
20  ON PC 2 GOSUB 200
30  PC ON
100 PC READ "H4,I2";I, J
110 PRINT I, J
120 RETURN
200 INPUT A
220 PC WRITE "14"; A
230 RETURN
    
```

Program Remarks:

When interrupt 1 is invoked, program execution branches to statement 100, reads two words of data from the PC, and displays them on the CRT.

When interrupt 2 is invoked, program execution branches to statement 200 and writes data entered through the keyboard to the PC.

Programming Interrupts:

Interrupting from the PC is prohibited while the ASCII busy flag is ON, and so in this case the ON PC GOSUB statement will not be executed. For this reason, interrupting will not be possible during the execution of PC READ and other statements that turn ON the ASCII busy flag. When programming using statements for which the ASCII busy flag turns ON during execution (e.g., PC READ) and the ON PC GOSUB statement, design the program so that no interrupts are invoked while the ASCII busy flag is ON. It is also recommended that for programs where interrupts are activated by turning ON the WRITE flag, correct operation is confirmed before actual use.

Ladder Program at the PC (Unit Number = #0)

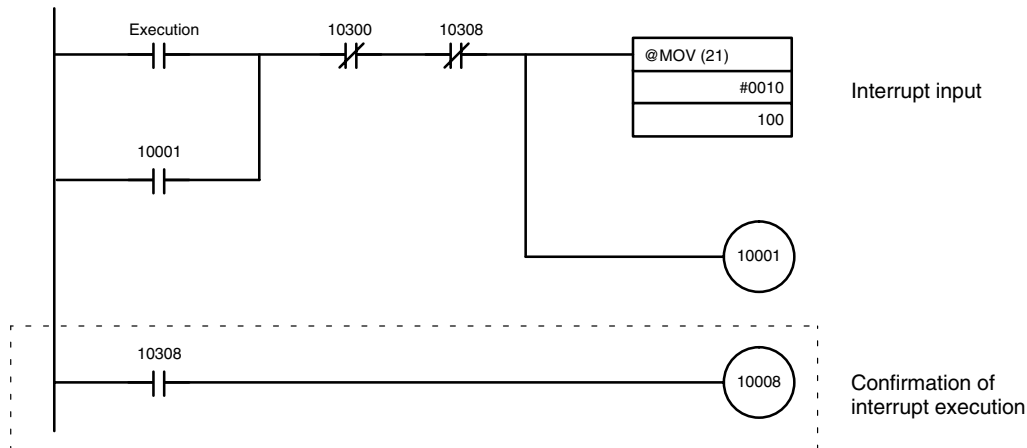

BASIC Program (at the ASCII Unit)

```

10      ON PC 1 GOSUB 100
20      PC ON

30      PC GET A, B
40      IF B=1 THEN PC PUT 0

50      GO TO 30
60      END

100     PC PUT 1

110     Interrupt processing
120     RETURN

```

B = Bit 10008.  
If B = 1 then 10308 is turned OFF.

10308 is turned ON.

**Remarks:**

An interrupt is invoked at the ASCII Unit from the PC program, avoiding the time at which the ASCII busy flag is ON. When the WRITE flag turns ON, the ON PC GOSUB statement is executed by the ASCII Unit. The ASCII Unit notifies the PC that interrupt processing has been executed by turning ON bit 10308. The PC acknowledges this notification by turning ON 10008. When 10008 is turned ON, the ASCII Unit turns OFF bit 10308.

**PC GET Statement**

**Purpose:** To read output data from the PC

**Format:** PC GET <var 1>[,<var 2>]

**Example:** PC GET I,J

**Remarks:**

Bits 0 through 7 of Data Section word (n) are read and assigned to <var 1>. Bits 8 through 15 of Data Section word (n) are read and assigned to <var 2>.

The ASCII Unit converts the hexadecimal data into decimal data (0 through 255) before assigning it to the specified variables.

**PC ... ON/OFF/STOP Statement**

**Purpose:** To enable, disable, or stop a PC interrupt defined with an ON PC GOSUB statement

**Format:** PC [<num>] ON/OFF/STOP

<num> is a specific interrupt number.

**Remarks:**

The PC ON statement enables an interrupt defined by the ON PC GOSUB statement.

After this statement has been executed, each PC interrupt will cause program execution to branch to a routine defined by the associated ON PC GOSUB statement.

The PC STOP statement disables PC interrupts from branching program execution. However, if the PC ON statement is subsequently executed, execution will branch to the specified interrupt service routine based on the "STOPPED" interrupt.

Execute the PC OFF statement at the end of the program.

The PC ON/OFF/STOP statement can be executed only after the ON PC GOSUB statement has been executed.

If there is more than one interrupt routine in the program the specific interrupt number should be specified. If there are two or more routines and the interrupt number is not specified, the routine closest to the end of the program or

at the highest line number will be executed regardless of which interrupt is invoked.

Program Example:

```

10  ON PC GOSUB 100
20  PC ON
30  GOTO 30
100 PC READ "3I2"; A, B, C
110 PRINT A, B, C
120 RETURN

```

### PC PUT Statement

Purpose: To write data to the PC's ASCII Unit Data Memory Area

Format: PC PUT <num exp>

<num exp> is a valid numeric expression between 0 and 255.

Examples: PC PUT I

PC PUT 123

Remarks:

Data is written to bits 8 through 15 of word n+3, where n is the first of the four PC Data Memory words assigned to each ASCII Unit.

If the value of the numeric expression is not an integer, the INT function is internally executed to round it off. If the value of the numeric expression is negative or greater than 255, zero is written to the PC.

### PC READ Statement

Purpose: To read data from the PC

Format: PC READ "<format>[,<format>,<format>, ...]";  
<var1>[,<var2>],...

<format> specifies how the data will be read. For specific format information, refer to *Appendix D Formatting and Data Conversion*.

Examples:

PC READ "2H1, A3, I4, O2"; X, Y, A\$, I, J

Remarks:

When the PC has written the data to the ASCII Unit, the PC READ statement is executed.

If the PC has not written the data to the ASCII Unit, the ASCII Unit will wait for the data, and the PC READ statement is not executed until the data comes.

If the number of data items output by the PC is greater than that specified by the format parameters, the excess part of the output data will be ignored.

The maximum number of data items that can be transferred with one READ statement specification is 255 in the S or A formats.

If an amount of memory greater than the actual memory area is specified by the READ statement, a FORMAT ERROR will occur.

The PC READ statement's formatting parameters can be assigned to a single character variable and that variable may then be used in the PC READ statement.

Refer to *Appendix D Formatting and Data Conversion* for details on READ and WRITE statement formatting.

Example:

A\$ = "2H1, A3, I4, O2"

PC READ A\$;X, Y, A\$, I, J

### PC WRITE Statement

Purpose: To write data to the PC

Format: PC WRITE "<format>[,<format> ...]";<exp1>  
[,<exp2>, ...]

**Note** For parameter definitions, refer to Appendix C.

Examples:

PC WRITE "H4, A2, I3, O4"; 1234, "AB", K, L

Remarks:

If the data of the previous PC WRITE statement has not been read by the PC, the next PC WRITE statement cannot be executed until the previous one is completed.

The maximum number of data items that can be transferred with one WRITE statement specification is 255 in the S or A formats.

If an amount of memory greater than the actual memory area is specified by the WRITE instruction, a FORMAT ERROR will occur.

If the value of <exp> is not an integer, the INT function is internally executed to round it off.

Single-precision and double-precision numeric expressions are internally converted into integer expressions.

The PC WRITE statement's formatting parameters can be assigned to a single character variable and that variable may then be used in the PC WRITE statement.

Example:

A\$="H4, A2, I3, O4"

PC WRITE A\$; 1234, "AB", K, L

### POKE Statement

Purpose: To write one byte to a specified memory address

Format: POKE <address>,<data>

<address> is the memory location where data will be POKEd.

<data> is an integer from 0 to 255.

Example: POKE &H2000,&H39

Remarks:

The address must be a 2-byte integer ranging from 0 to 65535 (&HFFFF). Do not write data to addresses &H0000 to &H2000, and &H8000 to &HFFFF; they are reserved for system use.

### PRINT/LPRINT Statement

Purpose: To output data and text to the screen or printer

Format: PRINT [#<port>,<list of exp>][:;]

## LPRINT

<port> is an integer (1 or 2).

<list of exp> can be numeric or character expressions. Character expressions should be enclosed in double quotation marks.

Example: PRINT #1,A,B\$;"BASIC"

Remarks:

The list of expressions must be separated by commas, semicolons, or blanks. When the expressions are separated with blanks or semicolons, the next value is output immediately after the preceding value. When the expressions are separated with commas, the values are output at intervals of nine characters.

If the list of expressions is not terminated with a semicolon, a carriage return is appended after the last expression.

If numeric expressions are used, a blank is output before and after the resultant value. The blank before the value is used for a minus sign, if one is required.

If <list of exp> is omitted, execution of this statement causes a carriage return to be output.

If the port specification is omitted, port 1 is assumed for the PRINT statement, and port 2 for the LPRINT statement.

The LPRINT statement outputs data under control of the device connected to port 2, irrespective of the OPEN statement directives.

**PRINT/ LPRINT USING Statement**

Purpose: To output strings or numbers according to a specified format

Format: PRINT [#<port>,) USING "<format>"; <list of exp>

Example: PRINT #1, USING "####,# \###";A;B

Remarks:

The following characters control the format of the output:

- ! Outputs the first character only.
  - & & Outputs the characters enclosed by &.
  - @ Outputs the corresponding character string.
  - # Outputs the corresponding character string.
  - . Inserts a decimal point at any desired place.
  - + Places a plus sign before and after a numeric value.
  - Places a minus sign before and after a numeric value. (Write this character at the end of the format character string.)
  - \*\* Places two asterisks in the blank, upper digit positions of a numeric value.
  - \\ Places one \ in the blank digit position immediately before a numeric value.
  - \*\*\ Combines the functions of \*\* and \\.
  - ,
- Delimits an integer at every third digit position from the right.

- ^^^ Indicates the output in exponential format (E+nn). Add this character after #.
- "" is output before the numeric value if the specified number of digits is too great.

If the port number is omitted, port 1 is assumed for the PRINT USING statement and port 2 for the LPRINT USING statement.

The LPRINT statement outputs data under control of the peripheral device connected to port 2 irrespective of the OPEN statement directives.

### RANDOM Statement

Purpose: To reseed the random number generator

Format: RANDOM [<exp>]

<exp> is a single or double-precision integer that is used as the random number seed.

Example: RANDOM 5649

Remarks:

The value of <exp> should be from -32768 to 32767. If the expression is omitted, a message requesting the random number seed will be displayed.

If the random number generator is not reseeded, the RND function returns the same sequence of random numbers each time the program is run. To change the sequence of random numbers each time the program is RUN, place a RANDOM statement at the beginning of the program and change the seed with each RUN.

For more information, refer to the explanation of RND.

### READ Statement

Purpose: To read values from a DATA statement and assign them to the specified variables

Format: READ <list of var>

Example: READ A,B\$

Remarks:

A read statement must always be used in conjunction with a DATA statement. READ statements assign variables to DATA statement values on a one-to-one basis. READ statement variables may be numeric or string, and the values read must be the same type as the corresponding variable. If they do not agree, a syntax error will occur.

A single READ statement may access one or more DATA statements (they will be accessed in order), or several READ statements may access the same DATA statement.

If the number of variables in <list of var> exceeds the number of elements in the DATA statement(s), an error message will be displayed. If the number of variables specified is fewer than the number of elements in the DATA statement(s), subsequent READ statements will begin reading data at the first unread element. If there are no subsequent READ statements, the extra data is ignored.

To reread DATA statements from the beginning, use the RESTORE statement.

### REM Statement

Purpose: To insert non-executable comments in a program

Format: REM <remark>

<remark> text does not need to be enclosed in quotes.

Example: REM SAMPLE PROGRAM

Remarks:

The REM statement is used to provide titles to programs and to insert helpful comments to be used during program debugging or modification.

Remarks may be added to the end of a line by preceding the remark with a single quotation mark instead of: REM.

Do not use a REM statement in a DATA statement as it will be taken as legal data.

### RESTORE Statement

Purpose: To allow DATA statements to be reread from a specified line

Format: RESTORE [<line>]

<line> should be the line number of a valid DATA statement.

Example: RESTORE 1000

Remarks:

This statement causes the next READ statement to read the first element in the first DATA statement that exists in the program. If <line> is specified, the next READ statement accesses the first item in the specified DATA statement.

### RESUME Statement

Purpose: To resume program execution after an error handling procedure has been performed

Formats: RESUME [0]: execution resumes at the statement which caused the error.

RESUME NEXT: execution resumes at the statement immediately following the one which caused the error.

RESUME <line>: execution resumes at <line>.

Example: RESUME 100

Remarks: Any one of the above formats may be used.

### STOP Statement

Purpose: To terminate program execution and return to the BASIC command level

Format: STOP

Remarks:

Execution of this statement causes the message "BREAK IN xxxx" to be displayed and the ASCII Unit to return to the command level.

The ports will not be closed.

Program execution can be resumed with the CONT command.

### WAIT Statement

Purpose: Sets a time limit for the execution of a specific statement

Format: WAIT "<wait time>"[,<line number>]



<wait time> is the allowable time for the monitored statement to be executed.

<line number> is any valid line number.

Example: WAIT "10:30.5",100

Remarks:

The delay time is set in the form MM.SS.F, where:

MM is the number of minutes up to 59

SS is the number of seconds

F is tenths of seconds.

The statement immediately following the WAIT statement is the monitored statement. If execution of this statement is not completed within the set wait time, program execution will branch to <line number>.

Interrupts invoked by the ON COM, ON KEY, ON PC, or ON ERROR statements will not be recognized until after the WAIT statement or the monitored statement has been processed.

The WAIT statement can monitor the following statements:

INPUT, INPUT\$, LINE INPUT, PC READ, PC WRITE, PRINT, LPRINT, PRINT USING, LPRINT USING

If a statement other than one of those listed above is specified to be monitored by a WAIT statement, and if execution of that statement is not completed within the set time of the WAIT statement, an error will occur.

Program Example:

```

10  WAIT "10.0", 100
20  PC READ "314"; A, B, C,
30  PRINT A, B, C
40  END
100 PRINT "PC ERR"
110 GOTO 40

```

Program Remarks:

This example will display the message "PC ERR" if the PC READ statement is not executed within 10 seconds.

## 4-2-4 Device Control Statements

This section describes statements that control hardware and communications.

### CLOSE Statement

Purpose: To close a port

Format: CLOSE [#<port>]

<port> is an integer (1 or 2).

Remarks:

If the port number is omitted, both ports will be closed.

Once the port has been closed, it cannot be used for data transfer until it is opened again.

Be sure to execute the CLOSE statement to correctly end the output process. CLOSE dumps any data remaining in the buffer from output operations. It does not dump data from input operations.

The END statement and the NEW command automatically close the ports, but the STOP statement does not.

**CLS Statement**

Purpose: To clear the screen

Format: CLS [#<port>]

<port> is an integer (1 or 2).

Remarks:

This statement clears the screen and moves the cursor to the home position. If the port number is omitted, port 1 is assumed.

**OPEN Statement**

Purpose: To allow input/output operations to take place through the specified port

Format: OPEN #<port>, "<device name>:[(<com spec. or vsl>)]"

<port> is an integer (1 or 2).

<device name> identifies the device.

<com spec> stands for the communication specifications.

<vsl> stands for valid signal line.

Examples: OPEN #1,"KYBD:"

OPEN #2,"COMU:(14)"

The following three tables define the communication parameters for the OPEN Statement.

Peripheral Device	Name	Output from ASCII Unit	Input to ASCII Unit
Terminal	TERM:	YES	YES
Keyboard	KYBD:	NO	YES
Display	SCRN:	YES	NO
Printer	LPRT:	YES	NO
RS-232C device	COMU:	YES	YES

Communication Specifications	Character Length	Parity	Stop Bit
0	7 bits	Even	2 bits
1	7 bits	Odd	2 bits
2	7 bits	Even	1 bit
3	7 bits	Odd	1 bit
4	8 bits	None	2 bits
5	8 bits	None	1 bit
6	8 bits	Even	1 bit
7	8 bits	Odd	1 bit

Signal Line	CTS	DSR	RTS	XON/XOFF
0	Valid	Valid	Valid	Invalid
1	Valid	Valid	Invalid	
2	Valid	Invalid	Valid	
3	Valid	Invalid	Invalid	
4	Invalid	Valid	Valid	
5	Invalid	Valid	Invalid	
6	Invalid	Invalid	Valid	
7	Invalid	Invalid	Invalid	
8	Valid	Valid	Valid	Valid
9	Valid	Valid	Invalid	
A	Valid	Invalid	Valid	
B	Valid	Invalid	Invalid	
C	Invalid	Valid	Valid	
D	Invalid	Valid	Invalid	
E	Invalid	Invalid	Valid	
F	Invalid	Invalid	Invalid	

Remarks:

To make the CTS signal invalid at port 2, pull the CTS line high or connect it to the RTS line.

When the RTS is specified to be ON (valid), the RTS signal goes high when the port is opened and remains high until the port is closed. When the RTS signal is specified to be OFF (invalid), the RTS signal remains low unless an I/O statement such as PRINT or INPUT is executed.

When continuously receiving data from a peripheral device, specify RTS ON. When implementing the interrupt function with ON COM, specify RTS ON. If RTS OFF is specified, interrupts will not be received.

When data is received with the XON code specified to be valid, and the data buffer is filled to 3/4 of its capacity, the XOFF code is sent, requesting a pause of transfer. If the contents of the receive buffer decrease to 1/4 of the buffer capacity, the XON code is sent, requesting resumption of transfer.

When the XOFF code is received during data transfer, transfer is paused. When the XON code is received, transfer is resumed.

If the communication specification and the valid signal line are omitted, their defaults are:

Peripheral Device	Communication Conditions	Valid Signal Line
Terminal	4	3
Keyboard	4	3
Display	4	3
RS-232C device	4	3
Printer	4	5

Ports already open cannot be opened again. When the OPEN and CLOSE statements are used, port 1 is assumed to be for a terminal and port 2 is assumed to be for a printer. Port 2 cannot be selected for a terminal.

I/O statements specifying #<port> cannot be used to transfer data through a port that has not been opened with the OPEN statement. To input/output data in the case where the OPEN statement has not been executed, use the I/O statements without the #<port> specification.

The following two tables illustrate peripheral device output levels during execution of the OPEN statement.

Device	When Opened		During Operation	
	RTS	DTR	RTS	DTR
TERM	LOW	HIGH	HIGH	No Change
SCRN	LOW	LOW	HIGH	No Change
KEYB	LOW	HIGH	HIGH	No Change
COMU	LOW	HIGH	HIGH	No Change
LPRT	LOW	LOW	HIGH	No Change

Port	When Closed	
	RTS	DTR
1	LOW	HIGH
2	LOW	LOW

Remarks:

The default selection for the ports is as follows:

port 1: Terminal device

port 2: Printer

The following table presents the output control codes for the terminal, printer, and COMU device.

SCRN TERM	Open	Clears the screen buffer when code &H0C (CLR) is output..The column position is set to 0 (i.e., the leftmost position) when code &H0A (LF), &H0D (CR), &H0B (HOME), or &H08 (BS) is output. The cursor is moved as specified on the screen when code &H08 (BS), &H1C (->), or &H1D (<-) is output. Codes &H00 to &H09 and &H0E to &H1B are ignored (not output).
	Closed	Nothing is executed.
LPRT	Open	Sets the column position to 0 (i.e., the leftmost position) when code &H0A, &H0D, &H0B, or &H0C is output. Characters exceeding 80th character are output with code &H0A (LF) appended.
	Closed	If characters (80 characters or less) remain in the buffer, they are output along with &H0A (LF).
COMU	Open	If characters are input to the buffer, they are output.
	Closed	If characters remain in the buffer, they are output.

### 4-2-5 Arithmetic Operation Functions

#### ABS Function

Purpose: To return the absolute value of the numeric expression specified by the argument

Format: ABS(<x>)

Example: A = ABS (-1.5)

#### ACOS Function

Purpose: To return the arc cosine of the numeric expression given by the argument

Format: ACOS(<x>)

<x> is a number in the range of -1 to 1.

Example: A = ACOS (1)

Remarks: The arc cosine is given in radian units in the range of 0 to pi.

### ASIN Function

Purpose: To return the arc sine of the value given by the argument

Format: ASIN(<x>)

<x> is a number in the range of -1 to 1.

Example: A = ASIN (1)

Remarks: The arc sine is given in radian units in the range of -pi/2 to pi/2.

### ATN Function

Purpose: To return the arc tangent of the value given by the argument

Format: ATN(<x>)

<x> is a number in the range of -1 to 1.

Example: A = ATN (1)

Remarks: The arc tangent is given in radian units in the range of -pi/2 to pi/2.

### CDBL Function

Purpose: To convert a single-precision numeric value into double-precision

Format: CDBL(<x>)

Example: CDBL (2/3)

### CINT Function

Purpose: To round off a numeric value at the decimal point and convert it into an integer

Format: CINT(<x>)

Example: A = CINT(B#)

### COS Function

Purpose: To return the cosine of the numeric value given by the argument

Format: COS(<x>)

<x> is an expression in radian units.

Example: A = COS(pi/2)

### CSNG Function

Purpose: To convert a numeric value into a single-precision real number

Format: CSNG(<x>)

Example: B = CSNG(C#)

### FIX Function

Purpose: To return the integer part of the expression specified by the argument

Format: FIX(<x>)

Example: A = FIX(B/3)

Remarks: If the value of the argument is negative, this function returns a different value than the INT function returns.

**INT Function**

Purpose: To return the truncated integer of a numeric value

Format: INT(<x>)

Example: A = INT(B)

Remarks:

Returns the largest integer value less than or equal to the value specified by the argument.

If the value of the argument is negative, this function returns a different value than the FIX function returns.

**LOG Function**

Purpose: To return the natural logarithm of the argument

Format: LOG(<x>)

<x> must be greater than 0.

Example: A = LOG(5)

**RND Function**

Purpose: To return a random number between 0 and 1.

Format: RND [<x>]

Example: A = RND(1)

Remarks:

If <x> is negative, a new random number is generated.

If <x> is omitted, or if it is positive, the next random number of the sequence is generated.

If <x> is 0, the last generated random number is repeated.

The sequence can be changed by executing the RANDOM statement.

**SGN Function**

Purpose: To return the sign of an argument

Format: SIGN(<x>)

Example: B = SGN(A)

Remarks:

If the value of <x> is positive, SGN returns 1.

If the value of <x> is negative, SGN returns -1.

If the the value of <x> is 0, SGN returns 0.

**SIN Function**

Purpose: To return the sine of the numeric value given by the argument

Format: SIN(<x>)

<x> is an expression in radian units.

Example: A = SIN(pi)

**TAN Function**

Purpose: To return the tangent of the numeric value given by the argument

Format: TAN(<x>)

<x> is an expression in radian units.

Example: A = TAN(3.141592/2)

## 4-2-6 Character String Functions

### ASC Function

Purpose: To return the ASCII character code of the first character of the given string

Format: ASC(<x\$>)

Example: A = ASC(A\$)

Remarks:

An empty string cannot be specified. The CHR\$ function performs the inverse operation.

### CHR\$ Function

Purpose: To return a character corresponding to the specified character code

Format: CHR\$(<i>)

Example: A\$ = CHR\$(&H41)

Remarks:

<i> must be from 0 to 255. If <i> is a real number, it will be rounded off and converted into an integer. The ASC function performs the inverse operation.

### HEX\$ Function

Purpose: To return a string which represents the hexadecimal value of the decimal argument

Format: HEX\$(<x>)

Example: A\$ = HEX\$(52)

Remarks:

If the value of the decimal number includes a decimal point, the INT function is internally executed to round it off to an integer.

### INSTR Function

Purpose: To return the position of the first occurrence of string <y\$> within string <x\$>

Format: INSTR([<i>,<x\$>,<y\$>)

<i> is the position from where the search starts. <i> must be between one and 255.

<x\$> is the string to be searched.

<y\$> is the desired string.

Example: A = INSTR(5,B\$,"BASIC")

Remarks:

If <i> is omitted, the search begins with the first character in <x\$>. If the data cannot be found, 0 is returned as the function value. If <y\$> is an empty string, INSTR returns <i> or 1.

### LEFT\$ Function

Purpose: To return the specified number of characters beginning from the leftmost character of the character string

**Format:** LEFT\$(<x\$>,<i>)  
 <x\$> is the string to be searched.  
 <i> is the number of characters to be returned.

**Example:** A\$ = LEFT\$(B\$,5)

**Remarks:**

<i> must be an integer from 0 to 255. If <i> is 0, an empty string is returned as the function value. If <i> is greater than the number of characters in <x\$>, the entire character string is returned.

### LEN Function

**Purpose:** To return the number of characters in a character string

**Format:** LEN(<x\$>)

**Example:** A = LEN(A\$)

**Remarks:** A value of 0 is returned if the "character expression" is an empty string.

### MID\$ Function

**Purpose:** To return the requested part of a given string

**Format:** MID\$(<x\$>,<i>[,<j>])

<x\$> is the given string.

<i> is the position of the first character to be returned.

<j> is the number of characters to be returned.

**Example:** B\$ = MID\$(A\$,2,5)

**Remarks:**

<i> must be from 1 to 255.

<j> must be from 0 to 255.

If <j> is 0, or if the value of the specified character position (<i>) is greater than the number of characters in the character expression (x\$), an empty string is returned.

If <j> is omitted, or if <j> exceeds the number of characters to the right of the specified position (<i>) in the character expression, all the characters to the right are returned.

### OCT\$ Function

**Purpose:** To convert the specified decimal number into an octal character string

**Format:** OCT\$(<x>)

<x> is a numeric expression in the range of -32768 to 32767.

**Example:** A\$ = OCT\$(B)

**Remarks:**

If the value of <x> includes a decimal point, the INT function is internally executed to round it off.

### RIGHT\$ Function

**Purpose:** To return the specified number of characters from the rightmost character of the character string



**Format:** RIGHT\$(<x\$>,<i>)  
 <x\$> is the string to be searched.  
 <i> is the number of characters to be returned.

**Example:** A\$ = RIGHT\$(B\$,5)

**Remarks:**

<i> must be an integer from 0 to 255. If <i> is 0, an empty string is returned as the function value. If <i> is greater than the number of characters in <x\$>, the entire character string is returned.

### SPACE\$ Function

**Purpose:** To return a string of spaces of the specified length

**Format:** SPACE\$(<x>)  
 <x> is the number of spaces.

**Example:** A\$ = "CF"+SPACE\$(5)+"BASIC"

**Remarks:**

<x> must be from 0 to 255. If <x> is not an integer, it will be rounded off. If 0 is specified, an empty character string is returned.

### STR\$ Function

**Purpose:** Converts the specified numeric value into a character string

**Format:** STR\$(<x>)

**Example:** B\$ = "A"+STR\$(123)

**Remarks:** The VAL function performs the inverse operation.

### STRING\$ Function

**Purpose:** To return a character string of the specified character and length

**Formats:** STRING\$(<i>,<j>)  
 STRING\$(<i>,<x\$>)  
 <i> is the number of characters to be returned.  
 <j> is the ASCII code of some character.  
 <x\$> is a given string.

**Example:** A\$ = STRING\$(10,"A")

**Remarks:**

<i> and <j> must be from 0 to 255.

An empty string is returned if the <i> is 0.

If the <x\$> is made up of two or more characters, only the first character is used.

### TAB Function

**Purpose:** To move the cursor to a specific position on the terminal display

**Format:** TAB(<i>)  
 <i> is the cursor position counting from the leftmost side of the display.

**Example:** PRINT "CF" TAB (10) "BASIC"

Remarks:

The “column position” must be from 1 to 255.

If the current print position is already beyond <i>, the cursor moves to the <i>th position on the next line. TAB is only valid for the PRINT and LPRINT statements.

**VAL Function**

Purpose: To convert a character string into a numeric value

Format: VAL(<x\$>)

Example: A = VAL(A\$)

Remarks:

The VAL function also strips leading blanks, tabs, and linefeeds from the argument string. If the first character of <x\$> is not numeric, zero is returned.

**4-2-7 Special Functions****DATE\$ Function**

Purpose: To set or display the current date

Format: As a statement: DATE\$ = <x\$>

As a variable: <y\$> = DATE\$

<x\$>: the date in one of the following formats:

mm-dd-yy

mm-dd-yyyy

mm/dd/yy

mm/dd/yyyy

<y\$>: A ten character string in mm-dd-yyyy format:

mm: two digit value for the month (01-12)

dd: two digit value for the day (01-31)

yy: two digit value for the year

yyyy: for digit value for the year

Example: DATE\$ = “89/05/23”

Remarks:

If DATE\$ is on the right side of the assignment statement or in a PRINT statement, the current date is assigned or printed, respectively. If DATE\$ is on the left side of the assignment, the right side of the assignment statement becomes the new current date. If any of the values are out of range or are missing, an error message will be displayed.

**DAY Function**

Purpose: To give or set the current day of the week

Format: DAY = <num>  
I = DAY

Remarks:

In the first format, DAY returns a number between 0 and 6, corresponding to Sunday through Saturday. In the second format, the day of the week is assigned to DAY.

**EOF Function**

Purpose: To check whether the specified port buffer is empty

Format: EOF (<port#>)

Example: IF EOF (2) THEN CLOSE#1 ELSE GOTO 100

Remarks:

This function returns true (-1) if the specified port is empty. If not, it returns false (0). Note that the port specified by <port#> must already be open and in the input mode.

**ERR and ERL Variables**

Purpose: To return the error code and the location (line number) of the error

Format: x = ERL

y = ERR

Remarks:

When an error occurs, the error code is assigned to the variable ERR and the statement number is assigned to ERL.

If the statement that caused the error was executed in direct mode, statement number 65535 is assigned to ERL.

ERL and ERR can be used in error handling routines to control the execution flow of the program.

**FRE Function**

Purpose: To return the amount of unused memory

Format: FRE(0)

FRE(<x\$>)

Example: PRINT FRE (0)

Remarks:

If the argument is numeric, the number of unused bytes in the program area is given.

If the argument is a character expression, the number of unused bytes in the character variable area is given.

**INKEY\$ Function**

Purpose: To return the character code of the key being pressed

Format: INKEY\$ [#<port>]

Example: A\$ = INKEY\$

Remarks:

A null string is returned if no key is being pressed. Any key input other than CTRL+X is valid. Port 1 is the default port.

**INPUT\$ Function**

Purpose: To Read a string of characters from the keyboard or from a peripheral device

Format: INPUT\$ (<num>[,#<port>])

<num> is the number of characters to be input. <num> must be from 1 to 255.

<port> is the port number (1 or 2).

Example: A\$ = INPUT\$(10,#1)

Remarks:

All characters except CTRL+X can be read, including CR and LF: CR and LF cannot be read with the LINE INPUT statement.

The BASIC LED indicator on the ASCII Unit will blink indicating that the Unit is waiting for input. It will continue blinking until the specified number of characters is entered.

Example Program:

```

10 CLS
20 A$ = INPUT$ (1)
30 A$ = HEX$ (ASC(A$))
40 PRINT A$
50 GOTO 20

```

Remarks:

Displays key character codes.

### LOC Function

Purpose: To return the number of data items in the specified port buffer.

Format: x = LOC(<port#>)

Example: A = LOC(2)

Remarks:

The port specified must already be open and in input mode. The number of data items in the buffer of the specified port is given in byte units.

### PEEK Function

Purpose: To read the contents of a specified memory address

Format: PEEK(<l>)

<l> is the memory location and must be in the range of 0 to 65535 (&HFFFF).

Example: A = PEEK(&H3000)

Remarks:

If the specified address is not an integer, it is converted into one.

Do not try to read reserved system addresses &H0000 through &H1FFF and &H8000 through HFFFF.

**Note** For details of memory structure, refer to *Appendix E ASCII Unit Memory Map*.

### TIME\$ Function

Purpose: Sets or gives the time

Format: TIME\$ = <x\$>

<y\$> = TIME\$

<x\$> is a string expression indicating the time to be set. The following formats may be used:

hh: sets the hour (minutes and seconds 00)

hh:mm: sets the hours and minutes (seconds 00)

hh:mm:ss: sets the hours, minutes, and seconds

<y\$> is a string variable to which the current value of the time is to be assigned.

Example: TIME\$ = "09:10:00"

PRINT TIME\$

Remarks:

In the form <y\$> = TIME\$, TIME\$ returns an eight character string in the form: hh:mm:ss. If <x\$> is not a valid string, an error message will be displayed.

**USR Function**

Purpose: To call a user-written assembly language program.

Format: USR [<number>](<argument>)[,W]

<number> is a digit from 1 to 9 that was previously assigned to the given assembly program with the DEF USR statement.

<x> is an argument used to pass data from the BASIC program to the assembly program.

Example: J = USR2(I),W

Remarks:

If <number> is omitted, the default value is zero.

If the W parameter in the USR statement is not specified, the watchdog timer refresh will be performed as usual. If the W parameter is specified, then the user must include a watchdog timer refresh routine in the assembly program.

The watchdog timer prevents the program from overrunning. When the set time has run out, the ASCII Unit is reset, and the message "I/O ERR" is displayed on the programming console of the PC.

By refreshing the watchdog timer before its set value is up, the program can be continuously executed.

To refresh the watchdog timer in the assembly program, execute the following two steps every 90 milliseconds:

AIM #DF,03

OIM #20,03

The following table lists the Argument type and its corresponding Accumulator code number.

Accumulator Value	Argument Type
2	Integer
3	Character
4	Single-precision, real number
8	Double-precision, real number

Index register X contains the memory address where the argument is stored. The address differs depending on the type of the argument as shown in the following diagram.

**Integer Type**

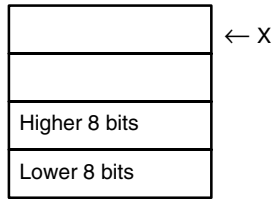

**Character Type**

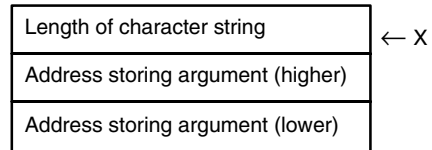

**Single-Precision, Real Number Type**

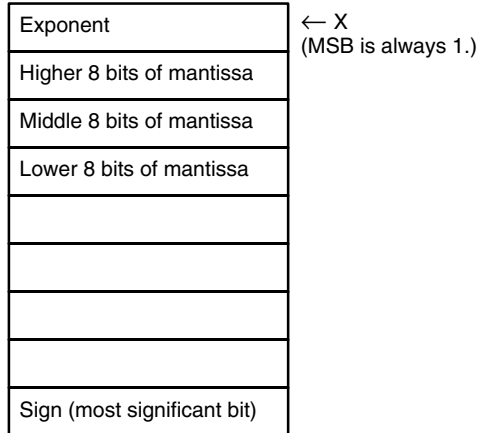

**Double-Precision, Real Number Type**

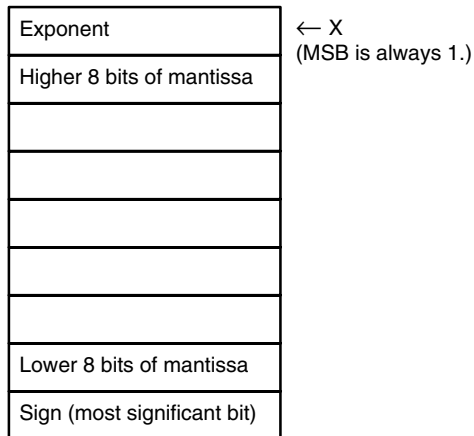

Program Example:

**BASIC Program:**

```

100  A$ = &H1234
110  DEF USR0 = &H2000
120  A = USER (A)
130  PRINT A
140  END
    
```

**Assembly language program:**

```

2000  PSHA
2001  PSHX
    
```

2002	LDD 2,X
2004	ADD #10
2007	STD 2,X
2009	PULX
2010	PULA
2011	RTS

Program Remarks:

When program execution branches to the assembly language routine, the TYPE of <argument> is stored in the accumulator A, and the memory address where the argument is stored is input to the index register X. The value of the argument is stored in the accumulator D, to whose contents &H10 will be added. The result of the addition is written to the address of <argument>.

## VARPTR Function

Purpose: Returns the memory address of the variable argument

Format: <x> = VARPTR(<variable>)

<variable> is a number, string, or array variable.

Example: B = VARPTR (A)

Remarks:

The VARPTR function returns the address of the first byte of data identified with the variable. A value must be assigned to the variable prior to the call to VARPTR or an error will result. Any type variable name may be used (numeric, string, array).

Note that all simple variables should be assigned before calling VARPTR for an array because addresses of arrays change whenever a new simple variable is assigned.

VARPTR is used to obtain the address of a variable or array so that it may be passed to an assembly language subroutine. A function call of the form VARPTR(A(0)) is specified when passing an array, so that the lowest addressed element of the array is returned.

The following figure illustrates the relationship between the variable type and the address indicated by VARPTR.

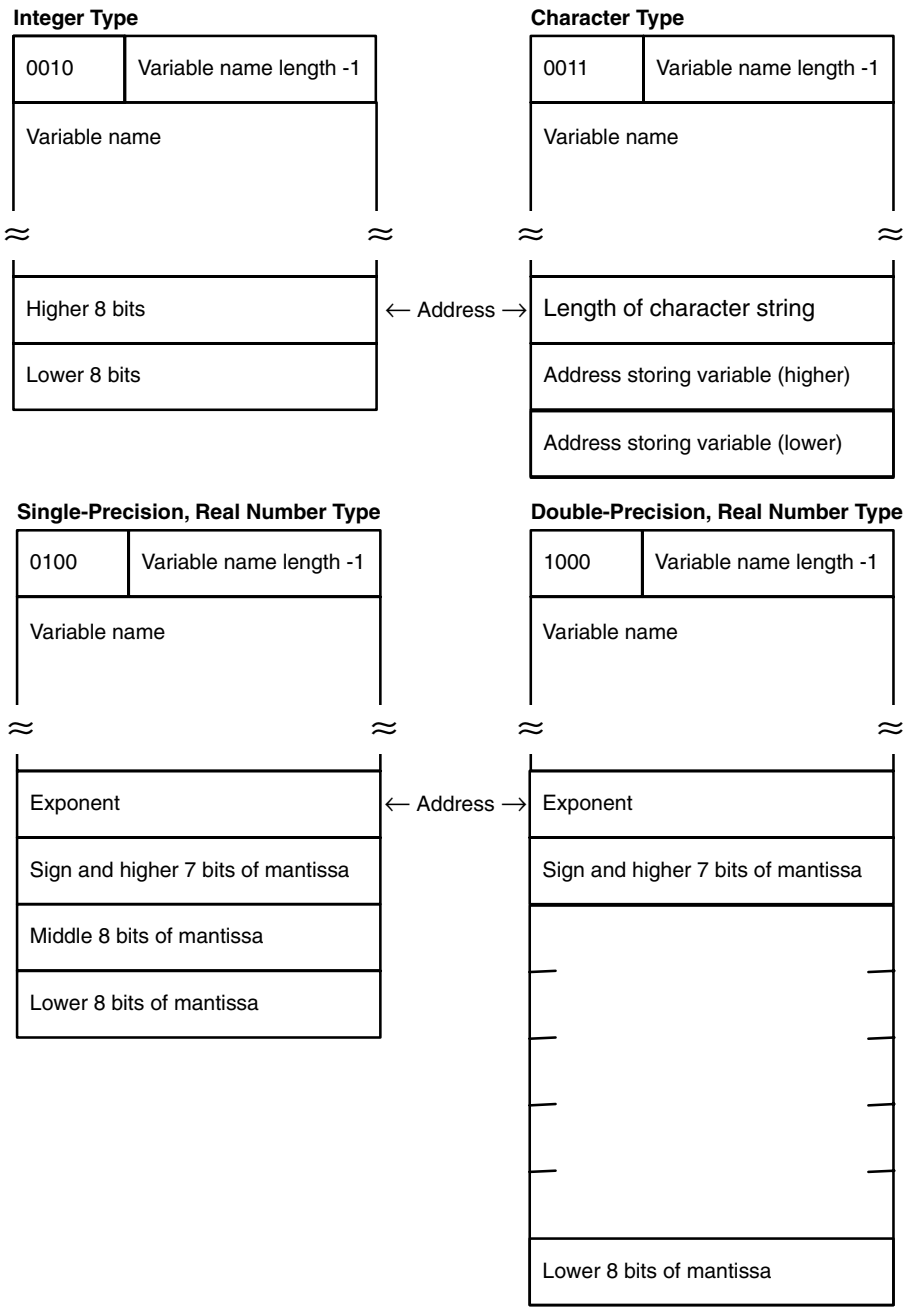



# SECTION 5

## Assembly Programming

This section explains how to create, edit, transfer, and use an assembly language program. Assembly programs are faster and use memory more efficiently than higher level programs such as BASIC. In certain situations it is advantageous to use assembly routines instead of BASIC to perform specialized functions. An assembly routine can be called from the BASIC program and used in much the same way as a BASIC subroutine.

Assembly programs are written, edited, and tested in what is called monitor mode. The monitor mode commands and examples of their use are presented in this section.

5-1	Assembly Language Programming .....	68
5-2	Terminology and Formatting .....	69
5-3	Monitor Mode Commands .....	69

## 5-1 Assembly Language Programming

### Memory Area

Special memory space for assembly language programs must be reserved with the MSET command. When programming in assembly language, you cannot use the BASIC program area to store the assembly program. The MSET command will move an existing BASIC program to another part of memory.

### Writing an Assembly Program

There are two ways to write an assembly language program:

- By using the monitor functions
- By directly writing the program to the memory using the POKE statement in BASIC.

In most cases the first method is quicker and easier; however, the second method can be used to create short programs consisting of only a few steps.

Assembly language programs can be written to and read from RAM using the S and L commands, respectively. They can also be written to or read from the EEPROM by using the SAVE and LOAD commands, respectively.

Addresses &H0000 to &H1FFF and &H8000 to &HFFFF are reserved for the ASCII Unit operating system and must not be altered by the user.

**Note** When it is necessary to load or save data using a peripheral device other than the input terminal connected to port 1, perform the peripheral data transfer procedure as follows:

- 1, 2, 3... 1. Enter the command and key-in a carriage return.
2. Disconnect the input terminal from port 1 and connect the peripheral device.
3. Press the START/STOP switch on the ASCII Unit to start data transfer.
4. Reconnect the input terminal and key-in ctrl+x.

### The Assembly Language Program

An assembly language program can be called from BASIC with the USR function:

```
USR [<number>][<argument>]
```

Before the USR function can be used, the DEF USR statement must be executed to reserve space for the assembly routine. When the USR function is executed, it calls the specified assembly routine and passes it an argument defined in the BASIC program. (Refer to *Section 4-2-7 Special Functions*.)

Variables other than the argument specified by the USR function can also be passed to the assembly language program by using the VARPTR function.

The following arguments are passed to the assembly program:

Accumulator A contents:    type of <argument>

Index register X contents:    address of <argument>

The RTS command should be the last command of the assembly routine; it returns execution back to the BASIC program.

The value of the stack pointer must not be altered by the assembly routine. Therefore, the data should be pushed on the stack at the beginning of the routine and then pulled off before the RTS command is executed.

The assembly routine must store any data needed by the BASIC program in the same address as that of the argument(s) passed by the USR or VARPTR functions. Any data passed back to the BASIC program must be of the same TYPE as the USR or VARPTR function argument(s).

Do not disable any interrupts in the assembly language program. It is recommended that the assembly language program be saved on an external storage device or in the EEPROM for safety.

### Monitor Mode

To enter monitor mode from BASIC mode, key-in “mon” followed by a carriage return when the message “READY” is displayed on the console:

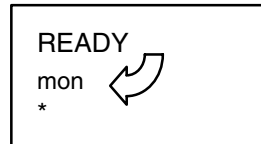

When in monitor mode “\*” is displayed on the leftside of the screen. Also, when in monitor mode, the BASIC LED on the ASCII Unit front panel is unlit. To return to BASIC mode, key-in CTRL+B.

## 5-2 Terminology and Formatting

### Terminology

**Start** address refers to the first memory address where a group of values stored in consecutive memory locations is stored: e.g., an array or a block of data.

For some monitor mode commands, indicating a start address is optional. For these commands, the address immediately following the highest or largest address used by the previous monitor command is taken to be the start address for the current monitor command. To simplify following explanations, this address will be called the **base** address.

An assembly language program can be edited, traced, and debugged in **monitor mode**.

Note that the address held in the **program counter** is the base address used for displaying and writing data when using the monitor commands.

### Format

The left and right arrow brackets “<” and “>” that have been previously used to denote “user supplied text” in BASIC programming format statements are used as actual operators in monitor mode. Therefore, whenever you see an arrow bracket character in a monitor mode command, it **must be entered as such**. The arrow character is used to delineate address ranges.

For monitor format statements only, left and right parentheses “( )” will be used to denote user-supplied text.

Brackets “[ ]” still indicate optional entry. Pay close attention to periods “.”; **they must be entered as such** whenever indicated.

The carriage return key is indicated with ↵. Whenever this appears in a command, a carriage return must be entered by the user.

**Do not insert spaces within a monitor command unless explicitly indicated.**

In the following examples, and also on the actual terminal, the “\*” character indicates that the user must enter a command. Lines of text that do not start with “\*” are generated by the computer in response to a user command.

## 5-3 Monitor Mode Commands

The following table lists the monitor mode commands with a short description of each command’s function as well as the page number on which its detailed explanation can be found.

Page	Command	Purpose
66	address	Displays/changes memory contents at the specified address.
68	M	Transfers memory contents.
69	C	Compares memory contents.
69	R	Displays/changes register contents.
70	BP	Sets/displays breakpoints.
70	N	Clears breakpoints.
71	I	Disassembler
71	S	Outputs data to a port.
72	L	Loads data from a port.
72	V	Verifies data.
73	G	Executes a program.
73	T	Single-step program execution
74	Mini-Assembler	Single-line assembly
74	Arithmetic	Addition/subtraction of hexadecimal numbers.

## DUMP Command

**Purpose:** To display the contents of memory in hexadecimal

**Format:** [(display start address)].[(display end address)]

### Remarks:

If the carriage return ↵ is input by itself, eight bytes of data starting from the base address will be displayed. (refer to example 2)

If an address is entered preceded by a period, e.g., “.3000”, data stored in all the addresses from the base address to the entered address will be displayed (refer to examples 3 and 4).

New data can be stored in memory as well; this data will overwrite existing data. Input data must be in hexadecimal. Upper case characters must be used for the alphanumeric values of A through F (hex). When the leftmost digit is a “0”, it can be omitted.

There are two ways to poke data (directly store data to a specific address).

- 1, 2, 3... 1. Specify the first address followed by a colon. Directly after the colon, enter the data (1 or 2 byte hexadecimal values only) separated by spaces. Then type a carriage return (refer to example 5).
2. Enter a colon followed by the data and type a carriage return. Data will be stored starting from the base address (refer to example 6).

### Examples:

1. Enter:           \*4000 ↵  
           Displayed:   4000-10

- Displays 1 byte of data from the specified address.

2. Enter:           \* ↵  
           Displayed:   \*20 30 50 60 70 80 90 9F

- Displays 8 bytes of data, starting from the base address.

3. Enter:           \*.4010A ↵  
           Displayed:   4008-A0 B0 C0 D0 E0 F0 00 10

4010-01 02 03 04 05 06 07 08

4018-12 34 56

- Displays all of the data from the base address to the specified address.

4. Enter: \*.3000 ↵

Displayed: 401B-78

- If the “period” address format is used and the entered address is lower than the base address, the contents of the specified address will not be displayed. The contents of the base address will be displayed instead.

5. Enter: \*3000:9 8 7 6 5 4 3 2 1 ↵

\*3000.3007 ↵

Displayed: 3000-09 08 07 06 05 04 03 21

- Pokes data in a series of addresses starting from the specified address.

6. Enter: \*:11 22 33 44 55 ↵

\*3000.3007 ↵

Displayed: 3000-11 22 33 44 55 04 03 21

- Pokes data in a series of addresses starting from the base address.

**Move Command**

Purpose: To transfer the data stored in a consecutive range of addresses to another place in memory

Format: M(destination start address)< (source start address). (source end address)

Remarks:

This command will transfer a block of data starting from (source start address) and ending at (source end address) to (destination start address). Note that the source address range must not overlap the destination address range; otherwise, the data will not be transferred correctly.

Example:

Enter: \*M3000<4000.4007 ↵

\*4000.4007 ↵

Displayed: 4000-01 02 03 04 05 06 07 08

Enter: \*3000.3007 ↵

Displayed: 3000-01 02 03 04 05 06 07 08

Example Remarks:

In the above example, the contents of addresses 4000 to 4007 are transferred to an address range starting at address 3000.

The following diagram illustrates correct and incorrect usage of the Move command.

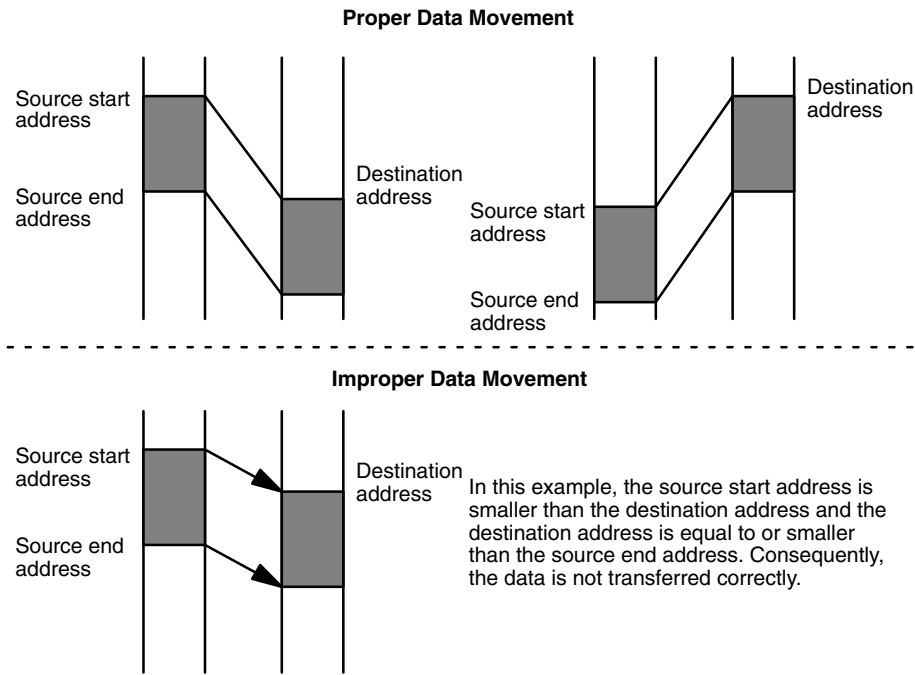

**Compare Command**

Purpose: To compare two blocks of data

Format: (start address 1)<(start address 2).(end address 2)

Remarks:

Compares the data stored from (start address 2) to (end address 2) to a block of data of the same size beginning at (start address 1). If the contents of the two address ranges differ, the corresponding address(es) where the data is not the same is displayed with its contents.

Example:

Enter: \*C3000<4000.4007 ↵

Displayed: 4003-FF (03)

Enter: \*3000.3007 ↵

Displayed: 3000-00 01 02 03 04 05 06 07

Enter: \*4000.4007 ↵

Displayed: 4000-00 01 02 FF 04 05 06 07

Example Remarks:

In the above example, data stored in addresses 3000 to 3007 is compared with data stored in addresses 4000 to 4007. In this example, the data stored in address 3003 has been found to differ from the data stored in address 4003. Consequently, the data stored in address 4003 (FF) and the data stored in address 3003 (03) are displayed.

**Register Command**

Purpose: To display or change the contents of a register.

Format: R(register) = (data)

(register) is one of the hardware registers: C, A, B, X, S, or P.

(data) is a one or two digit hexadecimal number.

Remarks:

If R is entered by itself, all of the registers and their contents will be displayed.

Examples:

1. Enter: \*R ↵

Displayed: C-C0 A-00 B-01 X-ABCD S-2EFF P-5000

- The contents of all the registers are displayed.

2. Enter: \*A=12 ↵

\*X=FF00 ↵

\*R ↵

Displayed: C-C0 A-12 B-01 X-FF00 S-2EFF P-5000

- The contents of the specified registers (A and X) are rewritten as specified.

## Break Point Command

Purpose: To set a breakpoint at a specified address

Format: BP[(address)]

Remarks:

Up to two breakpoints can be set at the same time. If BP is entered by itself, the current breakpoint(s) will be displayed. If BP is followed by an address, a new breakpoint will be set at that address.

Examples:

1. Enter: \*BP3000 ↵

- Sets a breakpoint.

2. Enter: \*BP ↵

Displayed: BP=3000

- Displays the currently set breakpoints.

3. Enter: \*BP5000 ↵

\*BP ↵

Displayed: BP=5000 3000

- Up to two breakpoints can be set.

## New Command

Purpose: To clear all breakpoints.

Format: N

Example:

Enter: \*N ↵

\*BP ↵

Displayed: BP=0000 0000

Example Remarks:

Clears all the breakpoints currently set.

**Disassembler Command**

Purpose: To disassemble and display 20 lines of code starting from the specified address.

Format: I(address)

Examples:

1. Enter: \*I 3000

Displayed: 3000-CE 10 00 LDX #\$1000  
 3003-FF 40 00 STX \$4000  
 3006-86 80 LDAA #\$80  
 . . .  
 3030-81 12 CMPA #\$12

- Disassembles and displays 20 lines of code starting from the specified address.

2. Enter: \*I, I ↵

Displayed: 3032-26 02 BNE \$3036  
 3034-A7 00 STAA \$00, X  
 3036-39 RTS  
 . . .  
 3080-08 INX

- Each time I,I is subsequently entered, the next 20 lines of code will be displayed.

**Save Command**

Purpose: To transfer the specified block of data to port 1 in S format

Format: S(start address).(end address)

Remarks:

Transfers the data stored from (start address) to (end address) in S format to the port 1 buffer.

Example:

Step 1: \*S3000.300F ↵

Step 2: Press the START/STOP switch.

Example Remarks:



The data stored from &H3000 to &H300F will be transferred to port 1. If a peripheral device other than the input terminal needs to be connected for the data transfer, follow the peripheral data transfer procedure explained at the beginning of this section.

### Load Command

Purpose: To load a data file in S format through port 1

Format: L[(offset)]

Examples:

1. Enter: \*L ↵

Enter: \*L100 ↵

Press the START/STOP switch.

- Loads a data file in S format through port 1 and stores the file in memory.

2. Enter: \*3100.310F ↵

Displayed: 3100-CE 00 00 08 26 FD 08 26

3108-FD 86 55 97 17 CE 00 00

- When an offset address is specified, the loaded file is stored in memory starting from an address whose value is the **specified address** plus the offset. Data transfer will not start until the ASCII Unit START/STOP switch is pressed.

### Verify Command

Purpose: To verify whether data sent through port 1 is the same as data stored in the specified memory locations

Format: V[(offset)]

Example:

Enter: \*V100 ↵

Press the START/STOP switch.

Displayed: 3120-12

Remarks:

The input data is compared with the data stored in the specified address range. The base address for data comparison is the **specified address** plus the offset.

If a discrepancy is found, the address at which it occurs and the data contained therein are both displayed. Data will not be verified until the ASCII Unit START/STOP switch is pressed.

If a peripheral device other than the input terminal needs to be connected for data transfer, follow the peripheral data transfer procedure explained at the beginning of this section.

### Go Command

Purpose: To execute a program

Format: G[(address)]

Example:

```

Enter:          *I3000 ↵
Displayed:      3000-86 80      LDAA      #$80
                3002-B7 40 00      STAA      $4000
                3005-20 F9      BRA       $3000

```

```

Enter:          *BP3005 ↵
                *G3000 ↵

```

Displayed: C-C8 A-80 B-FF X-0000 S-2EFF P-3005

Remarks:

If an address is specified, the user program is executed starting from that address. If no address is specified, execution will start from the address indicated by the program counter.

If program execution is aborted due to a breakpoint, SW1, or an interrupt, the register contents will be displayed.

If the stack pointer is not set to the assembly language area, this command will not execute correctly.

**Step Command**

Purpose: To execute a program one step at a time. This command is used for debugging.

Format: T[(address)]

Example:

```

Enter:          *T3000 ↵
Displayed:      3000-86 80      LDAA      #$80
                C-C8 A-80 B-00 X-0000 S-2EFF P-3002

```

Remarks:

When (address) is specified, the instruction stored starting at (address) is executed. If (address) is not specified, the instruction stored at the address indicated by the program counter is executed. To execute several program steps, execute the Step command as many times as required.

When Step is executed, the instruction stored at the specified address is displayed as well as the contents of all the hardware registers.

**Mini-Assembler**

Purpose: To assemble one line of the program at a time.

Procedure:

- 1, 2, 3...**
1. Key in CTRL+A
  2. Type in one line of code and a carriage return.
  3. To stop, key in X followed by a carriage return.

Remarks:

Keying-in CTRL+A puts the monitor in mini-assembler mode. Each time a line of code followed by a carriage return is subsequently entered, the mini-

assembler will assemble and display it. To exit mini-assembler mode enter "x" followed by a carriage return.

Example:

```
Enter:          *CTRL+A ↵
                !3000:LDA #$80 ↵
Displayed:      3000-86 80 LDAA  #$80
Enter:          ! LDAB #$7F ↵
Displayed:      3002-C6 7F  LDAB  #$7F
Enter:          ! STD  $4000 ↵
Displayed:      3004-FD 40 00 STD  $4000
Enter:          ! ASLA ↵
Displayed:      3007 48 ASLA
Enter:          ! BNE  $3000 ↵
Displayed:      3008 26 F6  BNE   $3000
Enter:          !X ↵
```

### Arithmetic Using Hexadecimal

Purpose: To add or subtract 4-digit hexadecimal data.

Format: (hex data)+(hex data)  
(hex data)-(hex data)

Examples:

```
Enter:          *1234+5678 ↵
Displayed:      1234+5678=68AC
Enter:          *ABCD+EF01 ↵
Displayed:      ABCD+EF01=9ACE
Enter:          *AB-12 ↵
Displayed:      AB-12=0099
```



# SECTION 6

## Program Examples

This section presents examples of data transfer routines written for both the PC and the ASCII Unit. In some cases, both a PC and an ASCII Unit Program are necessary for data transfer. In other cases only an ASCII Unit Program is necessary.

Both PC and ASCII Unit Programs necessary:

- Whenever the PC PUT or PC GET statements are used.
- Whenever the PC READ and PC WRITE statements are used without the Memory Area Designator (@).

Only ASCII Unit Program is necessary:

- Whenever the PC READ and PC WRITE statements are used with the Memory Area Designator (@).

In some of the program examples, there are two versions of the ASCII Unit Program; one runs in conjunction with a PC data transfer routine and the other runs independently of a PC program.

The purpose of the second part of this section is to give a step-by-step explanation of what the ASCII Unit and PC are doing during execution of their respective programs. This is presented under the heading “execution sequence.”

The last part of this section presents an Assembly Language program example.

Refer to *Appendix G Reference Tables* for a table listing all the program examples and their page numbers.

6-1	Example Programs . . . . .	80
6-2	Execution Sequence . . . . .	94
6-3	Assembly Language Example . . . . .	102

## 6-1 Example Programs

This section presents examples of data transfer routines written for both the PC and the ASCII Unit. The examples illustrate how the two programs work together to transfer data. Some of the examples have two ASCII Unit routines; the first one runs in conjunction with a PC routine and the second one runs independently of the PC and does not require a PC program.

Throughout this section, the following is assumed:

Unit no. : 0

Data area of PC: DM

### Example 1a

Purpose: To transfer data from the PC to the ASCII Unit using the PC READ statement

#### PC Program

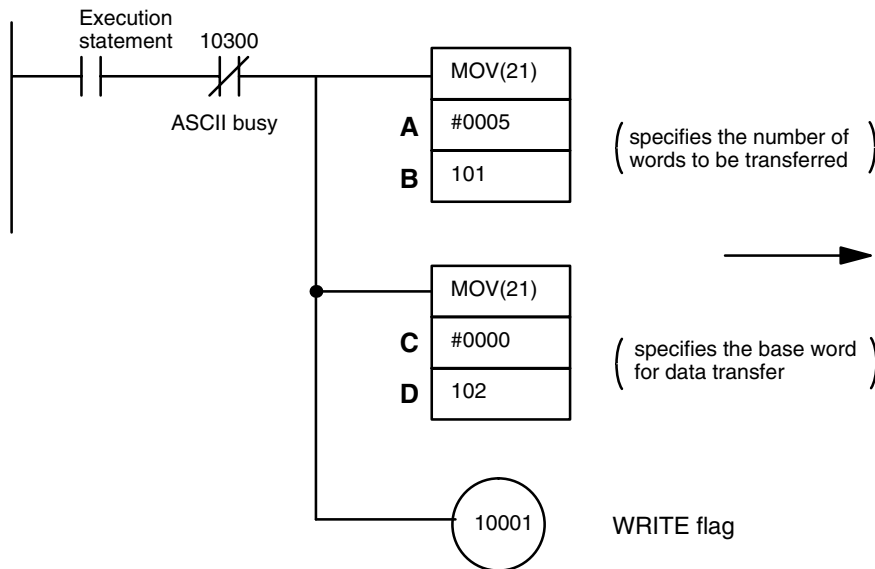

#### ASCII Unit Program

PC READ "5I4"; A,B,C,D,E

- |  |   |
|--|---|
| <b>A</b> Number of words to be transferred | <b>B</b> Word n+1                               |
| <b>C</b> Transfer base word (DM 0000)      | <b>D</b> Word n+2 (where n= 100 +10 x unit no.) |

#### Remarks:

In this example, when the execution statement flag is set, the data stored in words 0000 to 0004 is written to the ASCII Unit after the WRITE flag (word n bit 01) has been set.

When the ASCII Unit executes the PC READ statement, five specified words are read by the BASIC program, converted into BCD and assigned to the variables A through E. During execution of the PC READ statement, the ASCII Unit busy flag (word n+3 bit 00) is set. When execution is complete, the busy flag is cleared.

### Example 1b

Purpose: To use the ASCII Unit PC READ statement to specify and read data from the PC independently of the PC program

- This example does not require a PC data transfer routine.

ASCII Unit Program

PC READ "@D,0,5,5I4"; A,B,C,D,E

Remarks:

The above PC READ "@..." statement accesses the PC DM memory area when the user specifies "@D" as its first argument. When the ASCII Unit executes the above PC READ "@..." statement, five words are read by the BASIC program starting from DM word 0000, converted into BCD and assigned to the variables A through E. During execution of the PC READ "@..." statement, the busy flag (word n+3 bit 00) is set.

Example 2a

Purpose: To write data to the PC using the PC WRITE statement

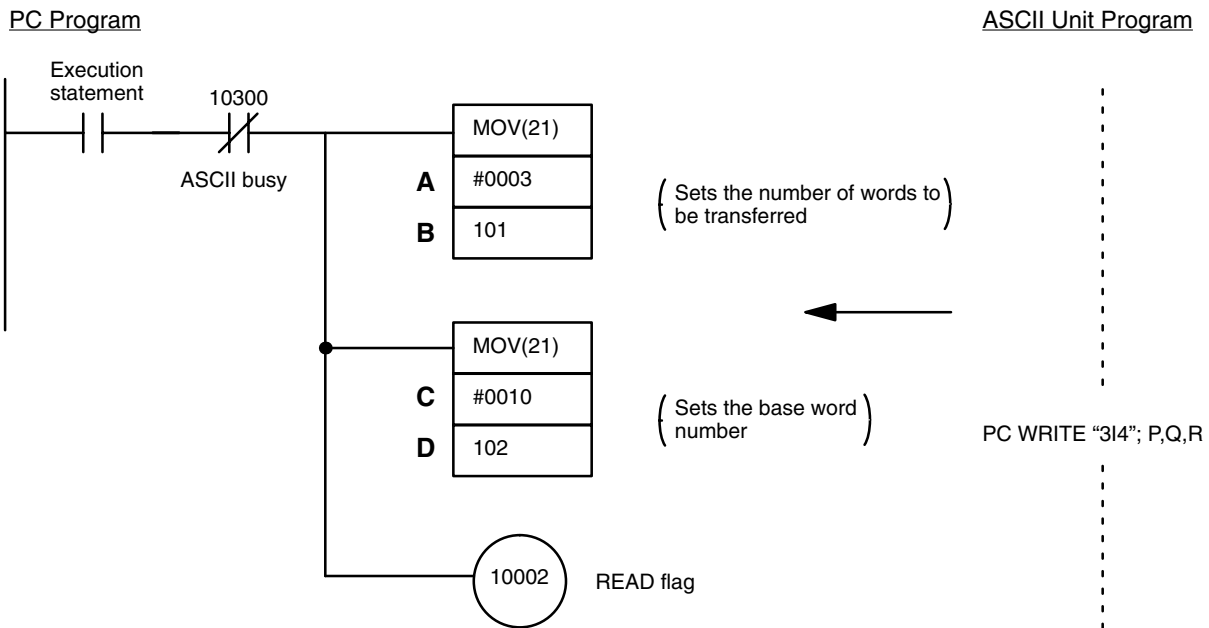

- A** Number of words to be transferred
- B** Word n+1
- C** Transfer base word (DM 0010)
- D** Word n+2 (where n = 100 + 10 x unit no.)

Remarks:

In the above program, when the execution statement flag is set, data is written to PC DM words 0010, 0011, and 0012 after the READ flag (word n bit 02) is set.

When the ASCII Unit executes the PC WRITE statement, variables P, Q, and R are converted into BCD and stored in the specified DM addresses.

During execution of the PC WRITE statement, the ASCII busy flag (word n+3 bit 00) is set. When execution is complete, the busy flag is cleared.

The PC WRITE statement is not executed until the PC READ flag is set.

Example 2b

Purpose: To use the ASCII Unit PC WRITE statement to specify and write data to the PC DM area independently of the PC program

- This example does not require a PC data transfer routine.

ASCII Unit Program

PC WRITE "@D,10,3,3I4";P,Q,R

Remarks:

When the ASCII Unit executes the PC WRITE “@...” statement, the variables P, Q, and R are converted into BCD and stored in DM words 0010, 0011, and 0012. During PC WRITE execution, the busy flag (word n+3 bit 00) is set.

Example 3

**Purpose:** To print data at fixed time intervals using the LPRINT statement

- This example does not require a PC data transfer routine.

ASCII Unit Program:

```

100 TH$ = MID$(TIME$,1,2)
110 IF TH$ = TH0$ GOTO 200
120 TH0$ = TH$
130 LPRINT TIME$,A
    
```

Remarks:

This program example prints a value (A) and the present time (TIME\$) on a printer every hour on the hour. The PRINT statement is executed when the “hours” change on the internal clock (for example, when the time changes from 9:59 to 10:00). The clock (24-hour) must be set prior to program execution.

Example 4a

**Purpose:** To transfer data from the keyboard to the PC using the BASIC “INPUT” statement

PC Program

ASCII Unit Program

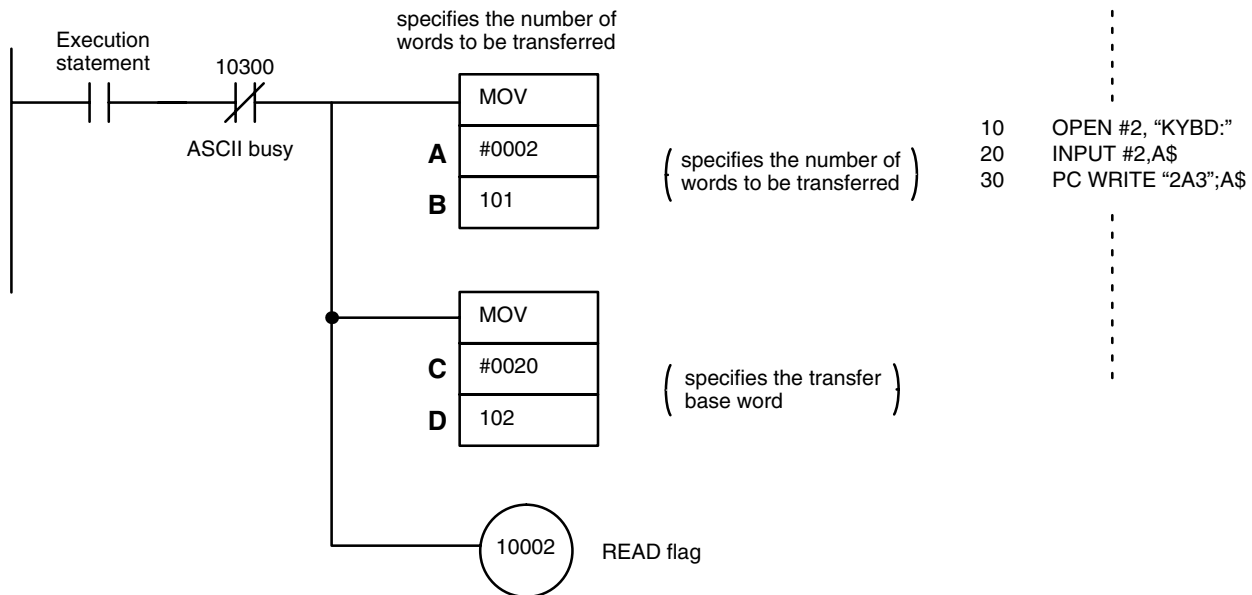

- A** Number of words to be transferred
- B** Word n+1
- C** Transfer base word (DM 0020)
- D** Word n+2 (where n = 100 +10 x unit no.)

Remarks:

In this example, “2A3” means that the low order byte of the first word and the high order byte of the second word are written.

In this example, data is entered from a keyboard connected to port 2 of the ASCII Unit and then written to the PC using the PC WRITE statement. Two



PC words are used to store the data, which consists of four characters (two characters per word).

When the execution statement flag is set, the data is stored in DM words 0020 and 0021.

The ASCII Unit OPENS port 2 as the keyboard, and stores the entered characters as a character string, A\$. The character string is terminated with a carriage return.

**Example 4b**

Purpose: To use the PC WRITE statement to specify and write data to the PC DM area

- This example does not require a PC data transfer routine.

ASCII Unit Program:

```

10 OPEN #2,"KYBD:"
20 INPUT #2,A$
30 PC WRITE "@D,20,2,2A3";A$
    
```

Remarks:

When the PC WRITE "@..." statement is executed, the first four characters of character string A\$ are converted into ASCII code and stored in DM words 0020 and 0021.

During PC WRITE "@..." execution, the busy flag (word n+3 bit 00) is set.

**Example 5**

Purpose: To control the ASCII Unit from the PC using the ON PC statement

PC Program

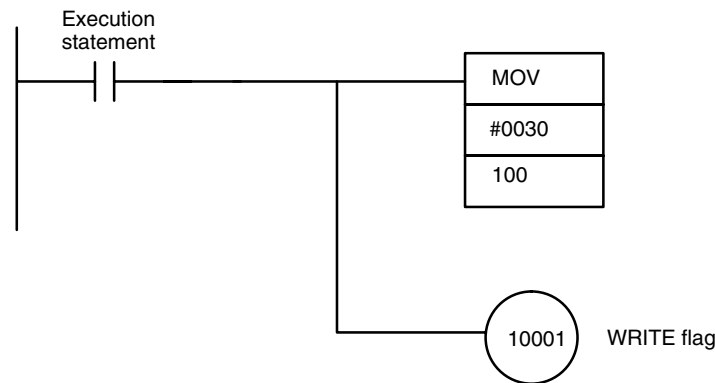

ASCII Unit Program

```

...
50 ON PC 3 GOSUB 200
60 ON PC 4 GOSUB 300
70 PC ON
...
200 A = 1234:RETURN
300 A = 2345:RETURN
...
    
```

Remarks:

In this example, the PC controls execution of the ASCII Unit by means of an interrupt.

When the ASCII Unit ON PC GOSUB statement is executed (the PC ON statement must be executed to enable the interrupts ) the PC can then interrupt the ASCII Unit. Each interrupt generated by the PC has a unique interrupt number associated with it. This number is written to the ASCII Unit Program and causes branching to a corresponding interrupt service routine. In the above example, the unique interrupt number is 3, causing a branch to line 200 of the BASIC program.

**Example 6**

Purpose: To direct execution of the ASCII Unit from the PC using the PC GET statement

Another way to externally control program execution is through polling. Polling is the process of continuously checking the value of a specified bit or word. If the value of the bit or word matches a condition set in the program, a corresponding branch instruction is executed.

In the following program, the ASCII Unit PC GET statement is used to poll a specific word of the PC.

PC Program

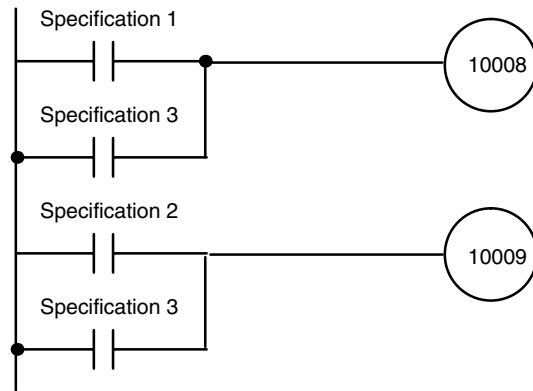

ASCII Unit Program

```

:
:
10  PC GET I, J
20  K = J AND 3
30  IF K = 1 GOTO 100
40  IF K = 2 GOTO 200
50  IF K = 3 GOTO 300
60  GOTO 10
:
:

```

Remarks:

The PC GET statement reads bits 10008 to 10015 of the PC as a word. The word is logically “ANDed” with 3 (00000011) and the result of this operation is used to branch the program. When bit 10008 is set, k will be equal to 1 and the program will branch to line 100. If bit 10009 is set, k will be equal to 2 and the program will branch to line 200.

**Example 7**

Purpose: To control execution of the PC from the ASCII Unit using the PC PUT statement

Using the PC PUT statement, the ASCII Unit can write data to word n+3 bits 08 through 15 of the PC. If the value of this data matches a condition set in the PC program, a corresponding branch instruction will be executed.

PC Program

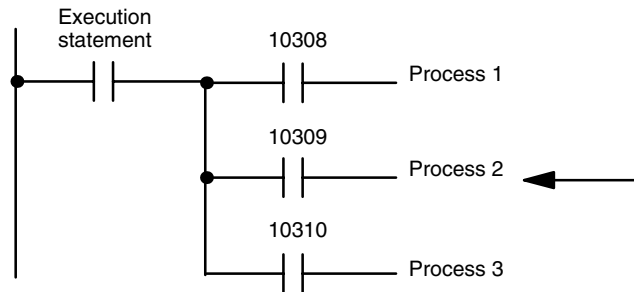

ASCII Unit Program

```

:
:
10  INPUT A
20  PC PUT A
:
:

```

Remarks:

In the above program, the ASCII Unit accepts external input from a keyboard using the INPUT statement and transfers that data to the PC with the PC PUT statement.

If the number "1" is input, bit 10308 of the PC is set, directing process (1) to be executed.

**Example 8a**

Purpose: To read and print PC data at specific times using the ASCII Unit PC READ statement

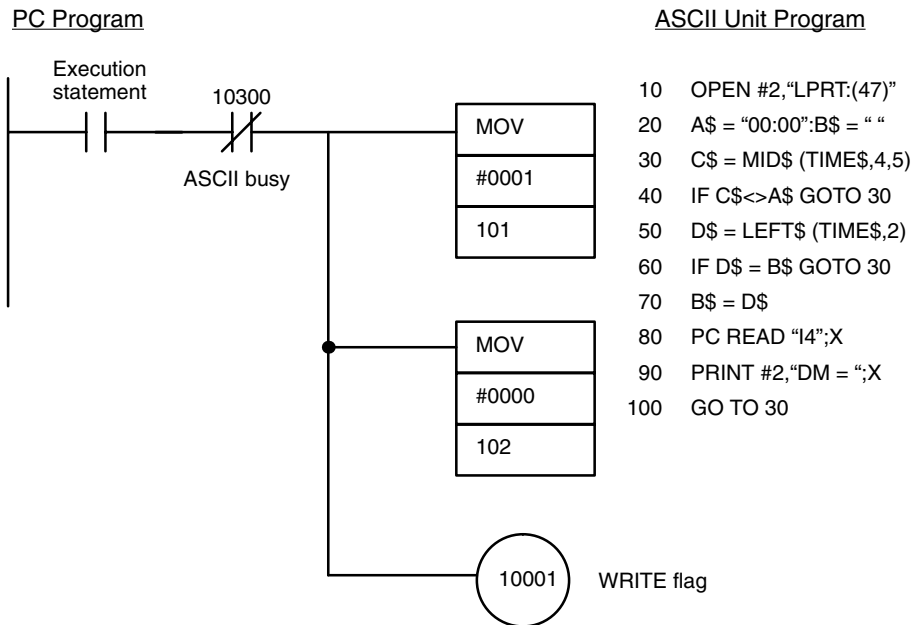

Remarks:

The printer should be connected to port 2. The baud rate should be set to 4,800 baud.

**Example 8b**

Purpose: To read and print PC data at specific times using the ASCII Unit PC READ(@...) statement

- This example does not require a PC data transfer routine.

ASCII Unit program:

```

10 OPEN #2,"LPRT:(47)"
20 A$ = "00:00":B$ = " "
30 C$ = MID$(TIME$,4,5)
40 IF C$<>A$ GOTO 30
50 D$ = LEFT$(TIME$,2)
60 IF D$ = B$ GOTO 30
70 B$ = D$
80 PC READ "@D,0,1,I4";X
90 PRINT #2,"DM = ";X
100 GO TO 30
    
```

**Example 9a**

Purpose: To accept input from the keyboard and write it to the PC using the PC WRITE statement

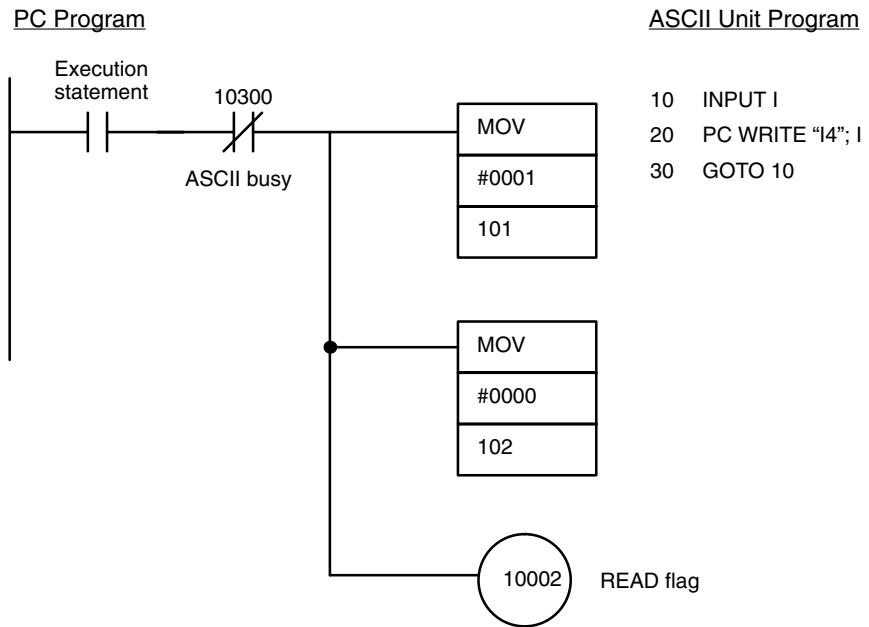

Remarks:

Product codes stored in DM memory are replaced by data input through a keyboard. The data is represented as 4-digit hexadecimal numbers.

**Example 9b**

Purpose: To accept input from the keyboard and write it to the PC using the PC WRITE(@...) statement

ASCII Unit Program:

```

10 INPUT I
20 PC WRITE "@D,0,1,I4";I
30 GOTO 10
    
```

**Example 10**

Purpose: To retrieve and print several types of data from the PC using the PC GET statement

PC Program

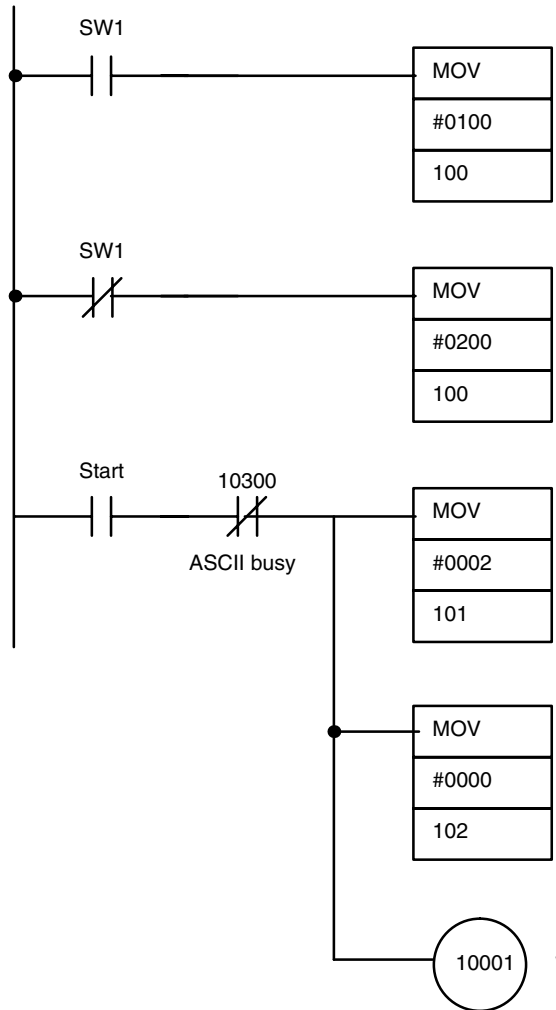

ASCII Unit Program

```

10 OPEN #2,"LPRT:(47)"
20 PC READ "214" ;X,Y
30 PC GET I, J
40 IF J = 1 THEN GOTO 100
50 IF J = 2 THEN GOTO 200
60 GOTO 30
...
100 PRINT #2,"DATA1 = ";X
...
200 PRINT #2,"DATA2 = ";Y

```

Remarks:

Two lot size areas, stored in PC DM words 0000 and 0001, are retrieved and printed.

Connect the printer to port 2 and set the baud rate to 4,800 bps.

Example 11

Purpose: To use PC interrupts to direct execution of the ASCII Unit

PC Program

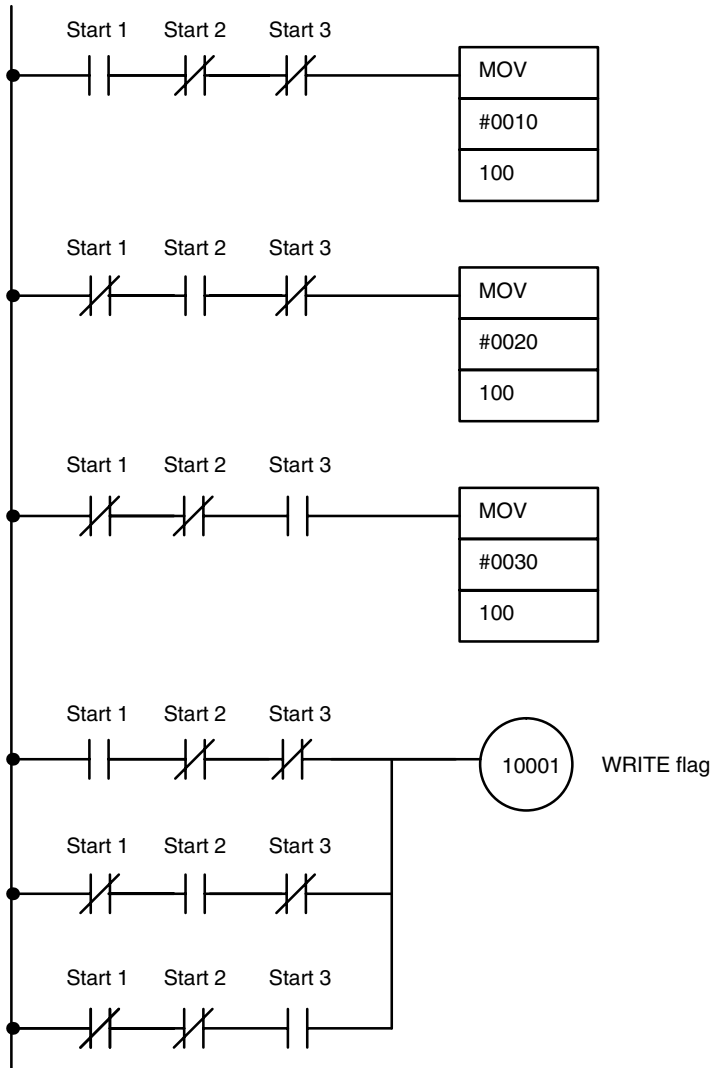

ASCII Unit Program

```

10 OPEN #2,"LPRT:(47)"
20 ON PC 1 GOSUB 100
30 ON PC 2 GOSUB 200
40 ON PC 3 GOSUB 300
50 PC ON
60 GOTO 60

70 PC READ "@D,0,1,I4";X1
80 PRINT #2,"DM0 = ";X1
90 RETURN

200 PC READ "@D,10,2,2I4";X1,X2
210 PRINT #2,"DM10 = ";X1
220 PRINT #2,"DM11 = ";X2
230 RETURN

300 PC READ "@D,100,3,3I4";X1,X2,X3
310 PRINT #2,"DM100 = ";X1
320 PRINT #2,"DM101 = ";X2
330 PRINT #2,"DM102 = ";X3
340 RETURN
    
```

Remarks:

Three ON PC GOSUB statements are used to direct program execution to three different interrupt service routines. After the branch destinations are defined by the ON PC GOSUB statements, the ON PC statement is executed enabling the interrupts. The statement "GOTO 60" at line 60 causes the program to wait for a PC interrupt to initiate further action.

If PC interrupt 1 interrupts the ASCII Unit, the contents of DM word 0000 will be printed. If PC interrupt 2 interrupts the ASCII Unit, the contents of DM words 0010 and 0011 will be printed. If PC interrupt 3 interrupts the ASCII Unit, the contents of DM words 0100, 0101, and 0102 will be printed.

Connect the printer to port 2 and set the baud rate to 4,800 bps.

The lot sizes are stored in DM words as follows:

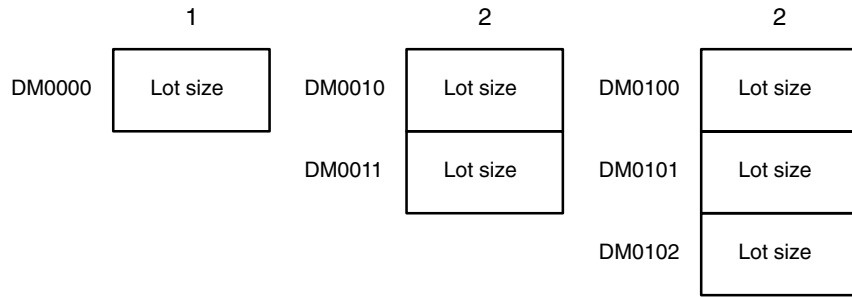

**Example 12**

Purpose: To print PC data and the time of data transfer

PC Program

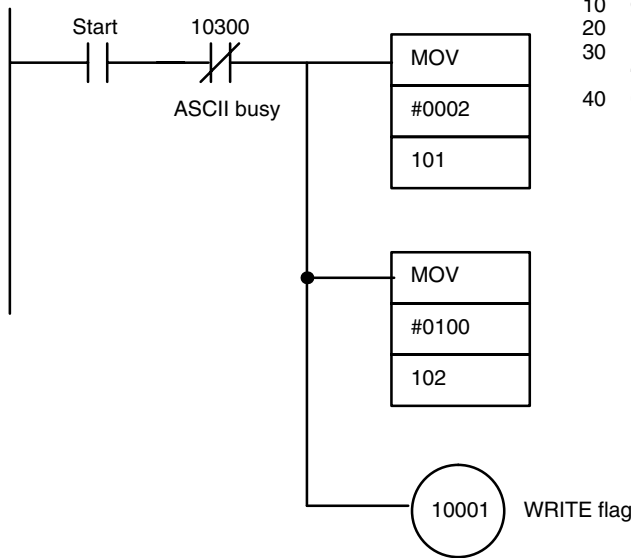

ASCII Unit Program

```

10 OPEN #2,"LPRT:(47)"
20 PC READ "214";D1,D2
30 PRINT #2,"DATA1 = ";D1,
  "DATA2=";D2,"TIME= ";TIME$
40 GOTO 20
    
```

Remarks:

PC data and the time of transfer are output to a printer connected to port 2 of the ASCII Unit. The PC read statement is used to obtain the data from the PC.

Output:

DATA1 = 5678	DATA2 = 9876	TIME = 13:45:03
DATA1 = 3249	DATA2 = 12	TIME = 14:02:51

**Example 13**

Purpose: To display the state of PC bit 1000 on a display device connected to port 2

- This example does not require a PC data transfer routine.

ASCII Unit Program:

```

10 OPEN #2,"SCRN:(40)"
20 PC READ "@R,10,1,B0";R
30 IF R = 0 THEN RS$ = "OFF"
   ELSE RS$ = "ON"
40 PRINT #2,"RELAY = ";RS$
    
```

Remarks:

The PC READ "@..." statement is used with "@R" as the first argument directing the read statement to obtain the data from the PC Relay memory area.

**Example 14**

Purpose: To input data from a bar code reader using the PC WRITE statement

Remarks: Connect the bar code reader to port 2.

The following figure defines the output format of the bar code reader.

STX	Data 1	Data 2	Data 3	Data 4	Data 5	Data 6	Data 7	Data 8	Data 9	Data 10	ETX
-----	--------	--------	--------	--------	--------	--------	--------	--------	--------	---------	-----

PC Program:

DM000	Data 1	Data 2
DM001	Data 3	Data 4
DM002	Data 5	Data 6
DM003	Data 7	Data 8
DM004	Data 9	Data 10

ASCII Unit Program :

```

10 OPEN #2,"COMU:(22)"
20 A$ = INPUT$ (1,#2)
30 IF A$ = CHR$(2) GOTO 50
40 GOTO 20
50 B$ = INPUT$(11,#2)
60 IF CHR$(3) = RIGHT$ (B$,1)
   THEN B$ = MID$(B$,1,10)
   ELSE GOTO 20
70 PC WRITE "@D,0,5,5A3";B$
80 GOTO 20
    
```

**Note** For details on the COMU statement, refer to the description of the OPEN statement in *Section 4-2-4 Device Control Statements*.

**Example 15**

Purpose: To read data from an input file through a com port

- This example does not require a PC data transfer routine.

ASCII Unit Program

```

10 CLEAR 1000
100 OPEN #1,"COMU:"
    
```



```

110 OPEN #2,"COMU:"
120 ON COM1 GOSUB 1000
130 ON COM2 GOSUB 2000
140 COM1 ON:COM2 ON
150 GOTO 150
1000 A = LOC(1)
1010 IF A<>0 THEN
    A$ = A$+INPUT$(A,#1)
1020 RETURN
2000 B = LOC(2)
2010 IF B<>0 THEN
    B$ = B$+INPUT$(B,#2)
2020 RETURN
    
```

**Example 16**

Purpose: To initiate data transfer with the START switch using the WAIT statement

PC Program

ASCII Unit Program

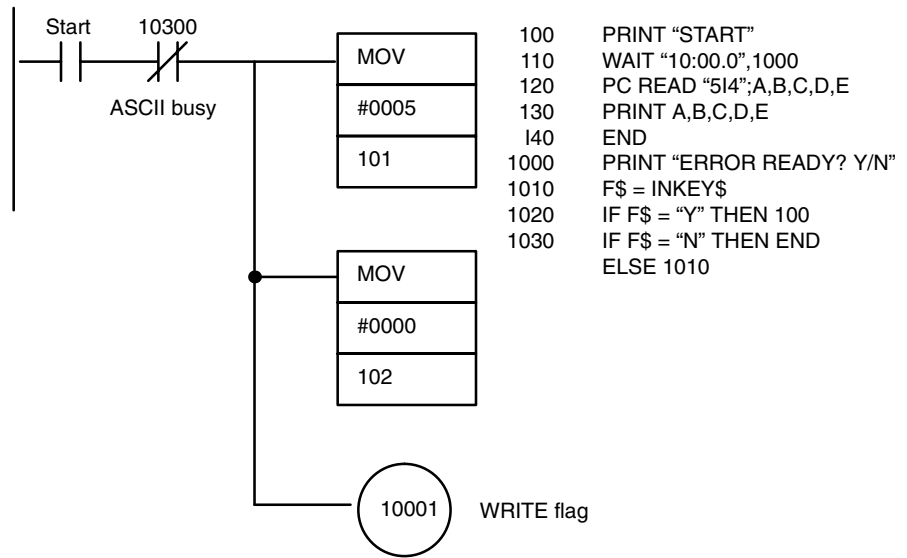

```

100 PRINT "START"
110 WAIT "10:00.0",1000
120 PC READ "5I4";A,B,C,D,E
130 PRINT A,B,C,D,E
140 END
1000 PRINT "ERROR READY? Y/N"
1010 F$ = INKEY$
1020 IF F$ = "Y" THEN 100
1030 IF F$ = "N" THEN END
    ELSE 1010
    
```

Remarks:

Pressing the PC START switch will cause specified PC data to be transferred to the ASCII Unit and displayed on the monitor. When the program is executed the message "Ready" will be displayed on the screen. If the START switch is not pressed within ten minutes, an error message will be displayed.

Example 17

Purpose: To direct processing using different interrupts

PC Program

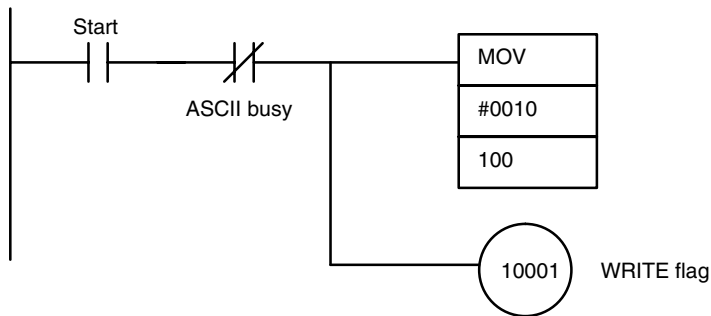

ASCII Unit Program

```

10 OPEN #1,"TERM:(42)"
20 OPEN #2,"COMU:(42)"
30 ON KEY 1 GOTO 100
40 ON KEY 2 GOTO 200
50 ON PC GOSUB 300
60 ON COM2 GOSUB 400
70 KEY ON:COM2 STOP
80 GOTO 80
100 'KEY 1 PROCESSING
110 COM2 ON:PC ON
120 GOTO 120
200 'KEY 2 PROCESSING
210 COM2 ON
220 IF A = 1 THEN GOSUB 300
230 GOTO 220
300 'PC INTERRUPT PROCESSING
310 B$ = MID$(STR$(LEN(A$)),2)
320 PC WRITE"@D,0,"+B$+" "+B$+"A3";A$
330 A = 0
340 RETURN
400 'COM INTERRUPT PROCESSING
410 IF EOF(2) THEN RETURN
420 A$ = INPUT$(LOC(2),#2)
430 A = 1
440 RETURN
    
```

Remarks:

In this example, a terminal is connected to port 1 and an RS-232C communication device is connected to port 2. Initially, all the interrupts are disabled. The program will wait for one of two inputs from the keyboard -- KEY 1 or KEY 2, each of which will direct the program to process subsequent interrupts in a unique way.

- 1, 2, 3... 1. If key 1 is pressed, the COM2 and PC interrupts will be enabled. When COM2 interrupts the ASCII Unit, a character is read from the communication device and assigned to the variable A\$. When the PC subsequently interrupts the ASCII Unit, the character will be written to the PC.
2. If key 2 is pressed, only the COM 2 interrupt is enabled. When COM 2 interrupts the ASCII Unit, the data is read and written directly to the PC.

Example 18

**Purpose:** In this example, the PC initiates the transfer of ASCII data from the PC to the ASCII Unit on the Remote I/O Unit.

PC Program Using the READ Instruction

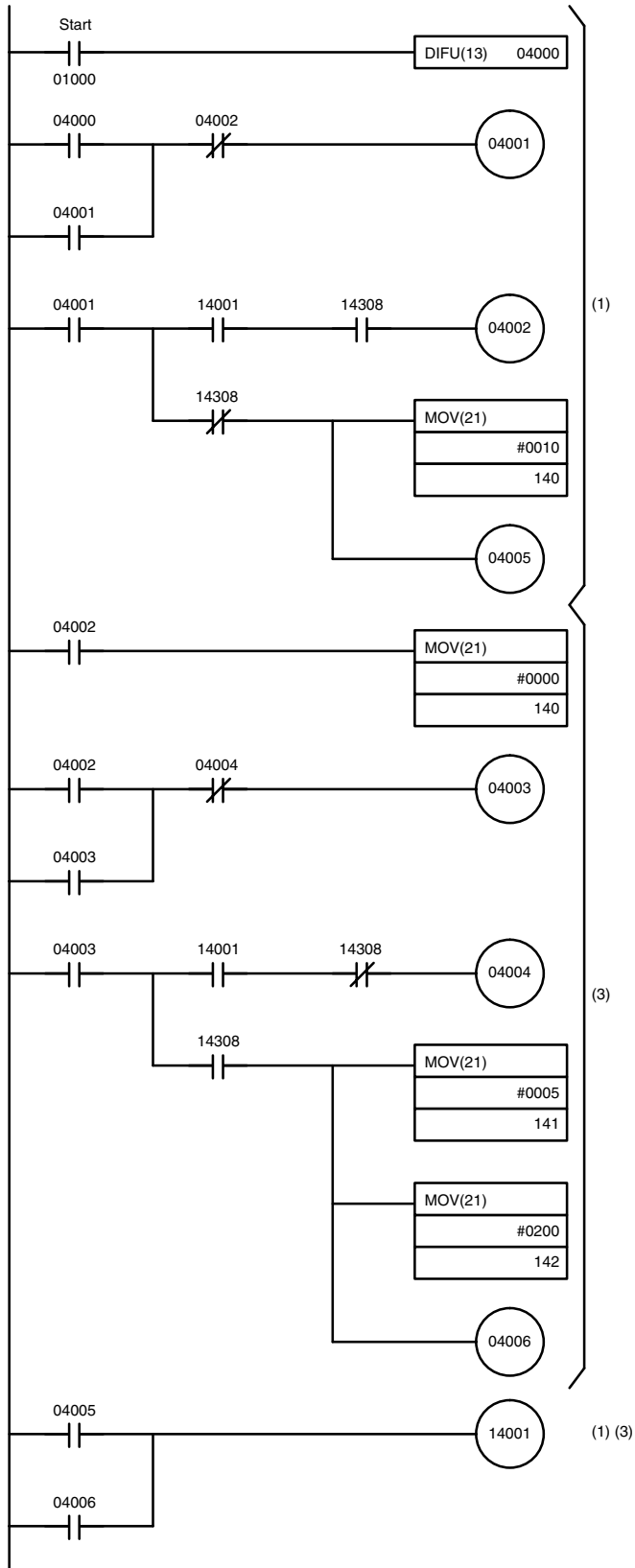

ASCII Unit Program

```

10 PC PUT 0
20 ON PC 1 GOSUB 100
30 PC 1 ON
40 GOTO 40
100 PC PUT 1
110 FOR I = 1 TO 50: NEXT 1
120 PC READ "514"; A1, A2, A3, A4, A5
130 PRINT A1, A2, A3, A4, A5
140 PC PUT 0
150 RETURN
    
```

**Note:** The time required to complete the 110 PC PUT transfer and to turn OFF the WRITE flag must be adjusted according to the PC scan time and remote scan time.

## 6-2 Execution Sequence

This section presents several additional programs with the emphasis on explaining the actions of the PC and the ASCII Unit during execution of their respective programs.

### Example 1a

Purpose: To transfer data from the PC to the ASCII Unit with the ASCII Unit maintaining control

PC Program

ASCII Unit Program

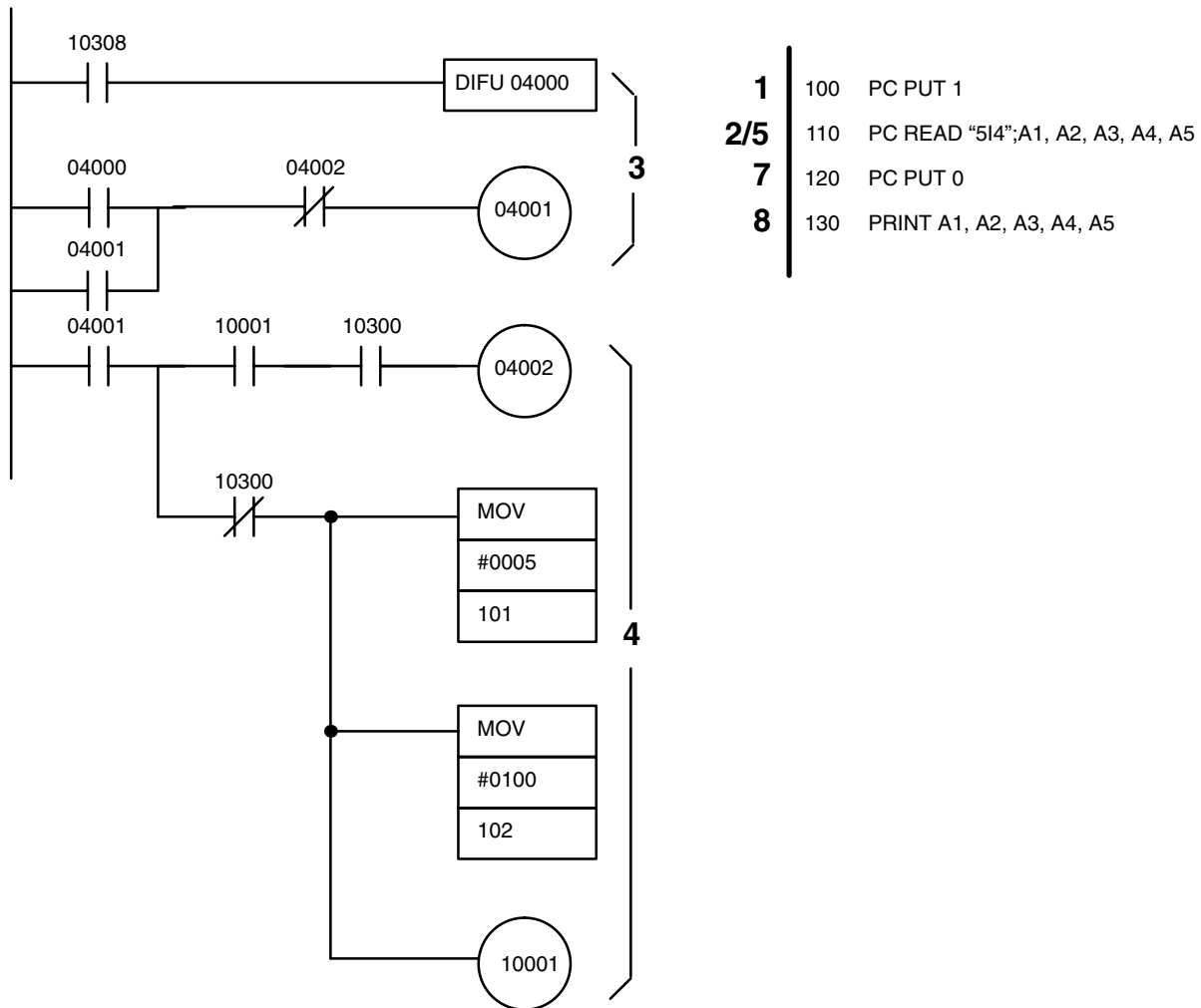

Execution Sequence:

- 1, 2, 3... 1. ASCII: The PC PUT 1 statement sets bit 10308
2. ASCII: Executes the PC READ statement
3. PC: The self-holding circuit is set on the positive edge transition of bit 10308.
4. PC: Sets the transfer base word number and the number of words to be transferred to the ASCII Unit when contact 04001 is set and sends the data to the ASCII Unit when the WRITE flag (10001) is set.
5. ASCII: Sets the BUSY flag (10300) when the data has been received.
6. PC: Clears the WRITE flag when the BUSY flag is set and the ASCII Unit starts transferring the data. It also clears the self-holding circuit (04001).

7. ASCII: After transferring the data, clears bit 10308 with PC PUT 0 and waits for more data.
8. ASCII: Displays the read data.

**Example 1b**

Purpose: To transfer data from the PC to the ASCII Unit with the ASCII Unit maintaining control

- This example does not require a PC data transfer routine.

ASCII Unit Program:

```

100 PC READ"@D,100,5,5I4";A1,A2,A3,A4,A5
110 PRINT A1,A2,A3,A4,A5
    
```

Execution Sequence:

- 1, 2, 3... 1. ASCII: Reads data using the PC READ "@..." statement independently of the PC program.
2. ASCII: Displays the data read in step (1).

**Example 2a**

Purpose: To transfer data from the ASCII Unit to the PC with the ASCII Unit maintaining control

PC Program

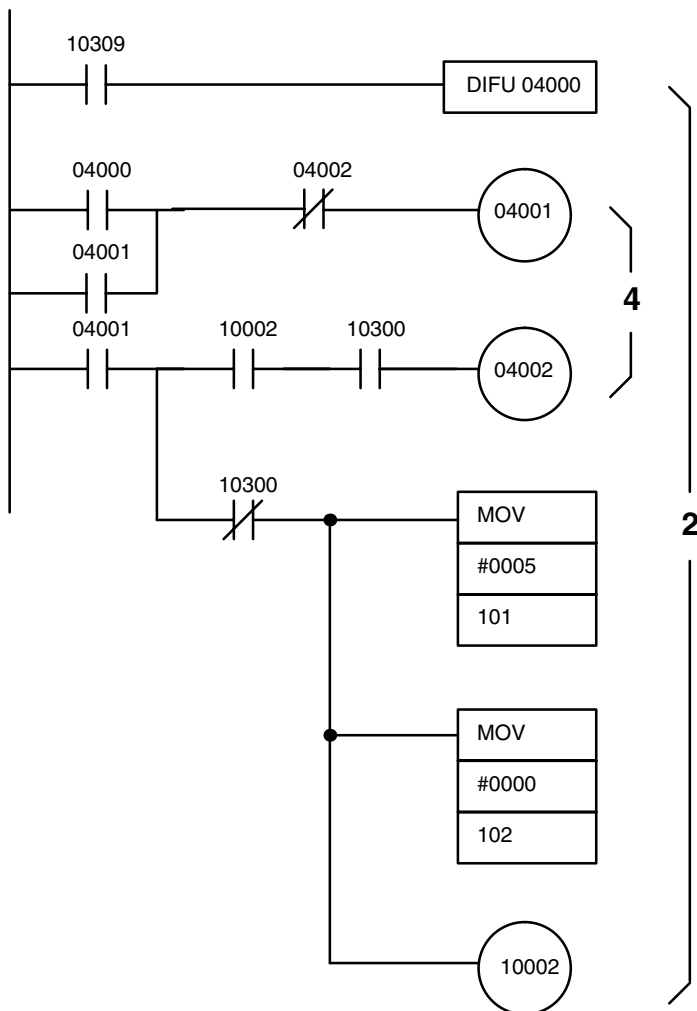

ASCII Unit Program

```

1 { 100 PC PUT 2
   110 PC WRITE "5I4";A1,A2,A3,A4,A5
3 130 PC PUT 0
    
```

Execution Sequence:

- 1, 2, 3...**
1. ASCII: Sets bit 10309 with the PC PUT 2 statement. Executes the PC WRITE statement and waits until the program is started from the PC.
  2. ASCII: Executes the PC WRITE statement after bit 10309 has been set.
  3. ASCII: Sets bit 10390 with the PC PUT 0 statement after the PC WRITE statement has been executed.
  4. PC : Sets the self-holding circuit (04001) after the PC WRITE statement has been executed (i.e., after the ASCII busy flag (10300) has been cleared).

Remarks:

If this program is executed repeatedly, and if the time required to set bit 10309 with PC PUT 2 after it has been cleared with PC PUT 0 is longer than the scan time of the PC, the PC cannot detect the state of bit 10309.

**Example 2b**

Purpose: To transfer data from the ASCII Unit to the PC with the ASCII Unit maintaining control.

- This example does not require a PC data transfer routine.

ASCII Unit Program:

```
100 PC WRITE "@D,0,5,514";A1,A2,A3,A4,A5
110 END
```

Example 3a

Purpose: To transfer data from the PC to the ASCII Unit with the PC maintaining control.

PC Program

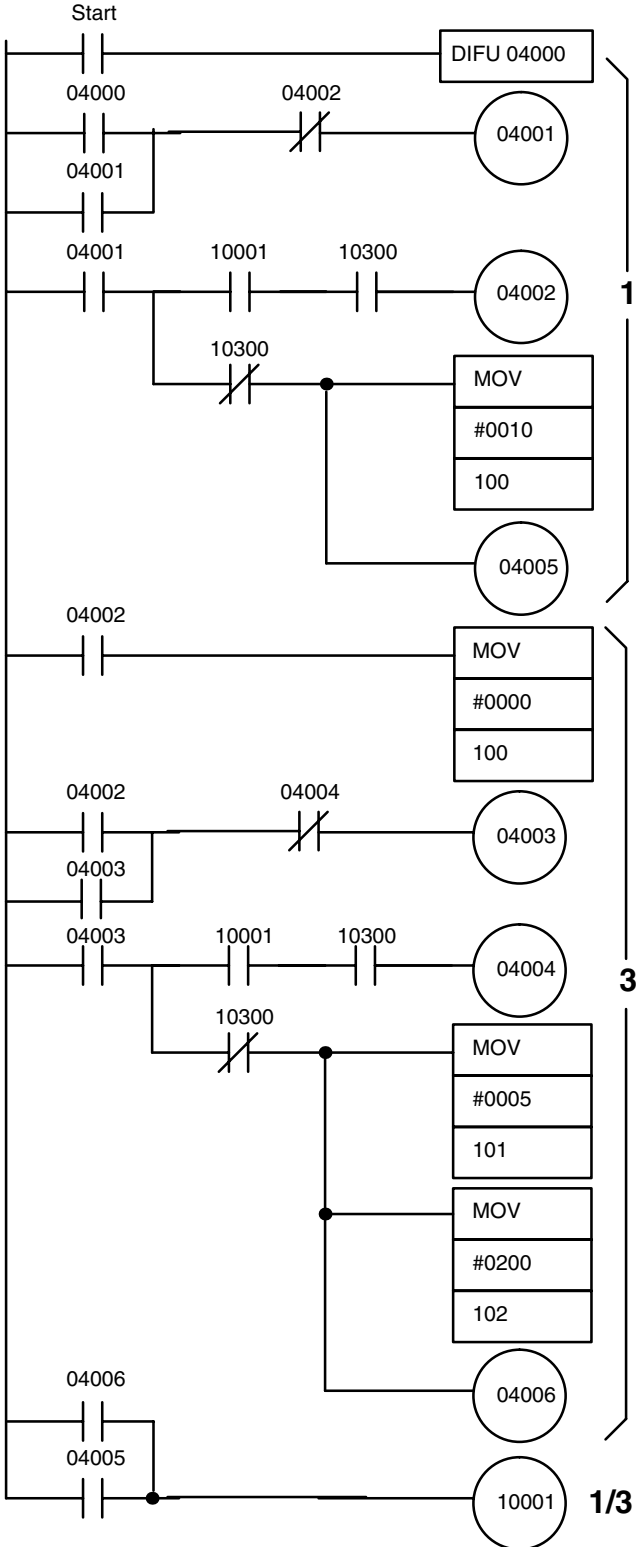

ASCII Unit Program

```

10 ON PC 1 GOSUB 100
20 PC 1 ON
30 (ordinary processing)
   ⋮
90 GOTO 30
2 { 100 PC READ "514";A1,A2,A3,A4,A5
    110 PRINT A1,A2,A3,A4,A5
    120 RETURN

```

Execution Sequence:

- 1, 2, 3... 1. PC: The self-holding circuit is set on the positive edge transition of bit 04001. An interrupt number is then generated for execution of the ON PC 1 GOSUB statement, and the WRITE flag (10001) is set.
2. ASCII: Branches to an interrupt service routine (statements 100 to 120) when the interrupt from the PC is enabled by the ON PC statement, and then waits until the PC READ statement is processed by the PC.
3. PC: Sets interrupt number 0 when the interrupt enabled by the ON PC statement is being processed (i.e., when the ASCII busy flag (10300) has been set) and disables all other interrupts. Also specifies the PC READ parameters, sets the WRITE flag (10001), and initiates processing of the PC READ statement.
4. ASCII: Executes the PC READ statement on direction from the PC and displays the data. Processing then returns to the main routine and the ASCII Unit waits for the next interrupt.
5. PC: Returns to its initial status after execution of the PC READ statement (i.e. when the ASCII busy flag (10300) has been cleared).

**Example 3b**

Purpose: To transfer data from the PC to the ASCII Unit with the PC maintaining control

PC Program

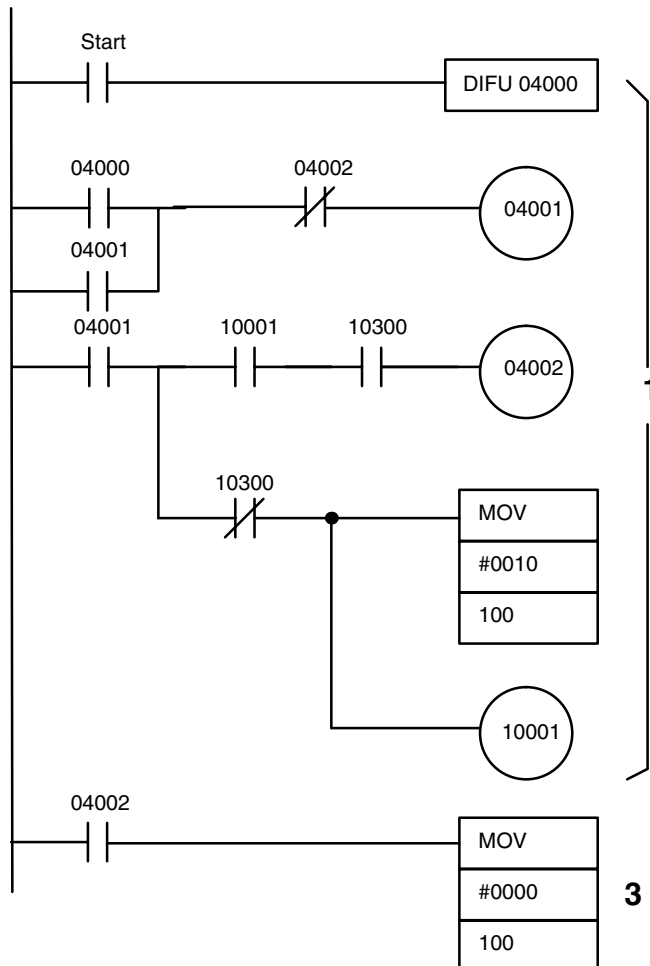

ASCII Unit Program

```

10 ON PC 1 GOSUB 100
20 PC 1 ON
30 (ordinary processing)
   ⋮
90 GOTO 30
2 100 PC READ "@D,200,5,5I4,";A1,A2,A3,A4,A5
110 PRINT A1,A2,A3,A4,A5
120 RETURN
    
```



Execution Sequence:

- 1, 2, 3... 1. PC: The self-holding circuit (04001) is set on the leading edge of the start statement pulse. The PC then sets an interrupt number and sets the WRITE flag (10001).
2. ASCII: Branches to an interrupt routine (statements 100 to 120) after the interrupt is enabled by the ON PC statement and then reads the data with the PC READ "@..." statement.
3. PC: Changes the interrupt number to 0 to disable further interrupts after all the data has been transferred to the ASCII Unit (i.e. when the ASCII busy flag (10300) has been cleared).

**Example 4a**

Purpose: To transfer data from the ASCII Unit to the PC with the PC maintaining control

PC Program

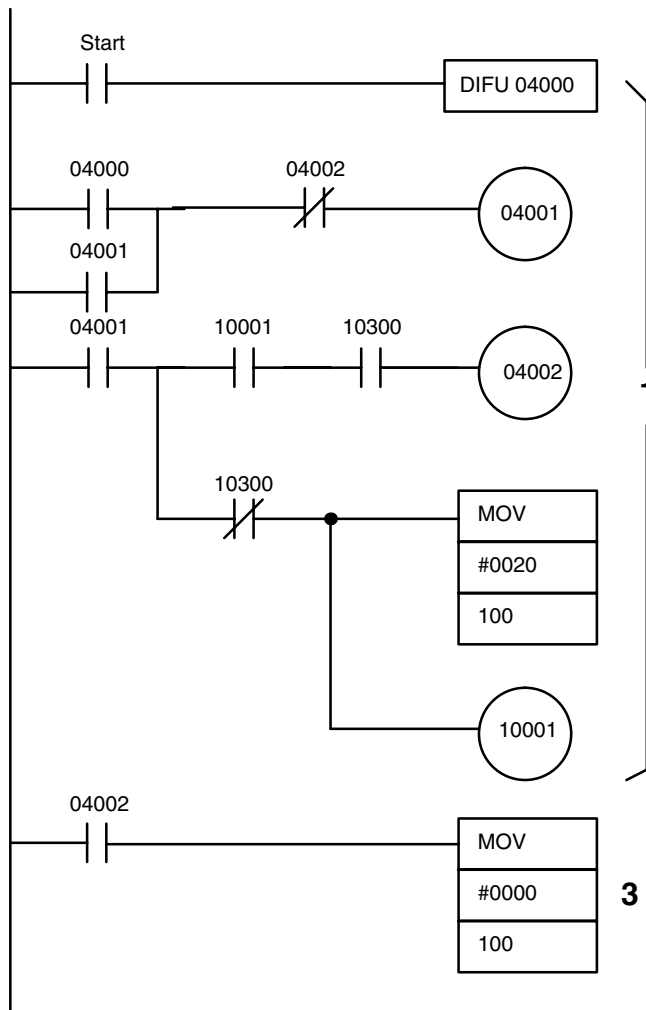

ASCII Unit Program

```

10 ON PC 2 GOSUB 100
20 PC 2 ON
30 (ordinary processing)
   ...
40 GOTO 30
2 | 100 PC WRITE "@D,400,5,5I4,";A1,A2,A3,A4,A5
   | 110 PRINT A1,A2,A3,A4,A5
   | 120 RETURN

```

Execution Sequence:

- 1, 2, 3... 1. PC: The self-holding circuit (04001) is set on the leading edge of the start statement pulse. The PC then sets an interrupt number and sets the WRITE flag (10001).
2. ASCII: Branches to an interrupt routine (statements 100 to 120) after the interrupt has been enabled by the ON PC statement and then writes data to the PC with the PC WRITE "@..." statement.

3. PC: Changes the interrupt number to 0 to disable further interrupts after the data has been transferred from the ASCII Unit (i.e. when the ASCII busy flag (10300) has been turned OFF).

**Example 4b**

Purpose: To transfer data from the ASCII Unit to the PC with the PC maintaining control

PC Program

ASCII Unit Program

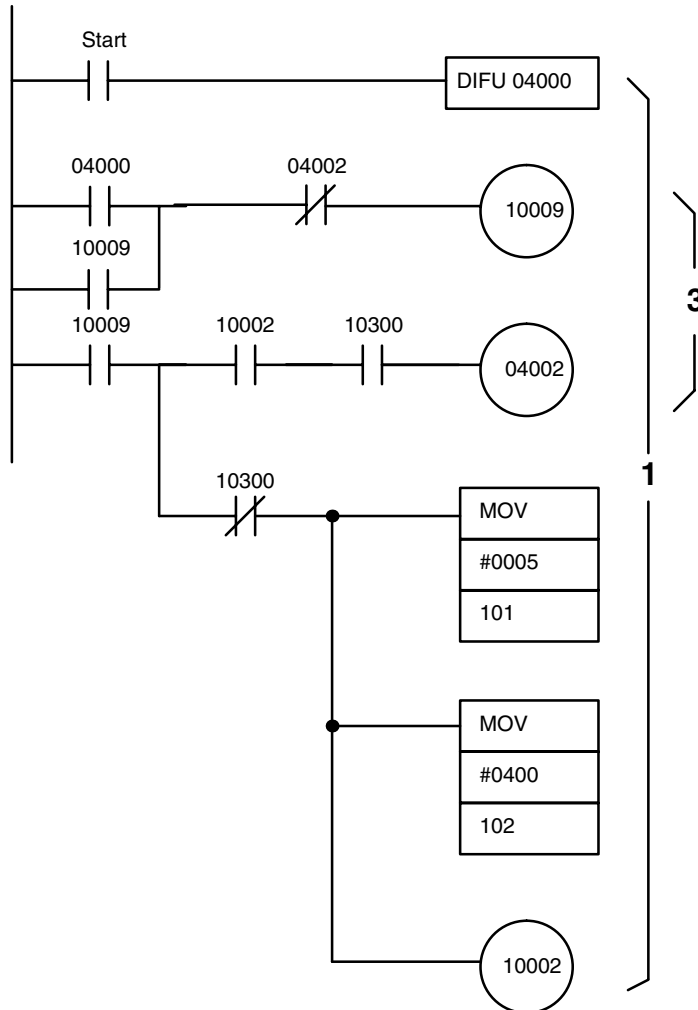

```

100 PC GET I,J
110 K=J AND 2
2 120 IF K<>2 THEN 100
130 PC WRITE "5I4";A1,A2,A3,A4,A5
140 END
    
```

Execution Sequence:

- 1, 2, 3... 1. PC: The self-holding circuit (10009) is set on the leading edge of the start statement signal. The WRITE flag is then set to initiate execution of the PC WRITE statement.
2. ASCII: Executes the PC WRITE statement
3. PC: Clears the self-holding bit after the PC WRITE statement has been executed (i.e. when the ASCII busy flag (10300) has been cleared).

**Example 5**

Purpose: To process data with the ASCII Unit

PC Program

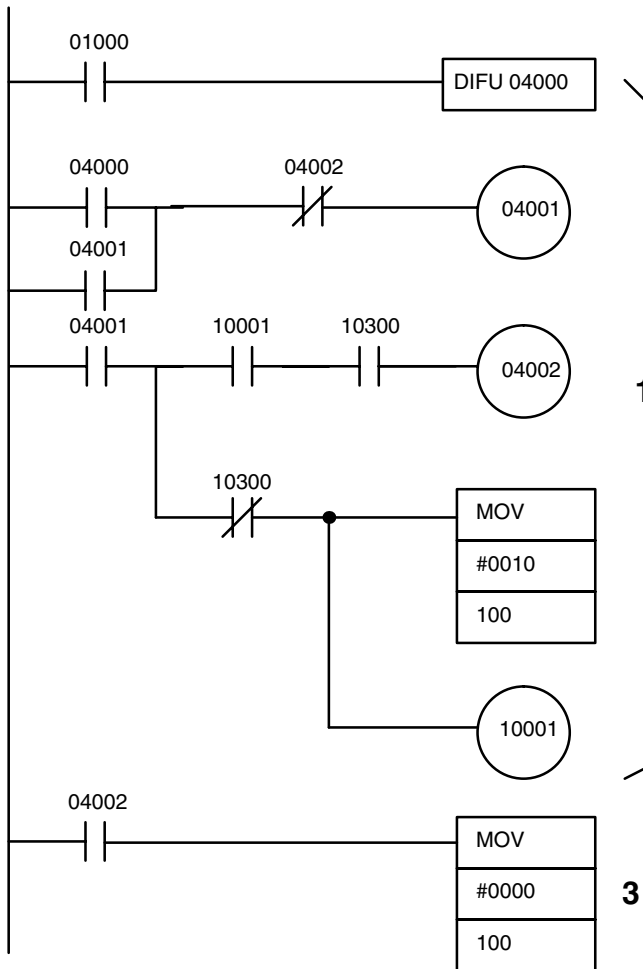

ASCII Unit Program

```

100 ON PC 1 GOSUB 1000
110 PC 1 ON
    ⋮
4 190 GOTO 190

1000 PC READ "@D,100,10,10H4";A1 ... A10
1010 (computation processing)
    assigns the results to B1 through B15
    ⋮
2 1100 PC WRITE "@D,200,15,15H4";B1 ... B15
1110 RETURN
    
```

Remarks:

This program transfers 100 words of data from the PC to the ASCII Unit (starting from PC DM word 0100) each time bit 01000 is set. The ASCII Unit performs some calculations with the data and the results are sent back to the PC and stored in DM words 0200 to 0214.

Execution Sequence:

- 1, 2, 3... 1. PC: The self-holding circuit (04001) is set on the positive edge transition of bit 01000. An interrupt number is then generated for execution of the the ON PC 1 GOSUB statement and the WRITE flag (10001) is set.
2. ASCII: After the interrupt is enabled with the ON PC statement, execution branches to an interrupt service routine (statements 1000 to 1110) and the specified PC data is read and assigned to variables A1 to A10 by the PC READ "@..." statement. Computations are then performed on the data and the results are assigned to variables B1 through B15. These results are then transferred back to the PC with the PC WRITE "@..." statement.
3. PC: After the ON PC GOSUB statement is executed, the interrupt number is set to 0 disabling further interrupts (i.e., when the ASCII busy flag (10300) has been turned OFF).

4. ASCII: Exits the interrupt service routine and waits for the next interrupt.

**Example 6**

Purpose: To process data using the PC

Remarks:

In this example, data is entered through the ASCII Unit keyboard and transferred to the PC. The PC performs some computations on the data and then sends it back to the ASCII Unit.

PC Program

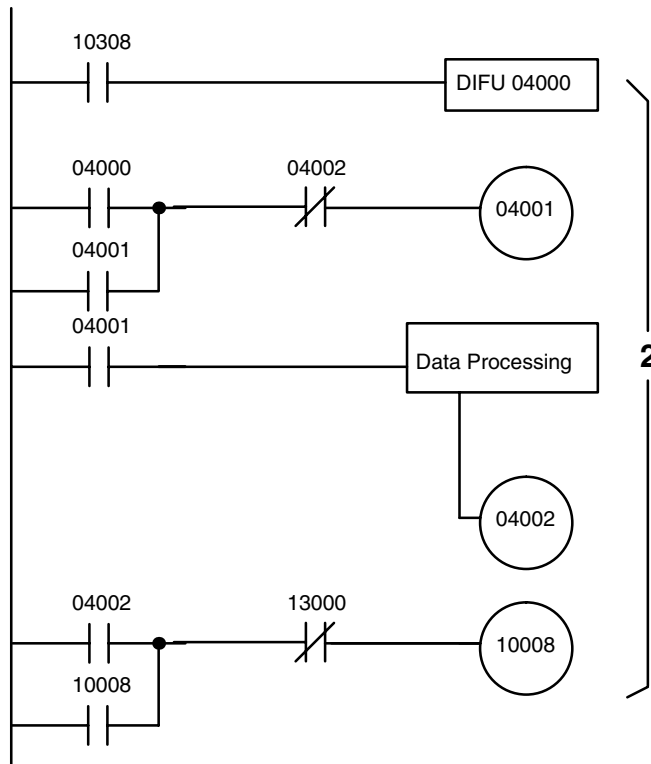

ASCII Unit Program

```

100 PC PUT 0
110 INPUT A,B,C
120 PC WRITE "AD,100,3,3I4"; A1,A2,A3
130 PC PUT 1
140 PC GET I,J
150 K=J AND 1
160 IF K<>1 THEN I40
170 PC READ ":D,200,4,4I4"; B1,B2,B3,B4
180 PRINT B1,B2,B3,B4
190 GOTO 100
    
```

Execution Sequence:

- 1, 2, 3... 1. ASCII: The PC is initialized with the PC PUT 0 statement. Data is entered via the keyboard and read with the INPUT statement. The data is then written to the PC with the PC WRITE "@..." statement. PC processing is then initiated with the PC PUT 1 statement.
2. PC: When data processing is complete, the self-holding circuit (10008) is set requesting the ASCII Unit to read the processed data.
3. ASCII: Polls PC bit 10008, waiting for it to be set (it is set when data processing is complete) and then reads the data with the PC READ "@..." statement. The data is then displayed.

## 6-3 Assembly Language Example

This section presents an assembly language program that is called from a BASIC program running on the ASCII Unit.

BASIC Program:

```

100 DEF USR0=&H2000
110 INPUT A$
120 A$=USR0(A$)
    
```

```

130 PRINT A$
140 END
    
```

Procedure;

- 1, 2, 3...**
1. Use MSET &H3000 to reserves an assembly language program area.
  2. Key-in MON to initiate assembly language monitor mode.
  3. Key-in CTRL+A <- Sets mini-assembler mode.
  4. Key-in the program sequentially from \$2000.
  5. Key-in CTRL+B after the program has been input to return to BASIC mode.

The following memory areas are used as a program area, work area, and buffer area respectively:

**Program Area**

Address	Area
\$2000 to \$24FF	Program area
\$2500 to \$2507	Work area
\$2600 to \$27FF	Buffer area

**Work Area**

Address	Function
\$2500 to \$2501	Stores buffer 1 (stores numerals) pointer
\$2502 to \$2503	Stores buffer 2 (stores characters) pointer
\$2504 to \$2505	Stores transfer source word
\$2506 to \$2507	Stores transfer destination word

**Buffer Area**

Address	Area
\$25600 to \$26FF	Numeral storage area
\$2700 to \$27FF	Character storage area

Assembly language program operation:

The numbers and characters are separated and stored in the number storage buffer and the character storage buffer, respectively. Then numeric strings and character strings are restored as the original character variables. This program has no practical application; it is an example only.

**Assembly Program**

```

$2000 PSHA           Saves registers
      PSHB
      PSHX
      LDD  #$2600    Sets first address of buffer 1 in pointer 1
      STD  $2500
      LDD  #$2700    Sets first address of buffer 2 in pointer 2
      STD  $2502
      LDAB 0,X       Number of characters to GET
      LDX  1,X       Character variable first address GET
      STX  $2504
$2016 LDX  $2504     DOUNTIL (number of times equal to the number of characters)
      LDAA 0,X       Character GET
      INX          Character variable address pointer + 1
      STX  $2504
      CMPA #$30     IF ($30 min.)
      BLT  $2032    THEN
      CMPA #$39     IF (numeral less than $39)
      BHI  $2032    THEN
      LDX  $2500     Stores numeral in buffer 1
      STAA 0,X
      INX
      STX  $2500
      BRA  $203B
$2032 LDX  $2502     ENDIF
      STAA 0,X       Stores character in buffer 2
      INX
      STX  $2502
$203B DECB         Updates counter
      BNE  $2016    ENDDO
      LDD  $2500
      LDX  #$2600    Transfer from buffer 1 to a character variable
      STX  $2504
    
```

```
PULB
    PULX
    PSHX
    LDX  1,X
    ABX
    STX  $2506
    LDD  $2502
    SUBD #$2700
    JSR  $2100
    PULX
    PULB
    PULA
    RTS
$2100 LDX  $2504
    LDAA 0,X
    INX
    STX  $2504      Data transfer subroutine
    LDX  $2506
    STAA 0,X
    INX
    STX  $2506
    DECB
    BNE  $2100
    RTS
```





## Appendix A Standard Models

Item	Description	Model No.
ASCII Unit	EEPROM	C200H-ASC02
Battery Set	Backup battery for C200H only	C200H-BAT09



# Appendix B

## Specifications

### Specifications

Item	Specifications
Communication mode	Half duplex
Synchronization	Start-stop
Baud rate	Port 1: 300/600/1,200/2,400/4,800/9,600 bps Port 2: 300/600/1,200/2,400/4,800/9,600/19,200 bps
Transmission mode	Point-to-point
Transmission distance	15 m max.
Interface	Conforms to RS-232C. Two ports (D-sub 9P connectors) (see note)
Memory capacity	BASIC program area and BASIC data area: 24K bytes (RAM) (memory is protected by built-in battery backup) BASIC program storage area: 24K bytes (EEPROM) The program memory area can be segmented into 3 program areas
Transfer capacity	255 words at a maximum of 20 words per scan
Timer function	Year, month, day, date, hour, minute, second (leap year can be programmed) Accuracy: month $\pm$ 30 seconds (at 25°C)
Diagnostic functions	CPU watchdog timer, battery voltage drop
Battery life	5 years at 25°C. (The life of the battery is shortened if the ASCII Unit is used at higher temperatures.)
Internal current consumption	200 mA max. at 5 VDC
Dimensions	130(H) x 35(W) x 100.5(D) mm
Weight	400 grams max.

**Note** Redundant output may occur at ports during initialization at startup. Take steps to ensure that this output is ignored at connected devices (e.g., by clearing received data).

## Rear Panel

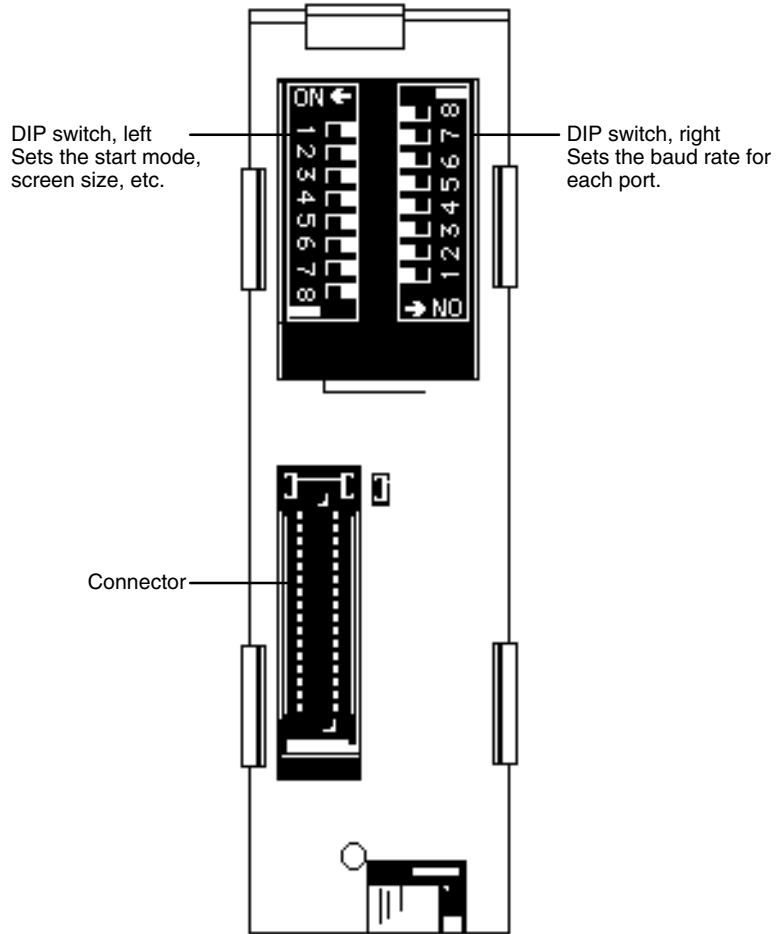

## Left-Side DIP Switch

Pin No.	Function	Description
1	Start mode	Sets automatic or manual mode for start-up of a BASIC program upon power application.
2	Automatic program transfer from EEPROM to RAM	Specifies whether the BASIC program is automatically transferred from the EEPROM to RAM on power application or reset.
3	Program No.	Sets the program number. The program number can be changed by the PGEN command.
4		
5	Data Section mode selector	Sets the Data Section to either two-word or four-word mode
6	Screen size	Sets the screen size of the input device
7		
8		

## Right-Side DIP Switch

Pin No.	Function	Description
1	Baud rate for port 1	Sets the baud rate for port 1.
2		
3		
4	Not used	Always set this pin to OFF
5	Baud rate for port 2	Sets the baud rate for port 2.
6		
7		
8	Not used	Always set this pin to OFF.

## RS-232C Interface

The ASCII Unit is connected to peripheral devices through two RS-232C interfaces.

Electrical characteristics: Conform to EIA RS-232C

D-sub 9-pin connectors are used for both ports.

Assemble the cable connectors supplied with the ASCII Unit. To connect the cables correctly, refer to the following signal table.

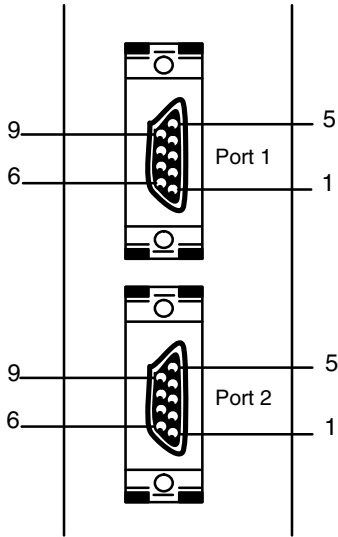

Plug: XM2A-0901 (OMRON) or equivalent.  
 Applicable Connector Hood: XM2S-0901 (OMRON) or equivalent.  
 (Two plugs and two hoods are supplied with the ASCII Unit.)  
 Cable Length: 15 m

Pin No.	Symbol	Name	Direction
1	FG	Frame ground	–
2	SD	Send data	Output
3	RD	Receive data	Input
4	RTS	Request to send	Output
5	CTS	Clear to send	Input
6	–	Not used	–
7	DSR	Data send ready	Input
8	DTR	Data terminal ready	Output
9	SG	Signal ground	–

# Connections to Peripheral Devices

## RS-232 Printer Connections

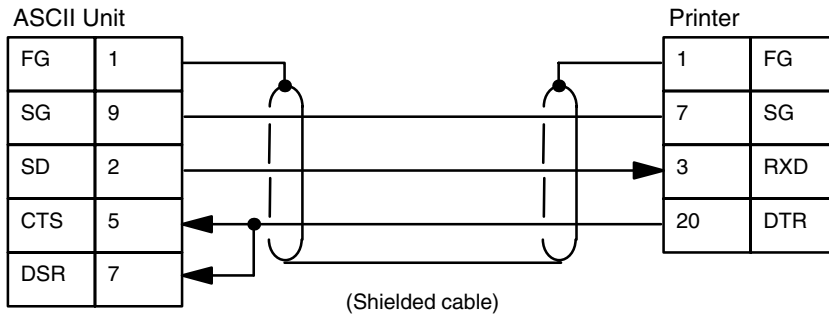

## Connections to a Plasma Display

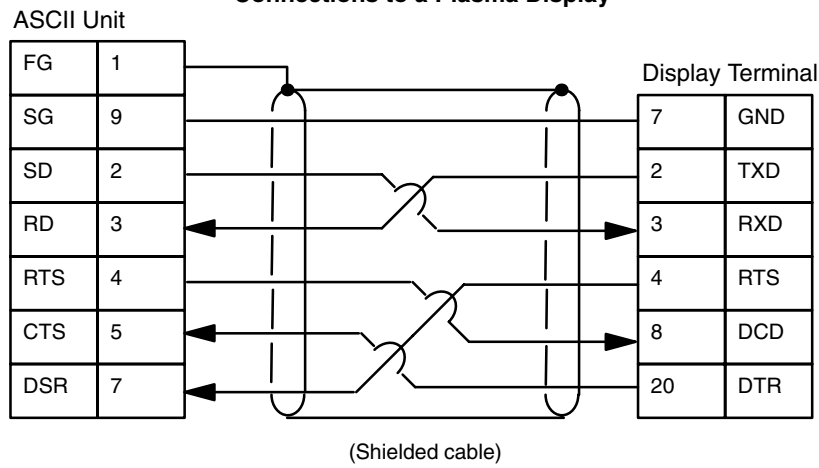

## Connections to a Personal Computer

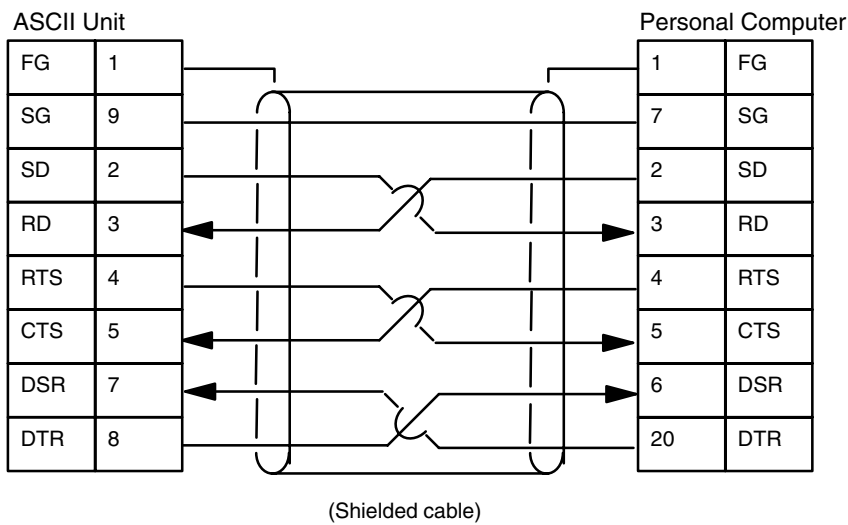

## Interface Signal Timing

The RTS, CTS, DTR, and DSR signals are processed as follows:

### Transmission from the ASCII Unit to a Peripheral Device

The RTS signal is activated by the OPEN command. (The DTR signal goes HIGH or LOW depending on the peripheral device which has been opened by the command.)

When the RTS signal goes HIGH, the status of both the CTS and DSR signals is checked, and then data is transmitted.

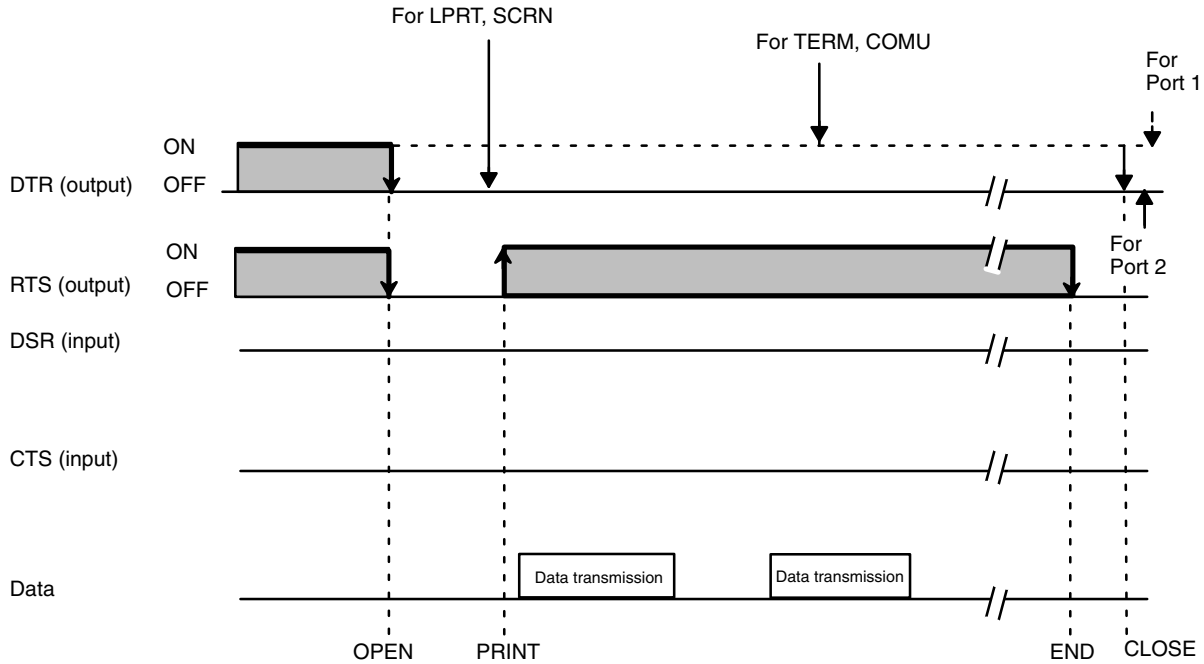

- Note**
1. If the DSR or CTS signal is disabled, these signals will be ignored. However, if the CTS signal to port 2 needs to be disabled, either pull it HIGH or connect it to the RTS signal. If the RTS signal is selected as the valid signal by the OPEN command, the RTS signal will remain HIGH. The RTS signal goes low when the CLOSE command is executed.
  2. If the name of the peripheral device in the OPEN command is TERM or COMU, when the OPEN command is executed, the DTR signal will go HIGH and the RTS signal will go LOW. The RTS signal will go HIGH when the PRINT command is executed. If both the CTS and DSR signals are HIGH, data will then be transferred.
  3. If the name of the peripheral device in the OPEN command is LPRT or SCRN, when the OPEN command is executed, both the DTR and RTS signals will go LOW. The RTS signal will go HIGH when the PRINT command is executed. If both the CTS and DSR signals are HIGH, data will then be transferred.

### Transmission from a Peripheral Device to the ASCII Unit

The DTR signal goes HIGH and the RTS signal goes LOW when the OPEN command is executed. (If the DTR signal has already gone HIGH and the RTS signal has gone LOW, the state of these signals is maintained.)

The RTS signal goes HIGH when the INPUT command is executed and incoming data is received. (This operation is independent of the DSR and CTS signals.)

If the RTS signal is already HIGH when the OPEN command is executed, it will remain HIGH. The RTS signal goes LOW when the CLOSE command is executed.

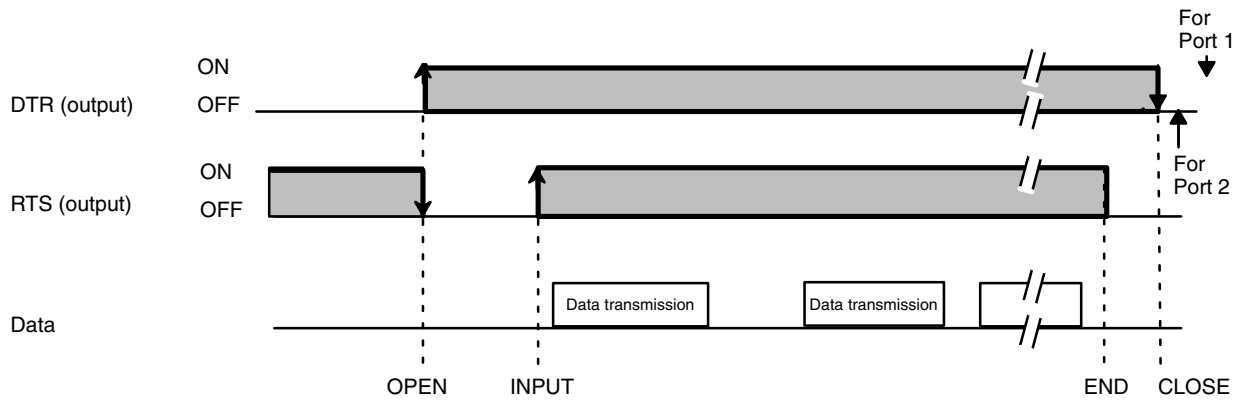

## Device Control Codes

Peripheral Device	Output	
Terminal Display	At execution	The transmission buffer (screen) is cleared when code &H0C is output. The cursor is set to the leftmost position of the screen when code &H0A (LF), &H0D (CR), &H0B (HOME), or &H0C (CLR) is output. The cursor is moved on the screen when code &H08 (BS), &H1C (->), or &H1D (<-) is output. Codes &H16 (cursor ON) and &H17 (cursor OFF) are ignored and are not output.
	CLOSE	Nothing is executed
LPRT	At execution	The cursor is set to the leftmost position when code &H0A, &H0D, &H0B, or &H0C is output. If an output line exceeds 80 characters, code &H0A (LF) is automatically appended to the line data.
	CLOSE	If data remains in the transmission buffer, it is output with code &H0A appended
COMU	At execution	Data is output when characters are sent to the buffer.
	CLOSE	If data remains in the transmission buffer, it is output.

## Dimensions

### Dimensions with ASCII Unit Mounted on PC

The depth of the ASCII Unit is 100.5 mm as shown in the following figure. However, when the Unit is mounted on the PC and when a cable is connected to the Unit, the depth may increase up to 200 mm. Consider this when mounting the ASCII Unit in a control box along with the PC.



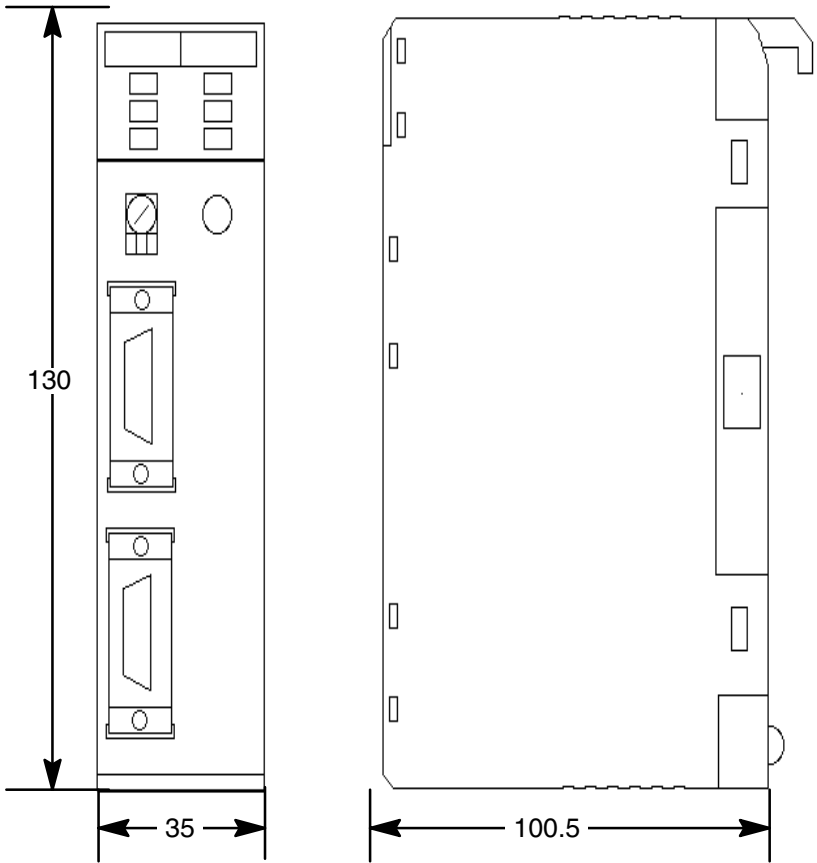



# Appendix C

## PC Statements and Refresh Timing

### Instructions and Refresh Timing

Data transfer between the ASCII Unit and the PC is executed during PC I/O refresh.

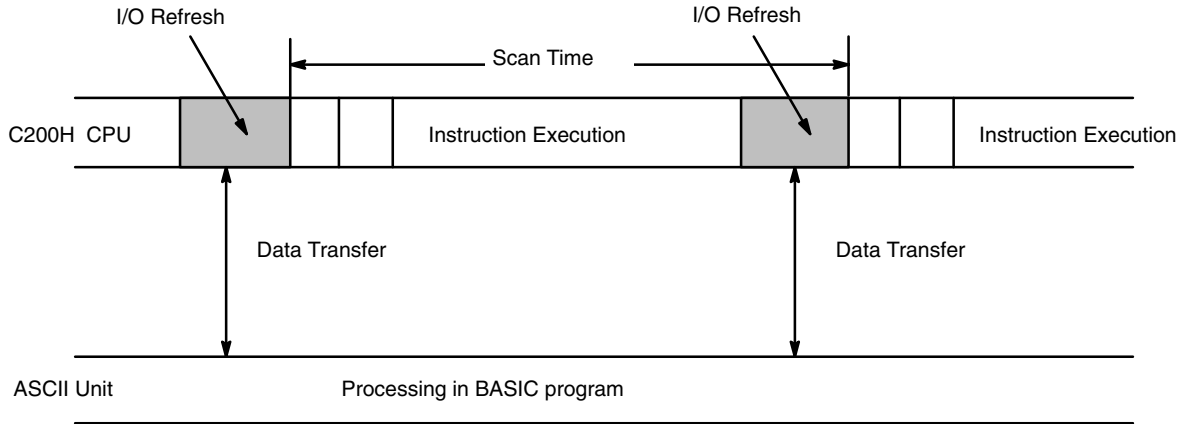

### BASIC Statements and PC Scan Time

#### PC GET

The ASCII Unit takes in data obtained in the last PC I/O refresh before execution of PC GET.

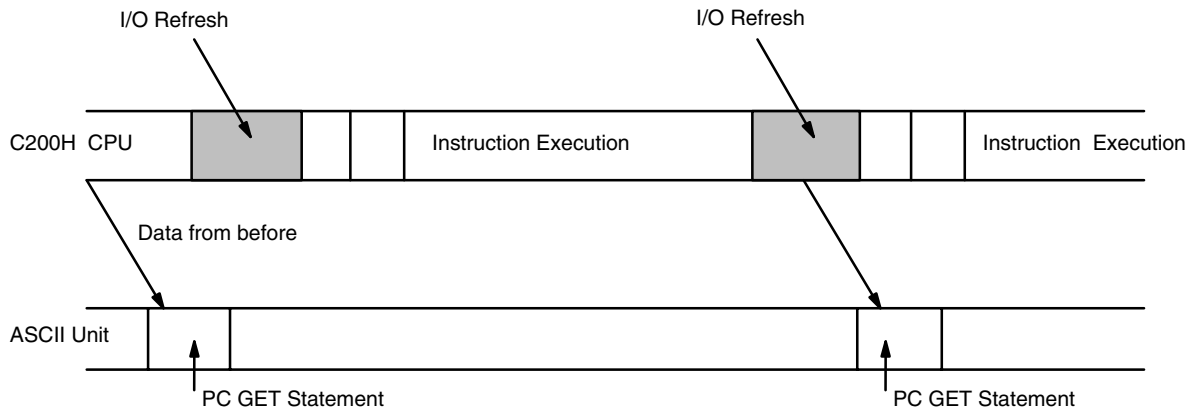

### PC PUT

The ASCII Unit transfers data during the first PC I/O refresh after execution of PC PUT.

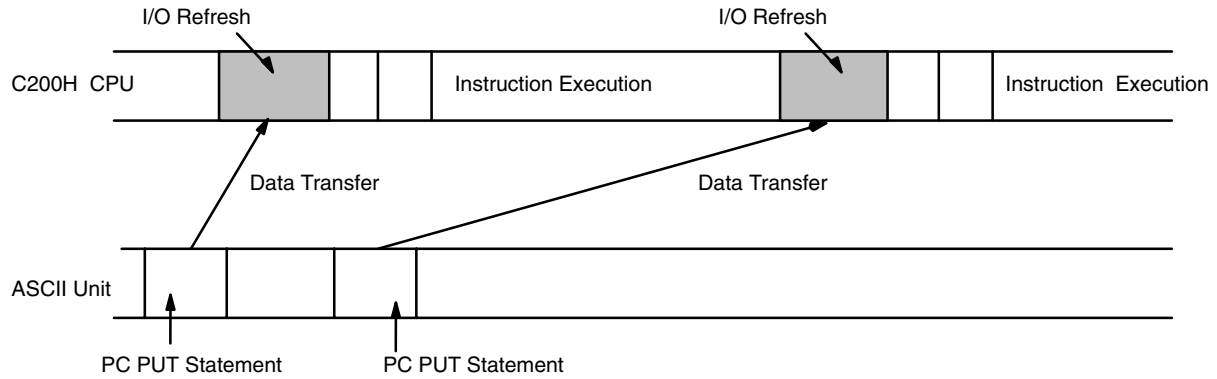

### PC READ

In four-word mode, when the PC's WRITE flag is set, the base address is transferred. By the next I/O refresh the data is read.

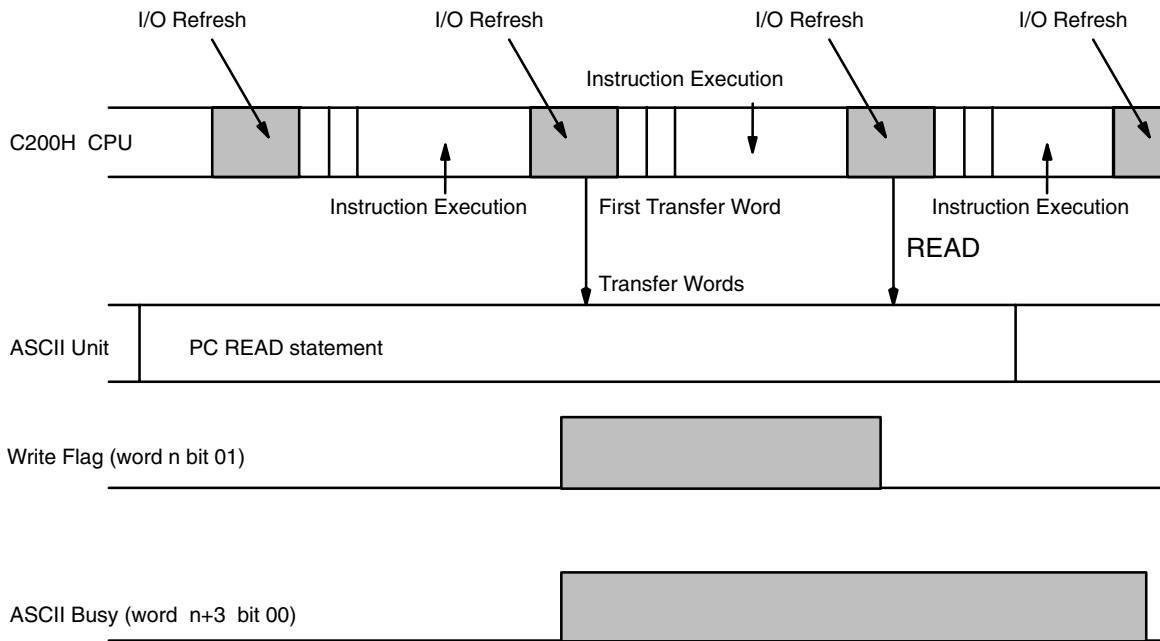

### PC READ @...

Data is read from the first I/O refresh after execution of PC READ @..., irrespective of the status of the Write flag.

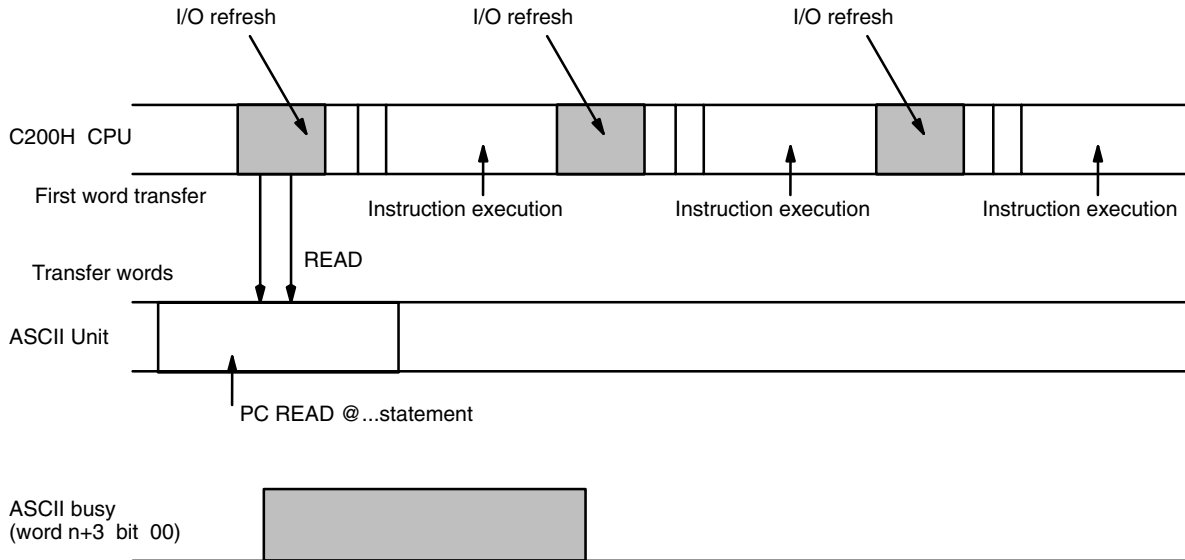

### PC WRITE

In four-word mode, when the PC's READ flag is set during I/O refresh, the PC WRITE statement obtains the base word address and the number of words to be transferred. With the next I/O refresh, data is transferred.

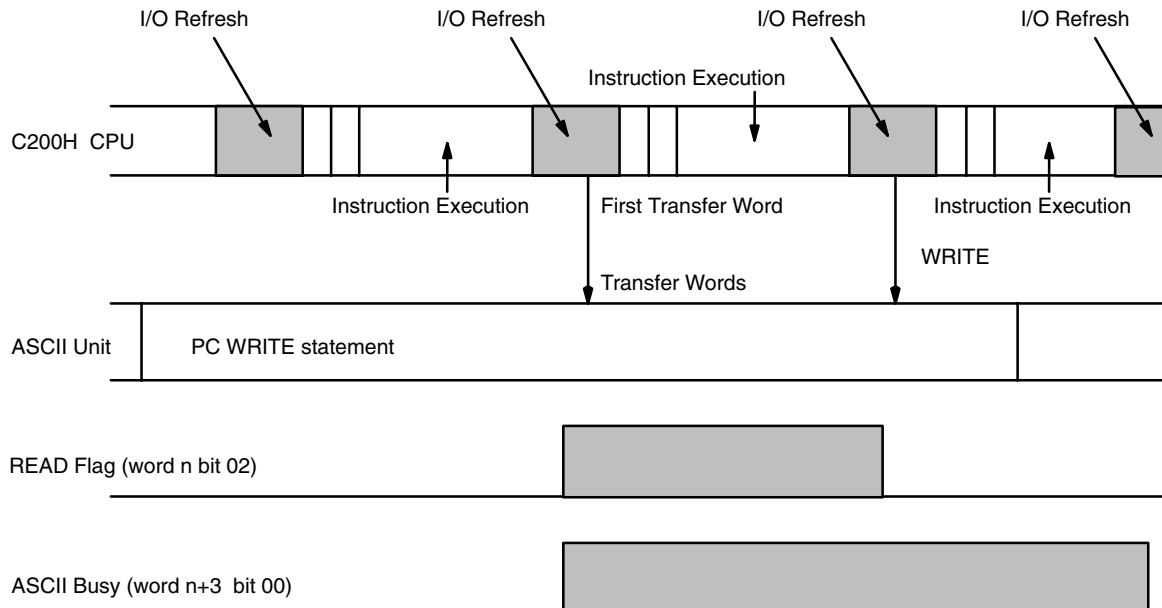

### PC WRITE @...

Data is transferred to the PC during the first I/O refresh after execution of PC WRITE @..., irrespective of the status of the PC READ flag.

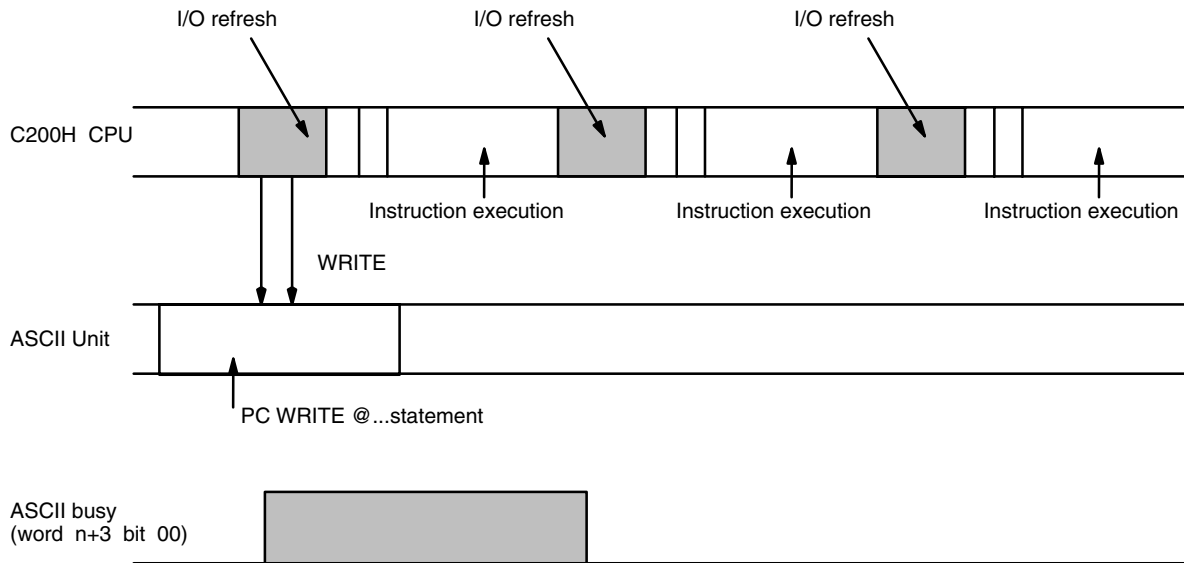

### ON PC GOSUB

After the ON PC GOSUB statement is executed, the PC's interrupt number is written in. When the Write flag is set, the GOSUB statement is executed. Only when the WRITE flag is set will the ON PC GOSUB statement be executed.

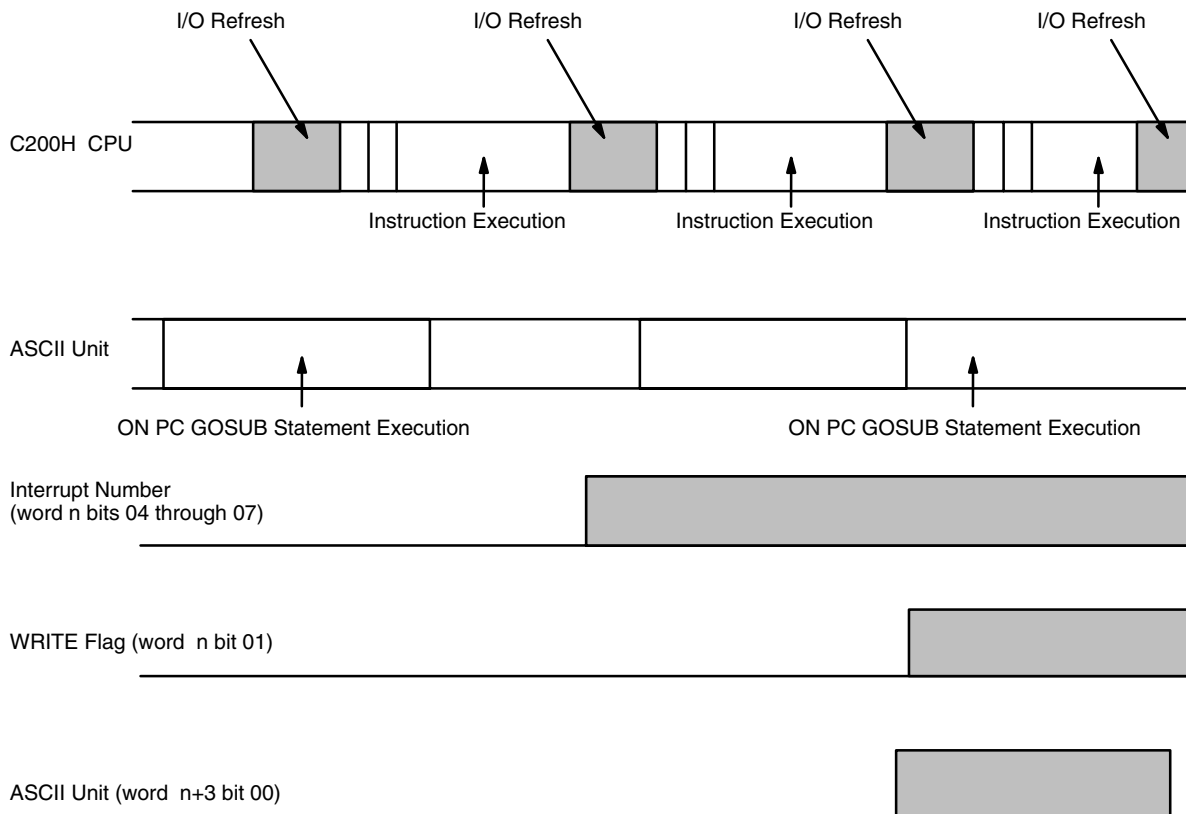

# PC ON

After the ON PC GOSUB statement is executed, the PC's interrupt number is written in. When the Write flag is set, the GOSUB statement is executed. Only when the WRITE flag is set will the ON PC GOSUB statement be executed.

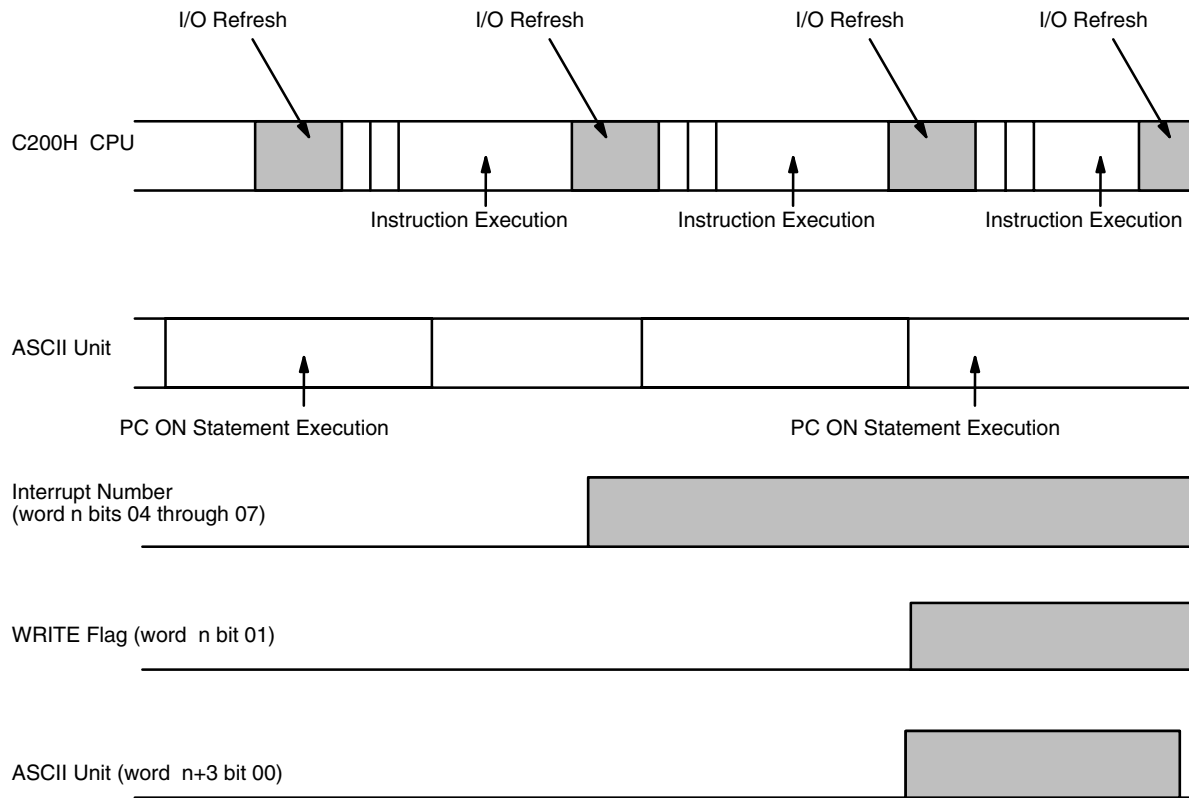

# PC STOP

After the ON PC GOSUB statement is executed, the PC's interrupt number is written in. When the Write flag is set, the ASCII Unit busy flag is set for one scan time, but the GOSUB statement is not executed. Only after the PC ON statement is executed will the ON PC GOSUB statement be executed.

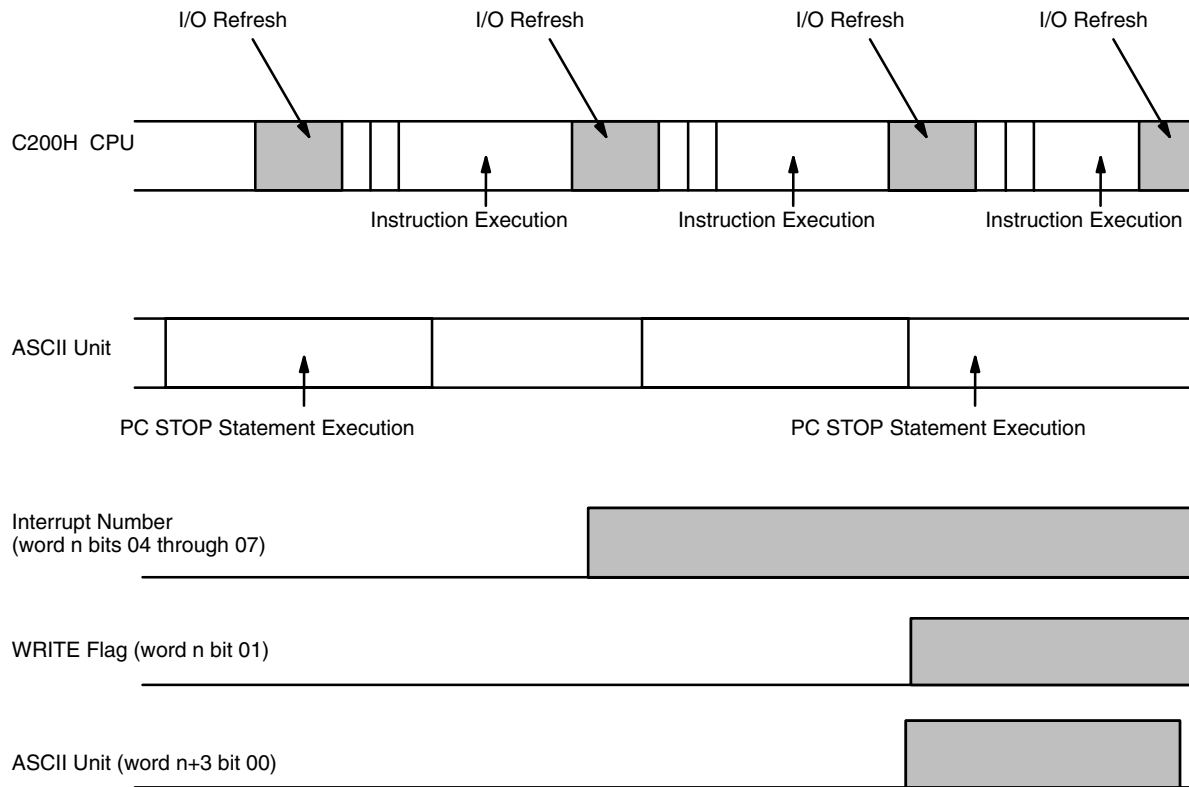



### PC OFF

After the ON PC GOSUB statement is executed, the PC's interrupt number is written in. If the PC OFF statement is subsequently executed, then even if the Write flag is set, the GOSUB statement will not be executed and the ASCII busy flag will not be set.

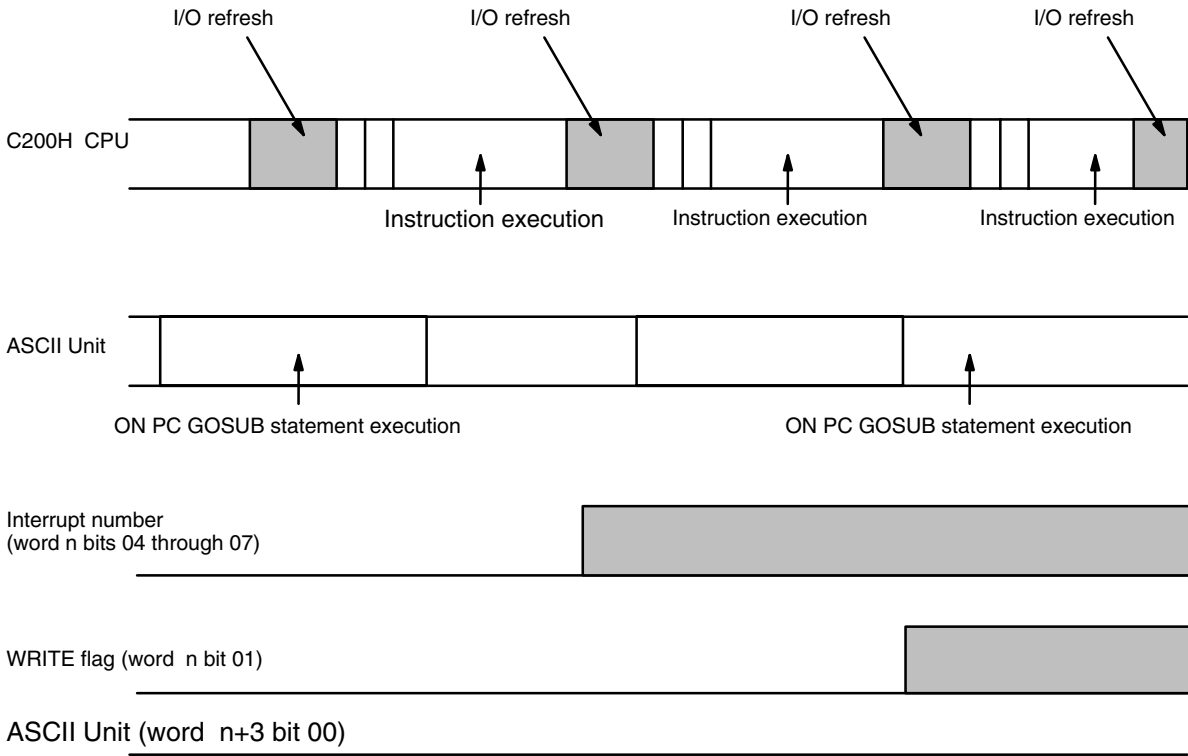



# Appendix D

## Formatting and Data Conversion

### Memory Area Designators for PC READ/PC WRITE Statements

Memory Area Designator	Address Range	
@R	IR Area	0000 to 0255 PC READ 0000 to 0252 PC WRITE
@H	HR Area	0000 to 0099
@A	AR Area	0000 to 0027
@L	LR Area	0000 to 0063
@G	TC Area	0000 to 0511
@D	DM Area	0000 to 1999

### Formatting and Data Conversion

Format	Meaning	Name
m l n	nth byte of m decimal words	I format
m H n	nth byte of m hexadecimal words	H format
m O n	nth byte of m octal words	O format
m B n	nth bit of of m binary words	B format
m A n	nth byte of m ASCII words	A format
Sm X n	nth bit/byte X (where X could be I, H, O or B) of m words	S format

#### Remarks:

When m is omitted, the default value is one.

When using the A format, one format designator corresponds to only one variable in the variable list: e.g., the first format designator corresponds to the first variable in the list, the second format designator corresponds to the second variable in the list, etc.

In all formats except A and S, one format designator can apply to many variables. For example:

“5H2”; A, B, C, D, E

This is the same as “1H2, 1H2, 1H2, 1H2, 1H2”; A, B, C, D, E.

All format designators must be in uppercase characters.

Under normal conditions, the maximum number of words that can be transferred at one time is 255. When using the A or B formats, however, the maximum number of words that can be transferred is between 50 and 60.

### I Format (mln)

This format is used for decimal numbers (0 to 9):

- m** : number of words
- l** : decimal format designator
- n** : the nth digit of the word

Digit n	Bit			
	15 14 13 12	11 10 9 8	7 6 5 4	3 2 1 0
1	–	–	–	$\times 10^0$
2	–	–	$\times 10^1$	$\times 10^0$
3	–	$\times 10^2$	$\times 10^1$	$\times 10^0$
4	$\times 10^3$	$\times 10^2$	$\times 10^1$	$\times 10^0$

Example: 2I3 ... Indicates 2 decimal words of 3 digits each.

## H Format (mHn)

This format is used for hexadecimal numbers (0 to F):

- m** : number of words
- H** : hexadecimal format designator
- n** : the nth digit of the word

Digit n	Bit			
	15 14 13 12	11 10 9 8	7 6 5 4	3 2 1 0
1	–	–	–	$\times 16^0$
2	–	–	$\times 16^1$	$\times 16^0$
3	–	$\times 16^2$	$\times 16^1$	$\times 16^0$
4	$\times 16^3$	$\times 16^2$	$\times 16^1$	$\times 16^0$

Example: 3H4 ... Three hexadecimal words of 4 digits each.

## O Format (mOn)

This format is used for octal numbers (0 to 7):

- m** : number of words
- O** : octal format designator
- n** : the nth byte of the word

Digit n	Bit			
	15 14 13 12	11 10 9 8	7 6 5 4	3 2 1 0
1	–	–	–	$\times 8^0$
2	–	–	$\times 8^1$	$\times 8^0$
3	–	$\times 8^2$	$\times 8^1$	$\times 8^0$
4	$\times 8^3$	$\times 8^2$	$\times 8^1$	$\times 8^0$

Example: 4O2 ... Indicates four octal words of two digits each.

## B Format (mBn)

This format is used for binary numbers (0 to 1):

- m** : number of words
- B** : binary format designator
- n** : the nth bit of the word

Digit n	Bit															
	15	14	13	12	11	10	09	08	07	06	05	04	03	02	01	00
0	-	-	-	-	-	-	-	-	-	-	-	-	-	-	-	x 2 <sup>0</sup>
1	-	-	-	-	-	-	-	-	-	-	-	-	-	-	x 2 <sup>1</sup>	-
2	-	-	-	-	-	-	-	-	-	-	-	-	-	x 2 <sup>2</sup>	-	-
3	-	-	-	-	-	-	-	-	-	-	-	-	x 2 <sup>3</sup>	-	-	-
4	-	-	-	-	-	-	-	-	-	-	-	x 2 <sup>4</sup>	-	-	-	-
5	-	-	-	-	-	-	-	-	-	-	x 2 <sup>5</sup>	-	-	-	-	-
6	-	-	-	-	-	-	-	-	-	x 2 <sup>6</sup>	-	-	-	-	-	-
7	-	-	-	-	-	-	-	-	x 2 <sup>7</sup>	-	-	-	-	-	-	-
8	-	-	-	-	-	-	-	x 2 <sup>8</sup>	-	-	-	-	-	-	-	-
9	-	-	-	-	-	-	x 2 <sup>9</sup>	-	-	-	-	-	-	-	-	-
10	-	-	-	-	-	x 2 <sup>10</sup>	-	-	-	-	-	-	-	-	-	-
11	-	-	-	-	x 2 <sup>11</sup>	-	-	-	-	-	-	-	-	-	-	-
12	-	-	-	x 2 <sup>12</sup>	-	-	-	-	-	-	-	-	-	-	-	-
13	-	-	x 2 <sup>13</sup>	-	-	-	-	-	-	-	-	-	-	-	-	-
14	-	x 2 <sup>14</sup>	-	-	-	-	-	-	-	-	-	-	-	-	-	-
15	x 2 <sup>15</sup>	-	-	-	-	-	-	-	-	-	-	-	-	-	-	-

Example: 5B14... Indicates five binary words of 14 bits each.

## A Format (mAn)

This format is used for ASCII characters:

- m** : number of words
- A** : ASCII format designator
- n** : the nth byte of the word

Digit n	Bit															
	15	14	13	12	11	10	9	8	7	6	5	4	3	2	1	0
1	-								ASCII code							
2	ASCII code								-							
3	ASCII code								ASCII code							

Example: 6A2... Indicates six ASCII words of two characters each.

A maximum of 255 words can be transferred at one time when the A format is used because many PC words can be represented by one BASIC variable.

Example: PC READ "50A3, 100A2, 30A1, 75A3"; A\$, B\$, C\$, D\$

A\$: Fifty PC words (50 words x 2 characters = 100 characters) indicated by 50A3 are assigned to this variable.

B\$: One hundred PC words (100 words x 1 character = 100 characters) indicated by 100A2 are assigned to this variable.

C\$: Thirty PC words (30 words x 1 character = 30 characters) indicated by 30A1 are assigned to this variable.

D\$: Seventy-five PC words (75 words x 2 characters = 150 characters) indicated by 75A3 are assigned to this variable.

## S Format (SmIn, SmHn, SmOn, SmBn)

This format is used for array variables.

- S** : format designator
- m** : number of words
- n** : the digits of the specified format type

<b>Format</b>	<b>Meaning</b>
SmIn	Indicates an array in decimal format.
SmHn	Indicates an array in hexadecimal format.
SmOn	Indicates an array in octal format.
SmBn	Indicates an array in binary format.

Remarks:

Each S Format designator corresponds to one variable from the variable list: the first designator corresponds to the first variable in the list, etc.

The array variables must be one dimensional. Each array variable in the list must indicate (with a subscript) a specific element within the array. The number of words to be written to or read from the array will be incremented from the specified element. For example: if the array variable T(4) is specified in a READ statement and the corresponding format is S100I4, then 100 words will be read from the array, starting at T(4) and ending at T(104).

Example:        PC READ "S100I4, S75H2, S80O3"; A(1), B(11), C(51)

A(1) to A(100): A hundred words of 4-digit decimal data indicated by S100I4 are read to these variables.

B(11) to B(85): Seventy-five words of 2-digit hexadecimal data indicated by S75H2 are read to these variables.

C(51) to C(130): Eighty words of 3-digit octal data indicated by S80O3 are read to these variables.

# Examples of PC READ Format Conversion

## I Format

Contents of PC word

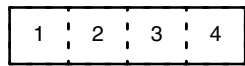

Integer variable

Character variable

```

PC READ "I 1"; J → J = 4
PC READ "I 2"; J → J = 3 4
PC READ "I 3"; J → J = 2 3 4
PC READ "I 4"; J → J = 1 2 3 4
    
```

```

PC READ "I 1"; A$ → A$ = " 4 "
PC READ "I 2"; A$ → A$ = " 3 4 "
PC READ "I 3"; A$ → A$ = " 2 3 4 "
PC READ "I 4"; A$ → A$ = " 1 2 3 4 "
    
```

## H Format

Contents of PC word

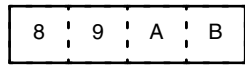

Integer variable

Character variable

```

PC READ "H 1"; J → J = &H B = 11
PC READ "H 2"; J → J = &H A B = 171
PC READ "H 3"; J → J = &H 9 A B = 2475
PC READ "H 4"; J → J = &H 8 9 A B = -30293
    
```

```

PC READ "H 1"; A$ → A$ = " B "
PC READ "H 2"; A$ → A$ = " A B "
PC READ "H 3"; A$ → A$ = " 9 A B "
PC READ "H 4"; A$ → A$ = " 8 9 A B "
    
```

## O Format

Contents of PC word

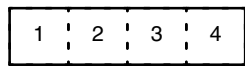

Integer variable

Character variable

```

PC READ "O 1"; J → J = & 4 = 4
PC READ "O 2"; J → J = & 3 4 = 28
PC READ "O 3"; J → J = & 2 3 4 = 156
PC READ "O 4"; J → J = & 1 2 3 4 = 668
    
```

```

PC READ "O 1"; A$ → A$ = " 4 "
PC READ "O 2"; A$ → A$ = " 3 4 "
PC READ "O 3"; A$ → A$ = " 2 3 4 "
PC READ "O 4"; A$ → A$ = " 1 2 3 4 "
    
```

## B Format

Contents of PC word

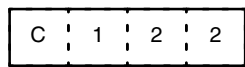

Integer variable

Character variable

```

PC READ "B 1"; J → J = 2
PC READ "B 2"; J → J = 0
PC READ "B 5"; J → J = 32
PC READ "B 14"; J → J = 16384
PC READ "B 15"; J → J = -32768
    
```

```

PC READ "B 1"; A$ → A$ = " 2 "
PC READ "B 2"; A$ → A$ = " 0 "
PC READ "B 5"; A$ → A$ = " 32 "
PC READ "B 14"; A$ → A$ = " 16384 "
PC READ "B 15"; A$ → A$ = " -32768 "
    
```

## A Format

Contents of PC word

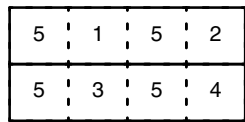

Character variable

Note: The integer variable causes an error because it does not match the binary data format.

```

PC READ "2 A 1"; A$ → A$ = " RT "
PC READ "2 A 2"; A$ → A$ = " QS "
PC READ "2 A 3"; A$ → A$ = " QRST "
    
```

```

Q: &H 51
R: &H 52
S: &H 53
T: &H 54
    
```

**S Format**

Contents of PC word

0	1	2	3
4	5	6	7
8	9	0	1
2	3	4	5

Integer variable  
(in format I)

PC READ "S4I4 "; A(1)

A(1) = 9876  
A(2) = 5432  
A(3) = 1098  
A(4) = 7654

**Examples of PC Write Format Conversion**

**I Format**

Contents of PC word

0	0	0	4
---	---	---	---

← PC WRITE "I1 "; J

0	0	3	4
---	---	---	---

← PC WRITE "I2 "; J

0	2	3	4
---	---	---	---

← PC WRITE "I3 "; J

1	2	3	4
---	---	---	---

← PC WRITE "I4 "; J

} Integer variable ← J = 1234

0	0	0	1
---	---	---	---

← PC WRITE "I1 "; A\$

0	0	1	2
---	---	---	---

← PC WRITE "I2 "; A\$

0	1	2	3
---	---	---	---

← PC WRITE "I3 "; A\$

1	2	3	4
---	---	---	---

← PC WRITE "I4 "; A\$

} Character variable ← A\$ = "1234"



**H Format**

Contents of PC word

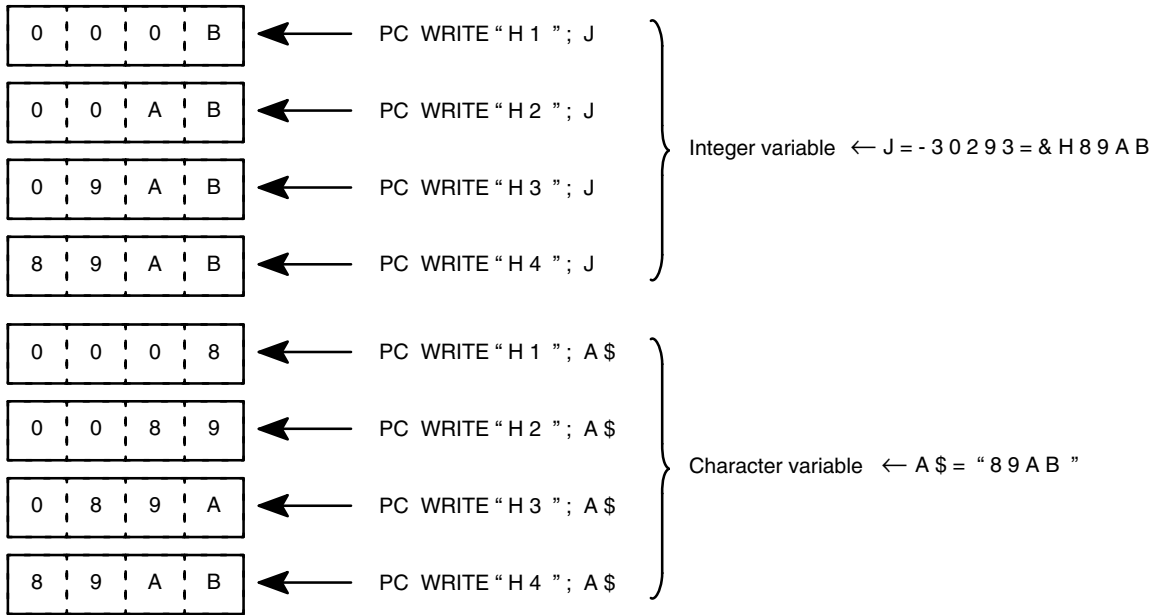

**O Format**

Contents of PC word

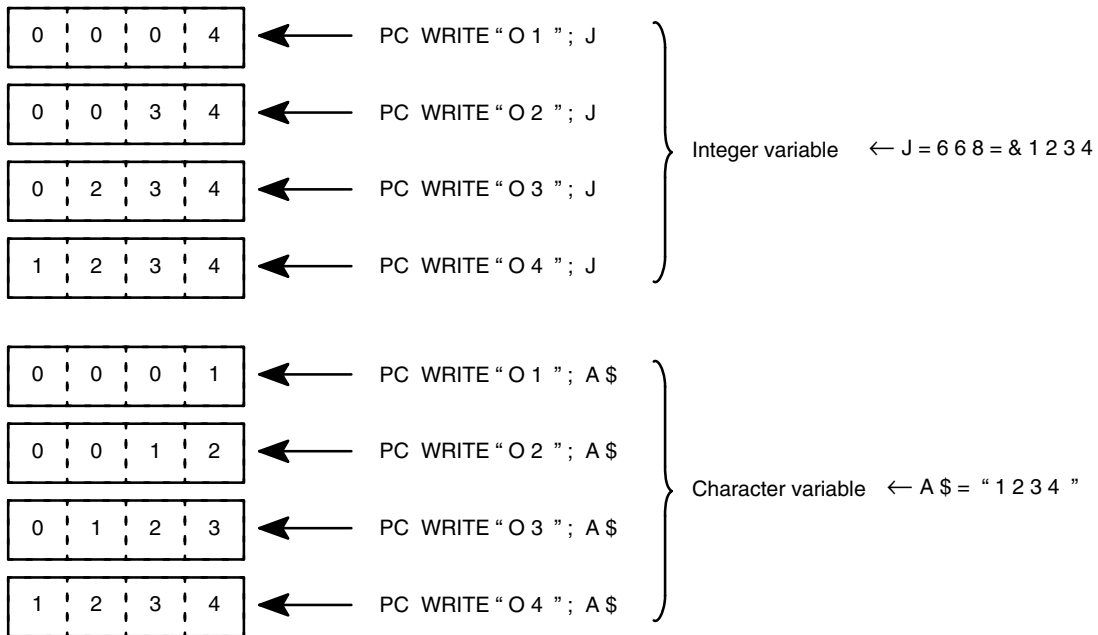

**B Format**

Contents of PC word

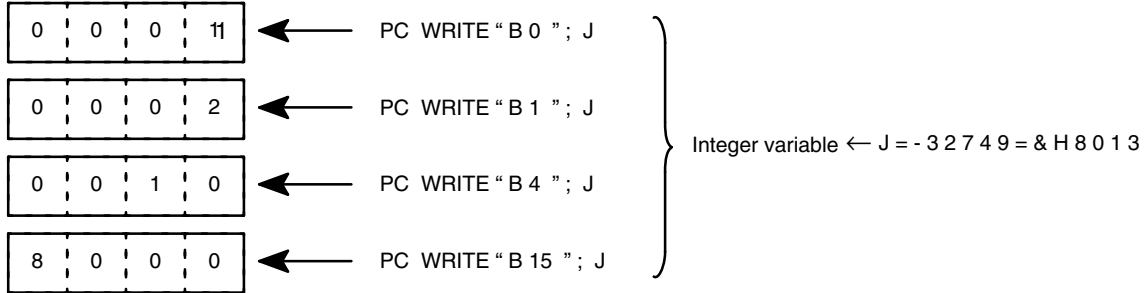

**Note** Integer variables in B format will cause an error.

**A Format**

Contents of PC word

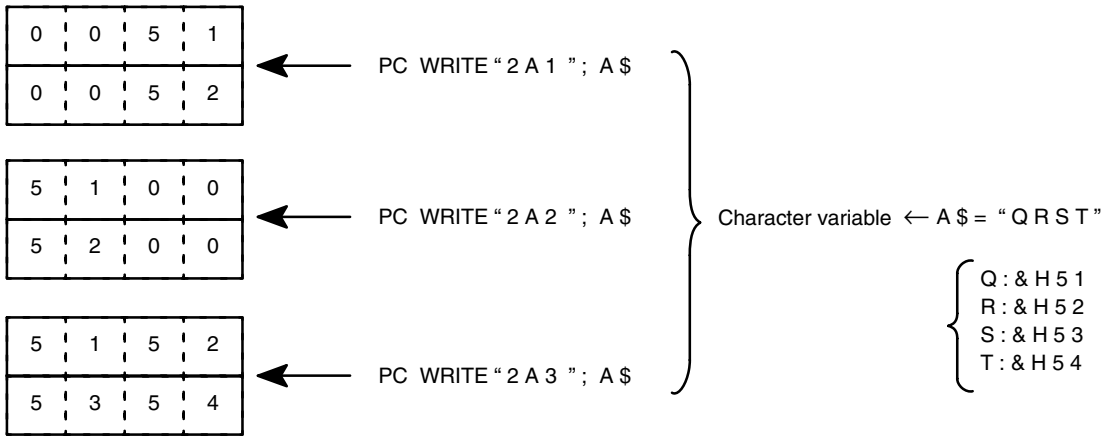

**S Format**

Contents of PC word

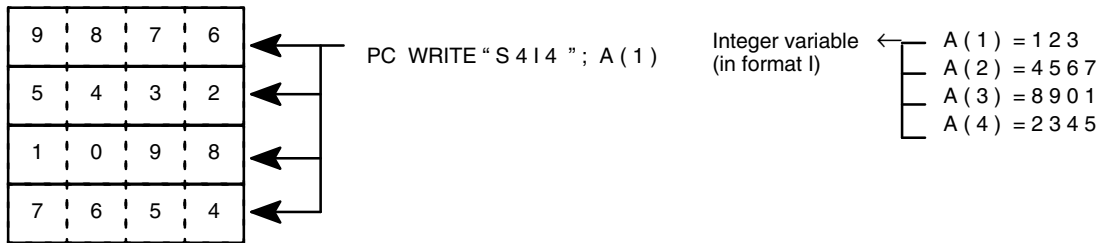

## Execution Times

Command	Execution time (ms)
PC READ "I4" ; A	8.5
PC READ "5I4" ; A, B, C, D, E	21.1
PC READ "10I4" ; A, B, C, D, E, G, H, I, J	43.8
PC READ "100A3, 100A3, 55A3" ; A\$, B\$, C\$	67.7
PC WRITE "I4" ; A	8.7
PC WRITE "5I4" ; A, B, C, D, E	22.1
PC WRITE "10I4" ; A, B, C, D, E, G, H, I, J	39.3
PC WRITE "100A3, 100A3, 55A3" ; A\$, B\$, C\$	57.9
PC READ "@D, 0, 1, I4" ; A	5.0
PC READ "@D, 0, 5, 5I4" ; A, B, C, D, E	18.6
PC READ "@D, 0, 10, 10I4" ; A, B, C, D, E, G, H, I, J	40.3
PC READ "@D, 0, 255, 100A3, 100A3, 55A3" ; A\$, B\$, C\$	65.3
PC WRITE "@D, 0, 1, I4" ; A	4.4
PC WRITE "@D, 0, 5, 5I4" ; A, B, C, D, E	19.0
PC WRITE "@D, 0, 10, 10I4" ; A, B, C, D, E, G, H, I, J	37.5
PC WRITE "@D, 0, 255, 100A3, 100A3, 55A3" ; A\$, B\$, C\$	54.4

### Remarks:

The execution times listed in this table do not include the time required for handshaking. The actual execution time varies depending on the scan time of the PC as follows:

Twenty or fewer words are to be transferred:

- without memory area designator: 2 PC scan times max.
- with memory area designator: 1 PC scan time max.

More than 20 words are to be transferred:

- without memory area designator:  $\text{INT}(\text{No. of words} - 1) / 20 + 2$  scan times max.
- with memory area designator:  $\text{INT}(\text{No. of words} - 1) / 20 + 1$  scan time max.



# Appendix E

## ASCII Unit Memory Map

### Memory Structure

The memory structure is shown below. The addresses go from &H0000 to &HFFFF (0 to 65535) and are divided into byte units. The 24 Kbytes (24,576 bytes) from &H2000 to &H7FFF make up the program area. The contents of this program area can be read with the PEEK function (refer to page 62 for details). &H0000 to &H1FFF and &H8000 to &HFFFF (shaded in the diagrams below) are set by the system and so cannot be read.

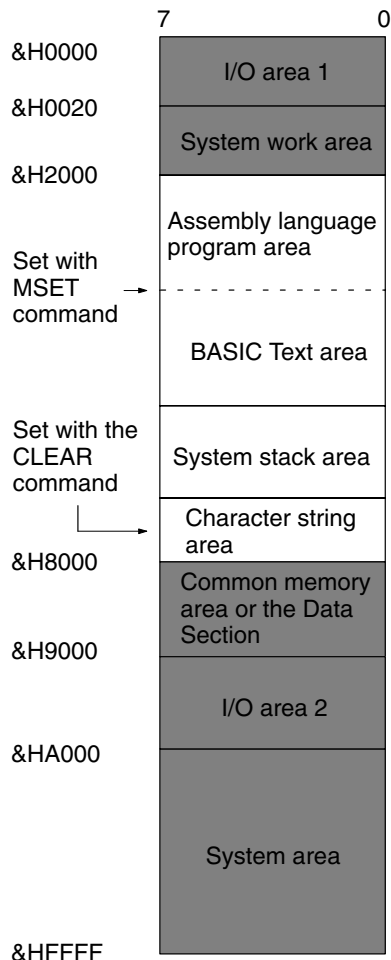

- : Program area
- : System settings area

Memory Area	Remarks
I/O area 1 (&H0000 to &H001F)	This area is for internal ports of the microprocessor 63B03.
System work area (&H0020 to &H1FFF)	This area is used by the system.
Assembly language program area	Stores assembly language program. The size of this area can be changed with MSET command.
BASIC Text area	
System stack area	Stack area used by the system.
Character string area	Stores character strings. The size of this area is normally 200 bytes and is set with the CLEAR command.
Common memory area or the Data Section (&H8000 to &H8FFF)	RAM area for interfacing between ASCII Unit and PC. When this area is accessed, an I/O UNIT ERROR may occur. Do not access this area.
I/O area 2 (&H9000 to &H9FFF)	Area to which ports ACIA, PTM, and RTC are assigned.
System area (&HA000 to &HFFFF)	This is the ROM area.

## Port Address Assignments

Address	R/W	Contents	System Default Value
\$0010 Port 1	R/W	Transfer rate/mode control register	\$34
\$0011 "	R/W	TX/RX control status register	\$00
\$0012 "	R	Receive data register	None
\$0013 "	W	Transmit data register	None
\$9400 Port 2	R	Status register	None
\$9400 "	W	Control register	\$11
\$9401 "	R	Receive data register	None
\$9401 "	W	Transmit data register	None

# Communication Flags

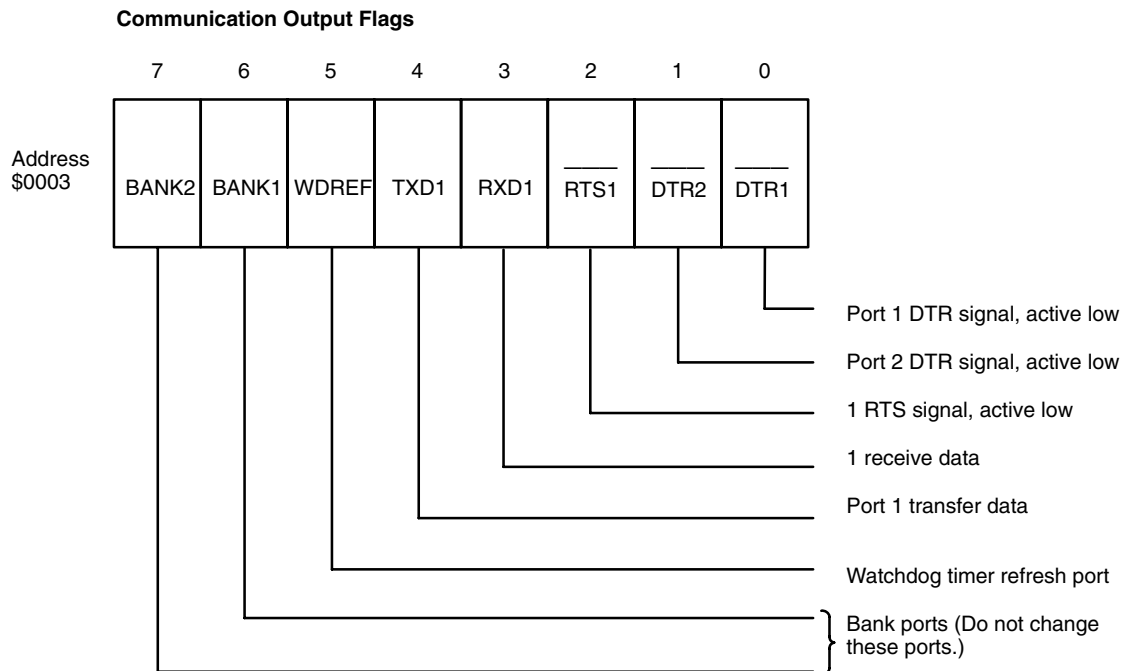
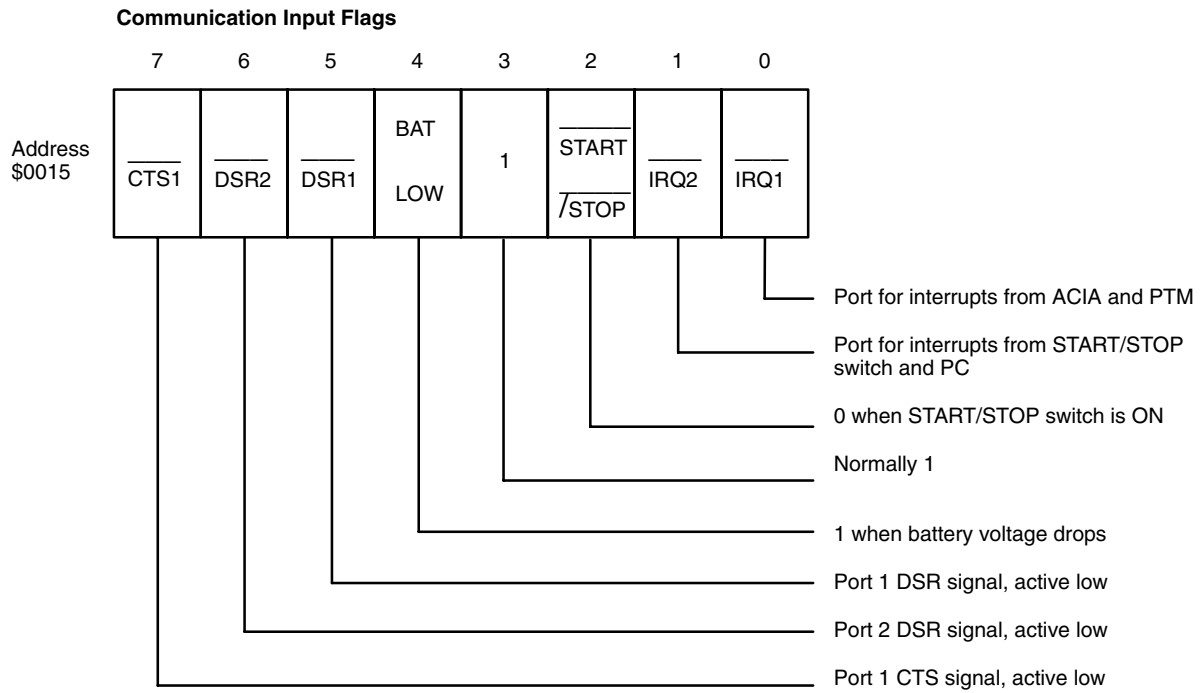

**Devices****PTM HD63B40**

Address	R/W	Contents	System Default Value	Remarks
\$9800	R	0	None	
	W	Control registers #1 and #3	\$82	Writes to #3
\$9801	R	Status register	None	
	W	Control register #2	\$00	
\$9802	R	Higher byte of timer #1 counter	None	
	W	Higher byte (MSB) of buffer register	None	
\$9803	R	Lower byte (LSB) of buffer register	None	
	W	Lower byte of timer 1 latch	None	
\$9804	R	Higher byte of timer #2 counter	None	
	W	Higher byte (MSB) of buffer register	None	
\$9805	R	Lower byte (LSB) of buffer register	None	
	W	Lower byte of timer #2 latch	None	
\$9806	R	Higher byte of timer #3 counter	None	
	W	Higher byte (MSB) of buffer register	None	Changes depend on transfer rate
\$9807	R	Lower byte (LSB) of buffer register	None	
	W	Lower byte of timer #3 latch	None	

**RTC-62461 Real-Time Clock**

Address	R/W	Contents	System Default Value
\$9000	R/W	1-second digit: 0-9	None
\$9001	R/W	10-second digit: 0-5	None
\$9002	R/W	1-minute digit: 0-9	None
\$9003	R/W	10-minute digit: 0-5	None
\$9004	R/W	1-hour digit: 0-9	None
\$9005	R/W	10-hour digit: 0-2	None
\$9006	R/W	1-day digit: 0-9	None
\$9007	R/W	10-day digit: 0-3	None
\$9008	R/W	1-month digit: 0-9	None
\$9009	R/W	10-month digit: 0-1	None
\$900A	R/W	1-year digit: 0-9	None
\$900B	R/W	10-year digit: 0-9	None
\$900C	R/W	Week digit: 0-6	None
\$900D	R/W	Control register D	0 is set in D0.
\$900E	R/W	Control register E	None
\$900F	R/W	Control register F	0 is set in D0, 1, and 3.



## Transmission and Reception Work Area

Address	Contents	
\$0145	Port 1	Port storage pointer (reception)
\$0146		Data extraction pointer (reception)
\$0147		Data storage pointer (transfer)
\$0148		Reception buffer, 256 bytes
\$024B	Port 2	Data storage pointer (reception)
\$024C		Data extraction pointer (reception)
\$024D		Data storage pointer (transfer)
\$024E		Reception buffer, 256 bytes
\$1440	Port 1	Transfer buffer, 256 bytes
\$1540	Port 2	Transfer buffer, 256 bytes



# Appendix F

## Troubleshooting

### Error Message Format

When an error occurs during BASIC program execution, the error messages shown in the following tables are output to the screen of the terminal. If a device other than a terminal is connected to port 1, the program stops, and the messages are reserved until the terminal is attached and CTRL+X is keyed in.

#### Example of a displayed message:

SYNTAX ERROR IN xxxx

xxxx is displayed when a command is executed with a number specified.

### Errors

Error Message	Error code	Explanation
BAD DATA IN PORT ERROR	58	Format of data read from port is wrong.
BAD I/O MODE ERROR	51	Wrong port or peripheral device has been specified.
BAD PORT DESCRIPTOR ERROR	55	Descriptor is incorrect.
BAD PORT NUMBER ERROR	50	Port number is incorrect.
BAD SUBSCRIPT ERROR	9	Subscript outside predetermined range is used. Assign subscript of maximum value with the DIM command.
CAN'T CONTINUE ERROR	17	Program execution cannot be resumed. Execute program with RUN command.
DEVICE I/O ERROR	53	Error has occurred during communication with a peripheral device.
DEVICE UNAVAILABLE ERROR	60	Wrong device name has been specified.
DIVISION BY ZERO ERROR	11	Attempt is made to divide data by 0.
DIRECT STATEMENT IN PORT ERROR	56	Unnumbered line has been read while program is being loaded.
DUPLICATE DEFINITION ERROR	10	Array, or user function, is defined in duplicate.
FORMAT ERROR	67	Incorrect format or memory area designator, number of words to be transferred or base address has not been specified.
FOR WITHOUT NEXT ERROR	23	FOR and NEXT statements are not correctly used in pairs.
ILLEGAL DIRECT ERROR	12	Attempt is made to execute statements that cannot be executed in direct mode. INPUT and LINE INPUT can be executed in BASIC program only.
ILLEGAL FUNCTION CALL ERROR	5	Statement or function is called incorrectly.
INPUT PAST END ERROR	54	All data in port has been read.
MISSING OPERAND ERROR	22	Necessary parameter is missing.
NEXT WITHOUT FOR ERROR	1	NEXT and FOR statements are not used in pairs.
NO RESUME ERROR	19	RESUME statement is missing in error processing routine.
NO SUPPORT ERROR	64	That operation is not supported.
OUT OF DATA ERROR	4	No data exists to be read by READ statement. Check number of variables in READ statements and number of constants in DATA statements.
OUT OF MEMORY ERROR	7	Memory capacity is full. Expand BASIC program area by CLEAR and MSET commands.

Error Message	Error code	Explanation
OUT OF STRING SPACE ERROR	14	Character area is insufficient. Expand area by CLEAR command.
OVERFLOW ERROR	6	Numeric value exceeds predetermined range.
PORT ALREADY OPEN ERROR	52	Port with specified number has already been opened. This error message appears when attempt is made to open port more than once with the OPEN statement. Delete unnecessary OPEN statements.
PORT NOT OPEN ERROR	57	Unopened port or I/O device is specified. Open port with the OPEN statement.
PROM ERROR	65	EEPROM is malfunctioning, or nothing is written in the EEPROM.
PROTECTED PROGRAM ERROR	62	Program is protected. To change program, delete name with PNAME command.
RESUME WITHOUT ERROR	20	RESUME statement is executed when no error exists.
RETURN WITHOUT GOSUB ERROR	3	RETURN statement is encountered before execution of GOSUB statement.
STRING FORMULA TOO COMPLEX ERROR	16	Character expression is too complex.
STRING TOO LONG ERROR	15	Character string is too long.
SYNTAX ERROR	2	Program does not conform to syntax.
TYPE MISMATCH ERROR	13	Variable types do not match.
UNDEFINED LINE NUMBER ERROR	8	Specified line number is wrong.
UNDEFINED USER FUNCTION ERROR	18	User function is not defined. Define execution start address with the DEF USR statement.
VERIFY ERROR	66	Error occurs during EEPROM verification.

## Abnormalities

Item	Cause	Correction
All indicators do not light.	Power to PC is OFF.	Turn ON power to PC.
	ASCII Unit is not mounted on PC securely.	Tighten mounting screws.
	One of Special I/O Units on PC is defective. PC does not start in this case.	Exchange defective Special I/O Unit with new one. Defective unit is identified by \$ when I/O table is read.
	Unit numbers are assigned to Special I/O Unit in duplicate. PC does not start in this case.	Correct unit number assignment. Unit numbers are displayed when I/O table is read.
	Refreshing between PC and ASCII Unit is not performed correctly. Only ASCII Unit stops in this case.	Find and remove cause and restart ASCII Unit by turning ON and then OFF auxiliary memory relay (AR 0100 to 0109) corresponding to ASCII Unit. If ASCII Unit still does not start, replace Unit with new one.
ERR indicator comes on.	Power to peripheral device is OFF.	Turn ON power to device.
	Cable for device is disconnected.	Correctly connect cable, and tighten screws.
	Breakage in cable or faulty contact exists.	Repair or replace cable.
	Transfer rates and communication conditions of ASCII Unit and peripheral device do not match.	Correct transfer rates and communication conditions.
ERR 1 indicator comes on.	Battery connector is disconnected.	Correctly connect battery connector.
	Battery voltage has dropped.	Replace battery.
Initial screen is <<PROGRAM MEMORY ERROR>>, and CTRL+X is ineffective.	BASIC program is damaged.	Press CTRL+I, and BASIC program will be erased. (If program is backed up in EEPROM, program can later be restored by LOAD command.)

## Inspection Items

The following items should be periodically inspected.

Item	particulars	Criteria
Environment	Is ambient temperature appropriate?	0± to 55°C
	Is ambient humidity appropriate?	35% to 85% (without condensation)
	Is dust built up?	Must be free from dust.
Mounting condition	Are cable screws loose?	Must not be loose.
	Is cable broken?	Must be mounted properly.

## Maintenance Parts

The battery life is 5 years at 25°C. The battery life is shortened at higher temperatures. When the battery voltage drops, the ERR 1 LED indicator blinks, and battery error flag (word n+3 bit 06, where n = 100 + 10 x machine number) turns ON. Replace the battery within 1 week after the indicator blinks.

1. Turn OFF power to the ASCII Unit. If power is not supplied to the Unit, apply power to the Unit for at least 1 minute, then turn it OFF.
2. Remove the ASCII Unit from the PC by pushing down the locking lever on the PC with a screwdriver.
3. With a Phillips screwdriver, remove the two screws, from the ASCII Unit.
4. With a standard screwdriver, remove the cover of the ASCII Unit.
5. Pull out the PC board from the housing.
6. Disconnect the battery and connector and replace them with new ones.
7. Reassemble the ASCII Unit in the reverse order of disassembly.

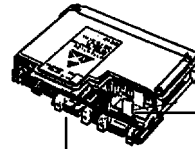
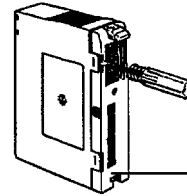
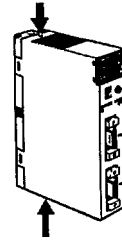

Battery connector

Back of Unit

Battery holder



Battery Set  
C200H-BAT09

## Notes on Handling

Replace the ASCII Unit after turning off the power to the PC.

When returning a defective Unit to OMRON, inform us of the abnormal symptom/s in as much detail as possible.

# Appendix G

## Reference Tables

The following tables list the BASIC commands, statements, and functions alphabetically. A detailed explanation of each command, statement, and function may be found in *Section 4-2 Basic Language*.

The characters in the Command, Statement, and Function columns denote the following:

Gen: General statement	Char: Character String function
Dev: Device Control statement	Spec: Special function
Arith: Arithmetic Operation function	Comm: Command

Item	Description	Command	Statement	Function	Execution Time (ms)	Page
ABS	Returns the absolute value of a number			Arith	5.2	54
ACOS	Returns the arc cosine of a number			Arith	2.8	54
ASC	Returns the value of the first character in a character string			Char	2.4	57
ASIN	Returns the arc sine of a number			Arith	2.8	55
ATN	Returns the arc tangent of a number			Arith	19.9	55
AUTO	Automatically generates line numbers	Comm				26
CDBL	Rounds off a numeric value to make an integer			Arith	5.3	55
CHR\$	Returns the character corresponding to the ASCII code given by the argument			Char	2.5	57
CINT	Converts a numeric value into a double-precision real number			Arith	3.1	55
CLEAR	Initializes numeric and character variables		Gen		1.7	32
CLOSE	Closes a port		Dev		1.3	51
CLS	Clears the screen		Dev		25.4	52
COM ON/OFF/STOP	Enables, disables, or stops an interrupt from a communication port		Gen			32
CONT	Resumes execution of a program that has been stopped	Comm				26
COS	Returns the cosine of a number			Arith	18.6	55
CSNG	Converts a numeric value into a single-precision real number			Arith	2.6	55
DATA	Defines numeric and character variables for subsequent READ statements		Gen			33
DATE\$	Sets or assigns the date			Spec	2	60
DAY	Sets or assigns the day (in numbers)			Spec	1.5	60
DEF FN	Defines and names a user-generated function		Gen		4.5	33
DEF INT/SNG/DBL/STR	Declares the variable type as integer, single-precision, double-precision or string		Gen		1.1	34
DEF USR	Specifies the start address of the assembly language subroutine called from memory by USR		Gen		2	34
DEL	Deletes a line or portion of a line in the program	Comm				26
DIM	Specifies the maximum values for array variables and assigns the area		Gen		18.3	34

Item	Description	Command	Statement	Function	Execution Time (ms)	Page
EDIT	Edits one line of the program	Comm				27
END	Terminates the execution of a program and closes all files		Gen			34
EOF	Verifies that the port buffer of the specified port is empty			Spec	2.8	61
ERL/ERR	Returns the error code and the line number where the error has occurred			Spec	1.7/3.2	61
ERROR	Simulates an error and allows error codes to be defined		Gen			35
FIX	Returns the integer part of a number			Arith	6.6	55
FOR...TO... STEP~NEXT	Repeats a For to NEXT loop a specified number of times		Gen		1.5	35
FRE	Returns the range of available memory			Spec	2.3	61
GOSUB~ RETURN	Calls and executes the subroutine and returns to the original program line with a "RETURN" statement		Gen		1.2/0.7	36
GOTO	Branches to a specified line number		Gen		0.9	37
HEX\$	Returns a string representing the hexadecimal value of the decimal argument			Char	4	57
IF...THEN...ELSE IF...GOTO ELSE	Selects the statement to be executed or branch destination as the result of an expression		Gen		5.5	37
INKEY\$	Returns a character read from the keyboard			Spec	2.1	61
INPUT	Reads key input and assigns it to the specified variable		Gen			37
INPUT\$	Returns a character string read from the keyboard and assigns it to the specified variable			Spec		61
INSTR	Searches for the first occurrence of a character string and returns its position			Char	3.8	57
INT	Shortens an expression to a whole number			Arith	9.1	56
KEY ON/OFF/STOP	Controls initiation, cancellation, and halting of key input interrupt		Gen			38
LEFT\$	Returns a character string of the specified number of characters, beginning at the left of the string			Char	3.4	57
LEN	Returns the total number of characters in a specified character string			Char	2.6	58
LET	Assigns the result of the expression to the variable		Gen		2	39
LINE INPUT	Reads one line of input from the keyboard and assigns it to a character string variable		Gen			39
LIST/LLIST	Displays or prints a program	Comm				27
LOAD	Loads the program from the EEPROM or from a port	Comm				28
LOC	Returns the number of characters in the input queue waiting to be read			Spec	2.7	62
LOG	Returns the natural logarithm			Arith	9.1	56
MID\$	Returns the specified number of characters starting from the specified character position			Char	3.9	39



Item	Description	Command	Statement	Function	Execution Time (ms)	Page
MON	Sets the terminal to monitor mode	Comm				28
MSET	Sets the address boundary for an assembly program	Comm			6.1	28
NEW	Clears the program and all currently defined variables	Comm				29
OCT\$	Returns a string which represents the octal value of the decimal argument			Char	4.6	58
ON COM GOSUB	Defines the branch destination of a subroutine invoked by an interrupt from a communication port		Gen			40
ON ERROR GOTO	Causes branching to the specified line in the event of an error		Gen		1.1	41
ON GOSUB ON GOTO	Causes branching to the specified line when "expression" is "true"		Gen		2.5	41
ON KEY GOTO ON KEY GOSUB	Causes branching to the specified line when the specified key is input		Gen		1.8/1.8	41,42
ON PC GOSUB	Defines an interrupt number and its associated subroutine branch line number		Gen		2.9	43
OPEN	Opens a port		Dev		3.4	52
PC GET	Reads data from the PC output area and assigns it to the specified variable		Gen		5.4/3.1	45
PC ON/STOP	Enables or stops an interrupt invoked by the PC		Gen			45
PC PUT	Writes the value of a numeric expression to the PC input data area		Gen		3	46
PC READ (@)	Reads data from the specified PC memory area, converts it to the specified format, and assigns it to the specified variables		Gen		9.8	46
PC WRITE (@)_	Converts data to the specified format and writes it to the specified PC memory area		Gen		9.7	47
PEEK	Reads the contents of a specified memory address			Spec	3.3	62
PGEN	Sets the program memory area to be used	Comm				29
PINF	Displays the program area currently being used	Comm				29
PNAME	Names, or deletes the name, of the program selected	Comm			1.5	30
POKE	Writes data to a specified memory address		Gen		2.7	47
PRINT/LPRINT	Displays or prints the value of an expression		Gen			47
PRINT USING LPRINT USING	Displays or prints a character string in the specified format		Gen			48
RANDOM	Reseeds the random number generator		Gen		4.8	49
READ	Reads values from a data statement and assigns them to variables		Gen		3.5	49
REM	Inserts a comment statement into the program		Gen		1.4	49
RENUM	Reassigns line numbers in the program	Comm				30

Item	Description	Command	Statement	Function	Execution Time (ms)	Page
RESTORE	Specifies which DATA statement will be used by the next READ statement		Gen		1	50
RESUME	Specifies the line where execution will resume after error processing		Gen		3.7	50
RIGHT\$	Returns the number of characters in a string starting from the right			Char	3.5	58
RND	Returns a random number between 0 and 1			Arith	4.2	56
RUN	Executes the program	Comm				30
SAVE	Saves the program to the EEPROM or to a device connected to a communication port	Comm				30
SGN	Returns the sign of an argument			Arith	2.6	56
SIN	Returns the sine of a number			Arith	15.9	56
SPACE\$	Returns an empty string of the specified number of characters			Char	2.4	59
STOP	Stops program execution		Gen			50
STR\$	Converts a numeric value into a character string			Char	3.3	59
STRING\$	Returns a character string of the specified length			Char	3.1	59
TAB	Outputs spaces up to the specified column position			Char		59
TAN	Returns the tangent of a number			Arith	31.9	56
TIME\$	Sets or gives the time			Spec	1.8/2.8	59
TRON/TROFF	Specifies or cancels a program trace	Comm				31

Item	Description	Command	Statement	Function	Execution Time (ms)	Page
USR	Calls an assembly language function routine defined by a DEF USR statement			Spec	2.6	63
VAL	Converts a character string into a numeric value			Char	3.2	60
VERIFY	Verifies the program and the EEPROM contents	Comm				31
VARPTR	Returns the memory address where the variable is stored			Spec	2.3	65
WAIT	Sets a delay before the next command is executed		Gen			50

## List of Program Examples

Example No.	Description	Page
6-1-1	Transfers data from the PC to the ASCII Unit using the PC Read statement	80
6-1-2	Writes data to the PC using the PC Write statement	88
6-1-3	Prints data at fixed time intervals using the LPRINT statement	82
6-1-4	Inputs data from the keyboard and transfers it to the PC using the INPUT statement	89
6-1-5	The PC controls execution of the ASCII Unit by interrupt	90
6-1-6	The PC directs execution of the ASCII Unit using the PC GET statement	90
6-1-7	ASCII Unit directs execution of the PC using the PC PUT statement	91
6-1-8	Prints PC data using the PC READ Statement	92
6-1-9	Accepts input data from a terminal and writes it to the PC using the PC WRITE Statement	92
6-1-10	Retrieves and prints PC data using the PC GET Statement	93
6-1-11	Uses PC interrupts to direct execution of the ASCII Unit	87
6-1-12	Prints PC data and the time of transfer	96
6-1-13	Displays the state of PC bit 1000	96
6-1-14	Inputs data from a bar code reader using the PC WRITE Statement	97
6-1-15	Reads data form an input file through a com port	97
6-1-16	Transfers data using the WAIT statement and the START/STOP switch	98
6-1-17	Directs processing through interrupts	99
6-2-1	Transfers data from PC to ASCII Unit with the PC maintaining control	94
6-2-2	Transfers data from ASCII Unit to PC with the ASCII Unit maintaining control	95
6-2-3	Transfers data from PC to ASCII Unit with the PC maintaining control	97
6-2-4	Transfers data from ASCII Unit to PC with the PC maintaining control	99
6-2-5	Process data with the ASCII Unit	101
6-2-6	Process data with the PC	102
6-3-1	Assembly-language program application	102



# Appendix H

## Programming with Windows 95

### HyperTerminal

## Overview

Previously, an FIT10 Terminal Pack or N88-DISK-BASIC was required to program the ASCII Unit. Now, however, it is possible to program using HyperTerminal and other accessories that have been added to the standard Windows 95 package.

When creating programs using HyperTerminal, the backspace and cursor keys cannot be used in operations on the terminal screen.

## Setup

### Connections

Provide a connecting cable for connecting the ASCII Unit to the computer. Connector specifications and the connection configuration are shown below.

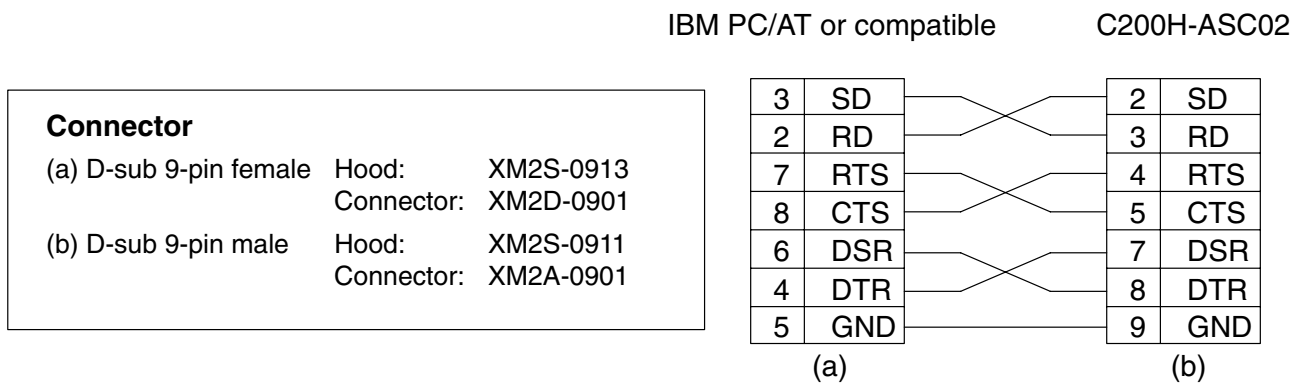

### DIP Switch Settings

Set the baud rate for port 1 to 9,600 bps using pins 1 to 3 on the DIP switch on the right side of the back panel of the ASCII Unit.

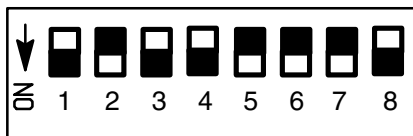

## HyperTerminal Startup

- Start up HyperTerminal via **Start/Programs/Accessories**.
- After starting up HyperTerminal, make the settings shown below.

### Location Information

Area code: Enter the area code and select **OK**.

### HyperTerminal

A message prompting you to install a modem will be displayed. Select **No**.

### Connection Description

Name: Enter the desired name and select **OK**.

### Connect To

Connect using: Select **COM1** and **OK**.

### COM1 Properties

Bits per second: Set to 9,600.

Data bits: Set to 8.

Parity: Set to "None".

Stop bits: Set to 2.

Flow control: Set to "None".

Select **OK**.

### Line Delay

In **File/Properties/Settings/ASCII Setup...**, set the **Line delay** to 300.

Select **OK**.



- Default settings can be used for all the other settings.
- These settings do not have to be repeated each time you use HyperTerminal. Simply select the icon with the required name.
- If the modem settings have already been made for the computer you are using, only the settings from *Connection Description* onwards are required.

## Confirming Connection

Key in Ctrl + X at the computer. The following message will be displayed indicating that connection is complete.

**C200H-ASC02 (CF-BASIC) V1.6 1994. 12. 28**  
**(C) Copyright OMRON Corporation 1990**  
**READY**

## Operation

### Creating Programs

Programs are created using text editors, such as Notepad, and are saved as text.

### Transferring Programs from the Computer

- 1, 2, 3... 1. Delete the program currently in the ASCII Unit memory using the **NEW** command.
2. Transfer the program saved by selecting **Send Text File...** from the **Transfer** menu as shown below.

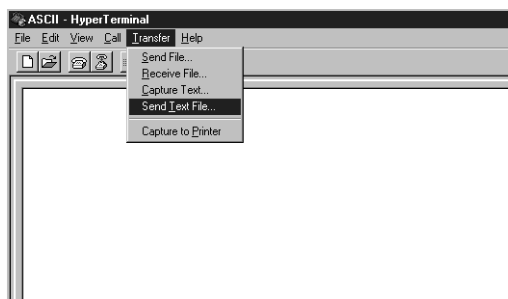

### Transferring Programs to the Computer

- 1, 2, 3... 1. Input the following.

SAVE #1, "COMU: (43)" ↵

- 1, 2, 3... 1. Select **Capture Text** from the **Transfer** menu, and specify the name of the file for saving.
2. Start program transfer using the START/STOP switch on the front panel of the ASCII Unit.
3. When program transfer has finished, select **Stop** in **Transfer/Capture Text**, and key in Ctrl + X.

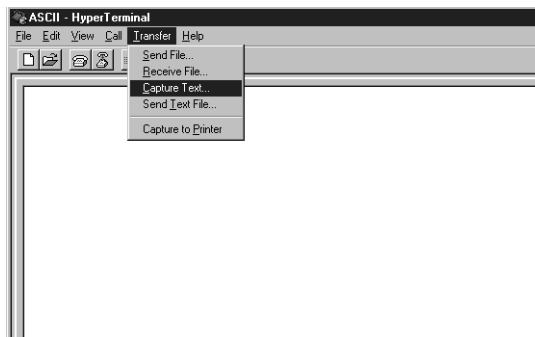





# Appendix I

## Assembly Language Programming with a Terminal

Details on assembly language programming for ASCII Units using a Windows terminal are given below. For details on setting up ASCII Units and programming in BASIC, refer to *Appendix H Programming with Windows 95 HyperTerminal*.

### 1. Setup

- 1, 2, 3... 1. Provide cables and make the settings required for connection to a terminal. If necessary, refer to the relevant sections in this or other manuals.
2. Reserve an assembly language programming area in the memory area (&H2000 to &H7FFF) using the MSET command as shown below.

```
READY
MSET &H3000 ↵      ..... Reserves &H2000 to &H3000 as assembly language area.
READY
```

**Note:** For details on actual assembly language programming, refer to the HD6303X user's manual (Hitachi).

### 2. Creating Programs

The ASCII Unit has an in-built mini-assembler. The procedure for inputting programs using the mini-assembler is given here.

First, go into mini-assembler mode.

```
READY
MON ↵              ..... Goes into monitor mode.
C200H-ASC02 MONITOR V1.6
*                  ..... Prompt for monitor mode.
* [Ctrl+A]         ..... Goes into mini-assembler mode.
!                  ..... Prompt for mini-assembler mode.
```

Next, input the program.

```
! 2000: LDAA #$80
2000- 86 80      LDAA #$80
! LDAB #$7F
2002- C6 7F      LDAB #$7F
! STD $4000
2004- FD 40 00   STD  $4000
! X ↵           ..... Exits mini-assembler mode ("X" is upper case).
*
```

Format:           !(address):(mnemonic)           ..... When address is input  
                  !(mnemonic)                   ..... When address is omitted.  
                   └─ Insert space

### 3. Transferring Assembly Language Programs to the Terminal

- 1, 2, 3... 1. Input the following in monitor mode.

```
*S2000.2100                                   ..... &H2000 to &H2100 saved.
```

Format:           S(start address).(end address)

2. Select **Capture Text** from the **Transfer** menu, and specify the name of the file for saving.
3. Start program transfer using the START/STOP switch on the front panel of the ASCII Unit.
4. When program transfer has finished, select **Stop** in **Transfer/Capture Text**, and key in Ctrl + X.

### 4. Returning to BASIC

Key in Ctrl + B to leave monitor mode and return to BASIC mode.

```
* [Ctrl+B]
READY
```

### 5. Transferring Assembly Language Programs from the Terminal

Use the following procedure to transfer the program saved in procedure 3 above back to the ASCII Unit.

- 1, 2, 3... 1. Input the following in monitor mode.

```
*L ↵
```

- 2. Start program transfer using the START/STOP switch on the front panel of the ASCII Unit.
- 3. Transfer the programs saved by selecting **Send Text File...** from the **Transfer** menu.

The operations required to go between BASIC mode, monitor mode, and mini-assembler mode are summarized in the diagram below.

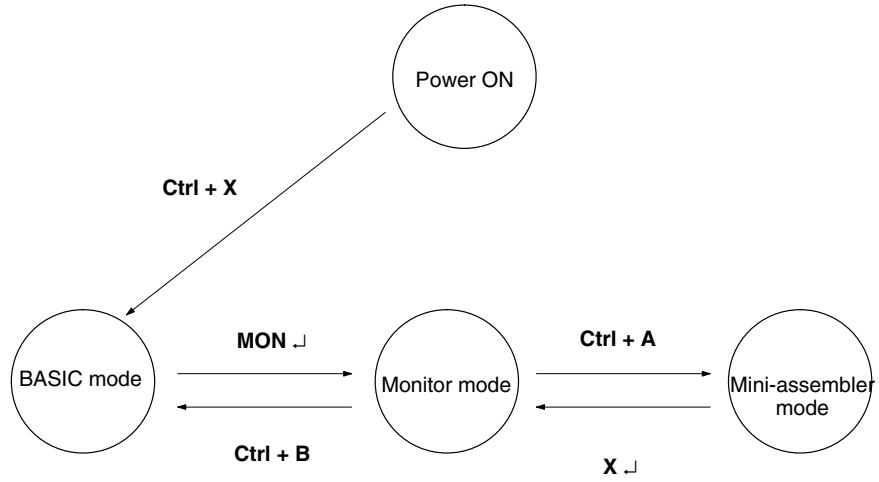



# Glossary

<b>Accumulator Register</b>	The arithmetic hardware register of the microprocessor.
<b>ASCII Unit Program</b>	The BASIC program that runs the ASCII Unit and communicates with the PC program.
<b>Backplane</b>	A rack of hardware slots sharing a common bus line to which the CPU and all of its I/O Units are connected.
<b>base address</b>	The first address of a block of memory or data. When a block of data is to be transferred with one of the I/O commands, the base address must be specified.
<b>baud rate</b>	The speed at which data is transferred during I/O operations. The baud rate for the two ports is set with the right-side DIP switch. The standard baud rates are 300, 1200, 2400, 4800, 9600, and 19,200.
<b>binary</b>	The number system that all computers are based on. A binary digit can have only two values, zero and one. The octal and hexadecimal number systems are based on binary digits.
<b>bit</b>	The smallest piece of information that can be represented on a computer. A bit has the value of either zero or one. A bit is one binary digit.
<b>boot program</b>	The BASIC program that is automatically loaded into the ASCII Unit RAM upon power up or reset.
<b>byte</b>	A group of eight bits that is regarded as one unit.
<b>communication port</b>	A connector through which external peripheral devices can communicate with a host computer or microprocessor. The ASCII Unit has two communication ports used to connect to a personal computer, printer, or other I/O devices.
<b>data section</b>	A special PC memory area that is assigned to each individual ASCII Unit. The ASCII Unit uses the data section for reading and writing data to the PC as well as for communicating status information.
<b>data transfer routine</b>	The PC requires a dedicated data transfer routine incorporated into its program in order to communicate with the ASCII Unit. A data transfer routine is not necessary when the memory area designator parameter is used with the PC READ and PC WRITE statements.
<b>data word</b>	PC data is organized into units called words. Each word contains 16 bits and has a unique address in the PC memory. When transferring a block of data between the PC and the ASCII Unit, it is necessary to specify the address of the first data word in the block as well as the number of data words to be transferred. Throughout this manual the terms word and data word are used interchangeably.
<b>device control codes</b>	Keyboard strokes entered with the control key depressed that send control messages to peripheral devices such as a terminal display or a printer. For

example, control codes can be used to position the cursor on a display or to cause the printer to print a line of text as it is being typed.

<b>DIP switches</b>	There are two sets of DIP switches on the back panel of the ASCII Unit. Each DIP switch has eight pins which can be set to either zero or one. These DIP switches are used for setting hardware parameters such as the baud rate and the start up mode.
<b>EPROM/EEPROM</b>	Nonvolatile memory (retains data when power is disconnected) is used for permanent storage of up to three ASCII Unit programs. If the start mode is set to automatic, the boot program will be loaded to the RAM from the EPROM upon power up or reset. Programs can be read from and written to the EPROM with the LOAD and SAVE commands, respectively.
<b>execution sequence</b>	The order of operation in which the PC and ASCII Unit hardware execute their respective programs.
<b>flag</b>	A hardware flag is a bit that is set or cleared by the machine to indicate a particular state or condition of the Unit to a peripheral device or to the program. Examples of PC hardware flags are the Read and Write flags. A software flag is set or cleared by the user to indicate to the hardware a particular choice or option. For instance, software flags are sometimes used for setting the direction of data transfer or the baud rate of a communication device.
<b>hexadecimal</b>	Hexadecimal or hex is a numerical system based on the number 16. One hex digit can be represented by four binary digits in the range of zero to 15. The numbers 10 through 15 are represented by the letters A through F, respectively.
<b>Index register</b>	One of the microprocessor's hardware registers. It is used for assembly language programming.
<b>interrupt number</b>	A code that is sent from the interrupting device to the microprocessor indicating which device is "calling." The interrupt number is especially important if there is more than one peripheral device connected to a microprocessor.
<b>interrupt</b>	A signal sent to the microprocessor from a peripheral device that causes the microprocessor to alter its normal processing routine. An interrupt says to the microprocessor, "stop what you're doing and pay attention to me !" When an interrupt is acknowledged by the microprocessor, program execution will branch to an interrupt service routine specifically written to handle the given interrupt.
<b>I/O device</b>	I/O stands for input/output. Some examples of I/O devices are printers, modems, fax machines, and display terminals.
<b>Machine No. switch</b>	Used to select the unit number for the assignment of a data section. The Machine No. switch is located on the front panel of the ASCII Unit.
<b>mantissa</b>	The part of a numerical expression to the right of the decimal point.
<b>memory area designator (@)</b>	A parameter of the PC READ and PC WRITE statements used to access specific PC data areas. When using the memory area designator for data transfer, the ASCII Unit does not need an accompanying PC data transfer routine.

<b>monitor mode</b>	The mode or environment where assembly language programs are written, edited, and tested.
<b>monitor mode commands</b>	The commands used in monitor mode for writing, editing, and debugging an assembly language program.
<b>MSB/LSB</b>	MSB stands for Most Significant Byte and refers to the upper or left half of a data word ( a data word contains two bytes ). The Least Significant Byte refers to the lower or right half of a data word.
<b>octal</b>	A numerical system based on the number eight. One octal digit is made up of three binary digits in the range of zero to seven.
<b>parameter/argument</b>	A parameter is a value or symbol supplied to a BASIC or assembly language command. A parameter either directs a command to implement a particular option or format, or supplies a memory address where data can be stored. Similar to a parameter and sometimes used interchangeably is the term "argument". Where a parameter usually supplies some type of control information to the function or command, an argument is usually a variable that supplies needed data.
<b>PC Program</b>	A program that runs the PC; it is written in the Ladder Diagram programming language.
<b>polling</b>	A process whereby the microprocessor periodically checks the value of a specified bit or byte, and depending on that value, the microprocessor takes some specified action.
<b>port buffer</b>	Special memory that is used to temporarily store data that has just been received or is about to be sent out through a communication port.
<b>program counter</b>	A microprocessor register that keeps track of program execution. It is used for assembly language programming.
<b>RAM</b>	Stands for Random Access Memory and is used for running the ASCII Unit program. RAM will not retain data when power is disconnected. Therefore data should not be stored in RAM.
<b>Read Flag</b>	A PC hardware flag that indicates when data can be read from the PC. When this flag is set, data can be accessed by a peripheral device.
<b>reading/writing</b>	When something is read, it is taken or copied from a remote location and brought to the reference point. When something is written, it is sent from the reference point to a remote or peripheral device.
<b>RS-232C Interface</b>	The industry standard connector for serial communications. The ASCII Unit communication ports use RS-232C connectors.
<b>scan time and refreshing</b>	The PC is constantly scanning through its program, checking all of its inputs and adjusting its outputs. The time required for the PC to run through its program one time is called the scan time. Each time the PC scans its program, it updates or refreshes its outputs. The ASCII Unit cannot read data from the PC during data refresh.
<b>set/clear</b>	Set means to give something the value of one. Clear means to give something the value of zero. When a flag is set, it becomes one; when a flag is cleared, it becomes zero.

<b>stack pointer</b>	A microprocessor index register used for assembly language programming.
<b>start address</b>	The starting address of a block of data. This term is used as a parameter in many of the assembly language monitor mode commands.
<b>start mode</b>	Indicates how the ASCII Unit starts up when power is first applied or the Unit is reset. The two choices are manual mode and automatic mode. The mode can be selected by setting pins one and two of the left-side DIP switch.
<b>START/STOP switch</b>	A toggle switch on the front panel of the ASCII Unit used for starting and stopping execution of the ASCII Unit program.
<b>upload/download</b>	Upload usually refers to the transfer of a program or information from a remote device to a computer or other controlling device. Download usually refers to data transfer from a computer or other controlling device to a remote device. From the users point of view, if data is being sent to another device, it is being downloaded. If data is being received from another device, it is being uploaded.
<b>valid signal line</b>	A parameter of the OPEN command which specifies which communication signals (CTS, DSR, RTS) are to be used for handshaking.
<b>watchdog timer</b>	A clock on the PC that measures the time it takes the PC program to complete one scan. If the scan time is longer than 100 ms, a warning is issued. If the scan time is longer than 130 ms, the PC will suspend operation. The watchdog timer is reset at the beginning of each scan.
<b>word</b>	A word is made up of two bytes or 16 bits. The term "word" is used interchangeably with the term "data word" to indicate a single unit of data. Blocks of data are transferred in "word" units. For data transfer, the address of a data block's first "word" and the number of "words" to be transferred must be specified.
<b>Write Flag</b>	A PC hardware flag that indicates when data can be written to the PC. When this flag is set, data can be written to the PC.
<b>XON/XOFF</b>	OPEN statement parameters that control the rate at which the port buffers receive and transmit data. If the XON command is specified to be ON by the OPEN statement, then when the port buffer becomes 3/4 full, the ASCII Unit will suspend data transfer until the port buffer is less than 1/4 full. In a case where a transmitting device is sending data at a faster baud rate than the ASCII Unit is set for, the XON command will keep the transmitted data from being written over.



# Index

## A

applications, precautions, xiii

ASCII Busy Flag, 13

ASCII Unit

boot program, 4

start mode, 4

Assembly language

Accumulator, 68

base address, 69

DEF USR statement, 68

format, 69

Index register, 68

LOAD command, 68

monitor commands

Compare, 72

Disassembler, 74

Dump, 70, 73

Go, 75

Hexadecimal math, 77

Load, 75

Mini-assembler, 76

Move, 71

New, 73

Register, 72

Save, 74

Step, 76

Verify, 75

monitor mode, 69

MSET command, 68

program counter, 69

RAM, 68

S and L commands, 68

SAVE command, 68

stack pointer, 68

start address, 69

terminology, 69

USR function, 68

VARPTR function, 68

assembly language, 18

S and L commands, 18

## B

backplane, 4, 7

base address, 16

base word, 13

BASIC

arrays, 22

character set, 20

commands, 20, 26

configuration, 20

constants, 20

data types, 21

expressions, 23

format, 25

functions, 20

operator priority, 24

operators, 23

statements, 20

general, 32

type conversion, 22

variables, 21

BASIC program

execution, 18

storage, 17

transfer, 17

battery life, 109

baud rate, 109

baud rate setting

Port 1, 6

Port 2, 6

booted, 4

## C-D

communication flags, 137

communication mode, 109

communication parameters, 52

control codes, 114

current rating, 109

data format conversion, 129

data formats, 125

A format, 127

B format, 126

H format, 126

I format, 125

O format, 126

S format, 127

data section, 11

bit definitions, 12

data transfer

direction, 18

LOAD command, 17

PC GET, 79

PC PUT, 79

PC READ, 79

PC WRITE, 79

programs, 79

SAVE command, 17

device control codes, 114

DIP switch settings

- baud rate, 6
- boot mode, 5
- data section mode, 5
- screen size, 5
- start mode, 5

DIP Switches, 4

DIP switches

- left side, 5, 110
- left-side, 4
- right side, 6, 111

## **E–I**

EEPROM, 5

hardware specifications, 109

indicator LEDs, 3

indicators, 2

inspection items, 143

installation, precautions, xiii

interface signal timing, 112

interrupt

- assembly program, 69
- interrupt number, 12

## **M–P**

maintenance, 143

memory

- capacity, 109
- memory area designator, 16

memory config

- bits, 10
- flags, 10
- words, 10

operating environment, precautions, xii

panels

- back panel, 4, 110
- front panel, 3

PC cycle time, 117

PC DM Area, 13

PC program, 16

PC statement execution times, 133

peripheral device, address assignments

- PTM HD63B40, 138
- Real-Time clock, 138
- Work Area, 139

peripheral devices

- connection to personal computer, 112
- connection to plasma display, 112
- connection to printer, 112

personal computer, communication settings, 17

physical dimensions, 109, 114

port address assignments, 136

port error flags, 13

ports, 2

precautions, xi

- applications, xiii
- general, xii
- operating environment, xii
- safety, xii

program, program transfer, 17

programs

- ASCII program, 16
- PC program, 16

## **R**

RAM, 5

Read Flag, 12

refresh timing

- BASIC statements, 117–123
- ON PC GOSUB statement, 120
- PC GET statement, 117
- PC OFF statement, 123
- PC ON statement, 121
- PC PUT statement, 118
- PC READ statement, 118
- PC READ@... statement, 119
- PC STOP statement, 122
- PC WRITE @... statement, 120
- PC WRITE statement, 119

RS–232 interface, 2, 111

## **S–X**

safety precautions. *See* precautions

stack pointer, 68

switches, 2

- Machine Number, 2
- START/STOP, 2

system configuration, 7

Terms, 2

transfer capacity, 109

transmission mode, 109

transmission signal timing, 113

Write Flag, 12

XON, 17

## Revision History

A manual revision code appears as a suffix to the catalog number on the front cover of the manual.

Cat. No. W165-E1-04



The following table outlines the changes made to the manual during each revision. Page numbers refer to the previous version.

Revision code	Date	Revised content
1	February 1989	Original production
2	July 1990	Revision of text
2A	July 1991	Reformat. <b>Page 27:</b> CTRL + C changed to CTRL + X in <i>Remarks</i> for AUTO command, and CTRL + Break changed to CTRL + X in <i>Purpose</i> for CONT command. <b>Page 35:</b> SQR(X**2 + Y**2 + Z**2) changed to SQR(X^2 + Y^2 + Z ^2) in <i>Example</i> for DEF FN statement. <b>Page 40:</b> End of first sentence at top of page changed to “by commas or colons.” <b>Page 48:</b> Reference to PC READ instruction changed to appendix C for PC WRITE parameter definitions. <b>Page 49:</b> “INF function” corrected to “INT function” in second sentence. <b>Page 129:</b> Table at top of page revised, and table of memory area designates added for PC READ and PC WRITE. <b>Page 132:</b> Definition of “n” corrected for S Format. <b>Page 136:</b> Four numbers at top right of page corrected. <b>Appendix F:</b> Execution times added.
2B	November 1992	<b>Page 21:</b> Paragraph on syntax errors added to <i>Variable Name</i> . <b>Page 92:</b> <i>Example 18</i> has been added to <i>Example Programs</i> .
2C	December 1994	<b>Page 6:</b> The pin numbers for port 2 corrected in the diagram.
3	February 2000	<i>Precautions</i> section, <i>Appendix H</i> and <i>Appendix I</i> added. In addition, the following changes were made. <b>Page 7:</b> Changes made to mounting information. <b>Page 11:</b> Changes made to model numbers in diagram. <b>Page 44:</b> Information added to “ON PC GOSUB Statement.” <b>Page 61:</b> Information added to “PEEK Function.” <b>Page 109:</b> Note added to table. <b>Page 113:</b> Notes added under diagram. <b>Page 133:</b> Introduction added and changes made to first table.
04	September 2002	<b>Page 41:</b> Notes on interrupt routines added to <i>Program Remarks</i> . <b>Page 53:</b> Information on RTS ON/OFF specifications added to <i>Remarks</i> .







## OMRON ELECTRONICS LLC

1 Commerce Drive  
Schaumburg, IL 60173  
847.843.7900  
For US technical support or  
other inquiries: 800.556.6766

## OMRON CANADA, INC.

885 Milner Avenue  
Toronto, Ontario M1B 5V8  
416.286.6465

## OMRON ON-LINE

Global - <http://www.omron.com>  
USA - <http://www.omron.com/oei>  
Canada - <http://www.omron.ca>

### UNITED STATES

To locate a Regional Sales Office, local Distributor or  
to obtain product information, call: 847.843.7900

### CANADA REGIONAL SALES OFFICES

<b>Ontario</b>	Toronto	416.286.6465
	Kitchener	519.896.1144
	Kingston	613.376.3968
<b>Quebec</b>	Montreal	514.636.6676
<b>British Columbia</b>	Vancouver	604.522.8855
<b>Alberta</b>	Edmonton	403.440.0818
	Calgary	403.257.3095

### BRAZIL SALES OFFICE

**Sao Paulo** 55.11.5564.6488

### ARGENTINA SALES OFFICE

**Cono Sur** 54.114.787.1129

### MEXICO SALES OFFICES

**Florida** 954.227.2121      **Ciudad Juarez** 656.623.7083  
**Mexico, D.F.** 555.534.1195      **Monterrey, N.L.** 818.377.4281

Компания «Life Electronics» занимается поставками электронных компонентов импортного и отечественного производства от производителей и со складов крупных дистрибьюторов Европы, Америки и Азии.

С конца 2013 года компания активно расширяет линейку поставок компонентов по направлению коаксиальный кабель, кварцевые генераторы и конденсаторы (керамические, пленочные, электролитические), за счёт заключения дистрибьюторских договоров

Мы предлагаем:

- Конкурентоспособные цены и скидки постоянным клиентам.
- Специальные условия для постоянных клиентов.
- Подбор аналогов.
- Поставку компонентов в любых объемах, удовлетворяющих вашим потребностям.
- Приемлемые сроки поставки, возможна ускоренная поставка.
- Доставку товара в любую точку России и стран СНГ.
- Комплексную поставку.
- Работу по проектам и поставку образцов.
- Формирование склада под заказчика.
- Сертификаты соответствия на поставляемую продукцию (по желанию клиента).
- Тестирование поставляемой продукции.
- Поставку компонентов, требующих военную и космическую приемку.
- Входной контроль качества.
- Наличие сертификата ISO.

В составе нашей компании организован Конструкторский отдел, призванный помогать разработчикам, и инженерам.

Конструкторский отдел помогает осуществить:

- Регистрацию проекта у производителя компонентов.
- Техническую поддержку проекта.
- Защиту от снятия компонента с производства.
- Оценку стоимости проекта по компонентам.
- Изготовление тестовой платы монтаж и пусконаладочные работы.



Тел: +7 (812) 336 43 04 (многоканальный)

Email: [org@lifeelectronics.ru](mailto:org@lifeelectronics.ru)